



Model STVA

2.50" to 6.00" Manual Balancing Valve

- Accurate and precise flow measurement
- Accurate and precise flow balancing
- Positive Shut-off
- "Y" Pattern Globe style design
- Multi-turn, 360° handwheel with vernier scale and digital readout
- Built in memory stop
- Offsetting Pressure/temperature ports, Self sealing with optional Drain Kits
- Wide variety of accessories available



STVA

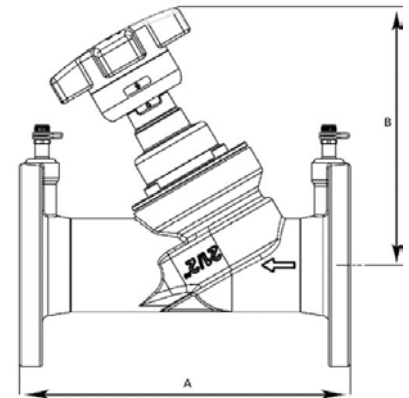

SPECIFICATIONS	
Pressure Ratings:	235 psi / 16 bar (PN 16)
Temperature Ratings:	14°F to 248°F (-10°C to 120°C)
Body:	Cast Iron
End Connections:	ANSI 125# Flanged
Gaskets:	EPDM
Seat Seal	PTFE
Handwheel:	Polyamide Plastic

NOMINAL DIMENSIONS & WEIGHTS									Valve Selection Guide			
MODEL	SIZE			A Length	B Height	WEIGHT		Handwheel Turns		Minimum Flow	Nominal Range of Flow	Maximum Flow
	in	mm				lbs	kg					
STVA-250	2.5"	65	in	11.42	8.94	30.9	14	10	GPM	2.13	33 - 100	318.3
			mm	290	226				LPM	8.07	125 - 378	1205
STVA-300	3.0"	80	in	12.2	9.5	44.1	20	10	GPM	4.19	100 - 117	374.5
			mm	310	241				LPM	15.9	378 - 442	1418
STVA-400	4.0"	100	in	13.78	10.2	57.3	26	10	GPM	6.09	117 - 200	646.8
			mm	350	259				LPM	23.0	442 - 756	2448
STVA-500	5.0"	125	in	15.75	11.73	88.2	40	10	GPM	7.61	200 - 320	1025
			mm	400	298				LPM	28.8	756 - 1210	3879
STVA-600	6.0"	150	in	18.9	12.05	110.2	50	10	GPM	13.7	320 - 440	1447
			mm	480	306				LPM	51.9	1210 - 1663	5477

FLOW CALCULATIONS
The Minimum Flow is calculated from the minimum recommended pressure drop, 1 ft WG (=3.0 kPa)
The Nominal Flow is calculated from the maximum setting of the valve and the minimum recommended pressure drop, 2 ft WG (=6.0 kPa)
The Maximum Flow is calculated from the maximum setting of the valve and the maximum pressure drop, 20 ft WG (=60.0 kPa)

Optional features and accessories available for this product are an extra charge, and not included in the standard model price.

Pressure Drop Tables: Model STVA 2.50" to 6.00"

Series STVA 2.50" - 6.00"

This diagram details the relationship between flow, pressure drop and valve preset points. Use the diagram to select the correct valve size and corresponding handwheel setting to fulfill the application requirements.

Determine the required flow in the circuit (A) and the pressure drop (B). Draw a line between these two values. Read off the corresponding Cv value on the Cv scale.

Determine the valve setting, in handwheel turns, by drawing a horizontal line (D) from the intersection point on the Cv scale to the corresponding valve setting position.

For the highest level of accuracy, it is recommended to choose a valve that has at least 3 open turns.

Example: A 4" valve is required to be open 7.5 turns for a Cv value of 160 at a flow rate of 150 gpm and a pressure drop of 2ft.

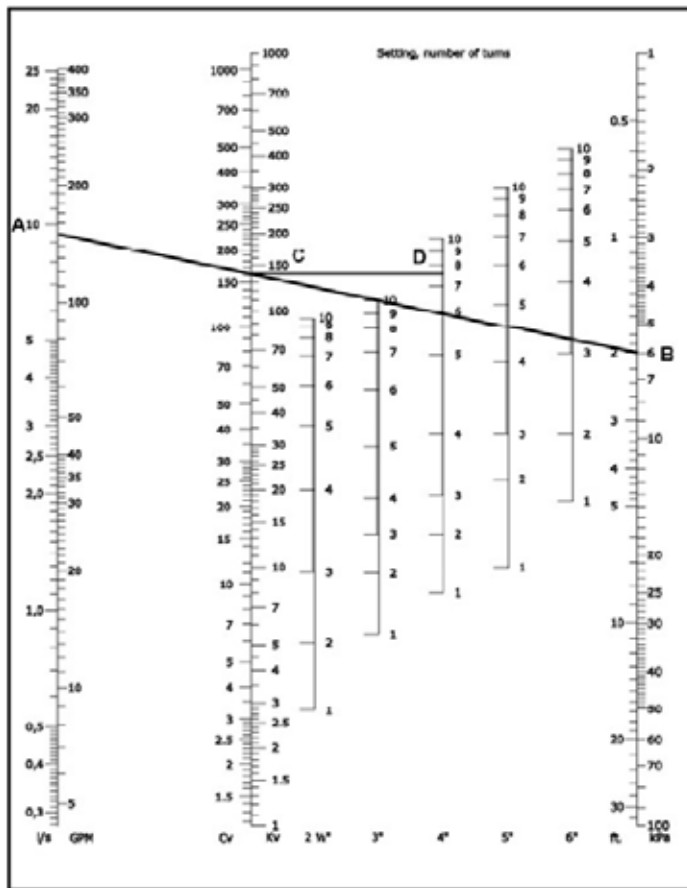

Cv Values for Valve Series STVA

Flow coefficient values (CV's) at various handwheel settings	Handwheel Setting				
	2-1/2"	3"	4"	5"	6"
	DN 65	DN 80	DN 100	DN 125	DN 150
1	3.20	6.40	9.30	11.60	20.90
1.5	4.60	8.70	12.80	19.70	29.00
2	5.90	11.00	15.70	25.50	38.30
2.5	8.50	13.30	19.10	30.20	53.40
3	11.10	15.70	22.00	38.30	78.90
3.2	13.10	16.60	23.80	42.90	90.50
3.4	15.10	17.50	25.50	48.70	103
3.6	17.40	18.60	29.00	55.70	118
3.8	20.30	19.70	33.60	63.80	135
4	23.20	21.50	38.30	73.10	151
4.2	26.80	23.20	45.20	82.40	164
4.4	30.40	24.90	53.40	91.60	176
4.6	34.00	27.30	61.50	102	189
4.8	37.60	30.70	69.60	113	202
5	41.20	34.20	77.70	123	216
5.2	44.80	38.30	85.80	135	231
5.4	48.40	42.90	94.00	146	246
5.6	52.00	47.60	102	157	260
5.8	55.60	52.20	109	166	273
6	59.20	56.80	115	174	285
6.2	62.80	61.50	122	183	298
6.4	66.10	66.10	129	194	311
6.6	69.60	70.80	135	204	322
6.8	73.10	75.40	140	215	332
7	76.60	79.50	145	225	341
7.2	80.00	83.50	151	235	351
7.4	82.90	87.60	157	246	363
7.6	85.80	91.60	162	255	374
7.8	88.70	95.10	168	264	384
8	91.10	98.60	174	274	394
8.2	93.40	102	180	283	406
8.4	95.70	105	186	292	418
8.6	97.40	108	190	302	428
8.8	99.20	111	194	310	437
9	101	114	197	317	447
9.2	103	116	202	324	456
9.4	104	119	206	331	465
9.6	106	123	211	338	474
9.8	107	125	216	343	484
10	108*	128*	220*	349*	493*

* Valve is fully open

Installation Recommendations

Install the valve in the correct flow direction according to the arrow on the valve body and the distance parameters detailed in Figure 1 (Note: D = pipe diameter).

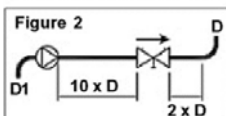
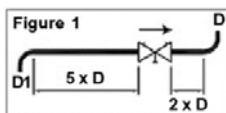

For Series STVA, cover the valve body with a wet cloth when soldering to prevent premature deterioration of valve components.

When used with a pump, it is recommended to use a straight length of pipe totaling 10 x D (instead of 5 x D) upstream or downstream to avoid turbulence that will affect the measuring accuracy. See Figure 2.

Turbulence can influence the measurements by up to 20% if this recommendation is not followed.

Flow Measurement & Accuracy

The measuring instrument connects to the test ports of the valve and is pre-programmed with Manual Balancing characteristics. The pressure drop and flow readings can be read off the display. If access to a Manual Balancing instrument is unavailable, other industry models are compatible. In addition, the flow can be determined using the pressure drop diagram that is included in the operating instructions with each Manual Balancing valve.

The accuracy is highest when the valve is fully open. Therefore, it is recommended to choose a valve that can be opened at least three turns at the calculated pre-setting value. Figure 3 represents the flow measurement deviation in relation to handwheel turns.

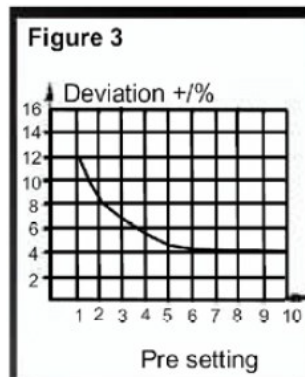

Figure 4

$$\text{Actual Flow} = \frac{QCBI}{\sqrt{\gamma}}$$

Figure 5

$$C_v = 1.52 \frac{q}{\sqrt{\Delta p}}$$

q in GPM, Δp in Ft. of H2O

$$C_v = \frac{q}{\sqrt{\Delta p}}$$

q in GPM, √p in PSI

Correction for Liquids

Applies to liquids other than water. Correct the measured flow (q) by the density (γ) according to this formula. See Figure 4

Sizing a Balancing Valve

When the differential pressure and design flow are known, use this formula to calculate Cv value. See Figure 5