



Multi-Function

MFV



www.flofab.com

001-cat-2016-mfv

Go to www.flofab.com in Our Products Section to see the Master Spec - <http://www.arcomnet.com/masterspec/>

TABLE OF CONTENTS

MFV- PRODUCT SPECIFICATIONS.....	2-3
MFV - TRIPLE DUTY VALVES.....	4-7
FEATURES.....	8
PERFORMANCE CURVES.....	9-20
TYPICAL PIPING DETAILS.....	21

HISTORY

Flo Fab was established in 1981 by Denis Gauvreau who created and developed the products line and constantly being perfected by Marc Gauvreau, as well as by a team of professional engineers and designers. It's a combination of existing designs from several renowned products and the innovative ideas of a new generation professionals.

Through the years, Flo Fab has acquired several companies and service entities including : AQUA-PROFAB (ASME Tanks manufacturer), MÉNARD, LÉONARD ÉLECTRIQUE, PMA. , Furthermore Flo Fab purchased equipment, fabrication designs and patterns from IDEALCO, a manufacturer of shell and tube type heat exchangers.

The after sales services, sales, engineering, R&D, production, quality control, accounting and administration departments of all the above companies share the same location.

In December 2014, Marc Gauvreau, son of the founder, acquired all shares of The company. Flo Fab and is constantly investing in new state of the art innovations new product like the XRI series and Prefab Skid for Hydronic Heating & cooling system, pumping systems. This has allowed Flo Fab to retain competent and experienced staff of professionals with varied and specialized abilities that constantly work on improving our existing products and add new engineered solutions that exceeding customer's expectations .

Flo Fab has grown quite rapidly and now proudly offers of a wide range of products available directly from one manufacturer. This includes pumps & pump packages, tanks, heat exchangers & hydronic accessories. This allows each project stakeholders to enjoy economical savings, peace of mind, best value for their investment and optimized total cost of ownership.



Product Specifications

Calibrated Balancing Valve - Shut Off Valve - Non Slam Check

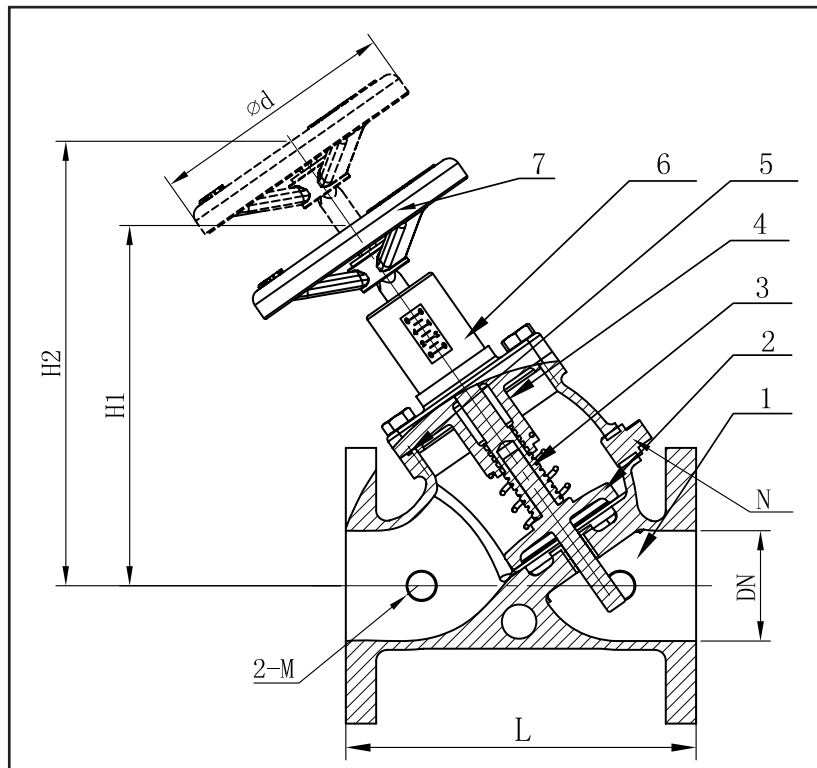

No.	Name	Material
1	Body	CI
2	Disc	DI+EPDM
3	Stem	SS410
4	Cover	CI
5	Gasket	EPDM
6	Scale Plate	Plastic
7	Handwheel	Carbon Steel

Technical

Pressure:
Class125

Working Temp:
-20°C -120°C
-4°F -248°F

Flange to:
ANSI B16.1

Dimensions (mm/in)									
✓									
MFV	0200-150F	0250-150F	0300-150F	0400-150F	0500-150F	0600-150F	0800-150F	1000-150F	1200-150F
NPS	2	2 1/2	3	4	5	6	8	10	12
DN	50 1.97	65 2.56	80 3.15	100 3.94	125 4.92	150 5.90	200 7.88	250 9.84	300 11.81
L	213 8.39	250 9.84	254 10	368 14.49	407 16.02	457 17.99	546 21.50	648 25.51	762 30.00
H1	226 8.90	240 9.45	257 10.12	295 11.61	330 12.99	352 13.85	530 20.87	584 22.99	609 23.98
H2	251 9.88	265 10.43	282 11.10	320 12.60	363 14.29	380 14.96	579 22.80	663 26.10	711 27.99
ød	180 7.09		250 9.84			350 13.78		450 17.72	
M	6.35 - 1/4" NPT								

MODELS	MFV1400-150F	MFV1600-150F	MFV1800-150F
✓			
Sizes	14" 350 mm	16" 400 mm	18" 450 mm
DIM "L"	35"	26 3/4"	28 3/8"
DIM "H"	41"	41"	41"

*All dimensions are NOT certified.
*Do not use for construction.
*Design, dimensions and material are subject to change without notice.

● Products Specifications

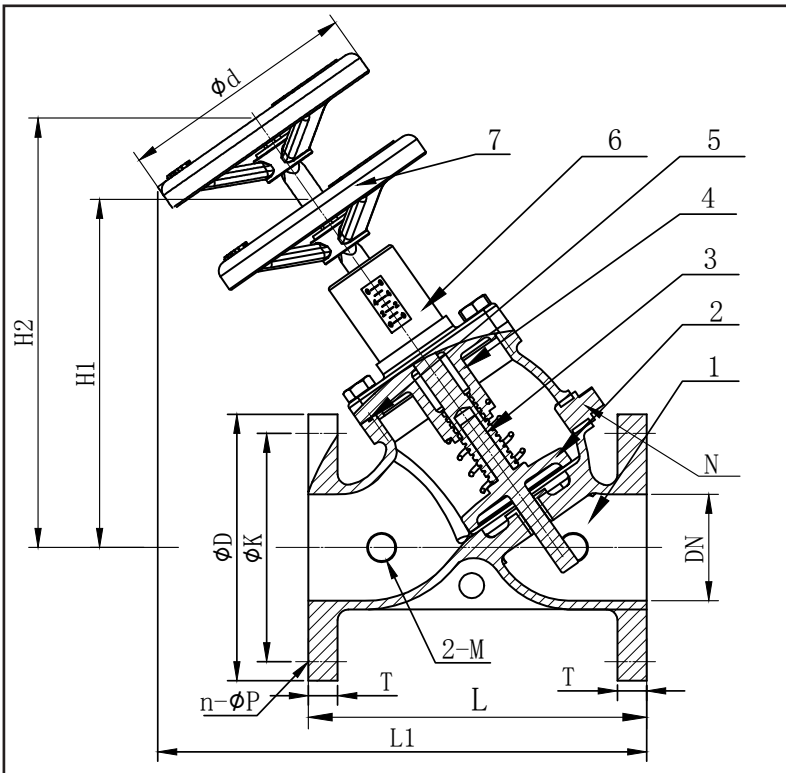

No.	Name	Material
1	Body	DI
2	Disc	DI+EPDM
3	Shaft	SS410
4	Cover	DI
5	Gasket	EPDM
6	Scale Plate	Plastic
7	Handwheel	Carbon Steel

Technical

Pressure:

Class250

Working Temp:

-20°C-120°C

-4°F -248°F

Flange to:

ANSI B16.1

Dimensions (mm/in)

√									
MFV	0200-250F	0250-250F	0300-250F	0400-250F	0500-250F	0600-250F	0800-250F	1000-250F	1200-250F
NPS	2	2 1/2	3	4	5	6	8	10	12
DN	50 1.97	65 2.56	80 3.15	100 3.94	125 4.92	150 5.90	200 7.88	250 9.84	300 11.81
L	213 8.39	250 9.84	254 10	368 14.49	407 16.02	457 17.99	546 21.50	648 25.51	762 30.00
L1	309 12.17	336 13.23	340 13.39	439 17.28	472 18.58	560 22.05	691 27.20	787 30.98	951 37.44
H1	226 8.90	240 9.45	257 10.12	295 11.61	330 12.99	352 13.85	530 20.87	589 23.19	691 27.20
H2	251 9.88	265 10.43	282 11.10	320 12.60	363 14.29	380 14.96	579 22.80	668 26.30	809 31.85
Ø d		180 7.09			250 9.84		350 13.78		450 17.72
Ø D	165.1 6.5	190.5 7.5	209.6 8.25	254 10	279.4 11	317.5 12.5	381 15	444.5 17.5	520.7 20.5
Ø K	127 5	149.4 5.88	168.2 6.62	200.2 7.88	235 9.25	269.8 10.62	330.2 13	387.4 15.25	450.9 17.75
T	401.32 15.8	444.5 17.5	485.14 19.1	607.06 23.9		645.16 25.4	723.9 28.5	767.08 30.2	807.72 31.8
M	6.35mm - 1/4" NPT								
N	12.7mm - 1/2" NPT			25.4mm - 1" NPT					
Weight (kg/lbs)	13.2 29.10	16 35.27	20.5 45.19	40 88.18	53 116.85	68 149.91	158 348.33	182 401.24	320 705.48

● Triple Duty Valves

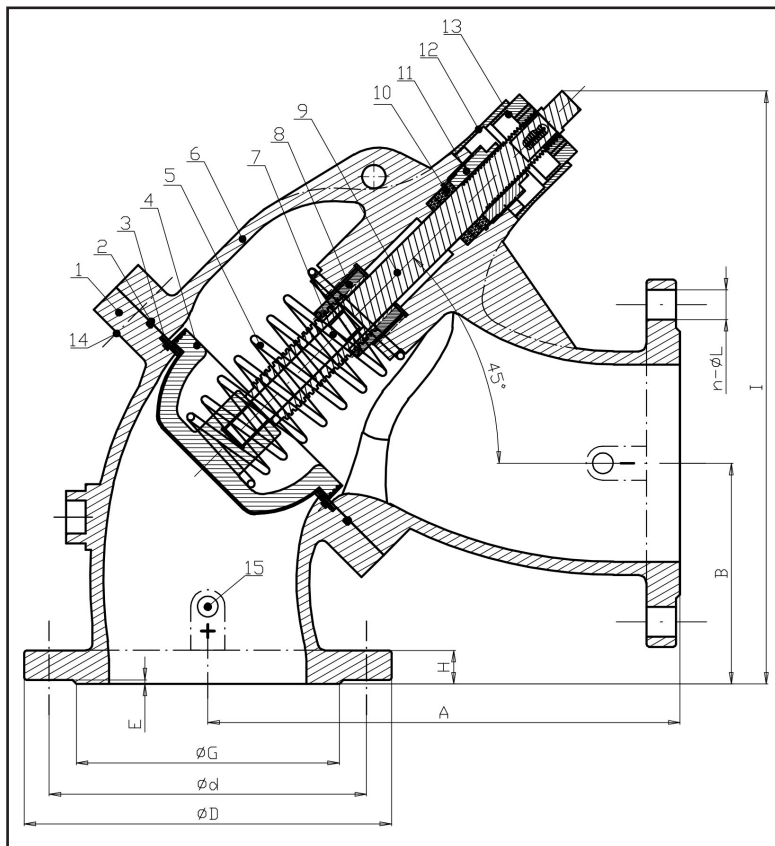

No.	Name	Qty	Material
1	Lower Body	1	DI
2	O Ring	1	NBR/EPDM
3	Seat	1	Casting Brass
4	Disc	1	CI+EPDM
5	Spring	1	SS302
6	Upper Body	1	DI
7	Disc Shaft	1	SS410
8	Shaft Nut	1	Brass
9	Shaft	1	SS410
10	Packing	3	Graphit
11	Gland	1	SS410
12	Accessories	1	Plastic
13	Accessories	1	Plastic
14	Bolt & Nut	8	WCB
15	Plug/Testing Point	4	WCB/HPb59-1

Technical

Pressure:

861.25 kPa - 1033.5 kPa

124.88 PSI - 149.82 PSI

ANSI B16.1

PN10 : 125-150 lbs

PN16 : 225-250 lbs

**See next page
for measures
in millimeters**

√	SIZE	Ø D	Ø d	H	n-ØL	ØG	E	A	B	Open	Close
	2 1/2	7.01	5.50	0.69	4-Ø.75	-	-	7.36	4.61	11.77	12.91
	DN65	7.28	5.71	0.88		4.65	.12				
	3	7.5	6	0.75	8-Ø.75	-	-	8.19	3.86	12.28	13.62
	DN80	7.87	6.3	0.94		5.20	.12				
	4	9.02	7.5	0.75	8-Ø.75	-	-	9.61	4.37	12.56	13.90
	DN100	8.66	7.09	0.94		6.14	.12				
	5	10	8.5	0.75	8-Ø.91	-	-	12.01	5.51	16.10	18.11
	DN125	9.84	8.27	1	8-Ø.75	7.24	.12				
	6	11	9.5	0.75	8-Ø.91	-	-	12.01	5.51	16.10	18.11
	DN150	11.22	9.45	1.12	8-Ø.91	8.31	.12				
	8	13.5	11.75	0.79	8-Ø.91	-	-	18.94	9.17	24.09	27.44
	DN200	13.39	11.61	1.18	12-Ø.91	10.47	.12				
	10	16	14.25	0.87	12-Ø1.02	-	-	20.31	9.76	27.44	31.46
	DN250	15.55	13.78	0.87	12-Ø.91	12.56	.12				
	12	19	17	0.96	12-Ø1.1	-	-	24.06	14.02	33.94	38.62
	DN300	17.52	15.75	0.96	12-Ø.91	14.57	.16				
		18.11	16.14	0.96	12-Ø1.1						

• Triple Duty Valves

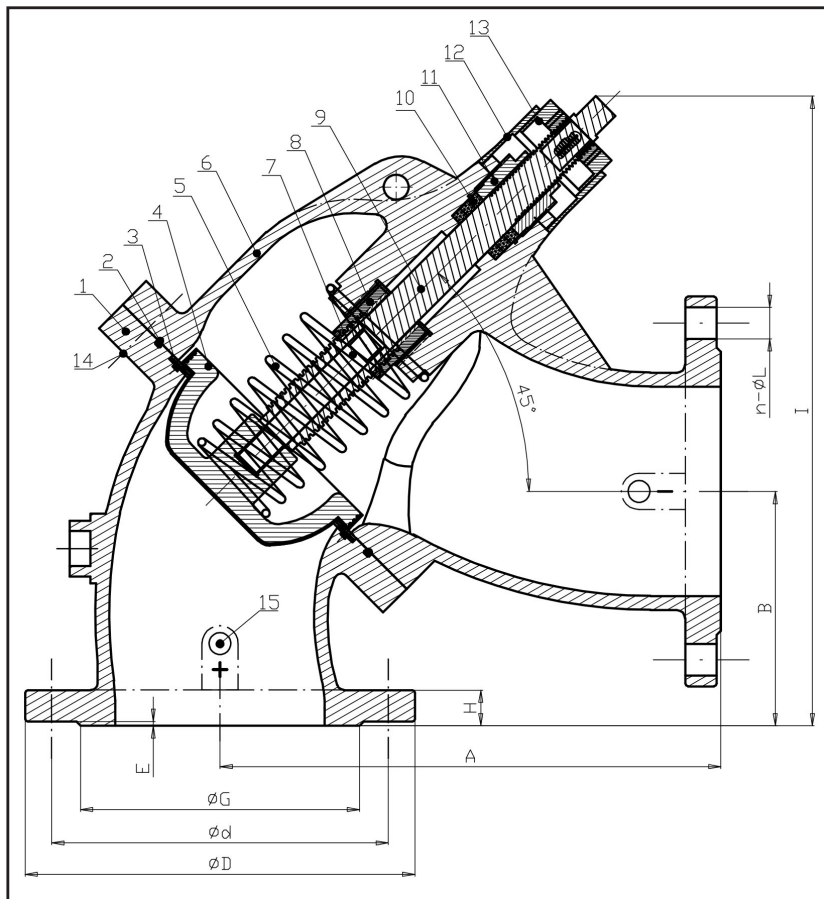

No.	Name	Qty	Material
1	Lower Body	1	DI
2	O Ring	1	NBR/EPDM
3	Seat	1	Casting Brass
4	Disc	1	CI+EPDM
5	Spring	1	SS302
6	Upper Body	1	DI
7	Disc Shaft	1	SS410
8	Shaft Nut	1	Brass
9	Shaft	1	SS410
10	Packing	3	Graphit
11	Gland	1	SS410
12	Accessories	1	Plastic
13	Accessories	1	Plastic
14	Bolt & Nut	8	WCB
15	Plug/Testing Point	4	WCB/HPb59-1

Technical

Pressure:

861.25 kPa - 1033.5 kPa
124.88 PSI - 149.82 PSI

ANSI B16.1

- PN10 : 125-150 lbs
- PN16 : 225-250 lbs

See previous page for measures in inches

√	SIZE	Ø D	Ø d	H	n-ØL	ØG	E	A	B	Open	Close
	2 1/2	178	139.7	17.6 22.4	4-Ø19	-	-	187	117	299	328
	DN65	185	145	19		118	3				
	3	190.5	152.4	19.1 24	8-Ø19	-	-	208	98	312	346
	DN80	200	160	19		132	3				
	4	229	190.5	24	8-Ø19	-	-	244	111	319	353
	DN100	220	180	19		156	3				
	5	254	215.9	23.9	8-Ø23	-	-	305	140	409	460
	DN125	250	210	19	8-Ø19	184	3				
	6	279.4	241.3	25.5	8-Ø23	-	-	359	168	451	508
	DN150	285	240	19		211	3				
	8	342.9	298.5	28.5	8-Ø23 12-Ø23	-	-	481	233	612	697
	DN200	340	295	20		266	3				
	10	406.4	362	30	12-Ø26	-	-	516	248	697	799
	DN250	395 405	350 355	22 22	12-Ø23 12-Ø28	319	3				
	12	482.6	431.8	31.8	12-Ø26	-	-	611	356	862	981
	DN300	445 460	400 410	24.5 24.5	12-Ø23 12-Ø28	370	4				

• Triple Duty Valves

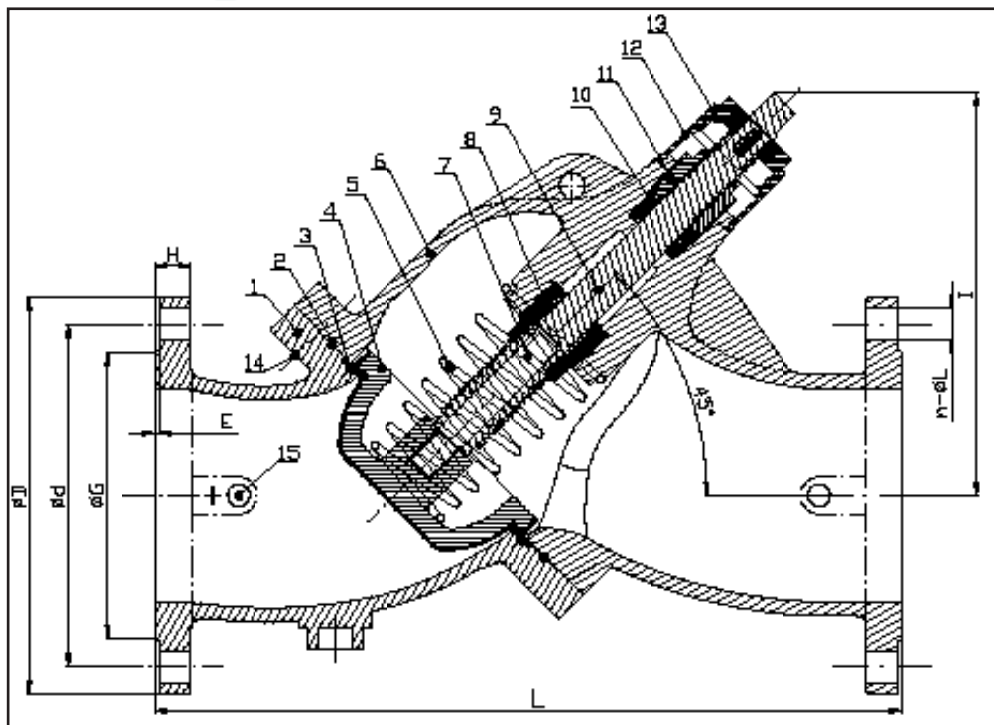

No.	Name	Qty	Material
1	Lower Body	1	DI
2	O Ring	1	NBR/EPDM
3	Seat	1	Casting Brass
4	Disc	1	CI+EPDM
5	Spring	1	SS302
6	Upper Body	1	DI
7	Disc Shaft	1	SS410
8	Shaft Nut	1	Brass
9	Shaft	1	SS410
10	Packing	3	Graphit
11	Gland	1	SS410
12	Accessories	1	Plastic
13	Accessories	1	Plastic
14	Bolt & Nut	8	WCB
15	Plug/Testing Point	4	WCB/HPb59-1

Technical

Pressure:

861.25 kPa - 1033.5 kPa

124.88 PSI - 149.82 PSI

ANSI B16.1

PN10 : 125-150 lbs

PN16 : 225-250 lbs

√	SIZE	Ø D	Ø d	H	n-ØL	ØG	E	L	Open	Close
	2 1/2	7.01	5.50	0.69 0.88	4-Ø.75	-	-	11.97	7.17	8.31
	DN65	7.28	5.71	0.75		4.65	.12			
	3	7.5	6	0.75 0.94	8-Ø.75	-	-	12.01	8.43	9.76
	DN80	7.87	6.3	0.75		5.20	.12			
	4	9.02	7.5	0.94	8-Ø.75	-	-	13.98	8.19	9.53
	DN100	8.66	7.09	0.75		6.14	.12			
	5	10	8.5	0.94	8-Ø.91	-	-	17.52	10.55	12.56
	DN125	9.84	8.27	0.75	8-Ø.75	7.24	.12			
	6	11	9.5	1	8-Ø.91	-	-	20.67	11.18	13.43
	DN150	11.22	9.45	0.75		8-Ø.91	8.31			
	8	13.5	11.75	1.12	8-Ø.91 12-Ø.91	-	-	28.19	14.92	18.27
	DN200	13.39	11.61	0.79		8-Ø.91	10.47			
	10	16	14.25	1.18	12-Ø1.02	-	-	30	17.72	22.40
	DN250	15.55	13.78	0.87	12-Ø.91	12.56	.12			
		15.94	13.98	0.87	12-Ø1.1	-	-	38.07	19.96	24.65
	12	19	17	1.25	12-Ø1.02	-	-			
	DN300	17.52	15.75	0.96	12-Ø.91	14.57	.16	38.07	19.96	24.65
		18.11	16.14	0.96	12-Ø1.1					

See next page
for
measures in
millimeters

● Triple Duty Valves

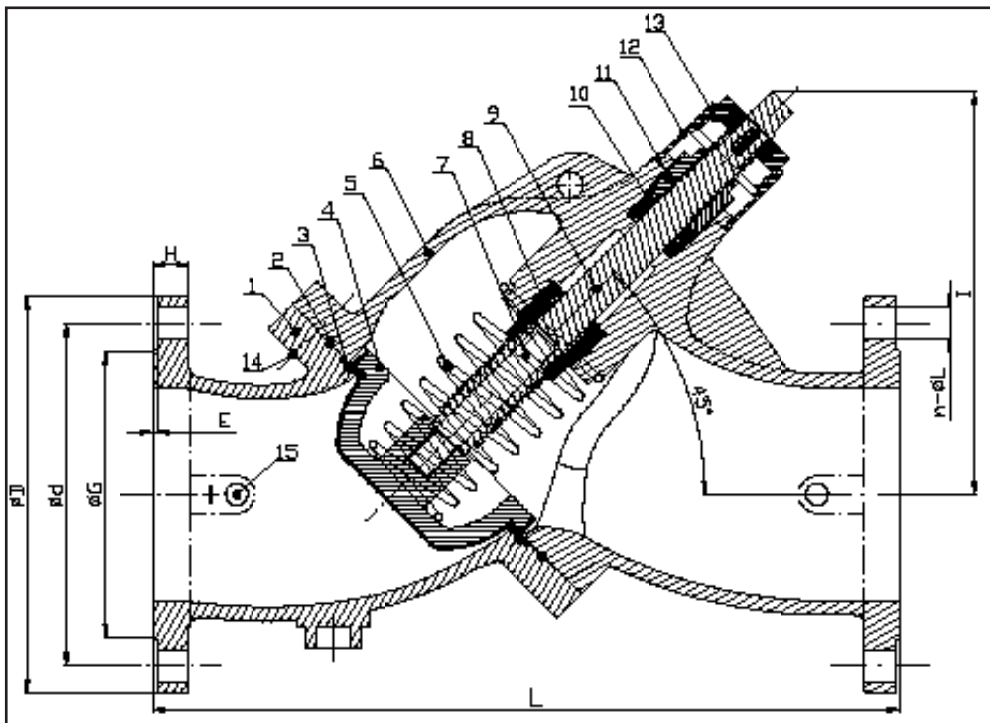

No.	Name	Qty	Material
1	Lower Body	1	DI
2	O Ring	1	NBR/EPDM
3	Seat	1	Casting Brass
4	Disc	1	CI+EPDM
5	Spring	1	SS302
6	Upper Body	1	DI
7	Disc Shaft	1	SS410
8	Shaft Nut	1	Brass
9	Shaft	1	SS410
10	Packing	3	Graphit
11	Gland	1	SS410
12	Accessories	1	Plastic
13	Accessories	1	Plastic
14	Bolt & Nut	8	WCB
15	Plug/Testing Point	4	WCB/HPb59-1

✓	Dimensions (mm)									
SIZE	Ø D	Ø d	H	n-ØL	ØG	E	L	Open	Close	
2 1/2	178	139.7	17.6	4-Ø19	-	-	304	182	211	
			22.4							
DN65	185	145	19	8-Ø19	118	3	305	214	248	
3	190.5	152.4	19.1		-	-				
			24							
DN80	200	160	19	8-Ø19	132	3	355	208	242	
4	229	190.5	24		-	-				
DN100	220	180	19	8-Ø23	156	3	445	268	319	
5	254	215.9	23.9		-	-				
DN125	250	210	19	8-Ø23	184	3	525	284	341	
6	279.4	241.3	25.5		-	-				
DN150	285	240	19	8-Ø23	211	3	716	379	464	
8	342.9	298.5	28.5		-	-				
DN200	340	295	20	8-Ø23	266	3	762	450	569	
				12-Ø23						
10	406.4	362	30	12-Ø26	-	-	967	507	626	
				12-Ø23						
				12-Ø28						
DN250	395	350	22	12-Ø23	319	3	967	507	626	
				12-Ø28						
12	482.6	431.8	31.8	12-Ø26	-	-	967	507	626	
				12-Ø23						
DN300	445	400	24.5	12-Ø23	370	4	967	507	626	
				12-Ø28						

Technical

Pressure:

861.25 kPa - 1033.5 kPa
124.88 PSI - 149.82 PSI

ANSI B16.1

- PN10 : 125-150 lbs
- PN16 : 225-250 lbs

See previous page for measures in inches



● Features

Low Pressure Drop

The multi-function valve streamlined design results in low pressure drop making it extremely energy efficient.

Control

Greater range of control allows precise flow control versus On-Off throttling valves.

Positive Shut-Off

Without valve chattering. These valves are positive shut-off valves, when using MFV valves, other types of valves are not required

Calibrated Nameplate

The multi-function valve allows you to return to the balance position after shutting it off.

Durability

Bronze seat and disc with stainless steel stem construction ensure long life and reliability.

Design

The multi-function valve is a double regulating, control and shut-off valve with a built in pressure drop measuring in-line flow. Balancing problems are quite evident in a system, like central air conditioning plants and in process heat exchangers. The MFV valve is a combination of a shut-off valve (gate / plug / ball / butterfly valve) plus a flow regulating (globe style valve), a flow measuring station. It is not merely a valve but a system control valve in itself. It provides a scientific basis for flow balancing in a system with database. The valves are used HVAC systems and other process applications wherever balancing is required. Balancing is done to improve the performance of a closed circuit, forced circulation water in the system for heating and cooling. Balancing makes the building provide the desired indoor climate under all operating conditions at minimum energy cost. Balancing is a matter of adjusting pressure drops to get the precise required flow of water in a circuit. Balancing reduces energy costs by almost 10% to 40% by reducing average temperature in a heating system and increasing average temperature in a cooling system with less energy for pumping. Replacing three valves with one MFV-F (flange) or MFV-G (grooved) valves can dramatically reduce your up-front material and labor costs

Spring Loaded Clapper

Allows the Multi-function valve to be installed horizontally or vertically upward. In-line

Serviceability

Allows easy maintenance and replacement without disturbing the piping.

Benefits

- 1) Using a multifunction valve avoid user's complaints with unbalanced heating or cooling systems in different parts of the building.
- 2) Easy correction of system design and installation errors
- 3) Better accuracy of flow measurement
- 4) Economic; system components like boilers/chillers don't have to be oversized for possible errors and varying conditions. A balanced system only needs the actually required flows which is usually less than system when not balanced.



2" MULTI-FUNCTION VALVE "MFV" FLOW DIAGRAM (FLANGED & GROOVED)

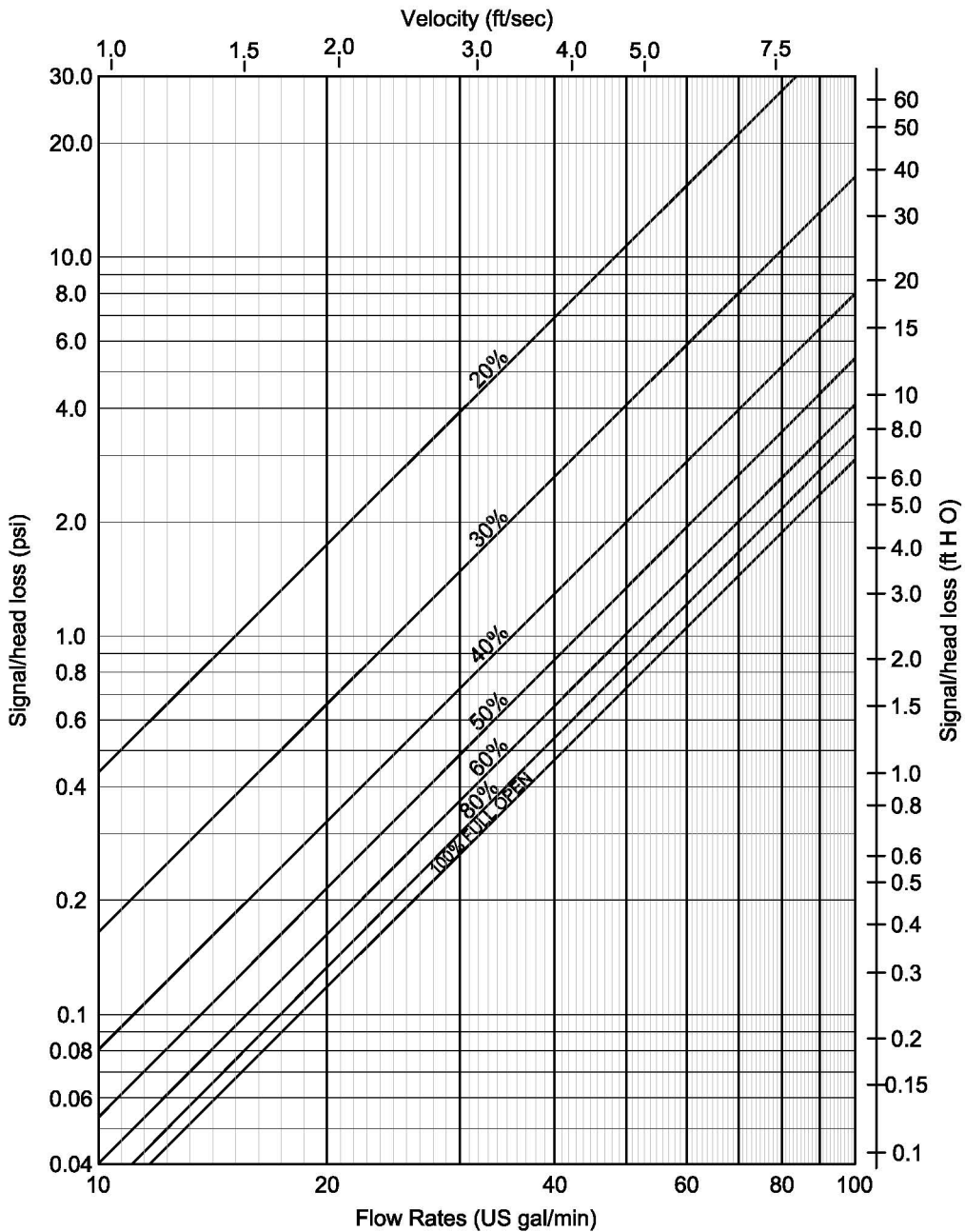

Graph of signal/Head Loss against Flow Rate indicating pressure drop attributable to the valve installed in a circuit.
Velocity based on average inside diameter of Schedule 40 pipe.

NOTE:
MULTI-FUNCTION VALVES PROVIDES REGULATION AND FLOW MEASUREMENT WITHIN AN ACCURACY OF 25%.





2-1/2' MULTI-FUNCTION VALVE "MFV" FLOW DIAGRAM (FLANGED & GROOVED)

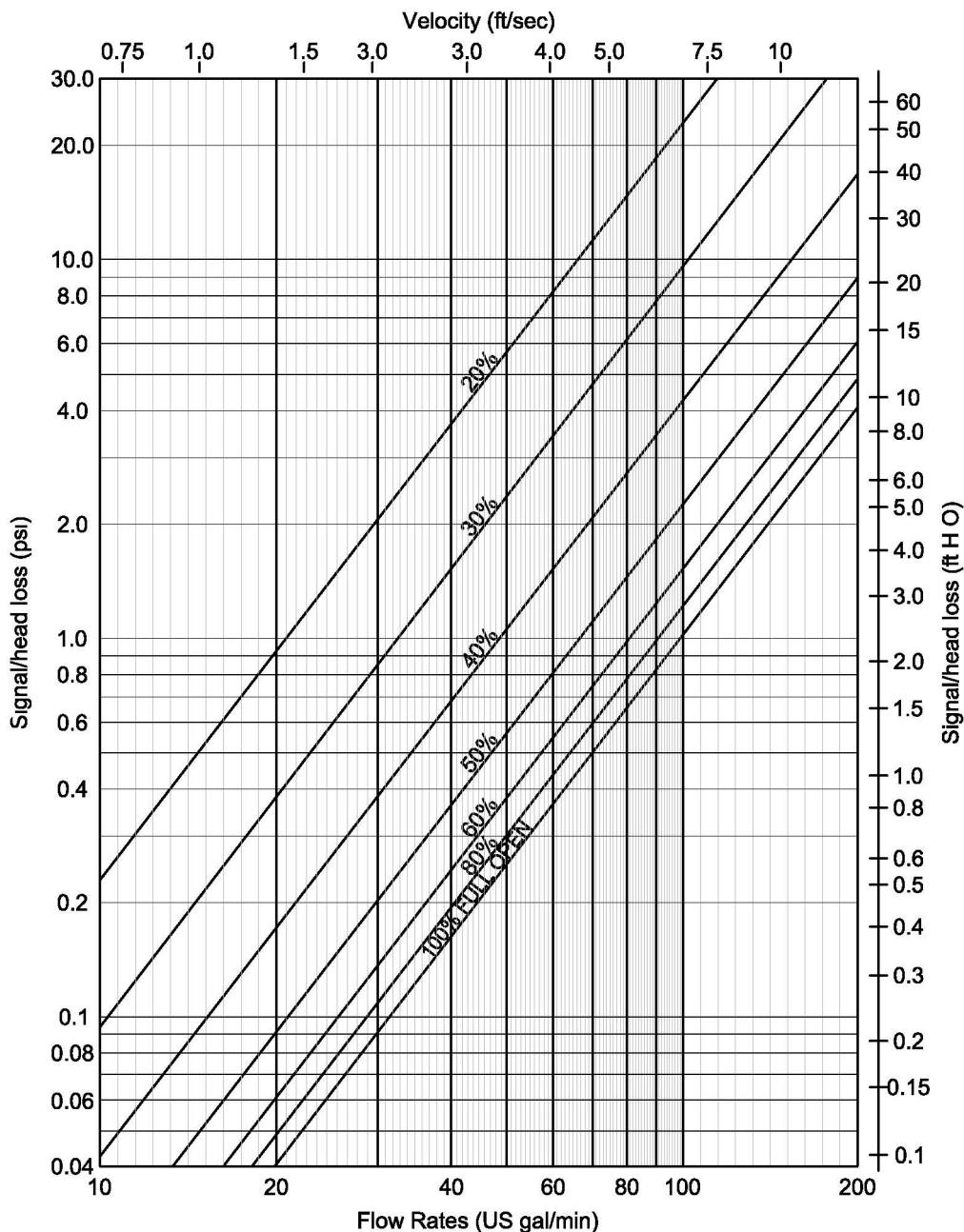

Graph of signal/Head Loss against Flow Rate indicating pressure drop attributable to the valve installed in a circuit.
Velocity based on average inside diameter of Schedule 40 pipe.

NOTE:

MULTI-FUNCTION VALVES PROVIDES REGULATION AND FLOW MEASUREMENT WITHIN AN ACCURACY OF 25%.



3" MULTI-FUNCTION VALVE "MFV" FLOW DIAGRAM (FLANGED & GROOVED)

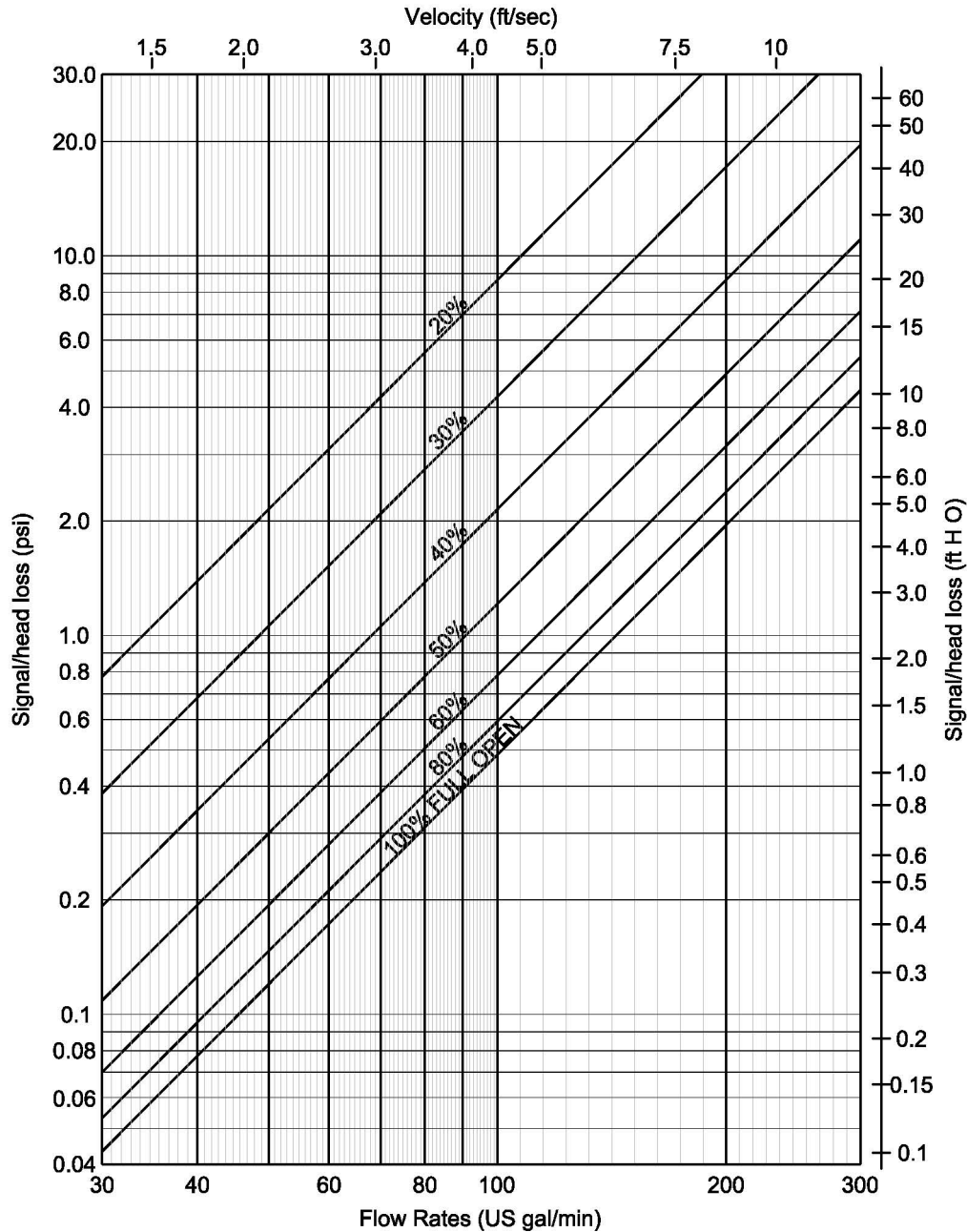

Graph of signal/Head Loss against Flow Rate indicating pressure drop attributable to the valve installed in a circuit.
 Velocity based on average inside diameter of Schedule 40 pipe.

NOTE:

MULTI-FUNCTION VALVES PROVIDES REGULATION AND FLOW MEASUREMENT WITHIN AN ACCURACY OF 25%.



4" MULTI-FUNCTION VALVE "MFV" FLOW DIAGRAM (FLANGED & GROOVED)

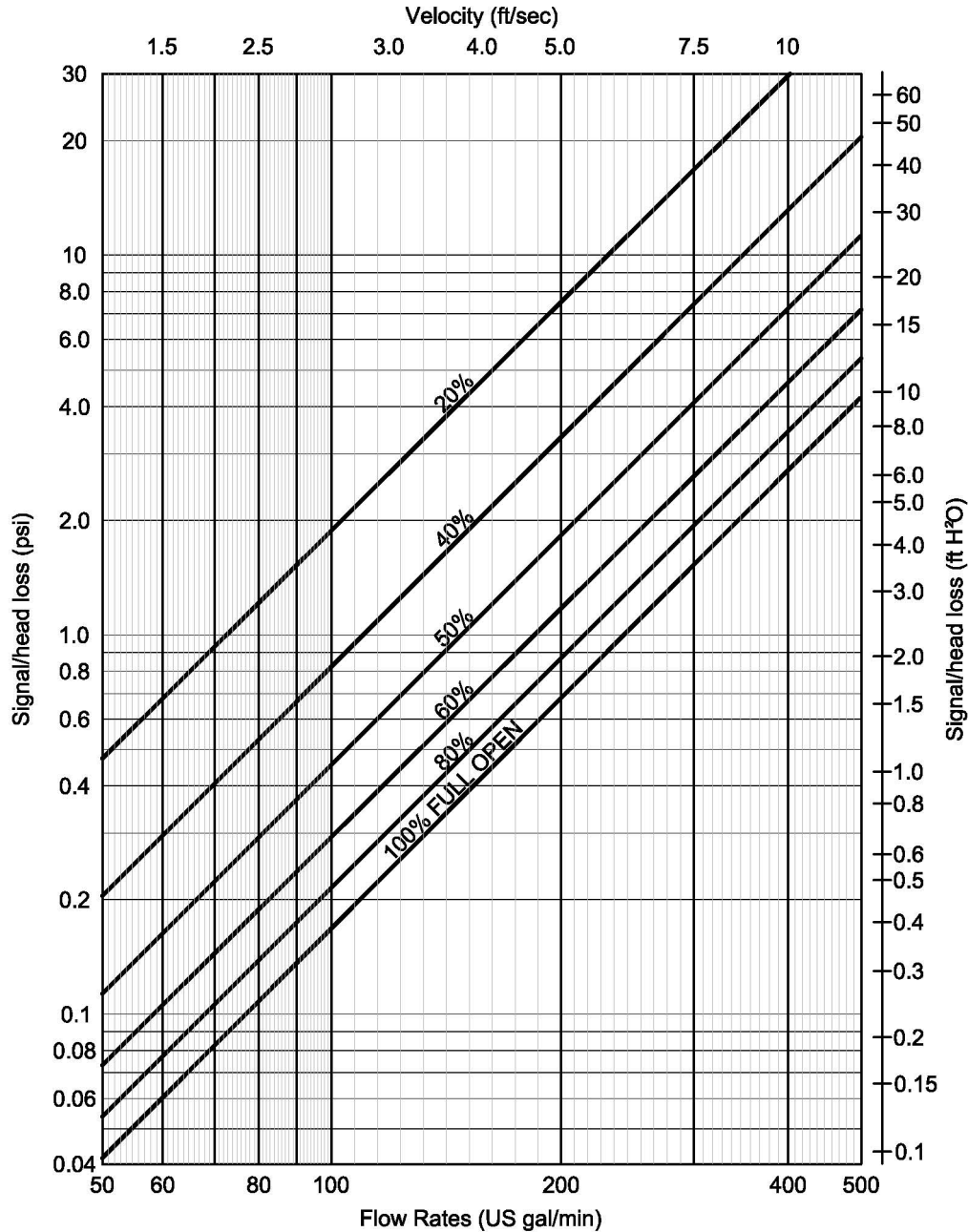

Graph of signal/Head Loss against Flow Rate indicating pressure drop attributable to the valve installed in a circuit.
Velocity based on average inside diameter of Schedule 40 pipe.

NOTE:
MULTIFUNCTION VALVES PROVIDES REGULATION AND FLOW MEASUREMENT WITHIN AN ACCURACY OF 25%.

5" MULTI-FUNCTION VALVE "MFV" FLOW DIAGRAM (FLANGED & GROOVED)

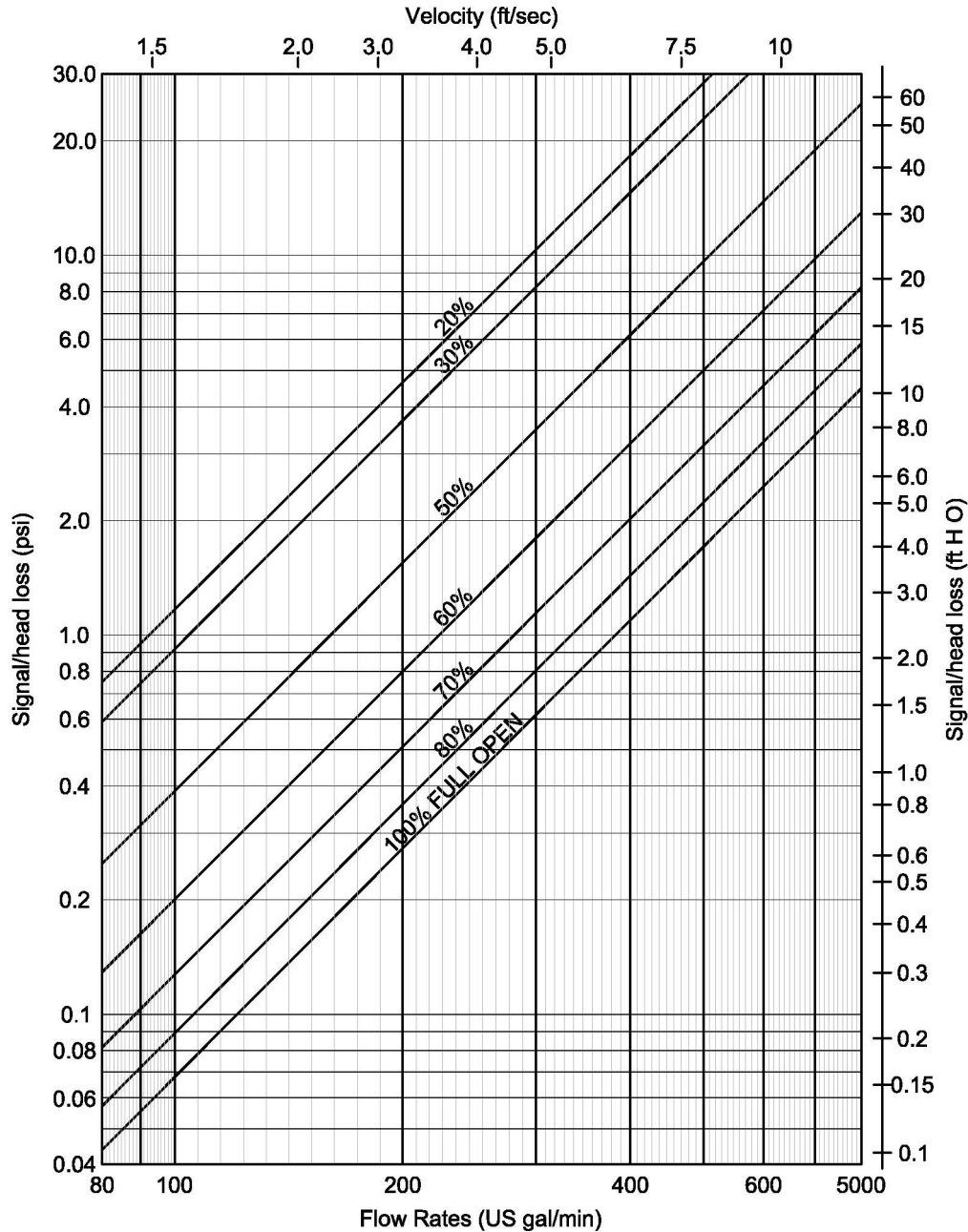

Graph of signal/Head Loss against Flow Rate indicating pressure drop attributable to the valve installed in a circuit.
 Velocity based on average inside diameter of Schedule 40 pipe.

NOTE:

MULTI-FUNCTION VALVES PROVIDES REGULATION AND FLOW MEASUREMENT WITHIN AN ACCURACY OF 25%.



6" MULTI-FUNCTION VALVE "MFV" FLOW DIAGRAM (FLANGED & GROOVED)

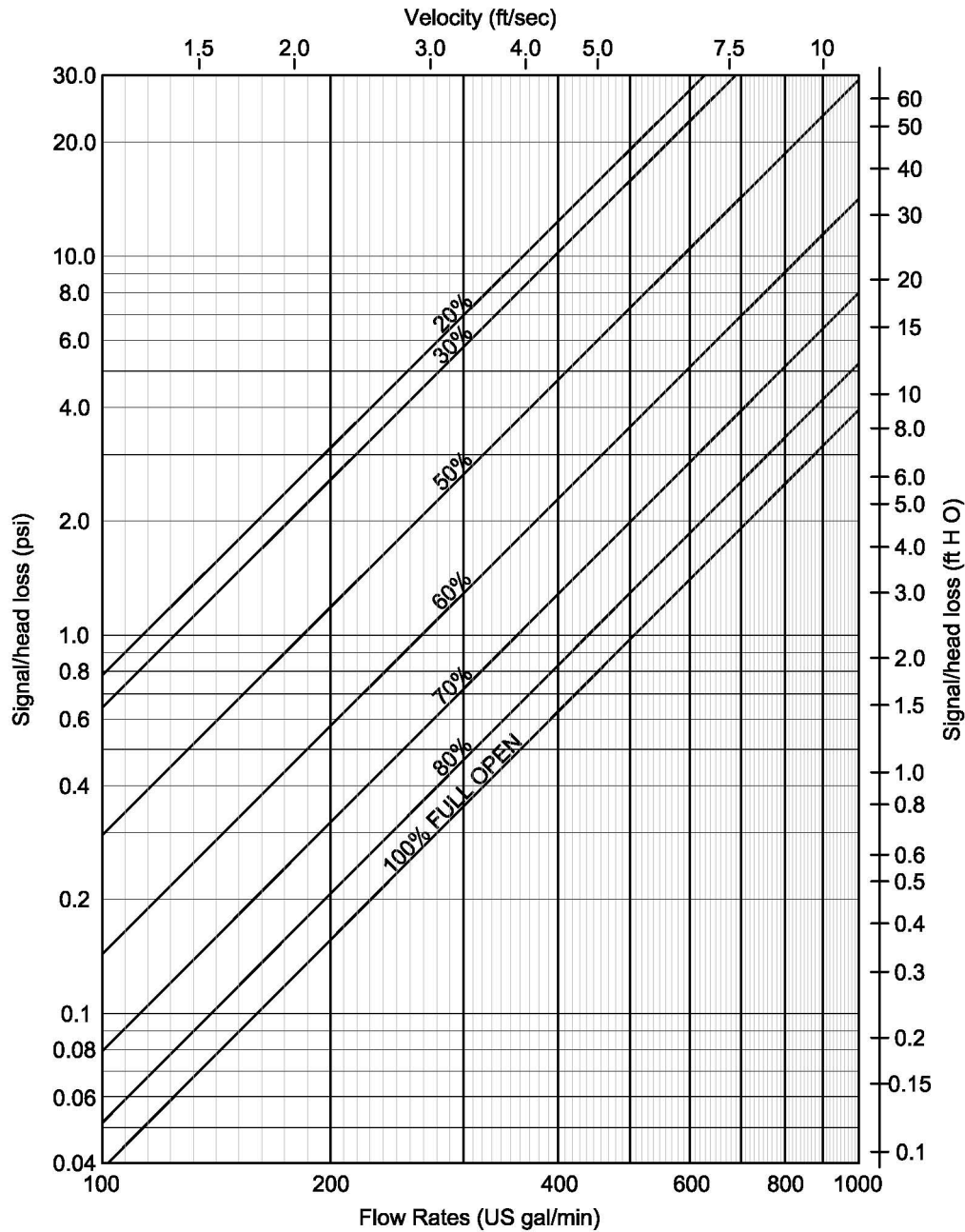

Graph of signal/Head Loss against Flow Rate indicating pressure drop attributable to the valve installed in a circuit.

Velocity based on average inside diameter of Schedule 40 pipe.

NOTE:

MULTI-FUNCTION VALVES PROVIDES REGULATION AND FLOW MEASUREMENT WITHIN AN ACCURACY OF 25%.



8" MULTI-FUNCTION VALVE "MFV" FLOW DIAGRAM (FLANGED & GROOVED)

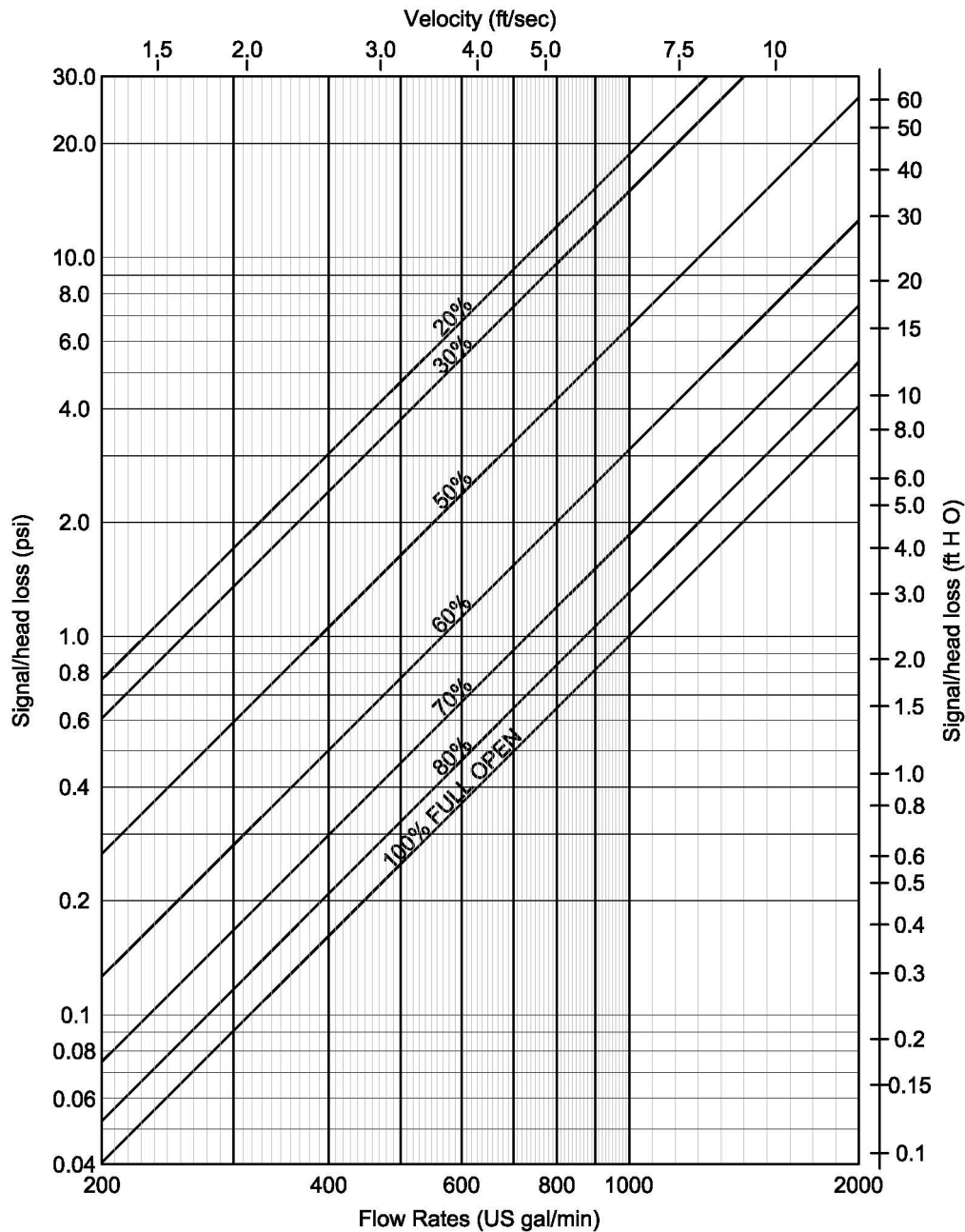

Graph of signal/Head Loss against Flow Rate indicating pressure drop attributable to the valve installed in a circuit.
Velocity based on average inside diameter of Schedule 40 pipe.

NOTE:

MULTI-FUNCTION VALVES PROVIDES REGULATION AND FLOW MEASUREMENT WITHIN AN ACCURACY OF 25%.





10" MULTI-FUNCTION VALVE "MFV" FLOW DIAGRAM (FLANGED & GROOVED)

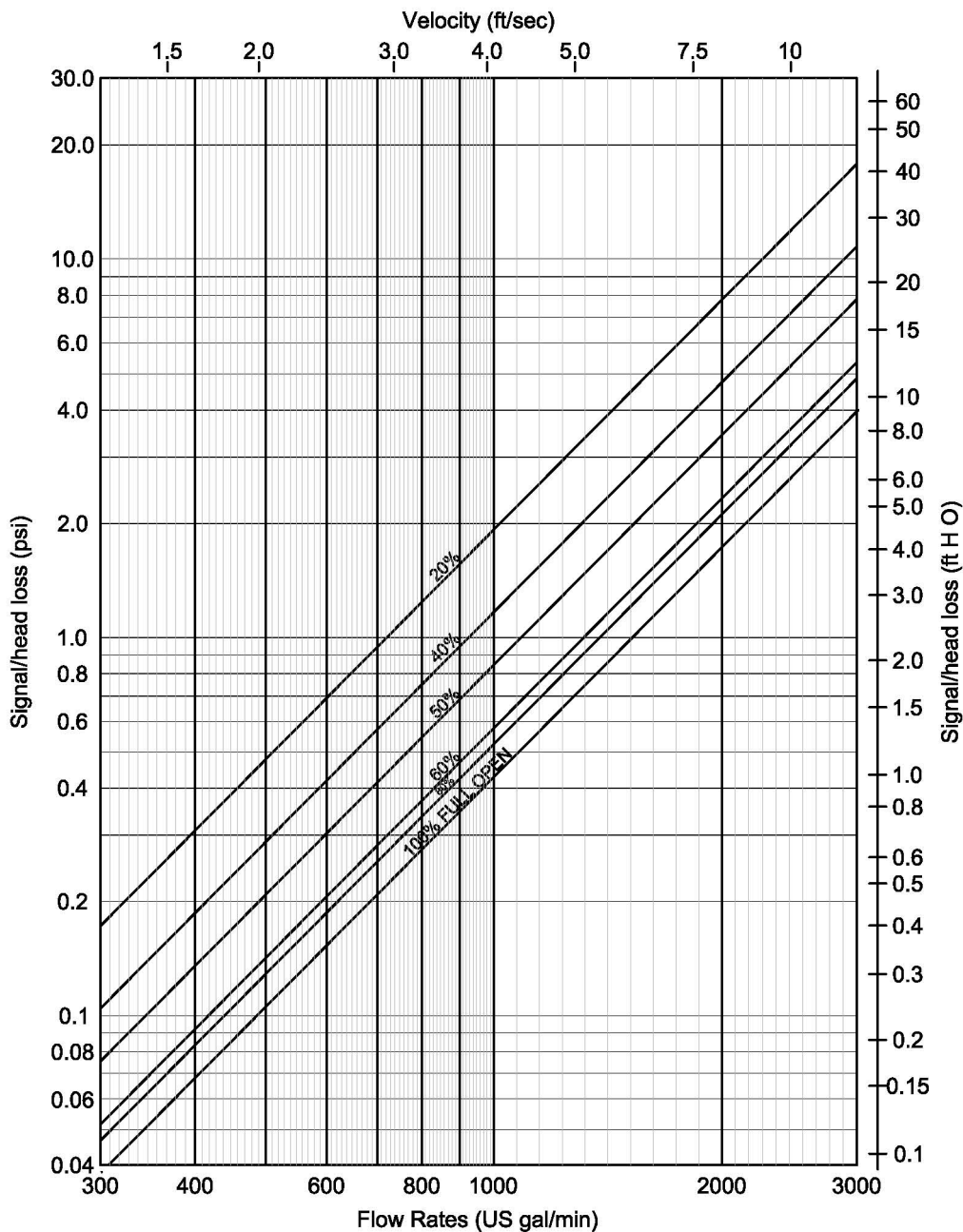

Graph of signal/Head Loss against Flow Rate indicating pressure drop attributable to the valve installed in a circuit.
Velocity based on average inside diameter of Schedule 40 pipe.

NOTE:
MULTI-FUNCTION VALVES PROVIDES REGULATION AND FLOW MEASUREMENT WITHIN AN ACCURACY OF 25%.

12" MULTI-FUNCTION VALVE "MFV" FLOW DIAGRAM (FLANGED & GROOVED)

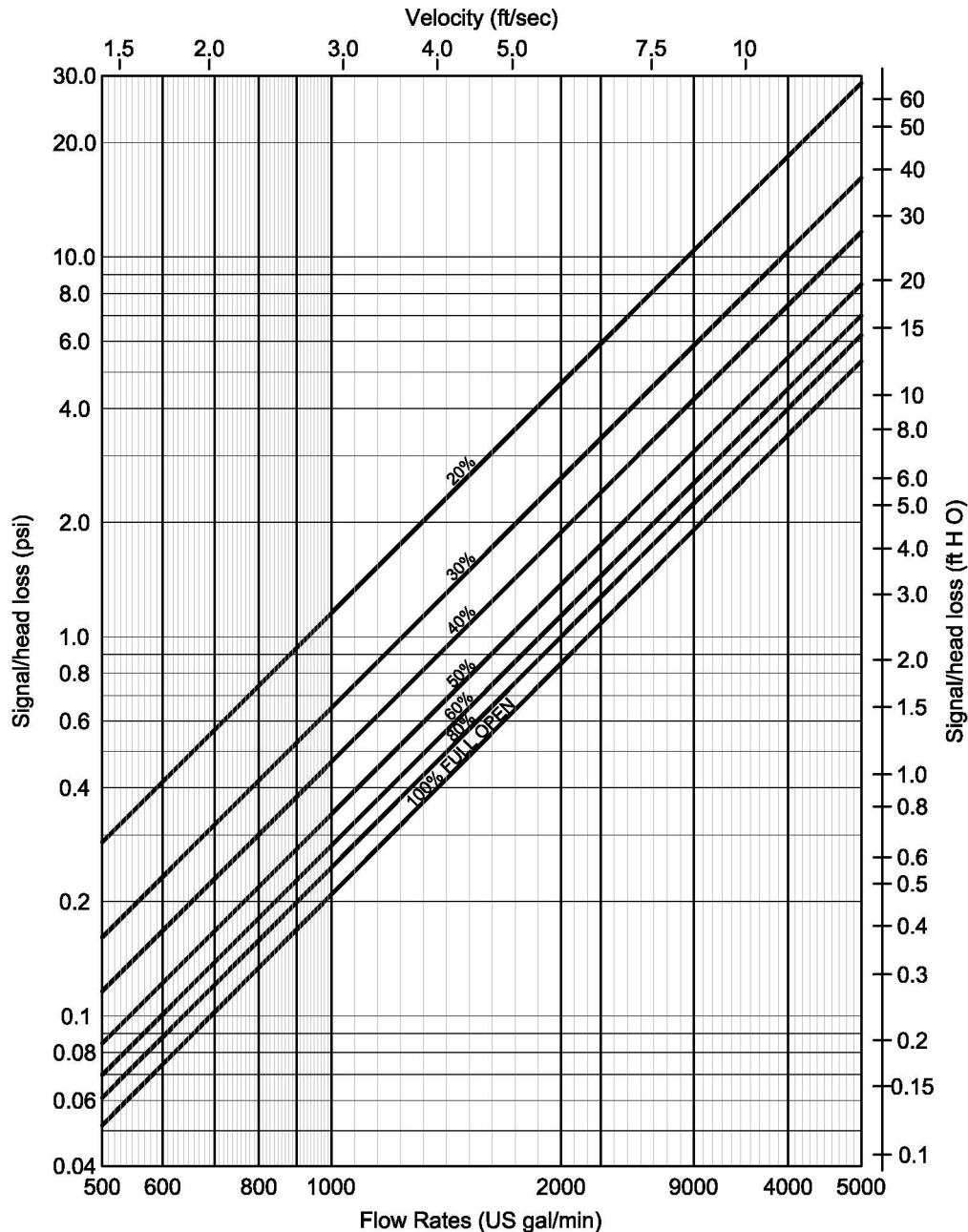

Graph of signal/Head Loss against Flow Rate indicating pressure drop attributable to the valve installed in a circuit.
 Velocity based on average inside diameter of Schedule 40 pipe.

NOTE:
 MULTI-FUNCTION VALVES PROVIDES REGULATION AND
 FLOW MEASUREMENT WITHIN AN ACCURACY OF 25%.

SUBMITTAL DATA SHEET
 ISSUE DATE : MAY 2008
 REVISION : OCTOBER 2008

14" MULTI-FUNCTION VALVE "MFV"

FLOW DIAGRAM

(FLANGED & GROOVED)

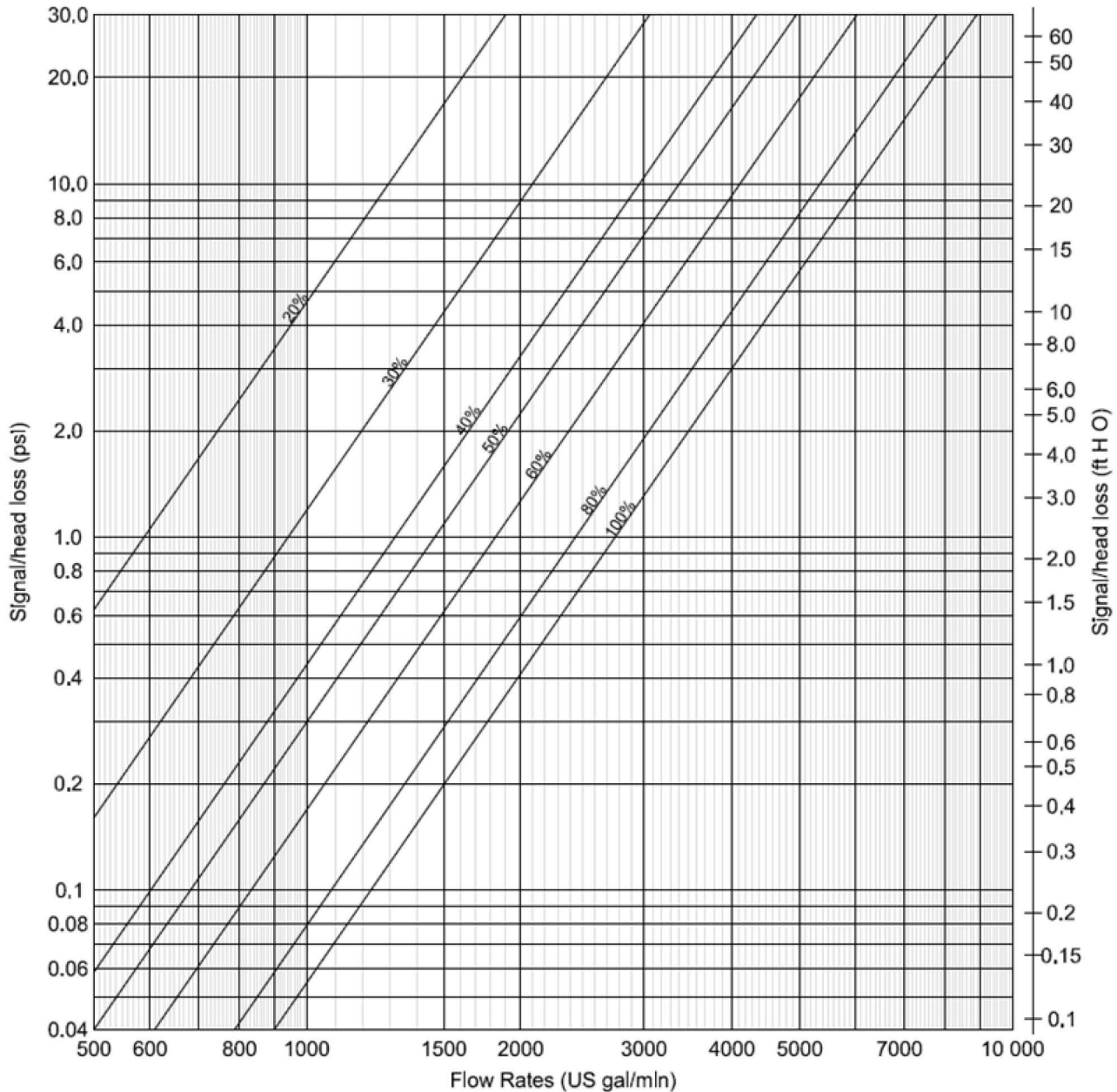

Graph of signal/head loss against flow rate indicating pressure drop attributable to the valve installed in a circuit.
 Velocity based on average inside diameter of schedule 40 pipe.

NOTE:
 MULTI-FUNCTION VALVES PROVIDES REGULATION AND FLOW MEASUREMENT WITHIN AN ACCURACY OF 25%.

SUBMITTAL DATA SHEET
 ISSUE DATE : MAY 2008
 REVISION : OCTOBER 2008

16" MULTI-FUNCTION VALVE "MFV"
FLOW DIAGRAM
(FLANGED & GROOVED)

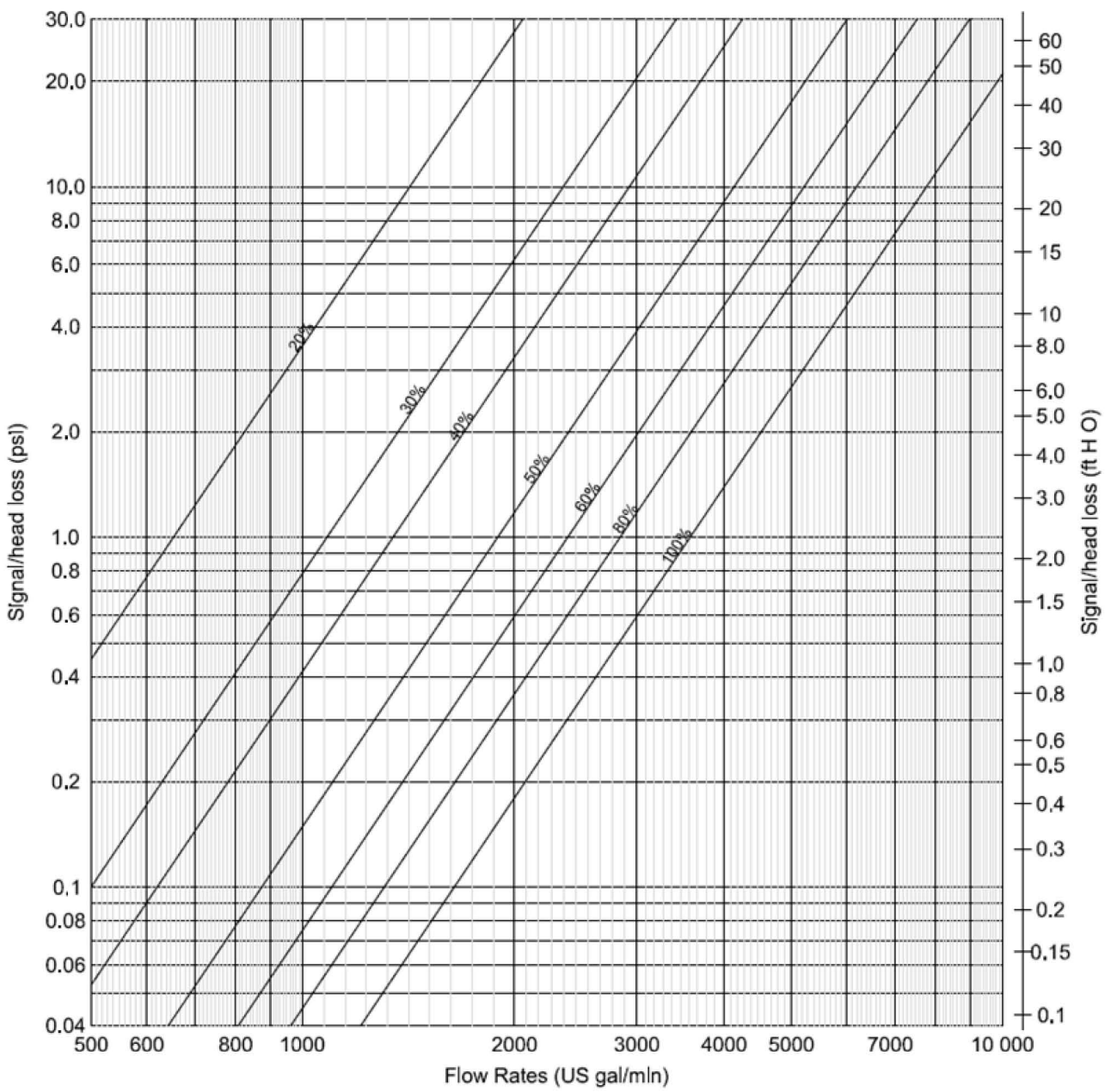

Graph of signal/head loss against flow rate indicating pressure drop attributable to the valve installed in a circuit.
 Velocity based on average inside diameter of schedule 40 pipe.

NOTE: MULTI-FUNCTION VALVES PROVIDES REGULATION AND FLOW MEASUREMENT WITHIN AN ACCURACY OF 25%

18" MULTI-FUNCTION VALVE "MFV" FLOW DIAGRAM (FLANGED & GROOVED)

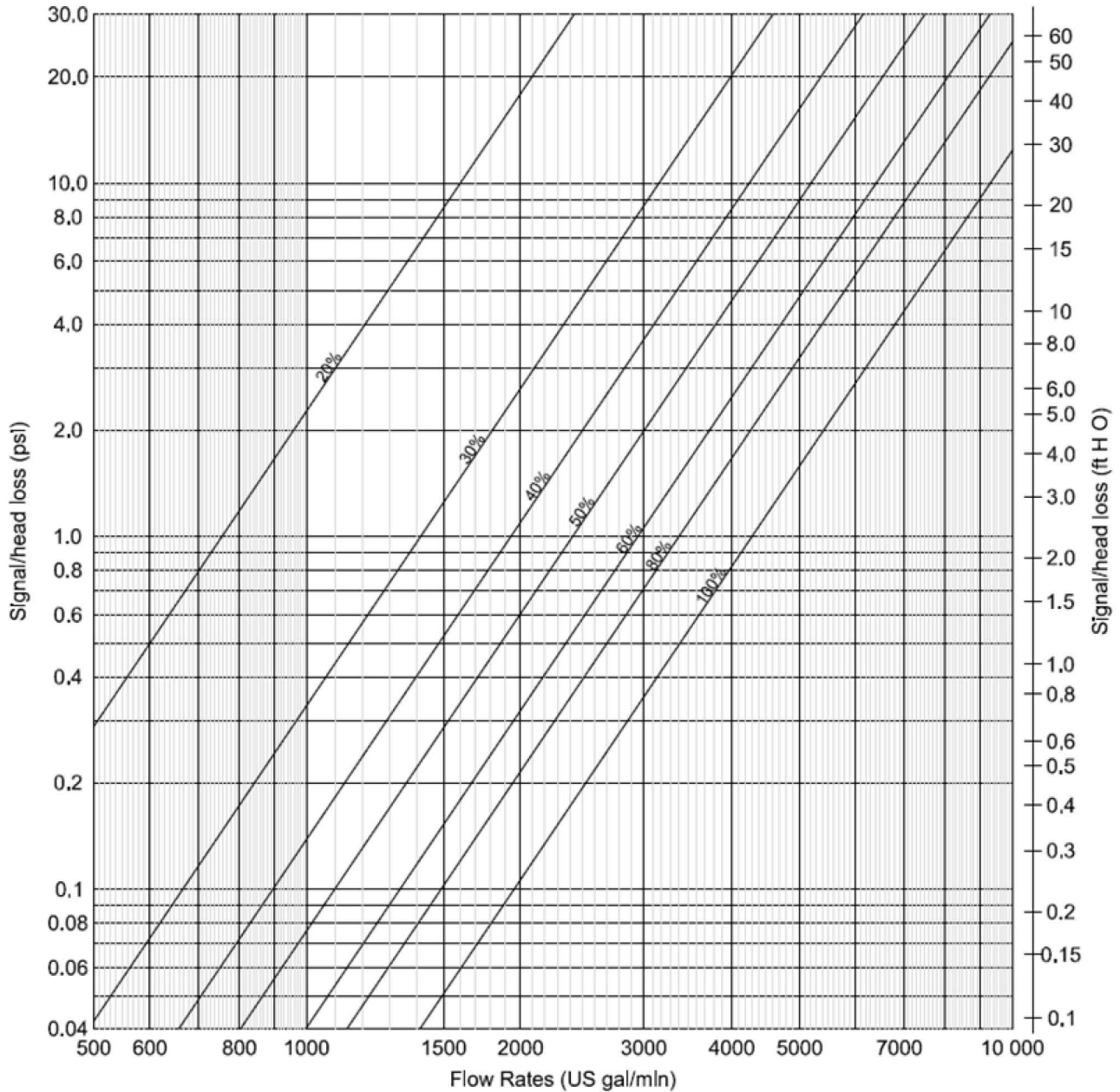

Graph of signal/head loss against flow rate indicating pressure drop attributable to the valve installed in a circuit.
 Velocity based on average inside diameter of schedule 40 pipe.

NOTE: MULTI-FUNCTION VALVES PROVIDES REGULATION AND FLOW MEASUREMENT WITHIN AN ACCURACY OF 25%



● Performance Curves

MFV1400-150F

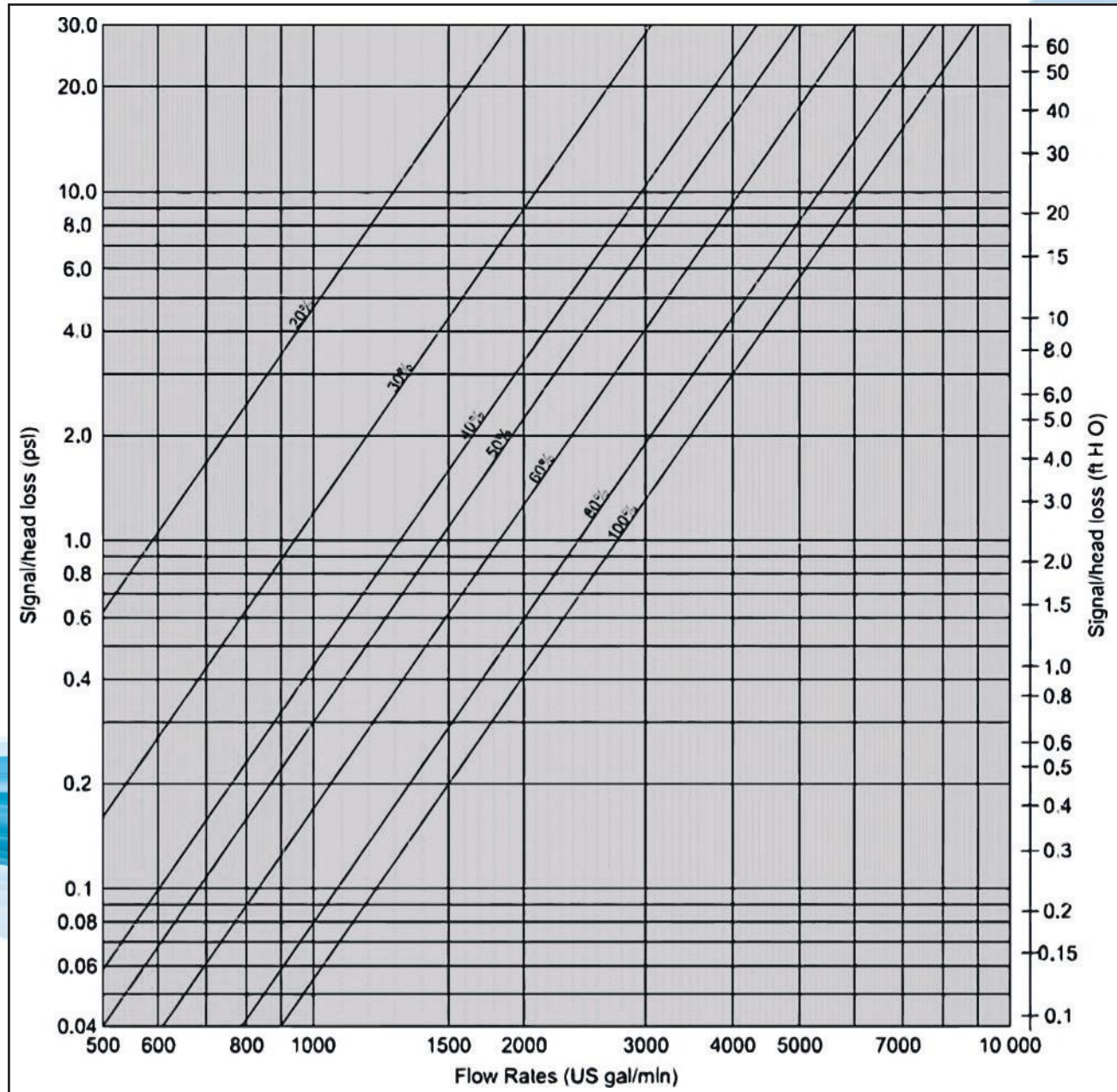

Graph of signal. Head Loss against Flow Rate indicating pressure drop attributable to the valve installed in a circuit.

Velocity based on average inside diameter of Schedule 40 pipe.

NOTE: MULTI-FUNCTION VALVES PROVIDES REGULATION AND FLOW MEASUREMENT WITHIN ACCURACY OF 25 %



● Performance Curves
MFV1600-150F

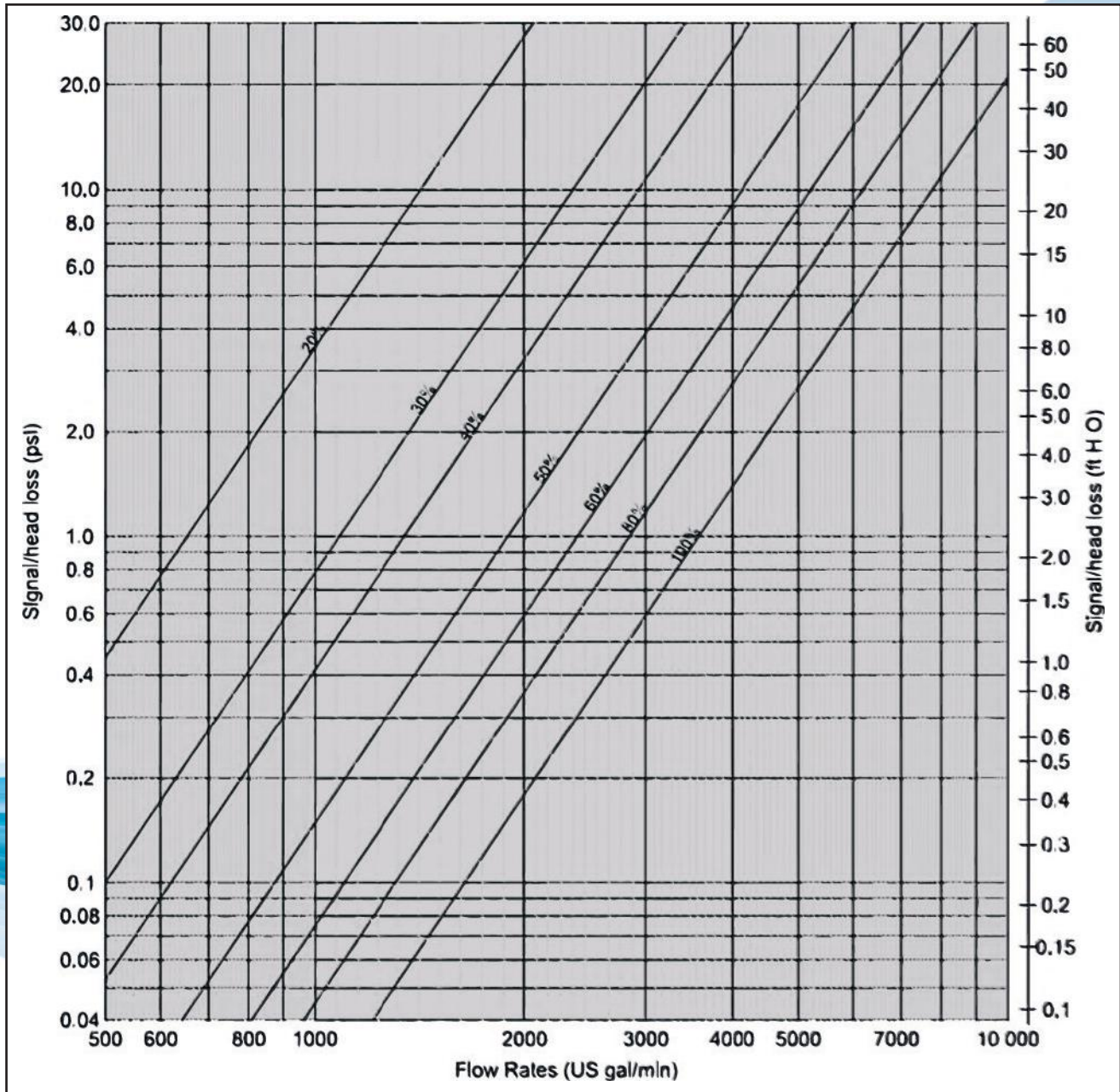

Graph of signal. Head Loss against Flow Rate indicating pressure drop attributable to the valve installed in a circuit.

Velocity based on average inside diameter of Schedule 40 pipe.

NOTE: MULTI-FUNCTION VALVES PROVIDES REGULATION AND FLOW MEASUREMENT WITHIN ACCURACY OF 25 %



● Performance Curves

MFV1800-150F

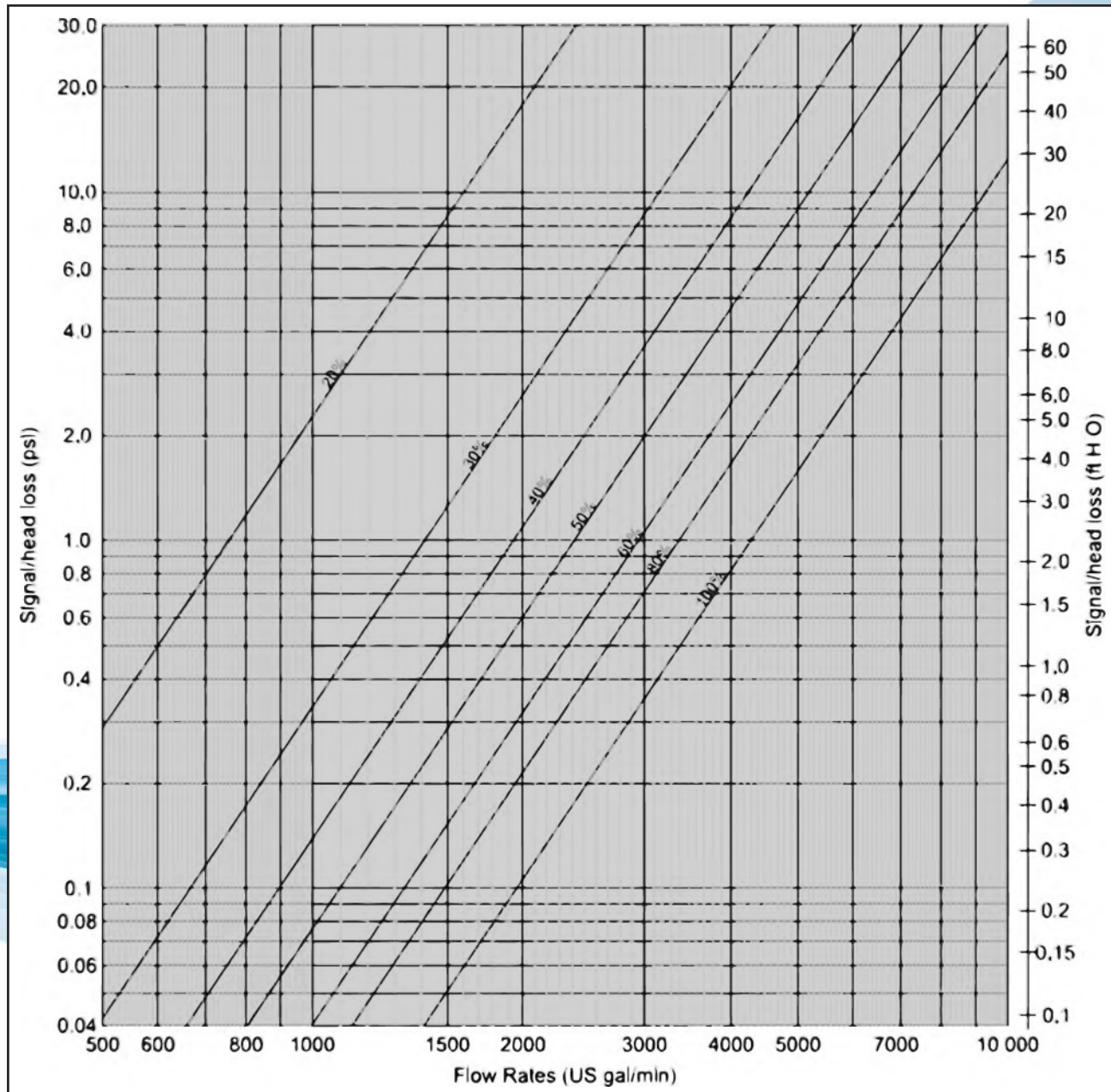

Graph of signal. Head Loss against Flow Rate indicating pressure drop attributable to the valve installed in a circuit.

Velocity based on average inside diameter of Schedule 40 pipe.

NOTE: MULTI-FUNCTION VALVES PROVIDES REGULATION AND FLOW MEASUREMENT WITHIN ACCURACY OF 25 %

Typical Piping Details Series MFV-F & MFV-G

FRAME MOUNTED

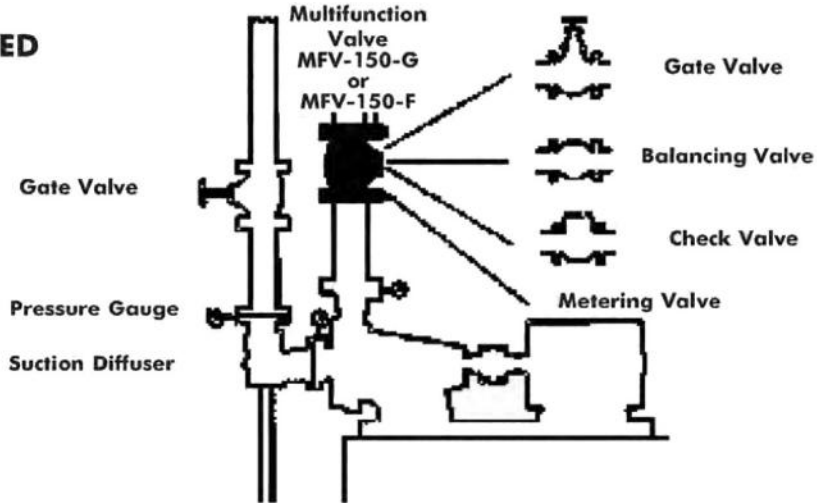

IN-LINE

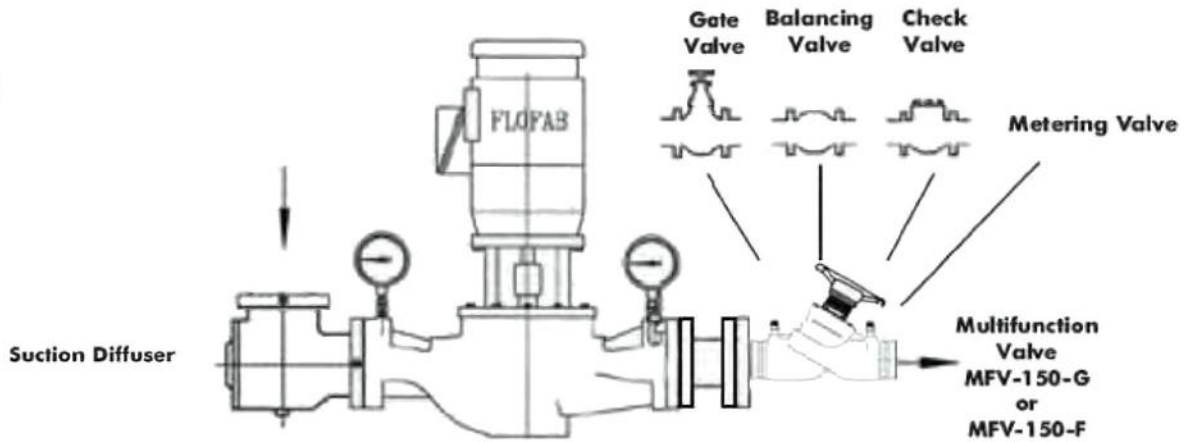

DOUBLE SUCTION SPLIT CASE

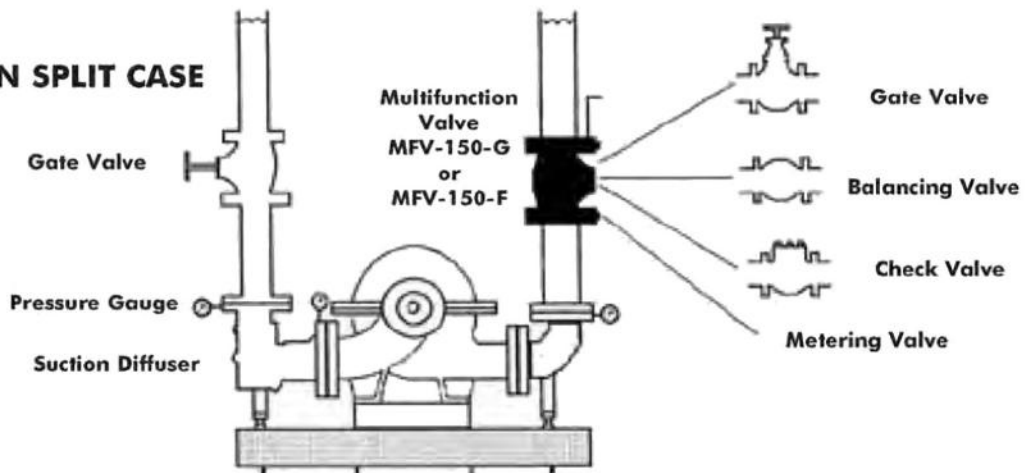

RECOMMENDED PIPING LENGTH FOR INSTALLATION

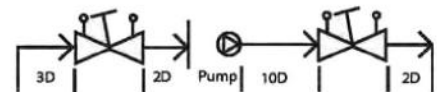

- **Other System**

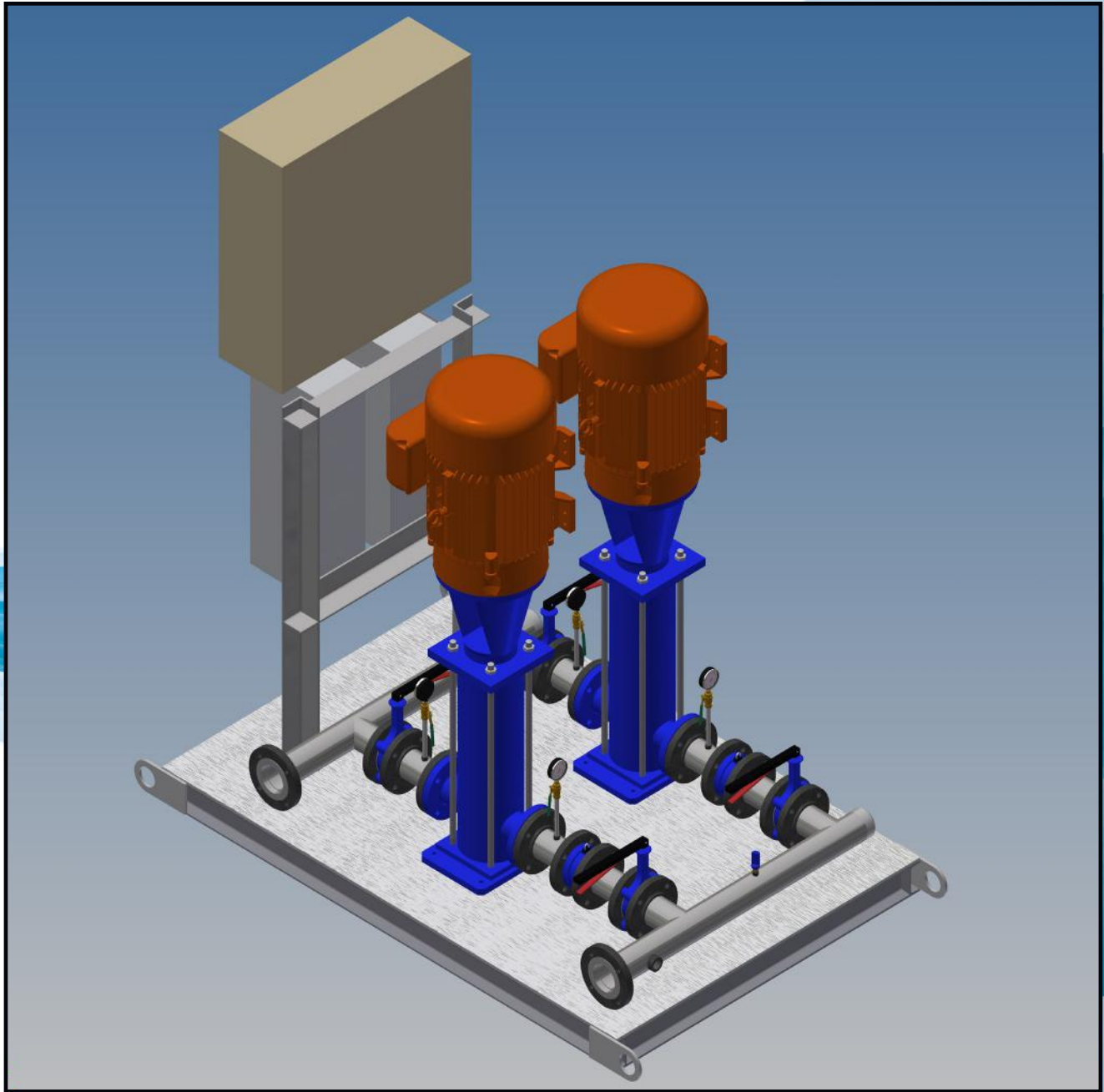

We are proud supplier for the following
completed and on going projects :



250 West Street
250 W St, Redmond, Utah
84652, United States



John Deere,
2624 Old U.S. 169,
Coffeyville, KS 67337, USA



Le Séville
2183 Ste-Catherine O.
Street,
Montreal, QC H3H 1M9



Havre du Ruisseau
155, Chevigny Place
Sainte-Therese (Quebec)
J7E 0A1

Sales and Service:

Quebec, Canada
Tel. : (450) 621-2995
Fax : (450) 621-4995

Lake Worth
Florida, USA
33467-5749

Toronto, Canada
Tel. : +1 (647) 544-2995

www.flofab.com

SERVICE 24/7 : parts@flofab.com

