

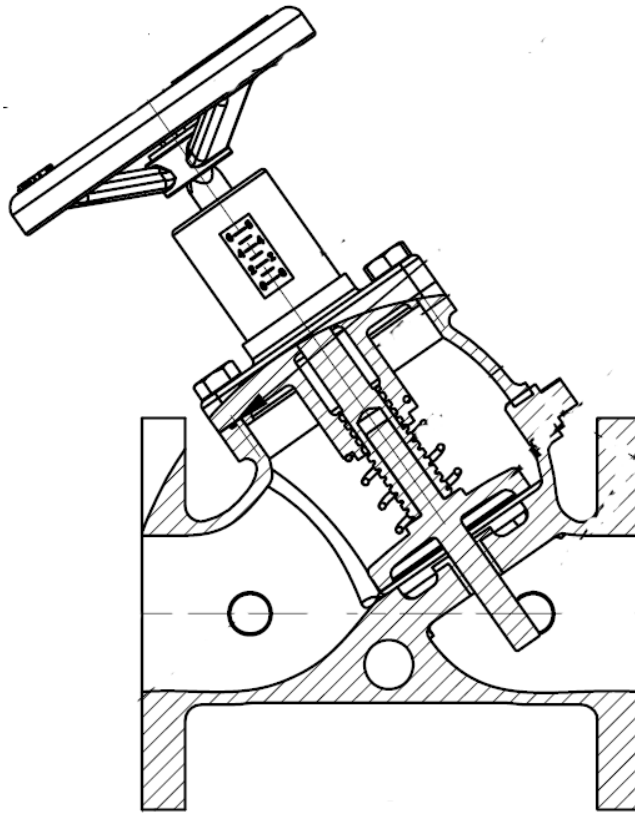

TRIPLE DUTY CHECK VALVE

MFV

Installation and Operating Instructions





INTRODUCTION

The FV38 Triple Duty Check Valve combination valves are designed for installation on the discharge side of centrifugal pumps, the combination valve incorporates three functions in one valve:

- ◆ Drip-tight, shut-off valve;
- ◆ Spring closure design: Non-slam check valve;
- ◆ Flow throttling valve;

INSTALLATION

Determine the system flow requirements. Refer to pressure drop charts and select a valve whose flow rate of 50% is closer to this figure.

Install valve in the direction of the flow arrows on the valve body. 5-10 pipe diameters from the discharge of the pump.

OPERATION

1. Turn handwheel counter clockwise until indicator reads in the 100% open position.
2. Start system pump, and purge all air from system.
3. Install test plugs or pressure gauges in the two ports on the inlet and outlet of the valve and read the differential pressure across the valve. Pressure drop across the valve should not exceed 11 psi. Excessive noise or damage to the valve may occur on the pressure drop above 11 psi.
4. Refer to the appropriate performance curve or Cv chart to locate flow based on the results from “3” and the “percent open” as indicated.
5. Slow close the valve, turning handwheel clockwise until the certain GPM flow rate is achieved. Relock or remove the handwheel to ensure this setting.
6. Consult pump manufacturers guideline if contain GPM is achieved with the valve at <50% open, pump impeller may need to be trimmed.

MAINTENANCE

Please use the correct tool at room temperature when maintaining the triple duty check valve. Contact your nearest representative for any replacements accessories.

