

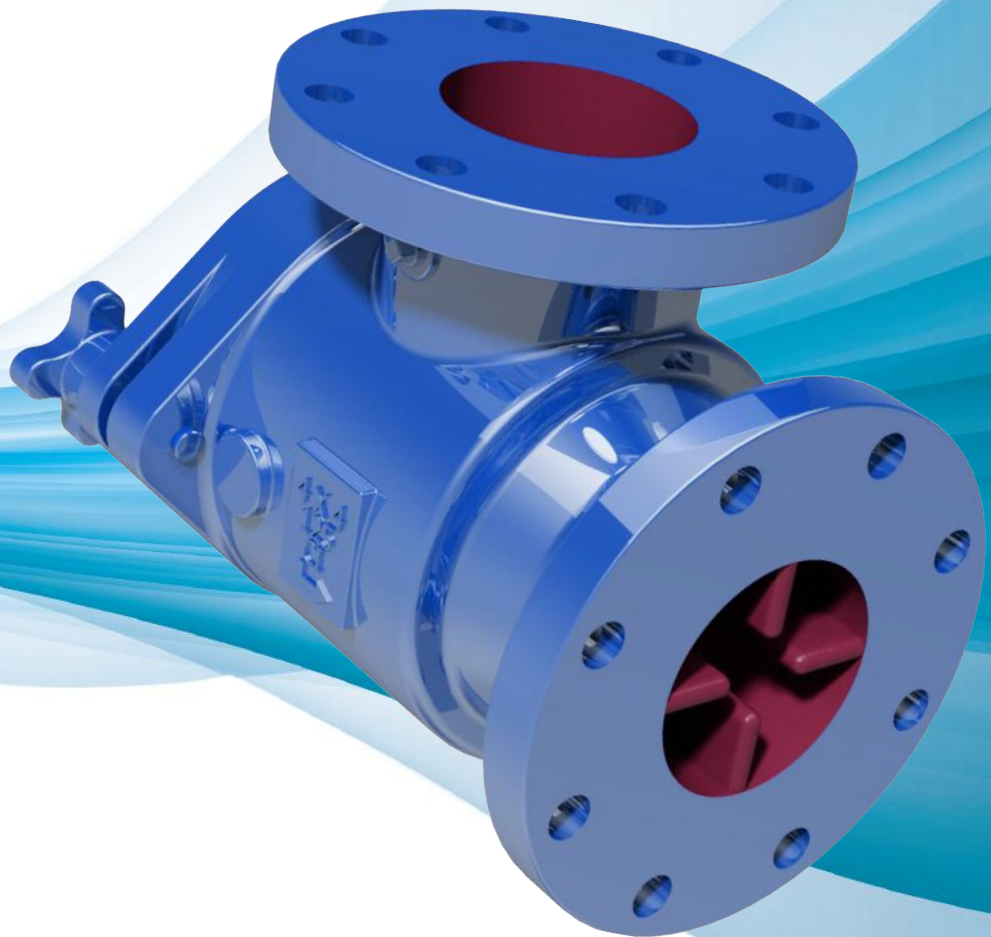

Suction Diffuser

ASDFF



www.flofab.com

001-cat-2016-asdff

Go to www.flofab.com in Our Products Section to see the Master Spec - <http://www.arcomnet.com/masterspec/>

TABLE OF CONTENTS

FEATURES.....	2
MESURES GRID - CAST IRON CONSTRUCTION.....	3
MESURES GRID - STEEL FABRICATED.....	4-5
TYPICAL INSTALLATION.....	6
PRESSURE DROP VS FLOW RATE.....	7-8

HISTORY

Flo Fab was established in 1981 by Denis Gauvreau who created and developed the products line and constantly being perfected by Marc Gauvreau, as well as by a team of professional engineers and designers. It's a combination of existing designs from several renowned products and the innovative ideas of a new generation professionals.

Through the years, Flo Fab has acquired several companies and service entities including : AQUA-PROFAB (ASME Tanks manufacturer), MÉNARD, LÉONARD ÉLECTRIQUE, PMA. , Furthermore Flo Fab purchased equipment, fabrication designs and patterns from IDEALCO, a manufacturer of shell and tube type heat exchangers.

The after sales services, sales, engineering, R&D, production, quality control, accounting and administration departments of all the above companies share the same location.

In December 2014, Marc Gauvreau, son of the founder, acquired all shares of The company. Flo Fab and is constantly investing in new state of the art innovations new product like the XRI series and Prefab Skid for Hydronic Heating & cooling system, pumping systems. This has allowed Flo Fab to retain competent and experienced staff of professionals with varied and specialized abilities that constantly work on improving our existing products and add new engineered solutions that exceeding customer's expectations .

Flo Fab has grown quite rapidly and now proudly offers of a wide range of products available directly from one manufacturer. This includes pumps & pump packages, tanks, heat exchangers & hydronic accessories. This allows each project stakeholders to enjoy economical savings, peace of mind, best value for their investment and optimized total cost of ownership.





• Suction Diffusers Series ASDFF «Cast Iron Construction»

• Features

The FLO FAB suction diffusers are designed to reduce space and installation cost by replacing a long radius elbow, Y strainer and extended entry pipe on the suction side of the pump. The flow stabilizing vane reduces turbulence and prevents stress and vibration.

In addition, the suction diffuser strainer removes foreign particles which may be hazardous for the pump and other system equipment. FLO FAB suction diffusers are available in a variety of materials recommendation based on the flow media.

- Directly mounted in horizontal position.
- Flanges are class 175 ANSI (ASA) flat faced (Class 250 also available)
- Integrally cast stabilizing vanes.
- Separate fine mesh start-up screen surround the perforated screen
- Cast on pads for convenient mounting of standard I.D. support foot.
- Pressure taps available on all sizes

Sizes: From 2" to 20" (50 mm to 500 mm)

Body: Cast iron /Fabricated Steel Also Available

Connections: Flange x Flange

Flange Ratings:

Class 150

175 PSI (120658 kPa) at 250°F (121 .1°C)

Class 250:

400 PSI (2757.90 kPa) at 150°F (65.56°C)

Pressure: Class125

Working Pressure: 200 PSI

Working Temp: NBR -12°C~+82°C
-53.6°F~+179.6°F

EPDM -35°C~+135°C
-95°F~+275°F

Medium: W. O. G.

Shell Test: 2.07 Mpa

Flange: ASME/ANSI, B16.1, C125

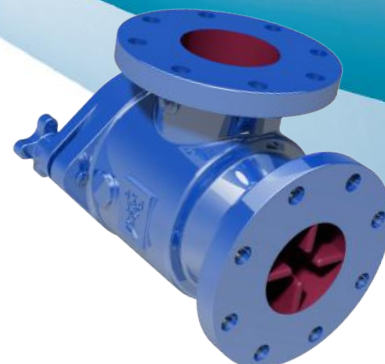



Suction Diffusers Series ASDFF
«Cast Iron Construction»

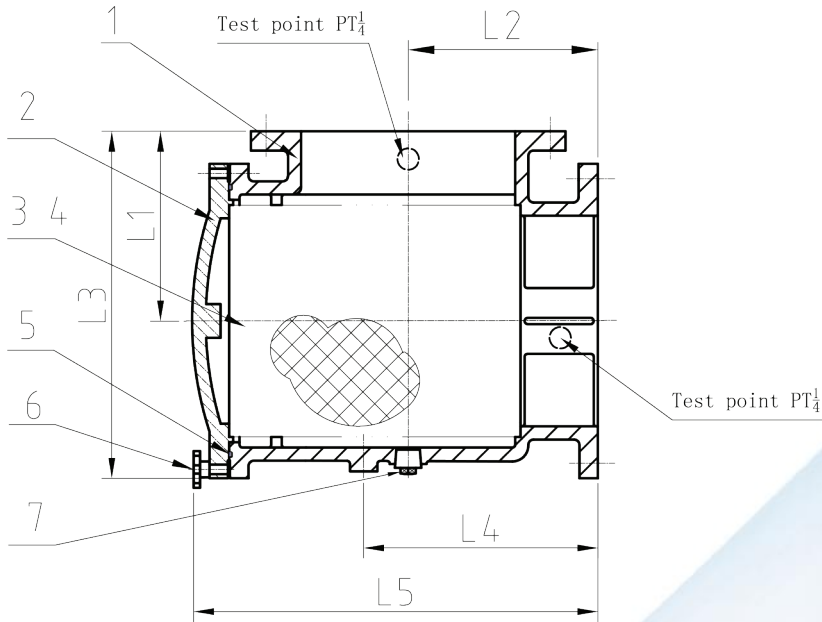

1	Body	150CI/250DI
2	Cover	150CI/250DI
3	Perforated Screen	SS304
4	Wire Woven Screen	SS304
5	O-Ring	NBR/EPDM
6	Knob, Bolt	WCB
7	Plug	WCB

√	Size	Dimensions (in/mm)										NPT
		L1 (in)	L1 (mm)	L2 (in)	L2 (mm)	L3 (in)	L3 (mm)	L4 (in)	L4 (mm)	L5 (in)	L5 (mm)	
	2x2	4.5	114.3	4.5	114.3	6.65	169	5.94	151	9.96	253	19.05mm 0.75"
	2.5x2	5	127	5	127	7.52	191	6.57	167	10.63	270	
	2.5x2.5			4.5	114.3	7.68	195	6.04	153.6	9.92	252	
	3x2	5.5	139.7	5.5	139.7	8.50	216	7.04	179	11.18	284	
	3x2.5			5.5	139.7	8.50	216	7.04	179	11.18	284	
	3x3	6.5	165	6.5	165	10.35	263	8.77	223	13.15	334	25.4mm 1"
	4x3					10.24	260	8.27	210	12.91	328	
	4x4	7.5	190.5	7.5	190.5	13.07	332	10	254	15.51	394	
	5x4					13.07	332	10	254	15.51	394	
	5x5	7.99	203	7.99	203	14.45	367	10.70	272	16.65	423	
	6x4			7.99	203	14.45	367	10.70	272	16.65	423	
	6x5	7.56	192	9	228.6	13.11	333	12.95	329	19.17	487	31.75mm 1.25"
	6x6			9	228.6	13.11	333	12.95	329	19.17	487	
	8x5	9	228.6	8	203.2	15.47	393	11.69	297	17.91	455	
	8x6			8	203.2	15.47	393	11.69	297	17.91	455	
	8x8	11	279.4	9	228.6	17.24	438	11.61	295	21.34	542	
	10x8					19.21	488			21.22	539	
	10x10	11.2	280	11	279.4	20.75	527	14.17	360	26.69	678	31.75mm 1.25"
	12x8			11	279.4	20.75	527	14.17	360	26.69	678	
	12x10	12	304.8	11	279.4	21.78	553	14.17	360	26.69	678	
	12x12			12	304.8			21.78	553			

NOTE: LARGER SIZE UP TO 20" AVAILABLE

● Suction Diffusers Series ASDFF «Steel Fabricated»

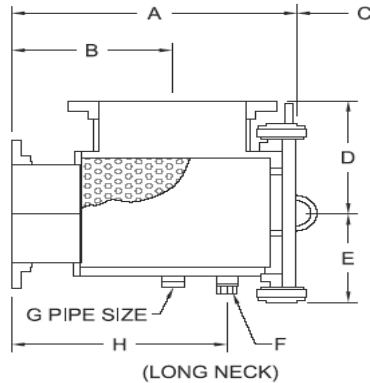

1	Body	Cast Iron A126-B
2	Cover	Cast Iron A126-B
3	Strainers	Stainless Steel
4	Start-Up	20 Mesh Screen
5	Diffuser	Cast Iron A126-B
6	Gasket	BUNA-N
7	O'ring	BUNA-N
8	Purge	Steel

✓	SIZE		A in/mm	B in/mm	C in/mm (1)	D in/mm	E in/mm	F in/mm	G in/mm	H in/mm	Weight lb./kg.	Measure
	INLET	OUTLET										
	10 250	8 200	24.63 626	14.25 362	16.75 425	12.63 321	9.50 241	1 25	1 25	18.38 467	339 154	INCHES mm
	10 250	10 250	25.50 648	14.88 378	17.00 432	13.63 346	10.50 267	1 25	1 25	19.13 486	420 191	INCHES mm
	12 300	8 200	27.88 708	15.25 387	18.75 476	12.88 327	9.50 241	1-1/2 40	1-1/2 40	19.88 505	437 198	INCHES mm
	12 300	10 250	27.50 699	16.00 406	18.88 479	13.88 353	10.50 267	1-1/2 40	1-1/2 40	20.75 527	530 240	INCHES mm
	12 300	12 300	28.13 714	16.25 413	19.25 489	15.13 384	11.75 298	1-1/2 40	1-1/2 40	21.13 537	650 295	INCHES mm
	14 350	10 250	28.75 730	16.63 422	20.13 511	14.00 356	10.50 267	1-1/2 40	1-1/2 40	21.63 549	670 304	INCHES mm
	14 350	12 300	31.13 791	18.38 467	20.50 521	16.00 406	11.75 298	1-1/2 40	1-1/2 40	22.13 562	808 367	INCHES mm
	14 350	14 350	31.13 791	18.38 467	20.75 527	16.00 406	12.50 318	1-1/2 40	1-1/2 40	22.88 581	964 437	INCHES mm
	16 400	12 300	31.75 806	18.00 457	22.50 572	16.50 419	11.75 298	2 50	2 50	23.75 603	913 414	INCHES mm
	16 400	14 350	32.25 819	18.50 470	22.75 578	16.25 413	12.50 318	2 50	2 50	27.38 619	1089 493	INCHES mm
	16 400	16 400	33.13 842	19.00 483	22.13 588	17.50 445	13.75 349	2 50	2 50	25.00 635	1280 581	INCHES mm
	18 450	14 350	35.38 898	19.58 498	23.00 584	17.63 448	12.50 318	2 50	2 50	26.00 660	1058 480	INCHES mm
	18 450	16 400	35.25 895	20.13 511	25.13 638	17.63 448	13.75 349	2 50	2 50	26.63 676	1256 569	INCHES mm
	18 450	18 450	36.38 924	20.75 727	25.63 651	19.88 505	16.00 406	2 50	2 50	27.50 699	1572 713	INCHES mm
	20 500	16 400	37.25 946	21.13 537	27.13 689	20.13 511	13.75 349	2 50	2 50	28.13 715	1452 659	INCHES mm
	20 500	18 450	38.50 978	21.88 556	27.63 702	20.13 511	16.00 406	2 50	2 50	29.13 740	1793 813	INCHES mm
	20 500	20 500	42.13 1070	22.25 565	30.88 784	23.50 597	19.38 492	2 50	2 50	31.13 791	2560 1161	INCHES mm
	24 600	18 450	42.63 1083	24.00 610	31.63 703	20.50 521	16.00 406	2 5	2 5	32.25 819	2382 1080	INCHES mm
	24 600	20 500	46.25 1175	24.38 619	34.88 886	23.88 607	19.38 492	2 50	2 50	34.25 870	3545 1608	INCHES mm
	24 600	24 600	47.38 1203	25.50 648	34.88 886	23.88 607	19.38 492	2 50	2 50	35.38 899	3600 1633	INCHES mm

• Suction Diffusers Series ASDFF «Steel Fabricated»

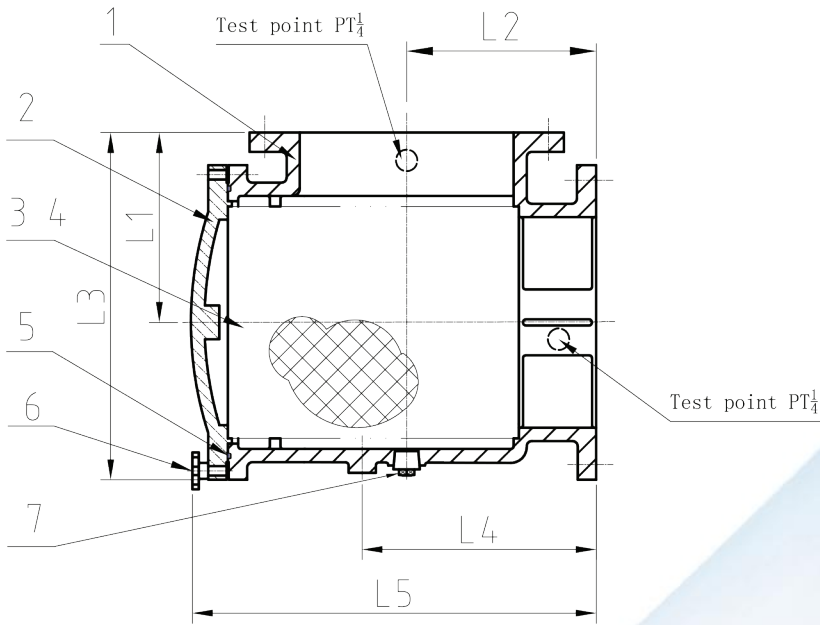

1	Body	Cast Iron A126-B
2	Cover	Cast Iron A126-B
3	Strainers	Stainless Steel
4	Start-Up	20 Mesh Screen
5	Diffuser	Cast Iron A126-B
6	Gasket	BUNA-N
7	O'ring	BUNA-N
8	Purge	Steel

√	Size	L1		L2		L3		L4		L5		NPT
		(in)	(mm)	(in)	(mm)	(in)	(mm)	(in)	(mm)	(in)	(mm)	
	2x2	4.5	114.3	4.5	114.3	6.65	169	5.94	151	9.96	253	19.05mm 0.75"
	2.5x2	5	127	5	127	7.52	191	6.57	167	10.63	270	
	2.5x2.5											
	3x2	5.5	139.7	4.5	114.3	7.68	195	6.04	153.6	9.92	252	
	3x2.5			5.5	139.7	8.50	216	7.04	179	11.18	284	
	3x3											
	4x3	6.5	165	6.5	165	10.35	263	8.77	223	13.15	334	25.4mm 1"
	4x4					10.24	260	8.27	210	12.91	328	
	5x4	7.5	190.5	7.5	190.5	13.07	332	10	254	15.51	394	
	5x5											
	6x4	7.99	203	6.50	165	12.95	329	8.78	223	13.58	345	
	6x5			7.99	203	14.45	367	10.70	272	16.65	423	
	6x6											
	8x5	7.56	192	9	228.6	13.11	333	12.95	329	19.17	487	31.75mm 1.25"
	8x6	9	228.6	8	203.2	15.47	393	11.69	297	17.91	455	
	8x8			9	228.6	17.24	438	11.61	295	21.34	542	

• **Suction Diffusers Series ASDFF**
Piping Details

TYPICAL INSTALLATION

FRAME MOUNTED

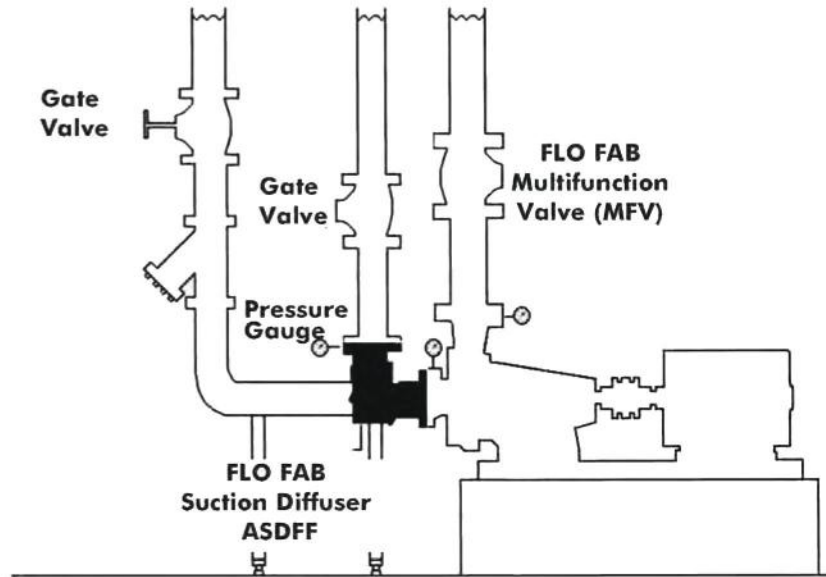

IN-LINE

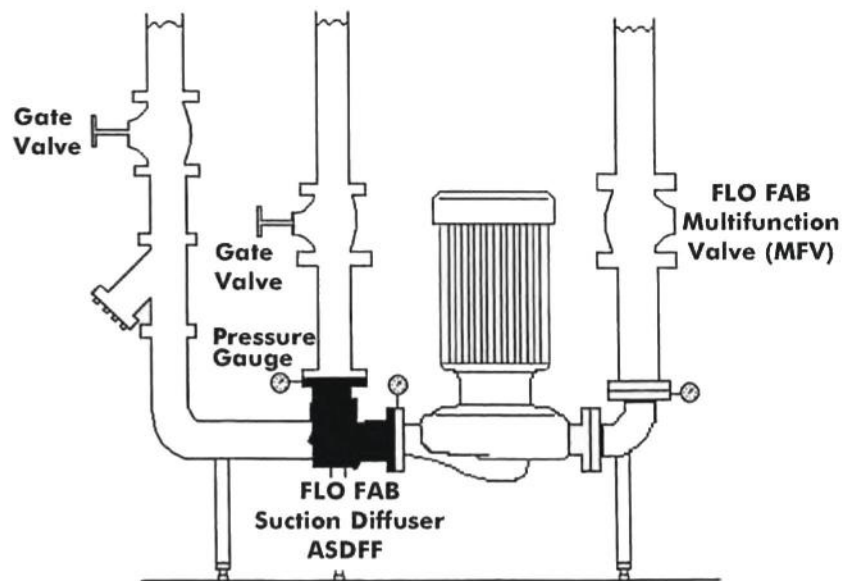



● Pressure Drop VS Flow Rate

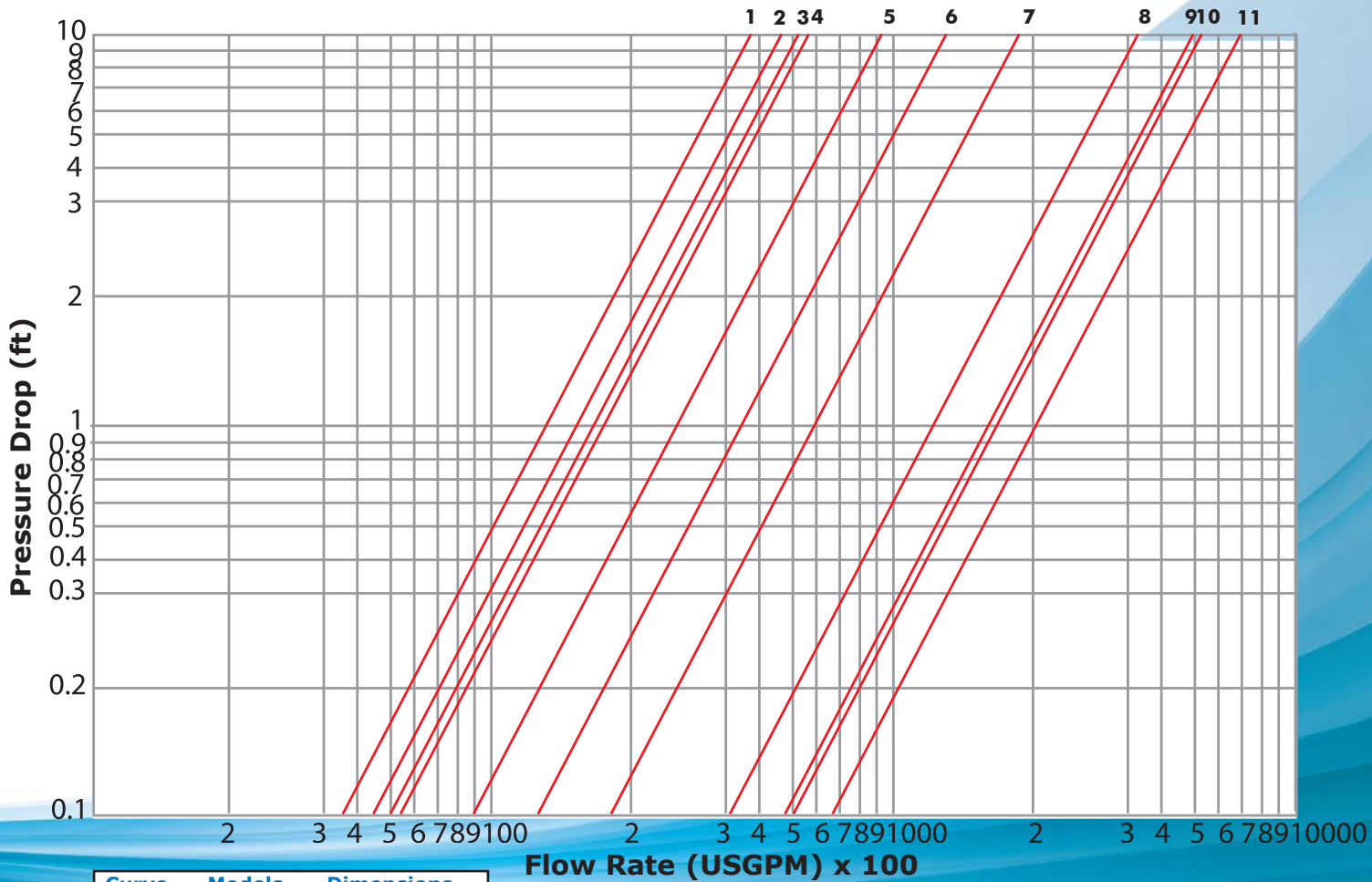

Curve	Models	Dimensions
1	ASDFF0202 ASDFF0325	2 x 2 3 x 2.5
2	ASDFF2502	2.5 x 2
3	ASDFF0302 ASDFF0303 ASDFF0403	3 x 2 3 x 3 4 x 3
4	ASDFF2525	2.5 x 2.5
5	ASDFF0404 ASDFF0504 ASDFF0604	4 x 4 5 x 4 6 x 4
6	ASDFF0505 ASDFF0605	5 x 5 6 x 5
7	ASDFF0606 ASDFF0806	6 x 6 8 x 6
8	ASDFF0808 ASDFF1008	8 x 8 10 x 8
9	ASDFF1010	10 x 10
10	ASDFF1210	12 x 10
11	ASDFF1212	12 x 12

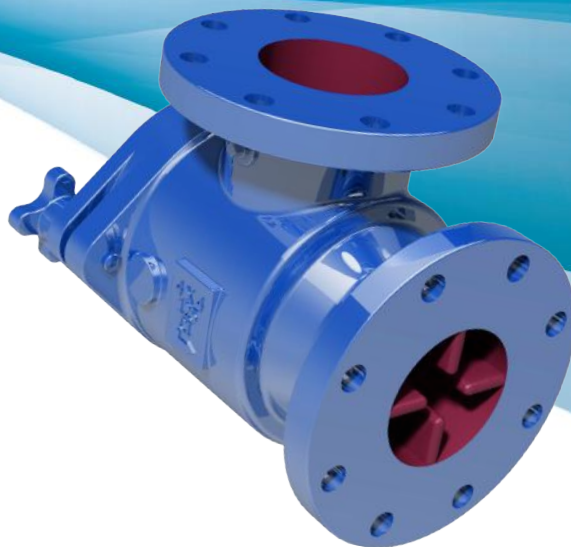



● Pressure Drop vs Flow Rate

Water Service, Clean Basket, 1/32" - 1/4"
Perforated Screen

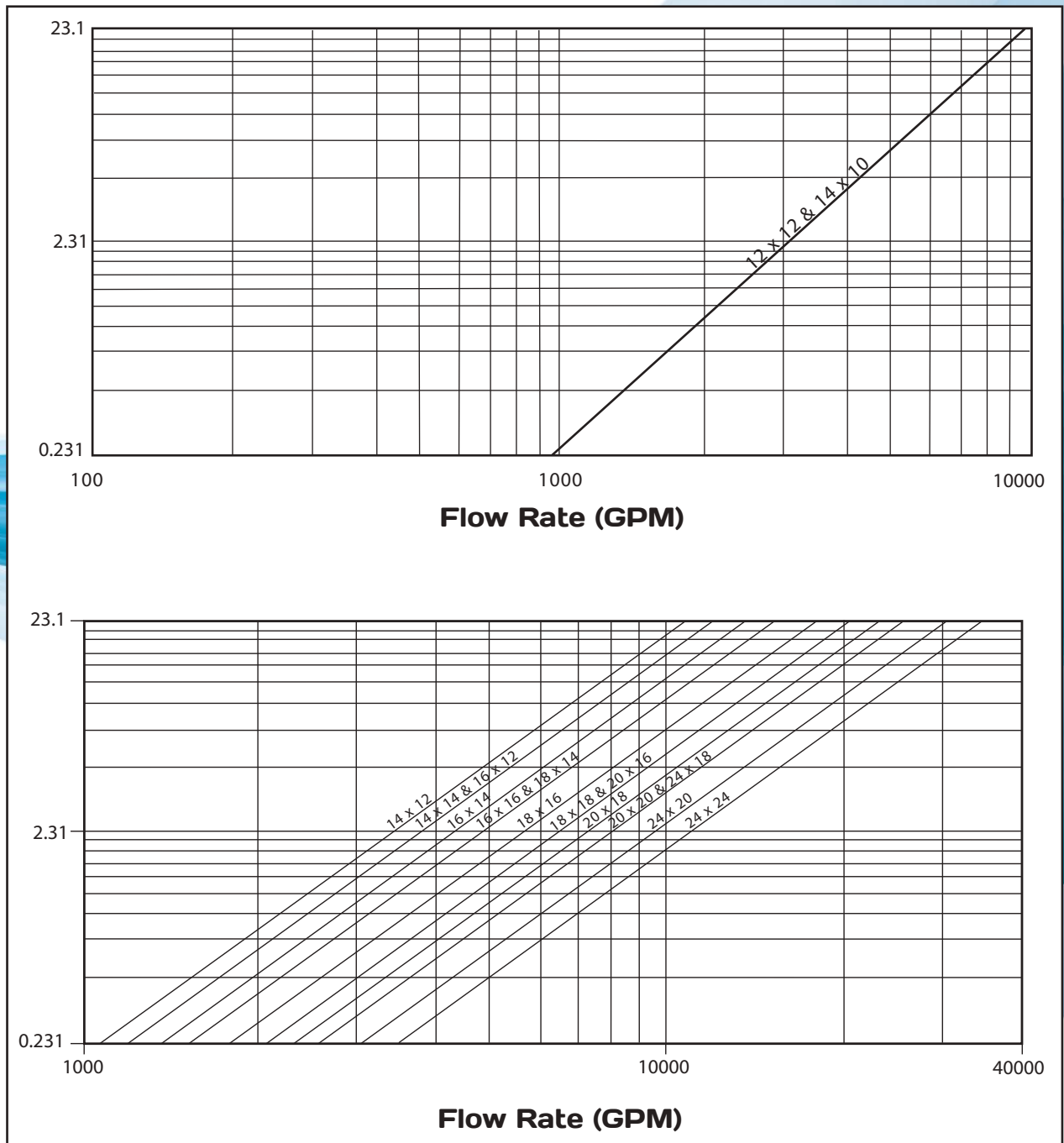

- **Other System**

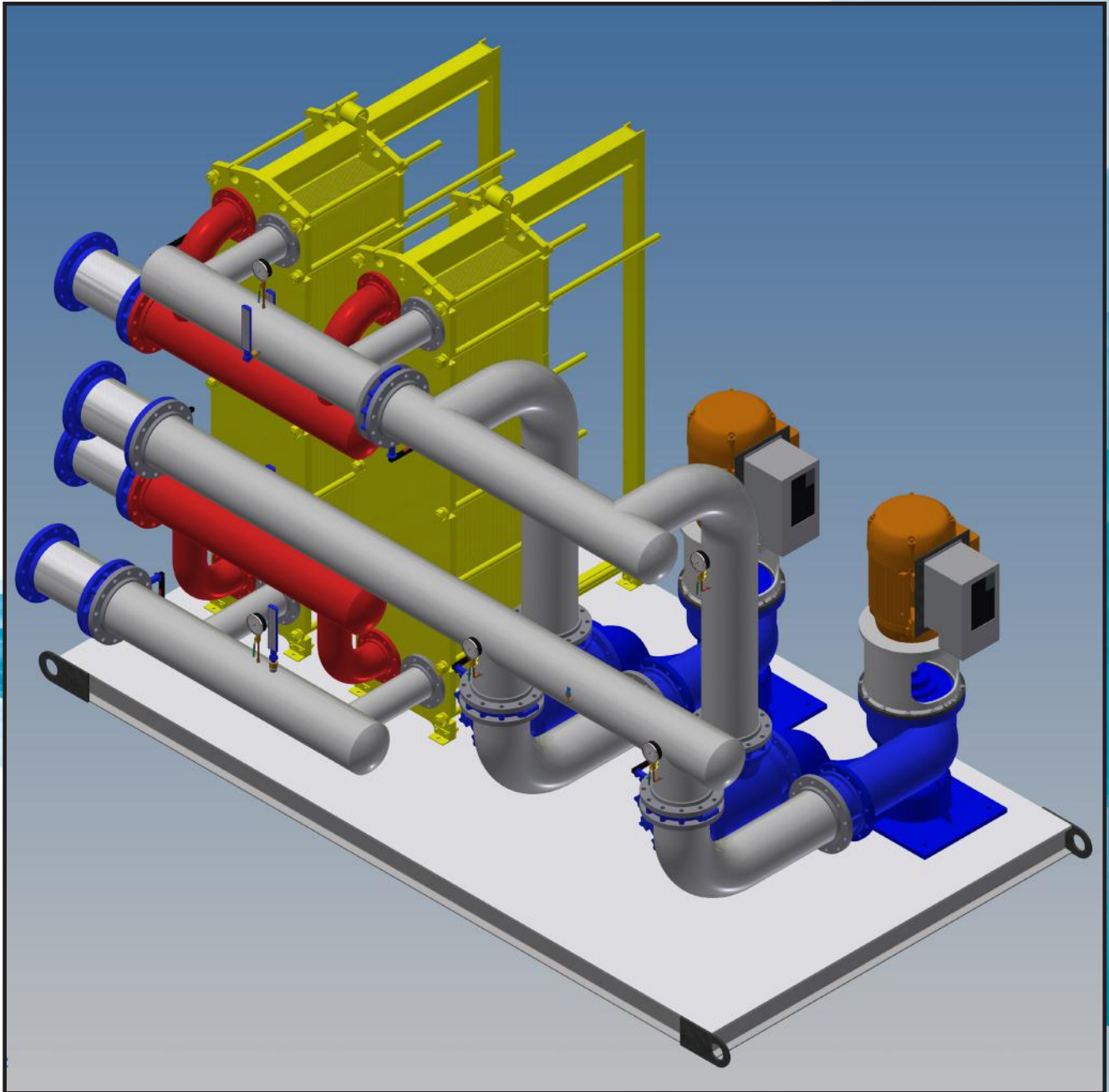

- **Other System**

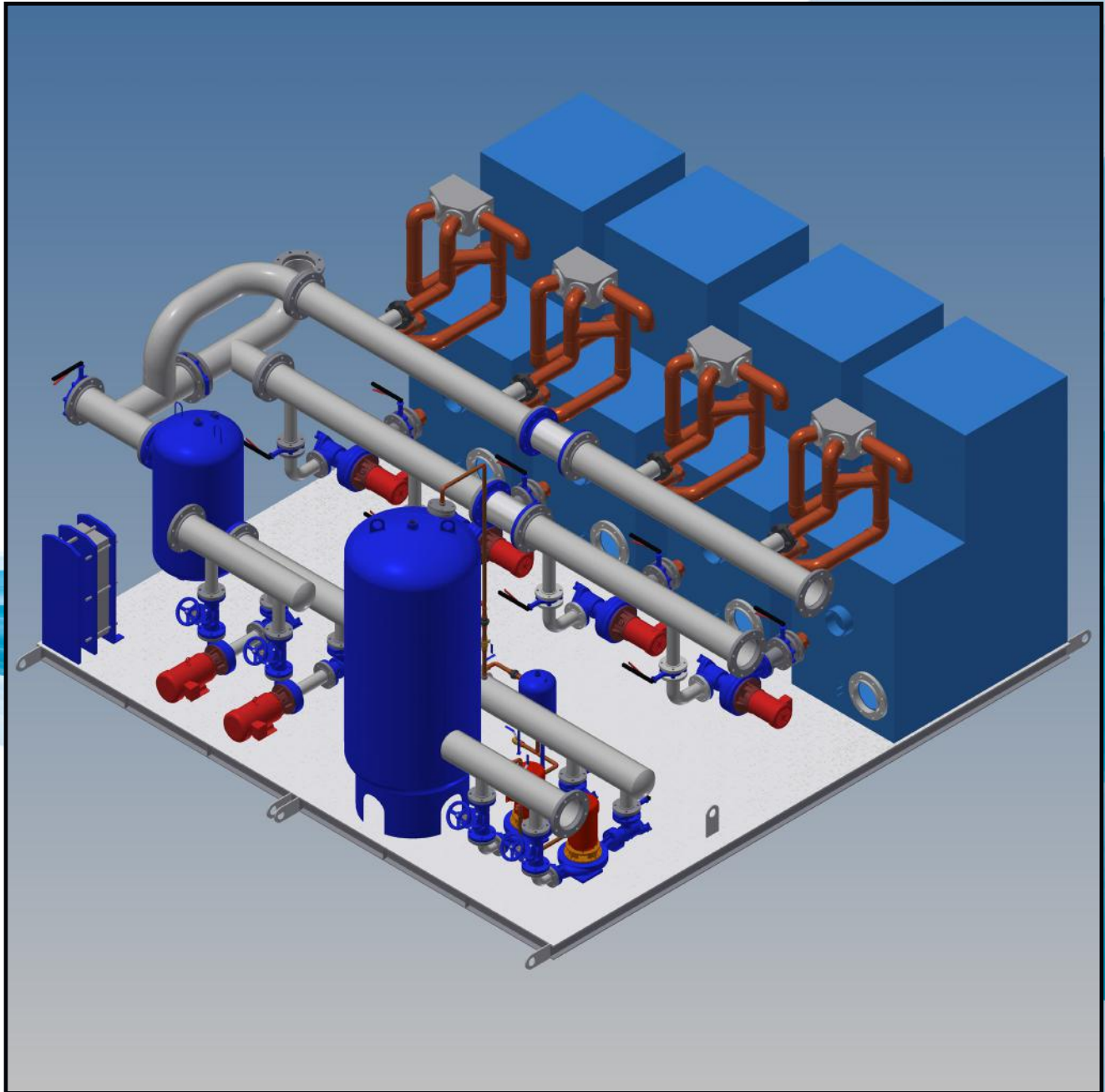

We are proud supplier for the following completed and on going projects :



Rogers Arena
800 Griffiths Way,
Vancouver, BC V6B 6G1



Hoffs Bakery,
1 Brainard Ave, Medford,
MA 02155, United States



Trigone Ste-Therese
305 Curé-Labelle, Boul.
Sainte-Therese,
QC J7E 2X8



Rimouski Hospital
150, Rouleau Avenue,
Rimouski, QC G5L 5T1

Sales and Service:

Quebec, Canada
Tel. : (450) 621-2995
Fax : (450) 621-4995

Lake Worth
Florida, USA
33467-5749

Toronto, Canada
Tel. : +1 (647) 544-2995

www.flofab.com

SERVICE 24/7 : parts@flofab.com

