



Multiple Accessories

Butterfly Valve

BFVZ

Wafer Check Valve

LSDDB

Flexible Connectors

ST-SM-SSP-DSP-DUT

Y and Basket Strainers

LCTY-LYF-SBS-DBS



www.flofab.com

TABLE OF CONTENTS

VALVE STYLE BUTTERFLY - BFVZ.....	2
VALVE STYLE BUTTERFLY - BFVZ : CHART.....	3-4
CV VALUE OF CONCENTRIC BUTTERFLY VALVES.....	5
WAFER CHECK VALVE - LSDDDB : CHART.....	6
SILENT CHECK VALVE ENGINEERING DATA.....	7
STAINLESS STEEL FLEXIBLE SERIES - ST & SM.....	8
STAINLESS STEEL FLEXIBLE SERIES - ST : CHART.....	9
STAINLESS STEEL FLEXIBLE SERIES - SM : CHART.....	10
STAINLESS STEEL FLEXIBLE SERIES - SMF.....	10
EPDM UNION ARCH FLEXIBLES SERIES : DUT.....	11
EPDM UNION ARCH FLEXIBLES SERIES : SSP & DSP.....	12
EPDM UNION ARCH FLEXIBLES SERIES : SSP.....	13
EPDM UNION ARCH FLEXIBLES SERIES : DSP.....	14
EPDM UNION ARCH FLEXIBLES SERIES : SSP & DSP SPECS.....	15
THREADED Y STRAINER SERIES - LCTY & LYF.....	16
THREADED Y STRAINER SERIES - LCTY : CHART.....	17
THREADED Y STRAINER SERIES - LYF : CHART.....	18
FLANGED BASKET STRAINER SERIES - SBS & DBS.....	19
SIMPLE BASKET STRAINER SERIES - SBS : CHART.....	20
DUPLEX BASKET STRAINER SERIES - DBS : CHART.....	21
REPLACEMENT SCREEN & BASKET - SBS & DBS.....	22
STRAINERS PRESSURE DROP CURVES.....	23



2' to 6' BFVZ Style Butterfly & 8' to 14' BFVZ Style Butterfly

(See chart on page 3)



Body: Ductile Iron

Disc Body: Ductile Iron

Disc: DI nickle plated/DI Nylon coated/CF8/CF8M/
Bronze/Hastert Nickle Alloy/1.4529(Duplex
stainless stee.)

Seat: NBR /EPDM /PTFE /VITTON

Shaft: SS410/SS316

Lever: Ductile Iron/Aluminium Alloy

Work temperature: -12°C~100°C(NBR)/-20°C~130°C(EPD-
M)/-10°C~180°C(PTFE)/ -20°C~220°C(VITON)

Flange standard: GB/T 9113, JB/T 79, BS4504,DIN, ANSI
B16.5, ANSI B16.1 DI nickle plated/DI Nylon coated/CF8/CF8M/
Bronze/Hastert Nickle Alloy/1.4529(Duplex stainless stee.)

Maximum Working Pressure :

from 2" (50mm) to 12" (300mm)

200 PSI PN16 (1376 kPa) @ 225°F (107°C)

From 14" (350mm) to 24" (600mm)

150PSI PN10 (1034 kPa) @ 225°F (107°C)

BFVZ // Lugged butterfly valve, lever operated

(See chart on page 4)



Body: Ductile Iron

Disc: DI nickle plated/DI Nylon coated/CF8/CF8M/
Bronze/Hastert Nickle Alloy/1.4529(Duplex
stainless stee.)

Seat: NBR /EPDM /PTFE /VITTON

Shaft: SS410/SS316

Lever: Ductile Iron/Aluminium Alloy

Work temperature: -12°C~100°C(NBR)/-20°C~130°C(EPD-
M)/-10°C~180°C(PTFE)/ -20°C~220°C(VITON)

Flange standard: GB/T 9113, JB/T 79, BS4504,DIN,ANSI
B16.5, ANSI B16.1

Maximum Working Pressure :

from 2" (50mm) to 12" (300mm)

200 PSI PN16 (1376 kPa) @ 225°F (107°C)

From 14" (350mm) to 24" (600mm)

150PSI PN10 (1034 kPa) @ 225°F (107°C)

BFVZ // Gearbox operate Lug type butterfly valve

FLO FAB'S BUTTERFLY VALVES SERIES - BFVZ

• 2' to 6' BFVZ Style Butterfly

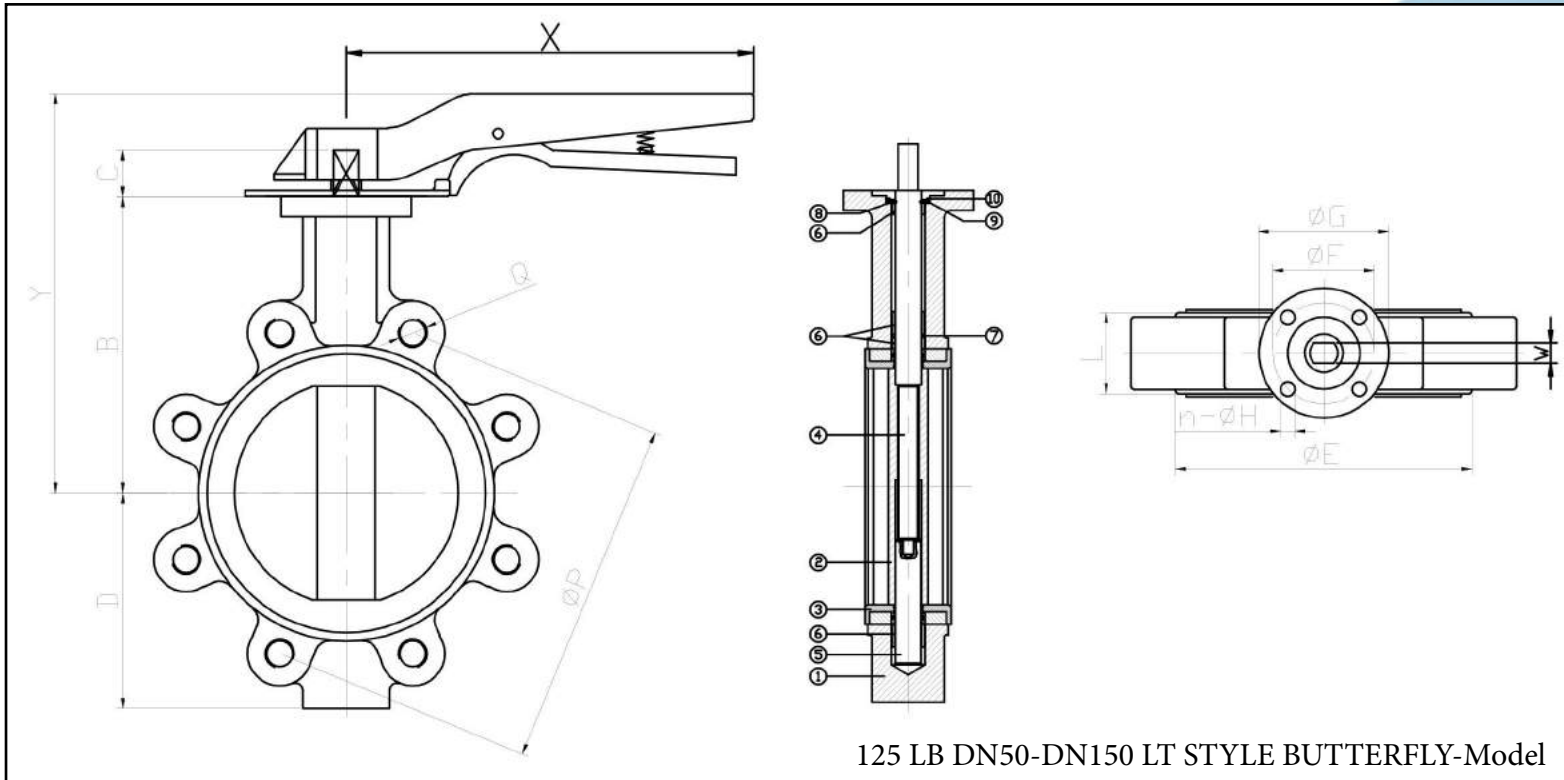

125 LB DN50-DN150 LT STYLE BUTTERFLY-Model

Dimensions (in)																	
MODEL	SIZE	DN	A	B	C	D	E	F	G	nx Ø H		L	M	P	Q	X	Y
BFV0200-L	2"	1.97	2.07	5.59	1.25	3.15	3.78	2.76	3.54	4x Ø 10	F7	1.69	0.35	4.75	4-5/8UNC	9.89	6.85
BFV0250-L	2.5"	2.56	2.54	6.10		3.50	4.57					1.81		5.5			7.36
BFV0300-L	3"	3.15	78.9	6.33		3.74	5.20					6		7.60			
BFV0400-L	4"	3.94	4.10	7.08		4.49	5.98					0.43	7.5	8-5/8UNC	8.35		
BFV0500-L	5"	4.92	4.86	7.60		5	7.17					0.55	8.5	8-3/4UNC	8.86		
BFV0600-L	6"	5.90	6.14	8.07		5.47	8.07					9.5	9.33				

Dimensions (mm)																	
MODEL	SIZE	DN	A	B	C	D	E	F	G	nx Ø H		L	M	P	Q	X	Y
BFV0200-L	2"	50	52.6	142	32	80	96	70	90	4x Ø 10	F7	43	9	120.65	4-5/8UNC	251.2	174
BFV0250-L	2.5"	65	64.4	155		89	116					46		139.7			187
BFV0300-L	3"	80	78.9	161		95	132					52		152.4			193
BFV0400-L	4"	100	104.1	180		114	152					11	190.5	8-5/8UNC	212		
BFV0500-L	5"	125	123.4	193		127	182					14	215.9	8-3/4UNC	225		
BFV0600-L	6"	150	155.96	205		139	205					241.3	237				

NO.	PARTS	DESCRIPTION
1	Body	Ductile Iron
2	Disc	CF8
3	Seat	EPDM/NBR
4	UpperShaft	SS410
5	LowerShaft	
6	Bush	Nylon
7	O-Ring	EPDM
8	Half Ring	SS
9	Washer	
10	Preventor	Spring Steel

Models & Dimensions	Rated Output USGPM	Max Output USGPM	Ratio
3Dc-15 2" - 6"	150	270	24:1
3Dc-50 8" - 10"	500	700	30:1
3Dc-120 12" - 14"	1000	1200	50:1

LARGER SIZE AVAILABLE UPON REQUEST*

Dimensions not to be used for construction unless prints certified by factory.

Dimensions are subject to change without prior notice.

FLO FAB'S BUTTERFLY VALVES SERIES - BFVZ

• 8' to 14' BFVZ Style Butterfly

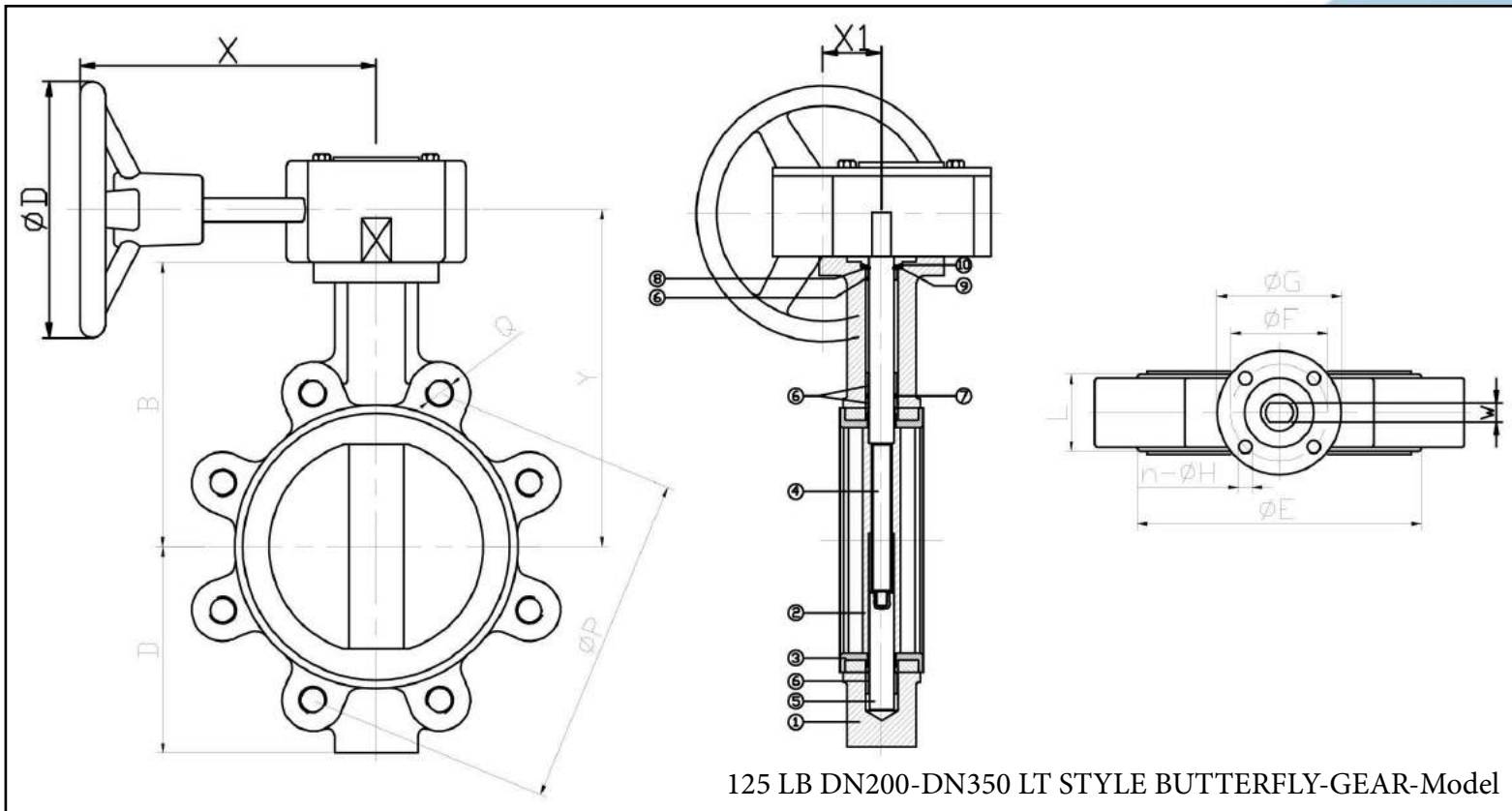

Dimensions (in)

MODEL	SIZE	DN	A	B	C	D	E	F	G	nx ϕ H		L	M	P	Q	X	X1	Y	D
BFV0800-L	8"	7.87	7.99	9.84	1.57	6.89	10.24	4.01	4.92	4x ϕ 12	F10	2.36	0.67	11.75	8-3/4UNC	8.74	2.99	11.18	8.46
BFV1000-L	10"	9.84	9.88	11.10		7.99	12.40					2.68	0.87	14.25	12-7/8UNC			12.44	
BFV1200-L	12"	11.81	11.89	12.83		9.53	14.60					3.07	17	18.75	12-1UNC			14.17	
BFV1400-L	14"	13.78	13.15	14.09		10.51	16.57												

Dimensions (mm)

MODEL	SIZE	DN	A	B	C	D	E	F	G	nx ϕ H		L	M	P	Q	X	X1	Y	D
BFV0800-L	8"	200	202.87	250	40	175	260	102	125	4x ϕ 12	F10	60	17	298.45	8-3/4UNC	222	76	284	215
BFV1000-L	10"	250	250.88	282		203	315					68	22	361.95	12-7/8UNC			316	
BFV1200-L	12"	300	301.9	326		242	371					78	431.8	12-1UNC	360				
BFV1400-L	14"	350	334.01	358		267	421							476.25					

Models & Dimensions	Rated Output USGPM	Max Output USGPM	Ratio
3Dc-15 2" - 6"	150	270	24:1
3Dc-50 8" - 10"	500	700	30:1
3Dc-120 12" - 14"	1000	1200	50:1

LARGER SIZE AVAILABLE UPON REQUEST*

Dimensions not to be used for construction unless prints certified by factory.

Dimensions are subject to change without prior notice.

NO.	PARTS	DESCRIPTION
1	Body	Ductile Iron
2	Disc	CF8
3	Seat	EPDM/NBR
4	UpperShaft	SS410
5	LowerShaft	
6	Bush	Nylon
7	O-Ring	EPDM
8	Half Ring	SS
9	Washer	
10	Preventor	Spring Steel

● CV Value of Concentric Butterfly Valves

Definition of a Kv Value

The value Kv is the flow rate of pure water at 15°C passing through the valve when the disc is fully opened and the differential pressure between the two ends of the valve is 100 kPa.

Definition of a Cv Value

The value Cv is the flow rate of pure water at 60°F passing through the valve when the disc is fully opened and the differential pressure between the two ends of the valve is 1 PSI.

Sizes in	Flow in USGPM @ 1 PSI @ Various Disc Angle								
	10°	20°	30°	40°	50°	60°	70°	80°	Full Open 90°
2	0.1	5	12	24	45	64	90	125	135
2½	0.2	8	20	37	65	98	144	204	220
3	0.3	12	22	39	70	116	183	275	302
4	0.5	17	36	78	139	230	364	546	600
5	0.8	29	61	133	237	392	620	930	1022
6	2	45	95	205	366	605	958	1437	1579
8	3	89	188	408	727	1202	1903	2854	3136
10	4	151	320	694	1237	2047	3240	4859	5340
12	5	234	495	1072	1911	3162	5005	7505	8250
14	6	338	715	1549	2761	4568	7230	10844	11917
16	8	464	983	2130	3797	6282	9942	14913	16388
18	11	615	1302	2822	5028	8320	13168	19752	21705
20	14	791	1674	3628	6465	10698	16931	25396	27908
24	22	1222	2587	5605	9989	16528	26157	39236	43116

$$Kv = Q \sqrt{\frac{G}{\Delta P}}$$

Q Maximum Flow (m³/h)
G Specific Gravity (g/cm³) (1 for water)
Δ P Differential Pressure (kPa)
Kv = 0.855 Cv

$$Cv = V \sqrt{\frac{G}{\Delta P}}$$

V Maximum Flow (USGPM)
G Specific Gravity (1 for water)
Δ P Differential Pressure (PSI)
Cv = 1.77 Kv

Dimensions not to be used for construction unless prints certified by factory.
 Dimensions are subject to change without prior notice.

● LSDDDB

NO.	PARTS	QTY	DESCRIPTION
1	Body	1	Cast Iron
2	Disc	2	AL-Bronze
3	Seat	1	EPDM
4	Shaft	2	SS316
5	Spring		
6	Plug	4	SS
7	Rubber Plug	4	Rubber
8	Gasket	4	PTFE

Dimensions (in)						
Size		A	B	C	D	E
2"	DN50	4.21	1.57	2.56	1.69	1.26
2.5"	DN65	5.00	2.36	3.15	1.81	1.30
3"	DN80	5.59	2.76	3.70	2.52	1.69
4"	DN100	6.38	3.46	4.61	2.52	1.85
5"	DN125	7.56	4.53	5.71	2.76	1.93
6"	DN150	8.66	5.28	6.69	2.99	2.01
8"	DN200	10.75	7.17	8.82	3.50	2.24
10"	DN250	12.91	8.66	10.43	4.49	3.03
12"	DN300	14.88	10.24	12.20	4.49	2.87
14"	DN350	17.24	11.73	14.17	5.00	3.07
16"	DN400	19.25	13.78	16.14	5.51	3.43

Dimensions (mm)						
Size		A	B	C	D	E
2"	DN50	107	40	65	43	32
2.5"	DN65	127	60	80	46	33
3"	DN80	142	70	94	64	43
4"	DN100	162	88	117	64	47
5"	DN125	192	115	145	70	49
6"	DN150	220	134	170	76	51
8"	DN200	273	182	224	89	57
10"	DN250	328	220	265	114	77
12"	DN300	378	260	310	114	73
14"	DN350	438	298	360	127	78
16"	DN400	489	350	410	140	87

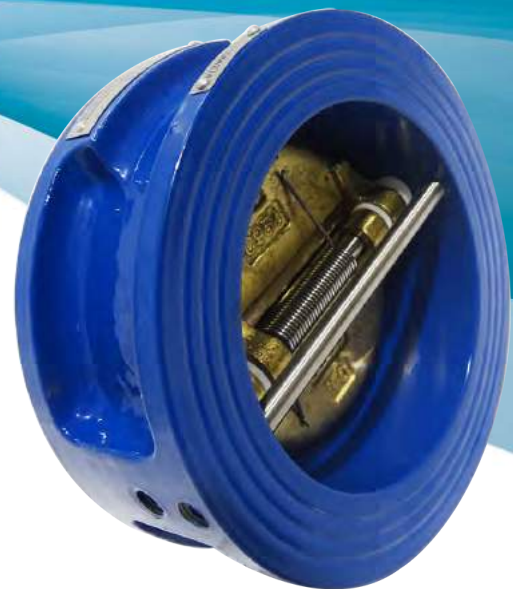
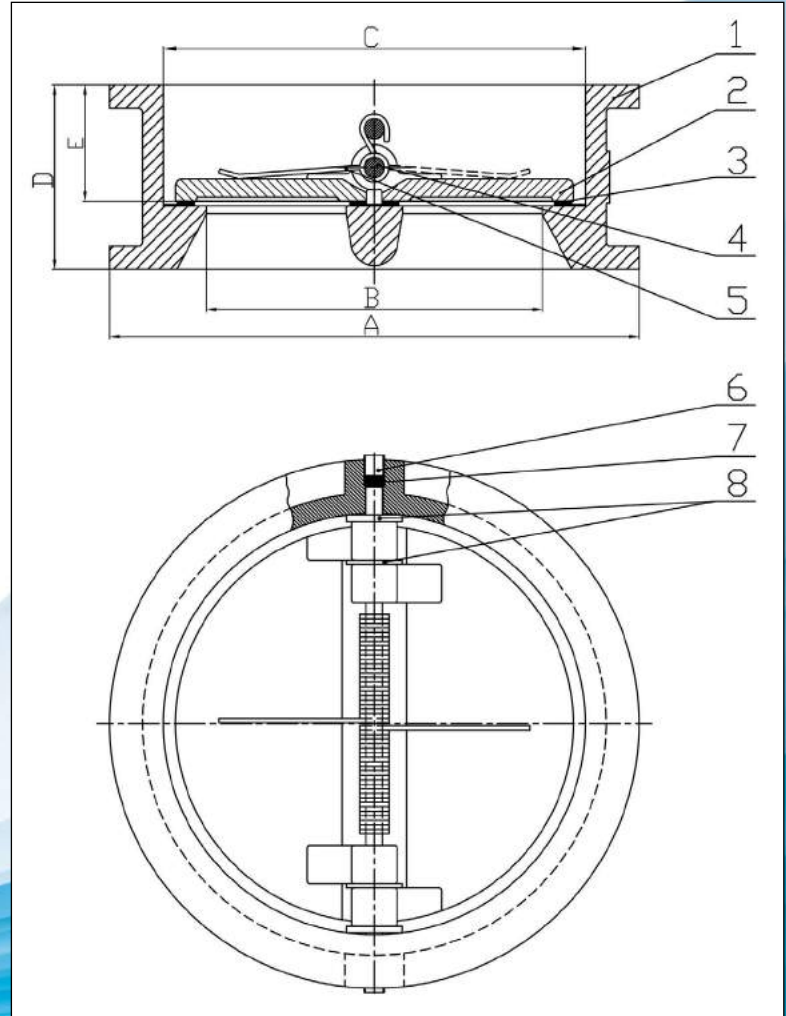

Dimensions not to be used for construction unless prints certified by factory. Dimensions are subject to change without prior notice.

Silent Check Valve Engineering Data

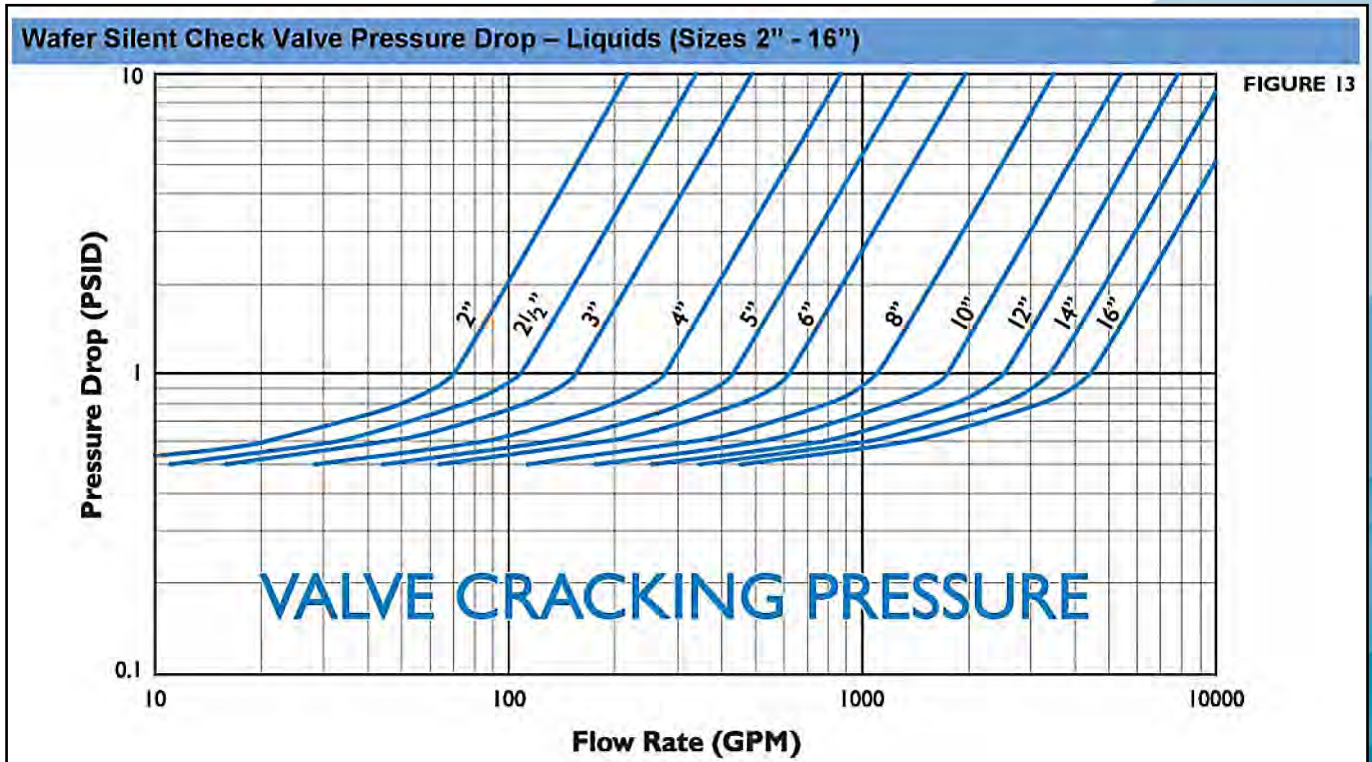

- Notes:**
1. Pressure drop curves are based on water flow.
 2. Valve cracking pressure is equal to or less than 0.5 psid.
 3. Valve cracking pressure increases to between 0.75 and 1.25 psid when installed vertically with flow upwards.

Method of Calculating Flow

Liquid Flow

$$C_v = Q \sqrt{\frac{G}{\Delta P}} \quad Q = C_v \sqrt{\frac{\Delta P}{G}} \quad \Delta P = G \left(\frac{Q}{C_v} \right)^2$$

Gas Flow

$$C_v = \frac{Q}{963} \sqrt{\frac{GT}{\Delta P (P_1 + P_2)}} \quad Q = 963 C_v \sqrt{\frac{\Delta P (P_1 + P_2)}{GT}}$$

Saturated Vapour

$$C_v = \frac{W}{K} \sqrt{\frac{1}{\Delta P (P_1 + P_2)}} \quad W = C_v K \sqrt{\Delta P (P_1 + P_2)}$$

Superheated Vapour

$$C_v = \frac{W(1+0.0007T_{sh})}{K} \sqrt{\frac{1}{\Delta P (P_1 + P_2)}} \quad C_v = \frac{C_v K}{(1+0.0007T_{sh})} \sqrt{\Delta P (P_1 + P_2)}$$

Variables

- | | |
|--|--|
| C_v = Valve Coefficient | Q = Flow |
| ΔP = $(P_1 - P_2)$ Pressure Drop | Liquid = USGPM |
| P_1 = Inlet Pressure (PSIA) | Gas = SCFH |
| P_2 = Outlet Pressure (PSIA) | T = Absolute Temperature ($^{\circ}F + 460$) |
| G = Specific Gravity | T_{sh} = Superheat ($^{\circ}F$) |
| Water = 1.0 at 60 $^{\circ}F$ and 1 ATM | Total Temperature Minus Saturation Temperature |
| Air = 1.0 at 60 $^{\circ}F$ and 1 ATM | W = lbs. Per Hour (LB/H) |
| | K = Constant For Vapours |

● ST & SM

(See chart on page 9)



Body: Stainless steel single braided corrugated hose with SCH40 carbon steel male nipples welded at each end.

Sizes: From 1/2" to 2" (15mm to 50mm)

Lengths: From 10" to 14" (250mm to 350mm)
other lengths also available.

Braided Hose: Gives a high temperature leak proof, with appropriate fittings attached you have a connector which allows temperature up to 850°F (457°C) and pressure up to 850 PSI (5860 KPa) at 70°F (21°C).

Temperature: As working temperature increases, the pressure ratings of corrugated hose decreases.

Allowable Motion: Flexible pump connectors will absorb vibration, release stress from mating equipment and allow the correction of some misalignment.

ST // Standard Male Threaded Connectors

(See chart on page 10)



Body: Stainless steel single braided corrugated hose with ASA #150 carbon steel plate flanges welded at each end.

Sizes: From 2" to 14" (50mm to 350mm)

Lengths: From 10" to 20" (250mm to 500 mm)
other lengths also available.

Braided Hose: Gives a high temperature leak proof, with appropriate fittings attached you have a connector which allows temperature up to 850°F (457°C) and pressure up to 850 PSI (5860 KPa) at 70°F (21°C).

Temperature: As working temperature increases, the pressure ratings at corrugated hose decreases.

Allowable Motion: Flexible pump connectors will absorb vibration, release stress from mating equipment and allow the correction of some misalignment.

Note: Install all pump connectors in a straight line without offset. Piping must be anchored or hung so that the weight of the piping does not rest on the pump connector.

SM // Standard Flanged Connectors

FLO FAB'S STAINLESS STEEL FLEXIBLE SERIES ST

• ST

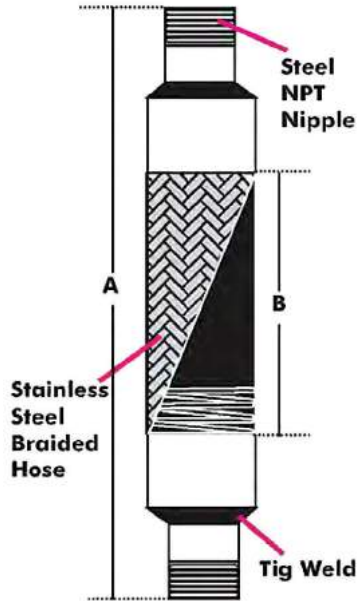

***Other sizes are available but not shown**

Dimensions (in/mm)					(lbs/kg)
Models	Sizes	A	B	Pressure @ 70°F(21°C)	Weight
ST0050-10	1/2" 15mm	9 3/4" 247.65mm	6 1/2" 165.1mm	750PSI 5172kPa	0.5lbs 0.2kg
ST0075-10	3/4" 20mm	9 7/8" 248.92mm			0.75lbs 0.3kg
ST0100-10	1" 25mm	9 3/4" 247.65mm	6" 152.4mm	650PSI 4482kPa	1lbs 0.4kg
ST0125-10	1 1/4" 32mm	10 1/8" 256.64mm			1.5lbs 0.6kg
ST0150-10	1 1/2" 40mm	9 7/8" 248.92	5 1/2" 139.7mm	500PSI 3448kPa	2lbs 0.9kg
ST0200-14	2" 50mm	13 3/4" 349.25mm	7 1/2" 101.6mm	475 PSI 3275	2.5lbs 1.1kg

Temperature Conversion Factors						Maximum Service Temperature					
Apply to pressure rating for elevated temperature											
Temperature		Material				Alloy	Maximum		Alloy	Maximum	
°C	°F	Stainless Steel	Steel	Monel	Bronze		°C	°F		°C	°F
21	70	1.00	1.00	1.00	1.00	AISI Stainless Steel Type			Brazing(RCuZn-C or BCuP-2)	232	450
65	150	0.97	0.99	0.93	0.92	321	815	1500	Bronze Hose	454	850
93	200	0.94	0.97	0.90	0.89	316 ELC			Steel Hose	315	600
121	250	0.92	0.96	0.87	0.86	304	454	850	Silver Brazing (AWS-B-Ag-2)		
148	300	0.88	0.93	0.83	0.83	302			Asbestos Packing Grade		
176	350	0.86	0.91	0.82	0.61	Mild Steel	426	800	Commercial Asbestos	204	400
204	400	0.83	0.87	0.79	0.78	Malleable Iron			Underwriters Asbestos	232	450
232	450	0.81	0.86	0.77	0.75	Monel	232	450	A Asbestos	287	550
260	500	0.78	0.81	0.73		Bronze			AA Asbestos	315	600
315	600	0.74	0.74	0.72		Brass	204	400	AAA Asbestos	398	750
371	700	0.70	0.66	0.71		Cooper			AAAA Asbestos	482	900
426	800	0.66	0.52	0.70		Aluminium 525-0(5062-0)	315	600	Cotton Cord Packing	93	200
482	900	0.62	0.50			Galvanizing	232	450			
537	1000	0.60				Soft Solder(Pb: 60 Sn:40)	121	250			
593	1100	0.58				(Pb: 95 Sn:5)	176	350			
648	1200	0.55									
704	1300	0.50									
760	1400	0.44									
815	1500	0.40									

Dimensions not to be used for construction unless prints certified by factory.
Dimensions are subject to change without prior notice

Also Available with steel hex male nipple up to 2" diameter

FLO FAB'S STAINLESS STEEL FLEXIBLE SERIES SM

● SM

*Other sizes are available but not shown

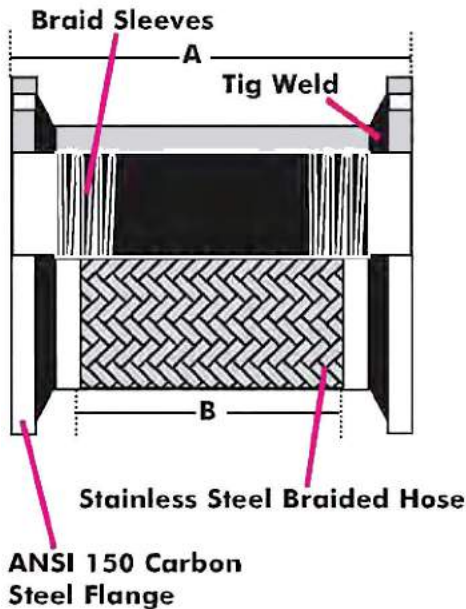

MODELS	Sizes	Dimensions (in/mm)		Pressure @ 70°F(21°C)	(lbs/kg)
		A	B		Weight
SM0250-10	2 1/2"	10 5/16"	7 1/4"	375PSI 2585kPa	19lbs 8.6kg
	65mm	261.62mm			
SM0300-10	3"	10"	184.15mm	325PSI 2240kPa	22lbs 10kg
	80mm	254mm			
SM0400-11	4"	11 1/2"	222.25mm	300PSI 2068kPa	29lbs 13.1kg
	100mm	292.1mm			
SM0500-13	5"	13"	241.3mm	200PSI 1380kPa	36lbs 1.3kg
	125mm	330.2			
SM0600-14	6"	14 1/4"	266.7mm	175PSI 1206kPa	42lbs 19kg
	150mm	361.95mm			
SM0800-15	8"	15 1/2"	292.1mm	150PSI 1034kPa	74lbs 33.5kg
	200mm	393.7mm			
SM1000-17	10"	17 3/4"	323.85mm	125PSI 862kPa	90lbs 40.8kg
	250mm	450.85mm			
SM1200-18	12"	18 3/8"	355.6mm	105PSI 724kPa	134lbs 60.8kg
	300mm	467.36mm			
SM1400-20	14"	20"	406.4mm		180lbs 81.7kg
	350mm	508mm			

MODELS	Nom Dia. & Overall length	Dimensions (in/mm)		Temperature (PSI/kPa)		
		Max Offset		Maximum Working Pressure		
		Intermittent	Static	@ 70°F	@ 250°F	@400°F
SM0250-10	2 1/2 x 10" (63.5 x 254mm)	1/16" (1.59mm)	1/8" (3.175mm)	275PSI 1895kPa	253PSI 1743kPa	204PSI 1406kPa
SM0300-10	3 x 10" (76.2 x 254mm)			275PSI 1895kPa	253PSI 1743kPa	204PSI 1406kPa
SM0400-11	4 x 11" (101.6 x 279.4mm)		3/16" (4.76mm)	230PSI 1585kPa	200PSI 1378kPa	180PSI 1240kPa
SM0500-13	5 x 13" (127 x 330.2mm)		1/8" (3.175mm)	190PSI 1309kPa	165PSI 1137kPa	150PSI 1034kPa
SM0600-14	6 x 14" (152 x 355.6mm)		3/16" (4.76mm)	135PSI 930kPa	120PSI 827kPa	105PSI 723kPa
SM0800-15	8 x 15" (203.2 x 381mm)		1/8" (3.175mm)	235PSI 1619kPa	205PSI 1412kPa	185PSI 1275kPa
SM1000-17	10 x 17" (254 x 431.8mm)			230PSI 1585kPa	200PSI 1378kPa	180PSI 1240kPa
SM1200-18	12 x 18" (304.8 x 457.2mm)			160PSI 1102kPa	140PSI 965kPa	125PSI 861kPa
SM1400-20	14 x 20" (355.6mm x 508mm)		1/8" (3.175mm)	105PSI 723kPa	N/A	N/A



Flange: SS304/SS316
 Tube: SS304/SS316
 Work temperature: -50°C~450°C
 Flange STD, GB7306, BS21, DIN2999, ANSI, B1.20.1
 Size: DN15~DN400



SMF // Threaded end double ball rubber connector

Dimensions not to be used for construction unless prints certified by factory.
 Dimensions are subject to change without prior notice.

• DUT



Body: Spherical shape, stronger than the standard cylindrical shape. The spherical designed «long-arch» reduces turbulence and sediment build-up. #150 MI Union fittings at both ends.

Ratings: Up to 214 PSI (1475 kPa) and up to 240°F (115°C)

Sizes: From 1/2" to 2" (15mm to 50mm)

Allowable Motion: Spherical bellows can absorb many times the movements of standard products. Compression, extension, deflection and angular movements are easily handled. High pressure molding of EPDM results in lighter weight and thinner wall sections that requires less force to deflect than other products. Reducing and preventing stresses and strains on flanges or piping. Series DUT allows angular motion to 45° angle.

Corrosion Resistance: EPDM offers excellent chemical resistance. Under normal conditions, extensive service life can be expected from EPDM material.

Vibration, Noise & Shock: Reduces noise, sound losses energy travelling axially through the EPDM bellows. Reduces vibrations, insulates the equipment to allow free movement on its vibration mountings.

DUT // EPDM Union Arch Flexibles Series

Dimensions (in/mm)	MODELS	Sizes	A	Allowable Movements				Pressure @ 70°F(21°C)	Weight
				Compression	Extension	Lateral	Angular		
	DUT0050	1/2" 15mm	6 3/4" 171.45mm	7/8" 20.32mm	1/4" 6.35mm	7/8" 20.32mm	45°	150 PSI 1034 kPa	2lbs 0.9kg
	DUT0075	3/4" 20mm	8" 203.2mm						
	DUT0100	1" 25mm	8 1/4" 209.55mm						
	DUT0125	1 1/4" 32mm	8 7/8" 223.52mm						
	DUT0150	1 1/2" 40mm	8 1/2" 215.9mm						
	DUT0200	2" 50mm	9 1/2" 241.3mm						

Dimensions not to be used for construction unless prints certified by factory.

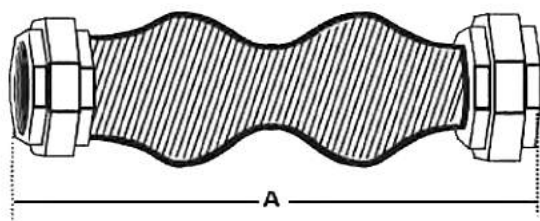

● SSP & DSP

(See chart on page 13)



Body: Spherical shape, stronger than the standard cylindrical shape. The spherical designed «long-arch» reduces turbulence and sediment build-up. ANSI #150 flanges at both ends.

Ratings: Up to 214 PSI [1475 kPa] and up to 240°F (115°C)

Sizes: From 1 1/2 to 20" (40mm to 500mm)

Allowable Motion: Spherical bellows can absorb many times the movements of standard products. Compression, extension, deflection and angular movements are easily handled. High pressure molding of EPDM results in lighter weight and thinner wall sections that requires less force to deflect than other products. Reducing and preventing stresses and strains on flanges or piping. Series SSP allows standard motion.

Corrosion Resistance: EPDM offers excellent chemical resistance. Under normal conditions, extensive service life can be expected from EPDM

Vibration, Noise & Shock: Reduces noise, sound loses energy travelling axially through the EPDM bellows. Reduces vibrations, insulates the equipment to allow free movement on its vibration mountings.

SSP // EPDM Single Arch Flexibles

(See chart on page 14)



Body: Spherical shape, stronger than the standard cylindrical shape. The spherical designed «long-arch» reduces turbulence and sediment build-up. ANSI #150 Flanges at both ends.

Ratings: Up to 214 PSI (1475 kPa) and up to 240°F 115°C

Sizes: From 1 1/2" to 14" (40mm to 350mm)

Allowable Motion: Spherical bellows can absorb many times the movements of standard products. Compression, extension, deflection and angular movements are easily handled. High pressure molding of EPDM results in lighter weight and thinner wall sections that requires less force to deflect than other products. Reducing and preventing stresses and strains on flanges or piping. Series DSP allows extra motion.

Corrosion Resistance: EPDM offers excellent chemical resistance. Under normal conditions, extensive service life can be expected from EPDM

Vibration, Noise & Shock: Reduces noise, sound loses energy travelling axially through the EPDM bellows. Reduces vibrations, insulates the equipment to allow free movement on its vibration mountings.

DSP // EPDM Double Arch Flexibles

FLO FAB'S EPDM SINGLE ARCH FLEXIBLE SERIES: SSP

● SSP

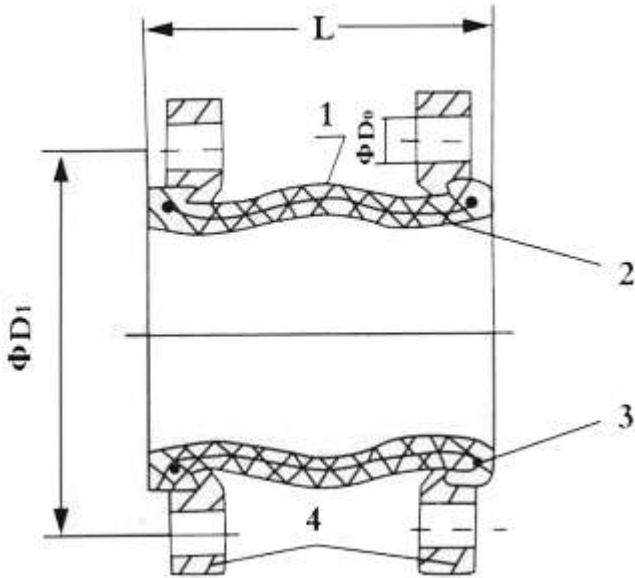

NO.	PARTS	MATERIAL
1	Main Body	Polarized rubber
2	Lining	Nylon cord fabric
3	Frame	Hard steel wire
4	Flange	Mild Steel

Nominal core diameter	1 1/4" ~ 12" 31.75mm ~ 304.8mm	14" ~ 20" 355.6mm ~ 508mm
Working pressure	214PSI - 1475.48kPa	114PSI - 786kPa
Bursting pressure	645PSI - 4447.12kPa	340PSI - 2344.22kPa
Vacuity	12.57PSI - 86.65kPa	7.73PSI - 53.33kPa
Applicable temp	-4~240°F // -20~116°C	
Applicable media	Air, Compressed air, Water, Sea water, Hot water, Weak acid, etc	

MODELS	Nominal Core diameter		Length		No. of bolt	Diam. of bolt hole Do		Diameter of bolt hole Center circle		Axial displacement (IN/mm)		Lat. disp. IN/mm	An-gu-lar °	Weight lbs/kg
	IN	mm	IN	mm		IN	mm	IN	mm	Stretch	Compr.			
SSP0250	2 1/2	63.5	6	152.4	4	3/4	19.05	5 1/2	139.7	1/2"	3/4	9/16	14.29	13/5.8
SSP0300	3	76.2						6	152.4					
SSP0400	4	101.6						7 1/2	190.5					
SSP0500	5	127			8	7/8	22.23	8 1/2	215.9					
SSP0600	6	152.4						9 1/2	241.3					
SSP0800	8	203.2						11 1/4	285.75					
SSP1000	10	254	8	203.2	12	1	25.4	14 1/4	361.95	5/8"	1	7/8	22.23	55/24.9
SSP1200	12	304.8						17	431.8					
SSP1400	14	355.6						16	1 1/8					
SSP1600	16	406.4			21 1/4	539.75								
SSP1800	18	457.2			22 3/4	577.85								
SSP2000	20	508			18	1 1/4	31.75	25	635					
SSP2400	24	609.6	10 7/16	265.1				20	29 1/2	749.3	122/55.2			
														148/67
														unknown

Dimensions not to be used for construction unless prints certified by factory.

Easy Installation: The floating, metallic flanges rotate readily on the bellow compensating for mating flange rotational misalignment. Extra retaining rings or gasket are not required. The rigid metallic flange prevent seepage-sweeping. All flanges are drilled to #150 ASA standard drilling pattern (other drilling patterns available on demand) See chart for Flange/bolting dimensions. All face to face dimensions are shown from gasket to gasket (the gasket is an integral part of the joint).

FLO FAB'S EPDM DOUBLE ARCH FLEXIBLE SERIES: DSP

● DSP

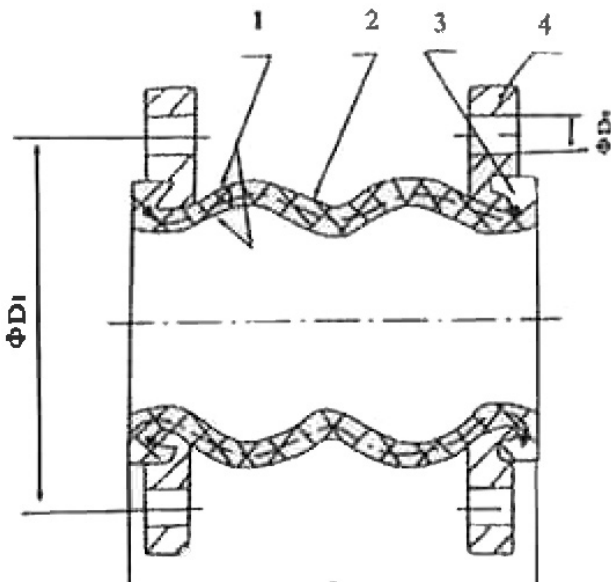

NO.	PARTS	MATERIAL
1	Main Body	Polarized rubber
2	Lining	Nylon cord fabric
3	Frame	Hard steel wire
4	Flange	Mild Steel

Working pressure	214PSI - 1475.48kPa
Bursting pressure	645PSI - 4447.12kPa
Vacuity	12.57PSI - 86.65kPa
Applicable temp	-4~240°F // -20~116°C
Applicable media	Air, Compressed air, Water, Sea water, Hot water, Weak acid, etc

MODELS	Nominal Core diameter		Length		No. of bolt N	Diam. of bolt hole Do		Diameter of bolt hole Center circle		Axial displacement (IN/mm)		Lat. disp. IN/mm	An-gu-lar °	Weight lbs/kg
	IN	mm	IN	mm		IN	mm	IN	mm	Stretch	Compr.			
DSP0250	2 1/2	63.5	7	177.8	4	3/4	19.05	5 1/2	139.7	1 3/16	2	1 7/8 47.63	40°	13/5.8 15/6.7
DSP0300	3	76.2						6	152.4	30.16				
DSP0400	4	101.6	9	228.6	8	7/8	22.23	7 1/2	190.5	1 3/8 34.93	50.8	1 5/8 41.28	35°	20/9 26/11.7 30/13.5
DSP0500	5	127						8 1/2	215.9					
DSP0600	6	152.4						9 1/2	241.3					
DSP0800	8	203.2	13	330.2	12	1	25.4	11 1/4	285.75	2 1/2 63.5	34.93	1 3/8 34.93	30°	46/20.8 63/28.5 115/52
DSP1000	10	254						14 1/4	361.95					
DSP1200	12	304.8						17	431.8					
DSP1400	14	350						1 1/8	28.58					

Dimensions not to be used for construction unless prints certified by factory.
Dimensions are subject to change without prior notice.

Easy Installation: The floating, metallic flanges rotate readily on the bellow compensating for mating flange rotational misalignment. Extra retaining rings or gasket are not required. The rigid metallic flange prevent see-page-sweeping. All flanges are drilled to #150 ASA standard drilling pattern (other drilling patterns available on demand) See chart for Flange/bolting dimensions. All face to face dimensions are shown from gasket to gasket (the gasket is an integral part of the joint).

• Typical Specifications

Typical Specifications for Stainless Steel Flexibles

Supply and install shown on plans FLO FAB stainless steel braided metal flexible connectors. Pump connectors are made only in series 300 stainless steel with stainless corrugated inner tubing and an outer shield of stainless wire braid. Steel fixed flanges ASA #150 standard or SCH40 nipples are used as end fittings.

Maximum temperature is 850°F (457°C). Maximum working pressure ranges from 850 PSI (5850 kPa) at 1/2" (15 mm) to 150 PSI (1034 Kpa) at 14" (350 mm). Lengths vary from 10" (250 mm) to 20" (500 mm). Other than standard lengths are available.

Available Sizes:

Model ST flexible connector (with F.N.P.T. connections): From 1/2" (15 mm) to 2" (50mm)
 Model SM flexible connector with flanges: From 2" (50 mm) to 20" (500 mm)

Typical Specifications for EPDM Steel Flexibles

Supply and install as shown on plans FLO FAB EPDM flexible connectors. Each unit shall be molded on EPDM, the sphere combines the strength of the spherical shape, the flexibility of rubber and the durability of alignable steel flanges. It also offers maximum deflection, elongation and compression.

The spherical designed «long-arch» reduces turbulence and noises.

The floating flanges are standard #150 ASA drilled to mate.

Each unit shall be capable of working pressures up to 214 PSI (1475 Kpa) and temperatures up to 240°F (115°C)

Available Sizes:

Model SSP-EPDM single flexible connector with flanges: From 1 1/2" (40 mm) ID to 20" (500 mm) ID
 Model DSP-EPDM dual flexible connector with flanges: From 1 1/2" (40 mm) ID to 14" (300 mm) ID
 Model DUT-EPDM union flexible connector with F.N.P.T. end: From 1/2" (20 mm) ID to 2" (50 mm) ID

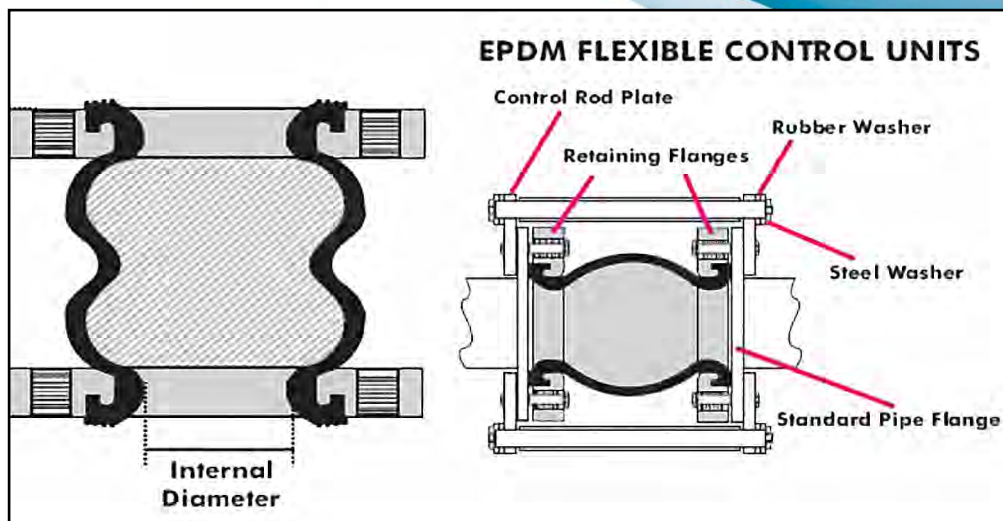

● LCTY & LYF

(See chart on page 17)



Body: ASTM A126 Class B Cast Iron

Rating/Steam:

- 250 PSI (1723.69kPa) at 406°F (207.7B°C)
- 400 PSI (2757.90 kPa) at 150°F (65.56°C)

Standard Screens:

Diameter from 1/2" to 2" (15mm to 50mm),
Opening 1/32" (0.8mm)
STD. Mesh/Peri: 20 Mesh

LCTY // Threaded cast iron Y-strainer

(See chart on page 18)



Body: ASTM A126 Class B Cast Iron

Rating/Steam:

- 250 PSI (1723.69kPa) at 406°F (207.7B°C)
- 400 PSI (2757.90 kPa) at 150°F (65.56°C)

Standard Screens:

Diameter from 1/2" to 2" (15mm to 50mm),
Opening 1/32" (0.8mm)
STD. Mesh/Peri: 20 Mesh

LYF // EPDM Double Arch Flexibles

● LCTY

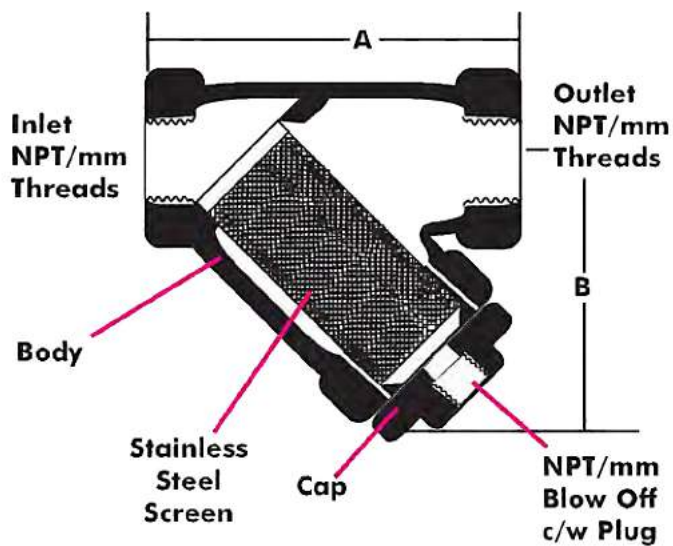

MODELS	Diameter	A	B	Blow Off	Weight
LCTY0050	1/2" 15mm	3" 76.2mm	2 1/2" 63.5mm	3/8" NPT 10.16mm	1.76 lbs 0.8 kg
LCTY0075	3/4" 20mm	4" 101.6mm	2 3/4" 69.5 mm	1/2" NPT 12.7 mm	2.65 lbs 1.2 kg
LCTY0100	1" 25mm	4 9/16" 115.89mm	3 1/2" 88.9mm		3.97 lbs 1.8 kg
LCTY0125	1 1/4" 32mm	5 1/4" 133.35mm	4" 101.6mm	3/4" NPT 19.05 mm	7.06 lbs 3.2 kg
LCTY0150	1 1/2" 40mm	6 1/8" 155.58mm	4 5/8" 115.57mm		8.38 lbs 3.8 kg
LCTY0200	2" 50mm	7 3/8" 187.33mm	5 1/2" 139.7mm	1" NPT 25.4 mm	13 lbs 5.9 kg

FLO FAB'S THREADED Y STRAINER SERIES LYF

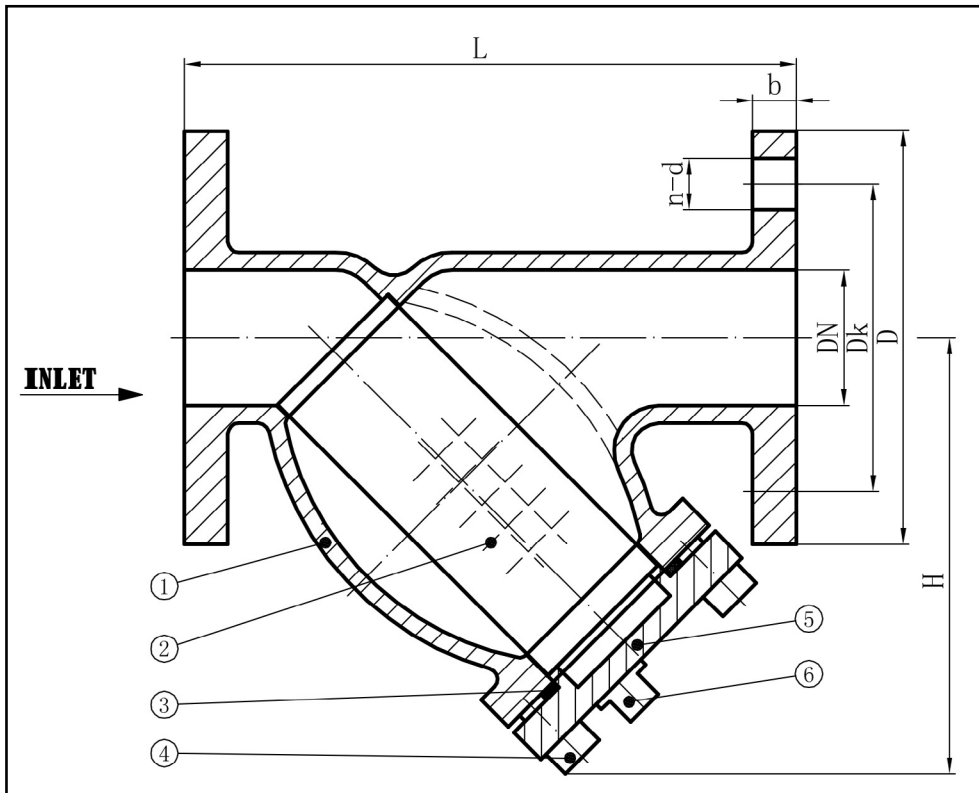

STANDARD SCREENS (IN/mm)		
Size	Opening	Std: Mesh/Perf
2"-3" 50.8-76.2	0.045" 1.14	3/64" 1.19
4"-12" 101.6-304.8	0.125" 3.18	1/8" 3.18

NO.	PARTS	MATERIAL
1	Body	Cast Iron
2	Screen	Stainless Steel
3	Body Gasket	PTFE/Graphite
4	Bolts	Steel
5	Cover	Cast Iron
6	Plug	Cast Iron

NO.	PARTS	USA Standard
1	Body	ASTM A 126 Class B
2	Screen	ASTM SS 304
3	Body Gasket	PTFE/NON ASBESTOS
4	Bolts	ASTM A307 B
5	Cover	ASTM A126 Class B
6	Plug	ASTM A 126 Class B

DIMENSIONS IN INCHES							
MODEL	DN	L	Dk	D	b	n-d	H
LFY0200	2	8.87	4.76	5.98	0.63	.16-.75	6.34
LFY0250	2.5	10.75	5.51	7.01	0.69		7.20
LFY0300	3	11.50	6.00	7.48	0.75		8.62
LFY0400	4	13.86	7.50	9.02	0.94	.31-.75	9.37
LFY0500	5	16.38	8.50	10.00	0.94	.31-.87	10.24
LFY0600	6	18.50	9.50	10.98	1.00		12.40
LFY0800	8	21.38	11.75	13.50	1.13		15.75
LFY01000	10	26.00	14.25	15.98	1.19	.47-.98	18.98
LFY01200	12	30.00	17.01	19.02	1.25		20.87
LFY1400	14	37.36	18.74	20.98	1.38		.47-1.14
LFY1600	16	42.50	21.26	23.50	1.44	.63-1.14	25.59
LFY1800	18	47.24	22.76	25.00	1.56	.63-1.26	37.68

OPERATING PRESSURE AND TEMPERATURE	
2"-12" 50.8 - 304.8mm	Steam: 150PSIG at 450°F
14" 355.6mm	Steam: 150PSIG at 450°F
2"-12" 50.8 - 304.8mm	Water, Oil, Gas: 150 PSIG at 450°F
14" 355.6mm	Water, Oil, Gas: 150 PSIG at 450°F

DIMENSIONS IN MILLIMETERS							
MODEL	DN	L	Dk	D	b	n-d	H
LFY0200	50.8	225.4	121	152	16	4-19	161
LFY0250	63.5	273	140	178	17.5		183
LFY0300	76.2	292	152.5	190	19		219
LFY0400	101.6	352	190.5	229	24	8-19	238
LFY0500	127	416	216	254	24	8-22	260
LFY0600	152.4	470	241.3	279	25.4		315
LFY0800	203.2	543	298.5	343	28.6		400
LFY01000	254	660.4	362	406	30.2	12-25	482
LFY01200	304.8	762	432	483	31.8		530
LFY1400	355.6	949	476	533	35		12-29
LFY1600	406.4	1079.5	540	597	36.6	16-29	650
LFY1800	457.2	1200	578	635	39.6	16-32	957



● **LYF**

● SBS & DBS

(See chart on page 20)



Body: ASTM A126 Class B Cast Iron

Rating/Steam:

2" to 12": 150 PSI (1034.21 kPa) or 450°F (232.22°C)

14" to 16": 150 PSI (1034.21 kPa) at 250°F (121.11°C)

Water, Oil or Gas:

2" to 12" : 200 PSI (1378.95 kPa) at 150°F (65.55°C)

14" to 16" : 150 PSI (1034.21 kPa) at 150°F (65.55°C)

Standard Screens:

Diameters from 2" to 12" (50mm to 300mm)

Opening 1/16" (1.2mm)

STD. Mesh/Peri: 3/64" perf. (1.2mm)

Diameters from 14" to 16" (350mm to 400mm)

Opening 1/8" (3.18mm)

STD. Mesh/Peri: 1/8" perf. (3.18mm)

SBS // Threaded cast iron Y-strainer

(See chart on page 21)



Body: ASTM A126 Class B Cast Iron (Bronze also available)

Rating: Threaded(T)

Clamped Cover: 150 PSI (1034.21 kPa) at 250°F (121.11°C)

Bolted Cover: 400 PSI (2757.90 kPa) at 100°F (37.78°C)

Flanged

Clamped Cover: 150 PSI (1034.21 kPa) at 250°F (121.11°C)

Bolted Cover: 175 PSI (1206.58 kPa) at 250°F (121.11°C)

Standard Screens:

Diameters from 2" to 12" (50mm to 300mm)

Opening 1/16" (1.2mm)

STD. Mesh/Peri: 3/64" perf. (1.2mm)

Diameters from 14" to 16" (350mm to 400mm)

Opening 1/8" (3.18mm)

STD. Mesh/Peri: 1/8" perf. (3.18mm)

DBS // Cast Steel thread end basket strainer

FLO FAB'S SIMPLE BASKET STRAINER SERIES SBS

● SBS

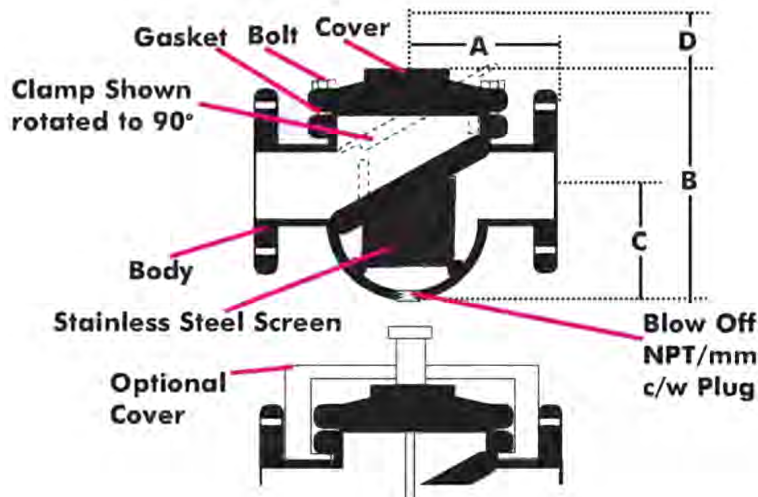

DIMENSIONS (IN/mm)

MODELS	DIAM.	A	B	C	D	Blow off	Weight
SBS0200	2 50.8	8 1/2 215.90	8 3/8 212.73	5 127.00	5 3/8 136.53	1" NPT 25.4mm	22 lbs 10 kg
SBS0250	2.5 63.5	8 3/4 222.25	9 5/8 244.48	5 5/16 134.94	6 5/16 160.34		31 lbs 14.06 kg
SBS0300	3 76.2	9 7/8 250.83	11 1/4 285.75	6 1/2 165.10	8 203.20		42 lbs 19.05 kg
SBS0400	4 101.6	11 1/2 292.10	13 1/2 342.90	8 203.20	9 5/16 236.54		70 lbs 31.75 kg
SBS0500	5 127	13 1/8 333.38	14 5/8 371.48	8 203.20	10 1/4 260.35		90 lbs 40.82 kg
SBS0600	6 152.4	14 7/8 377.83	15 5/8 396.88	8 5/8 219.08	11 1/8 282.58	1 1/4" NPT 31.75mm	124 lbs 56.25 kg
SBS0800	8 203.2	18 2/3 474.66	21 533.40	11 3/4 298.45	15 9/16 395.29	3/4" NPT 19.05mm	270 lbs 122.47 kg
SBS1000	10 254	20 1/8 511.18	24 1/2 622.30	13 3/4 349.25	18 457.20		384 lbs 174.18 kg
SBS1200	12 304.8	26 1/4 666.75	29 3/4 755.65	16 3/8 415.93	23 1/4 590.55	1" NPT 25.4mm	670 lbs 303.91 kg
SBS1400	14 355.6	30 1/4 768.35	36 3/8 923.93	23 1/4 590.55	28 1/8 714.38	1 1/2" NPT 25.4mm	1010 lbs 458.13 kg
SBS1600	16 406.4	31 4/9 798.51	43 1/4 1098.55	29 1/2 749.30	N/A	2" NPT 50.8mm	1320 lbs 598.74 kg
SBS1800	18 457.2	34 863.60	52 1/4 1327.15	36 914.40			1916 lbs 869.08 kg
SBS2000	20 508	36 5/8 930.28	57 7/8 1470.03	40 7/8 1038.23			2460 lbs 1115.8 kg
SBS2400	24 609.6	41 1/2 1054.10	65 3/8 1660.53	46 1/4 1174.75			4550 lbs 2063.8 kg
SBS2800	28 700	N/A	N/A	N/A	N/A	N/A	N/A
SBS3200	32 800	N/A	N/A	N/A	N/A	N/A	N/A

FLO FAB'S DUPLEX BASKET STRAINER SERIES DBS

● DBS

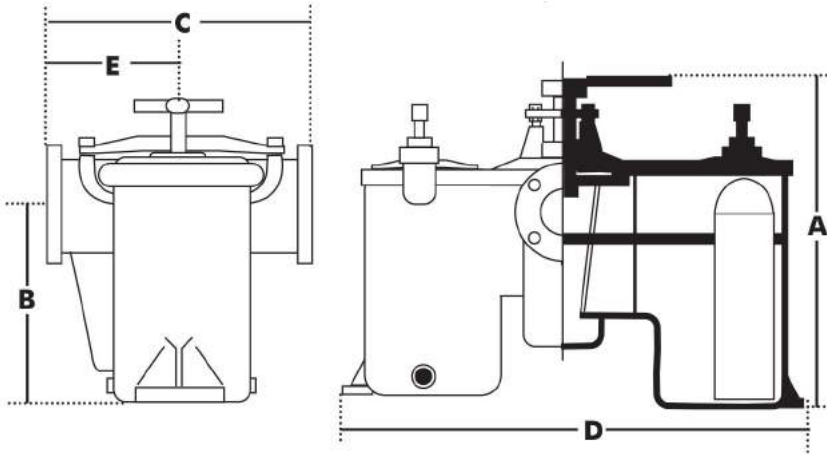

DIMENSIONS (IN/mm) - THREADED

MODELS	DIAM. NPT	A	B	C	D	E	F	Weight
DBS0038T	3/8	N/A	N/A	N/A	N/A	N/A	N/A	N/A
DBS0050T	1/2	N/A	N/A	N/A	N/A	N/A	N/A	N/A
DBS0075T	3/4" 20	12 1/4" 311.15	5 5/8" 140.97	6 3/4" 171.45	14 1/2" 368.3	3 5/8" 90.17	1/4" 6.35	43 lbs 19.5 kg
DBS0100T	1" 25							
DBS0125T	1 1/4" 32	13 1/4" 336.55	6 3/4" 171.45	7 5/8" 191.77	15 1/4" 387.35	3 7/8" 96.52	3/8" 10.16	56 lbs 25.4 kg
DBS0150T	1 1/2" 40							
DBS0200T	2" 50	14 3/4" 374.65	7 7/8" 198.12	10 5/8" 267.97	20 1/2" 520.7	5 9/16" 142.24	3/4" 19.05	115 lbs 52.2 kg
DBS0250T	2 1/2	N/A	N/A	N/A	N/A	N/A	N/A	N/A
DBS0300T	3	N/A	N/A	N/A	N/A	N/A	N/A	N/A

DIMENSIONS (IN/mm) - FLANGED

MODELS	DIAM. NPT	A	B	C	D	E	F	Weight
DBS0250	2 1/2" 65	14 3/4" 374.65	7 7/8" 198.12	12" 304.8	20 1/2" 520.7	6 7/32" 157.99	3/4" 19.05 mm	115 lbs 52.2kg
DBS0300	3" 80	17 5/8" 445.77	10 3/4" 273.05	12 1/2" 317.5	20 3/4" 527.05	6 7/8" 172.72		141 lbs 63.96kg
DBS0400	4" 100	20 11/16" 525.78	13 1/32" 330.96	15 5/8" 394.97	25 1/4" 641.35	8 15/16" 226.06		305 lbs 138.35kg

• Replacement Screen & Basket

Mesh Sizes other than shown
are also available on application

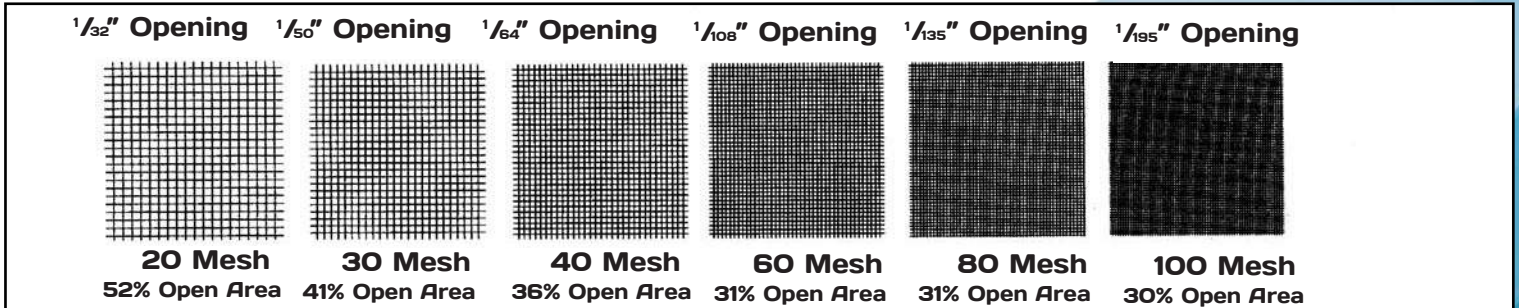

Perforations other than shown are also available (All open area are approximative)

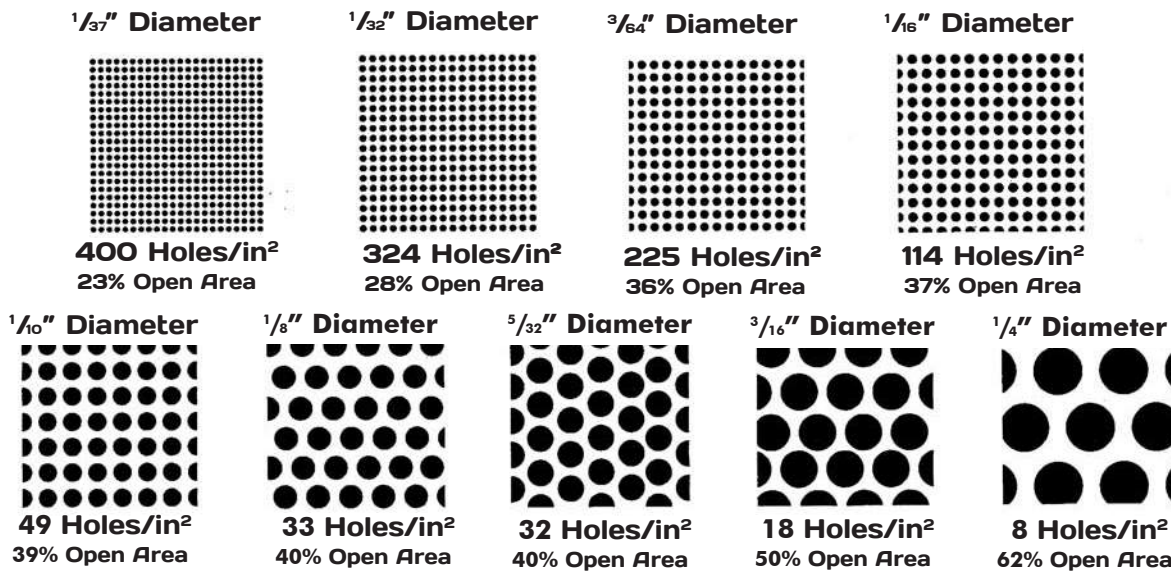

Perforated Metal and Mesh Available

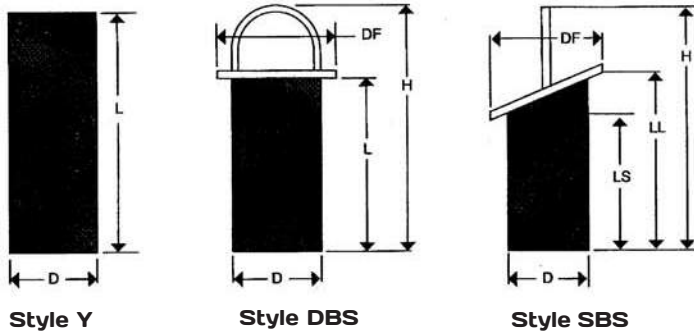

Specify:

- 1) The Style: Y-Y Strainer
DBS - Duplex Basket Strainer
SBS - Simplex Basket Strainer
- 2) Perforation and Mesh
(if liner is required)
- 3) Material (Stainless Steel is standard)
- 4) All lettered dimensions shown on the drawings (D,L,H,DF,LS,LL)

• Strainers Pressure Drop Curves

Flanged Y Strainers

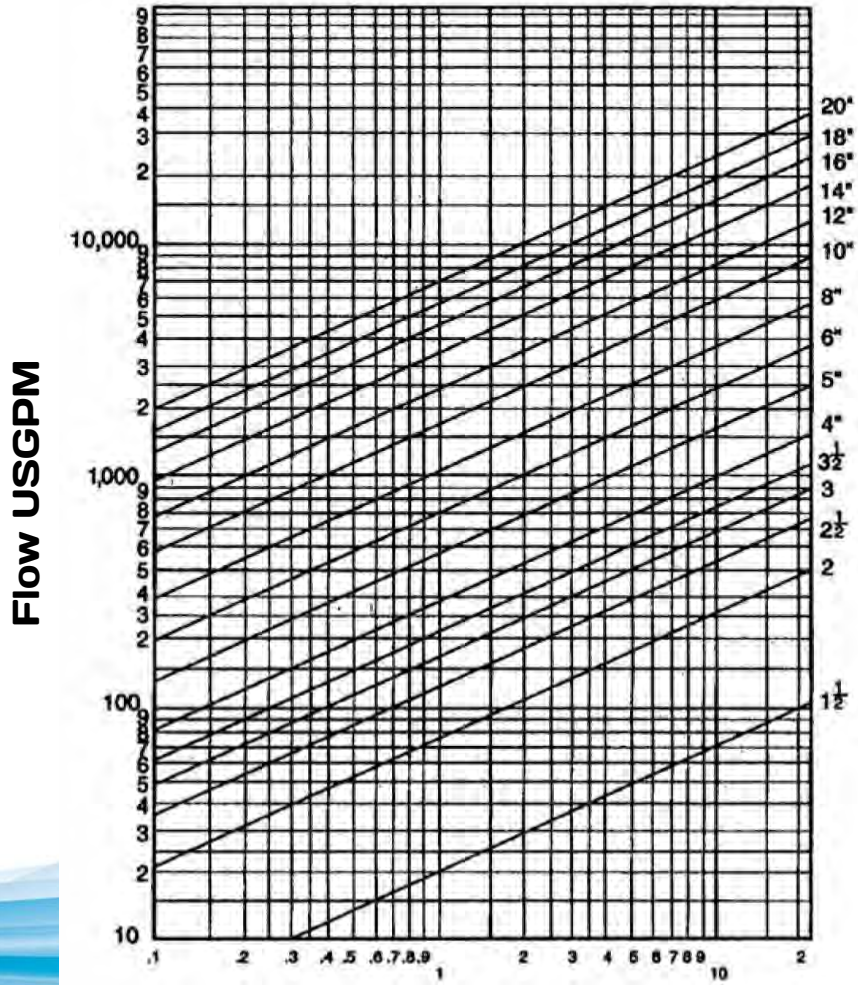

Strainers Size

Pressure Drop PSI

Strainers Size

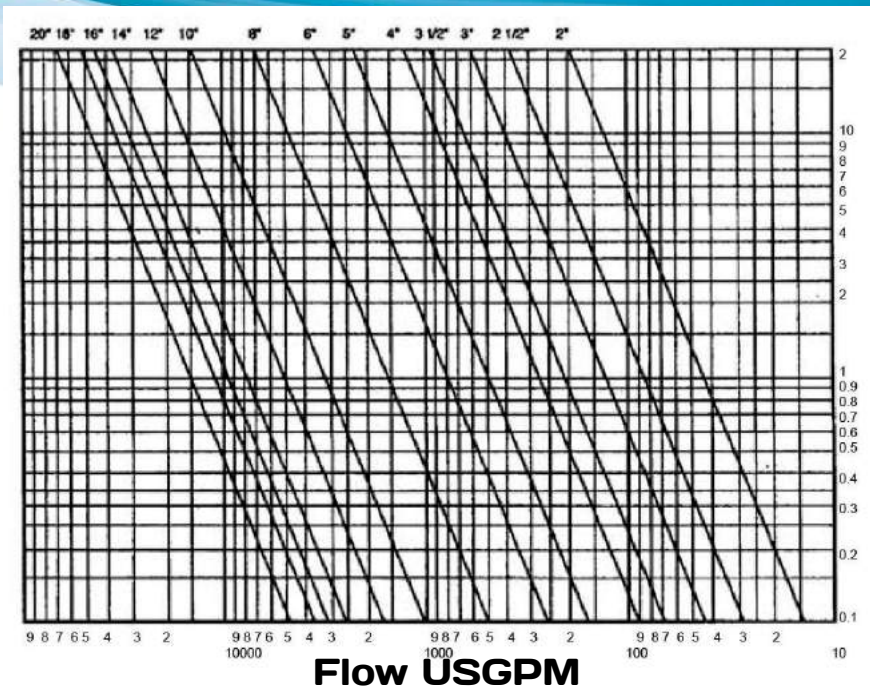

Pressure Drop PSI

Flow USGPM

We are proud supplier for the following completed and on going projects :



444 10th Avenue North
NEW YORK, NY 10001.



Edgemere
1502 LAKESHORE ROAD
E., OAKVILLE, ONTARIO,
CANADA



Bacaro Pizzeria
4259 Sainte-Catherine O.
Westmount, Quebec
H3Z 1P7



TRICENTRIS, Lachute
chemin Félix-Touchette,
Lachute, Quebec, Canada

Sales and Service:

Quebec, Canada
Tel. : (450) 621-2995
Fax : (450) 621-4995

Lake Worth
Florida, USA
33467-5749

Toronto, Canada
Tel. : +1 (647) 544-2995

www.flofab.com

SERVICE 24/7 : parts@flofab.com



<http://www.arcomnet.com/masterspec/>