

# FLO FAB

## End Suction Centrifugal/ Stainless Steel

### Model PST/PSF



[www.flofab.com](http://www.flofab.com)

Manufacturer of Pumps, Tanks, Heat Exchangers & Accessories  
for HVAC Market After-Sales Parts and Services

End Suction Centrifugal/ Stainless Steel  
Model PST/PSF

FLO FAB INC  
LAKE WORTH,  
FLORIDA, USA



## Features

Model **PST / PSF** Close coupled design saves space; simplifies maintenance and installation

- Stainless steel liquid end components  
high quality; corrosion resistance
- Versatile mounting  
can be installed horizontally or vertically
- Back pullout construction  
assembly and overhaul of the impeller and seal without distorting suction and discharge connections
- Top centerline discharge and foot support under casing  
ensures self-venting and reduces misalignment from pipe loads
- High operating efficiency  
lowers operating costs
- High quality mechanical shaft seals and o-rings  
available for standard pumping requirements or optional high temperature and chemical duty operation

## Applications

- **Plant services**
- **Water supply systems**
- **Washing plants**
- **Cooling water**
- **Car wash**
- **Scrubbers**
- **Ultrapure water systems**
- **Jockey pump services**
- **Air conditioning**
- **Sprinkler/flow irrigation**
- **OEM equipment application**
- **Pressure boosting**
- **Liquid transfer**
- **Heat exchanger**
- **Spray systems**
- **Heating**
- **Beverage processing**
- **Pharmaceutical services**
- **Water reclamation and treatment**
- **General pump applications**



**SERIES PS**  
**Specifications**  
**MODEL - PST**

	<b>Standard</b>	<b>Optional</b>
<b>Size</b>		
Suction	PST70: 1/4" NPT thread PST120: 1/4" NPT thread PST200: 1/2" NPT thread	
Discharge	1" NPT thread	
<b>H.P. Range</b>	1/2 H.P. to 3 H.P.	
<b>Performance Range</b>		
Capacity	5.5 to 90 GPM at 3450 R.P.M.	
Head	23 to 144 feet at 3450 R.P.M.	
<b>Liquid Handling</b>		
Liquid Type	Various	
Temperature	Dependent on Mechanical Seal Selection	
Working Pressure	Max. 115 P.S.I.G. (8 Bar)	
<b>Materials</b>		
Casing	304 Stainless Steel	
Impeller (Closed Type)	304 Stainless Steel	
Shaft	Stainless Steel	
Bracket	Aluminum	
Mechanical Seal	Carbon vs. Ceramic (Buna Elastomers)	Various material options for high temperature, corrosive, and abrasive services.
<b>Direction of Rotation</b>	Clockwise when viewed from motor end	
<b>Motor</b>		
Type	NEMA 56J Frame	•Explosion Proof
Speed	60Hz 3450 RPM (2 poles)	•1750 RPM for lower flows and pressures
Single Phase	TEFC: 1/2 H.P. to 3 H.P. ODP: 1/2 H.P. to 3 H.P. 115/230V	
Three Phase	TEFC: 1/2 H.P. to 3 H.P. ODP: 1/2 H.P. to 3 H.P. 208-230/460V and 575V	
Motor Protection	Single Phase: Built-in overload protection Three Phase: Overload protection must be provided	

# FLOFAB

## SERIES PS Cross Section **MODEL - PST** Close-coupled

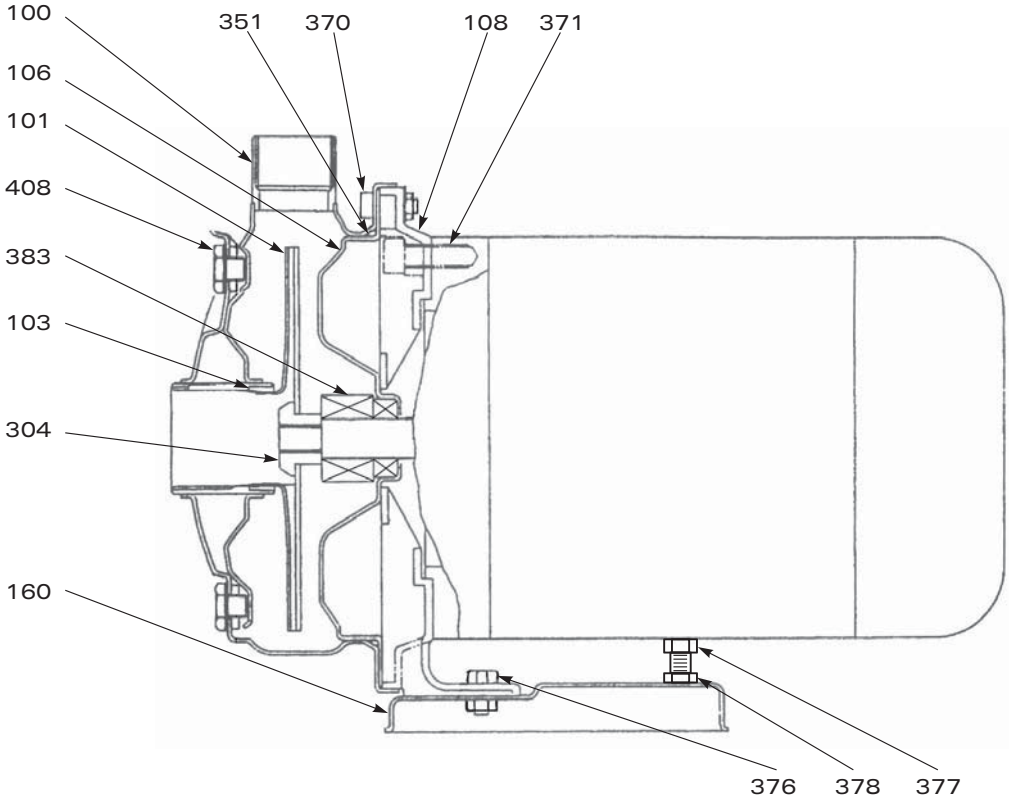

ITEM	QTY REQ'D	DESCRIPTION	MATERIAL
100	1	Casing	304 Stainless steel
101	1	Impeller	304 Stainless steel
103*	1	Casing ring	Viton
106	1	Casing cover	304 Stainless steel
108	1	Adapter	Aluminum
160	1	Motor support	Steel
304	1	Impeller nut	304 Stainless steel
351	1	Casing O-ring	Viton (standard)
370	8	Casing bolt	304 Stainless steel
371	4	Motor bolt	Steel
376	2	Foot bolt	Steel
377	1	Support bolt	Steel
378	1	Support bolt nut	Steel
383	1	Mechanical seal	Various
408	2	Casing plug	304 Stainless steel

\* Required on sizes 701, 703 and 705 only.



# FLOFAB

**SERIES PS**  
**Cross Section**  
**MODEL - PST**  
 Frame mounted

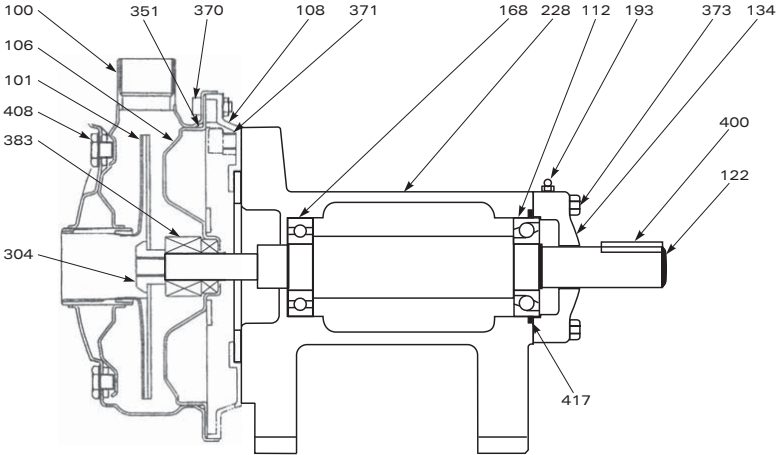

ITEM	QTY REQ'D	DESCRIPTION	MATERIAL
100	1	Casing	304 Stainless steel
101	1	Impeller	304 Stainless steel
103*	1	Casing wear ring	Viton
106	1	Casing cover	304 Stainless steel
108	1	Adapter	Aluminum
112	1	Thrust bearing	Steel
122	1	Shaft	Steel
134	1	Outboard brg cap	Cast iron
168	1	Radial bearing	Steel
178	1	Impeller key	Steel
193	1	Grease fitting	Steel
228	1	Bearing frame	Cast iron
304	1	Impeller nut	304 Stainless steel
351	1	Casing o-ring	Viton (standard)
370	8	Casing bolt	304 Stainless steel
371	4	Frame bolt	Steel
373	4	Bearing cap bolt	Steel
383	1	Mechanical seal	Various
400	1	Shaft key	Steel
408	2	Casing plug	304 Stainless steel
417	1	Retaining ring	Steel

\* Required on sizes 701, 703 and 705 only.



# SERIES PS Specifications **MODEL - PST**

Model PST Selection Chart (1725 RPM)

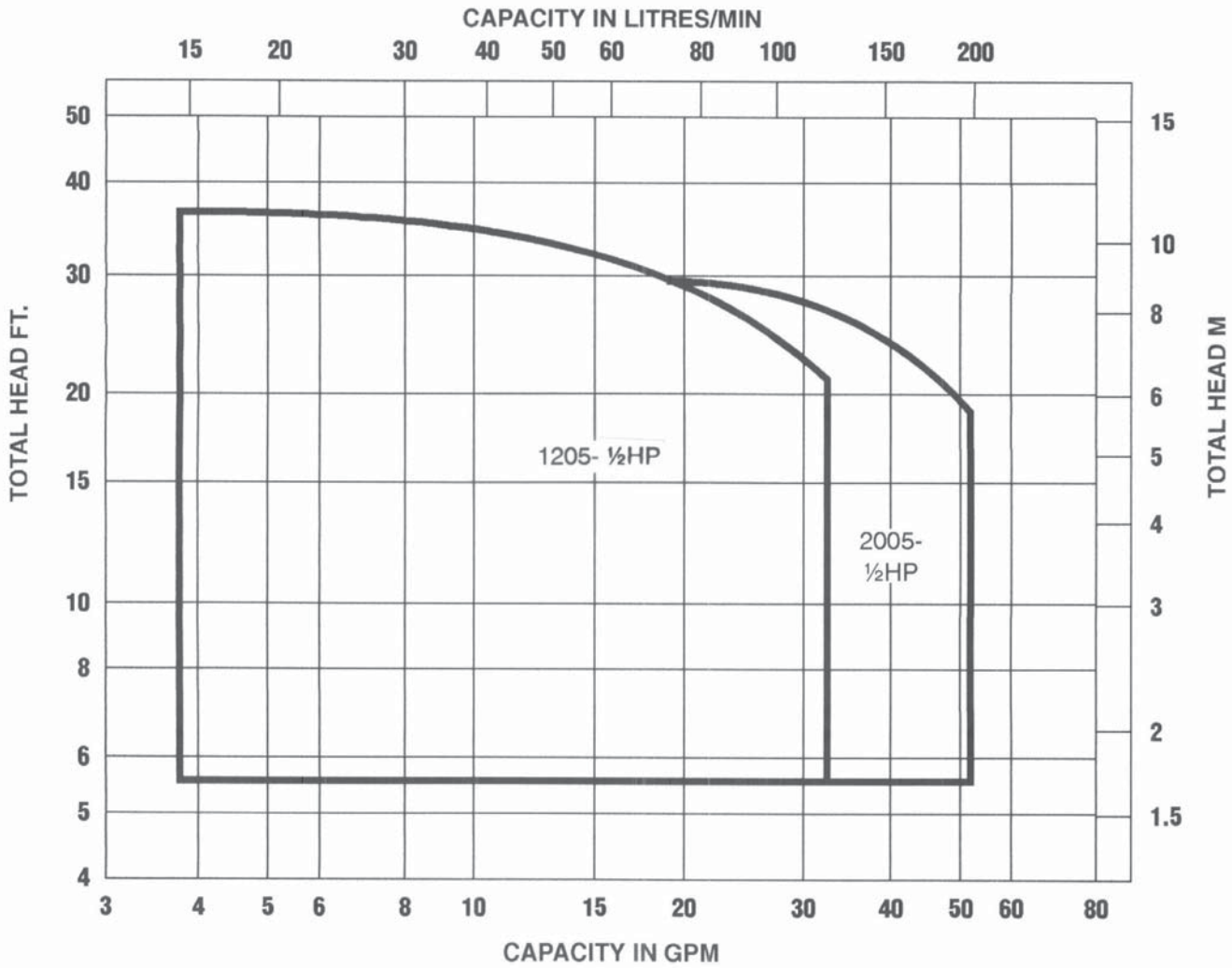



Series PS **MODEL PST1205**

CUSTOMER \_\_\_\_\_ REFERENCE \_\_\_\_\_

FLUID \_\_\_\_\_ S.G. \_\_\_\_\_ TEMP \_\_\_\_\_ CAPACITY \_\_\_\_\_ TDH \_\_\_\_\_

CERTIFIED: \_\_\_\_\_ DATE: \_\_\_\_\_

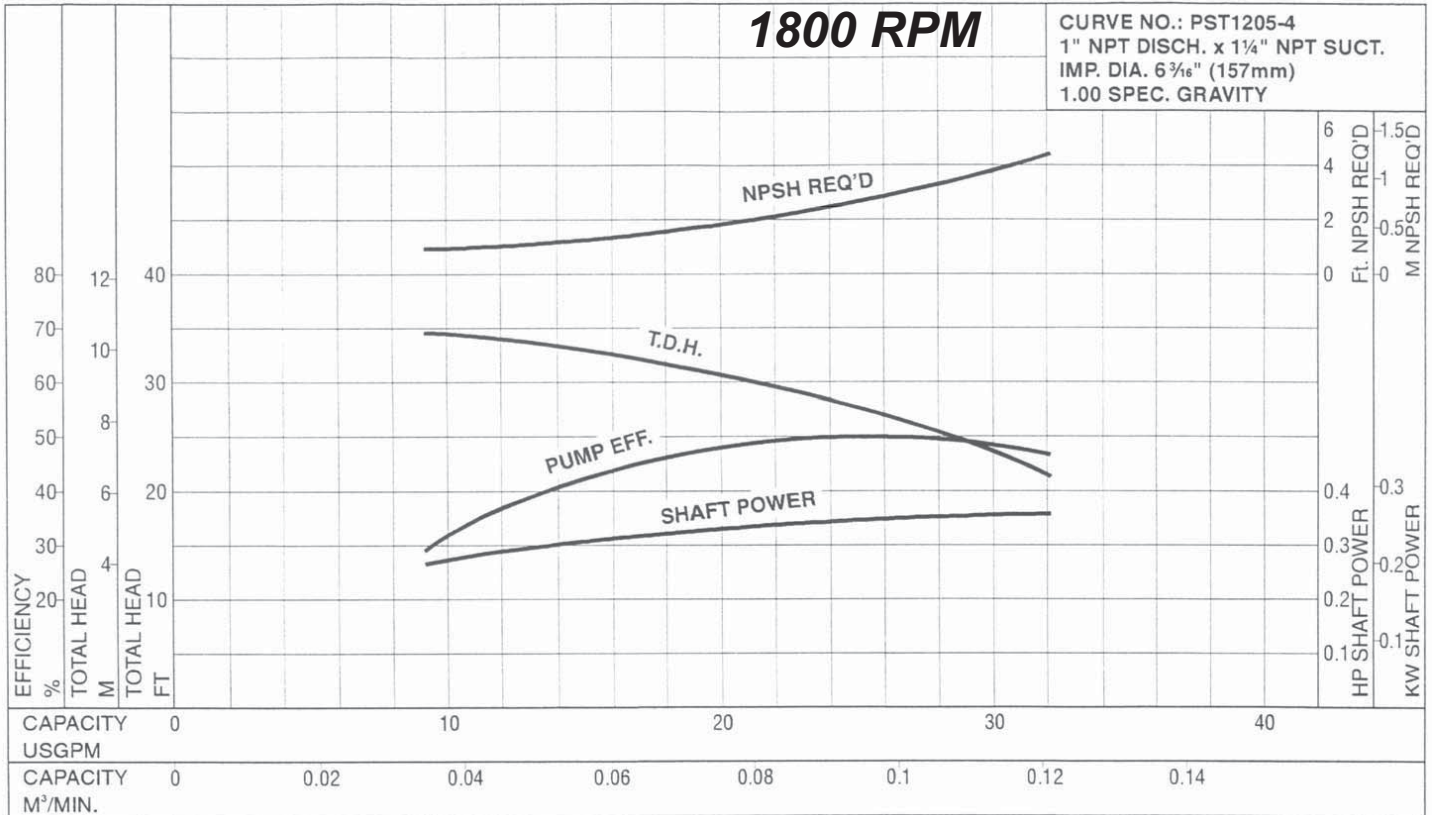



Series PS **MODEL PST2005**

CUSTOMER \_\_\_\_\_ REFERENCE \_\_\_\_\_

FLUID \_\_\_\_\_ S.G. \_\_\_\_\_ TEMP \_\_\_\_\_ CAPACITY \_\_\_\_\_ TDH \_\_\_\_\_

CERTIFIED: \_\_\_\_\_ DATE: \_\_\_\_\_

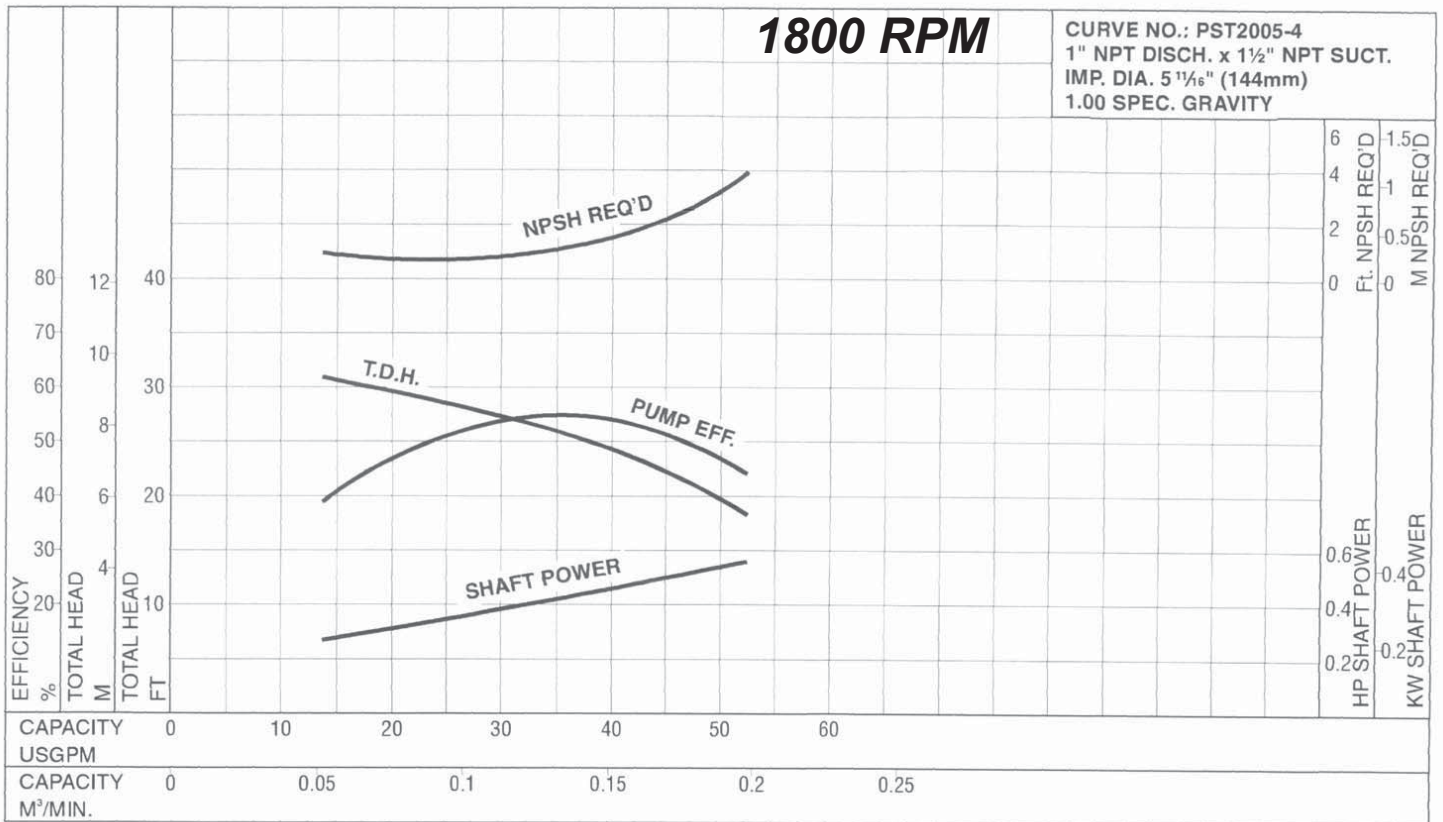





# SERIES PS Specifications **MODEL - PST**

Model PST Selection Chart (3450 RPM)

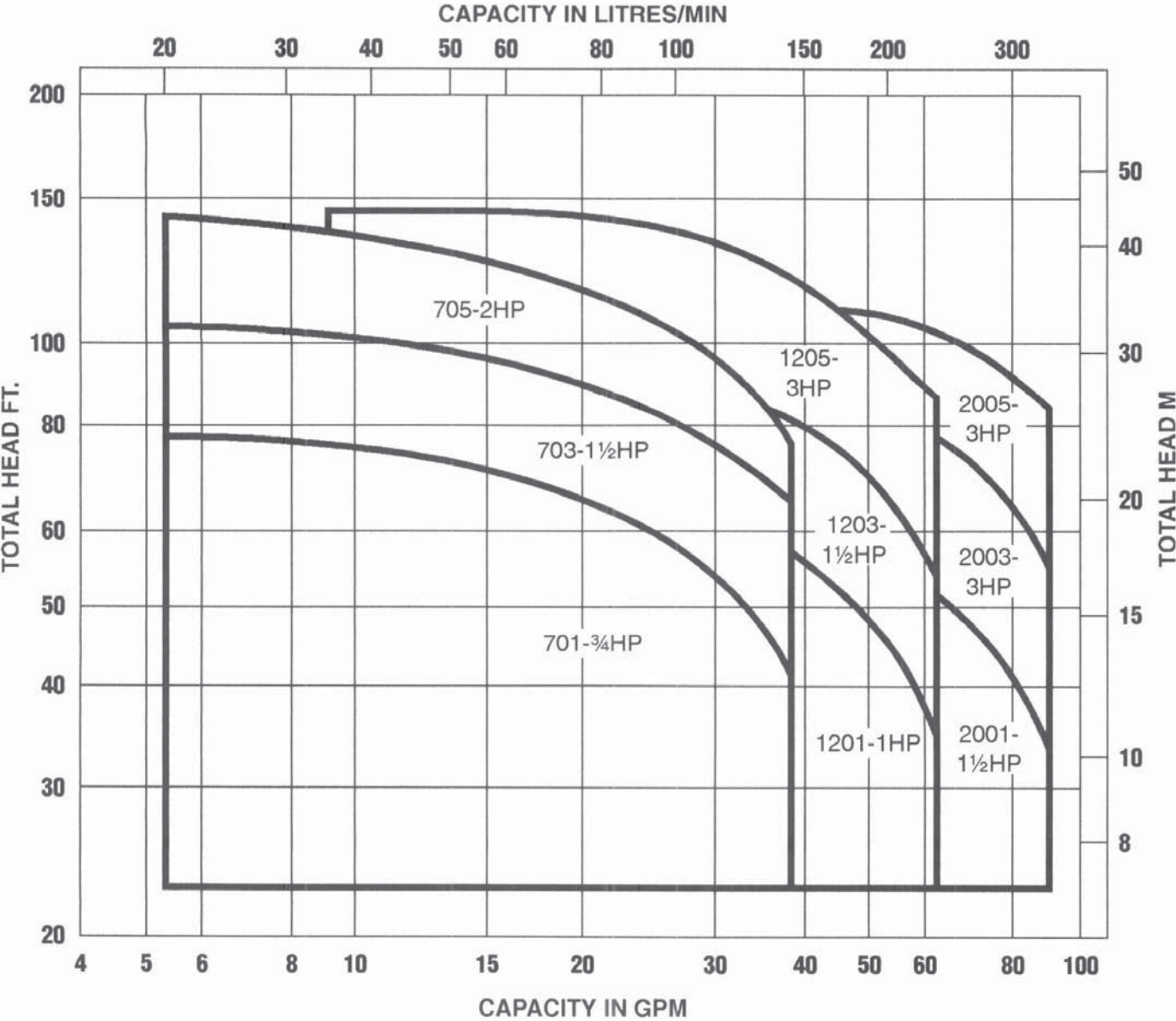



Series PS **MODEL PST701**

CUSTOMER \_\_\_\_\_ REFERENCE \_\_\_\_\_

FLUID \_\_\_\_\_ S.G. \_\_\_\_\_ TEMP \_\_\_\_\_ CAPACITY \_\_\_\_\_ TDH \_\_\_\_\_

CERTIFIED: \_\_\_\_\_ DATE: \_\_\_\_\_

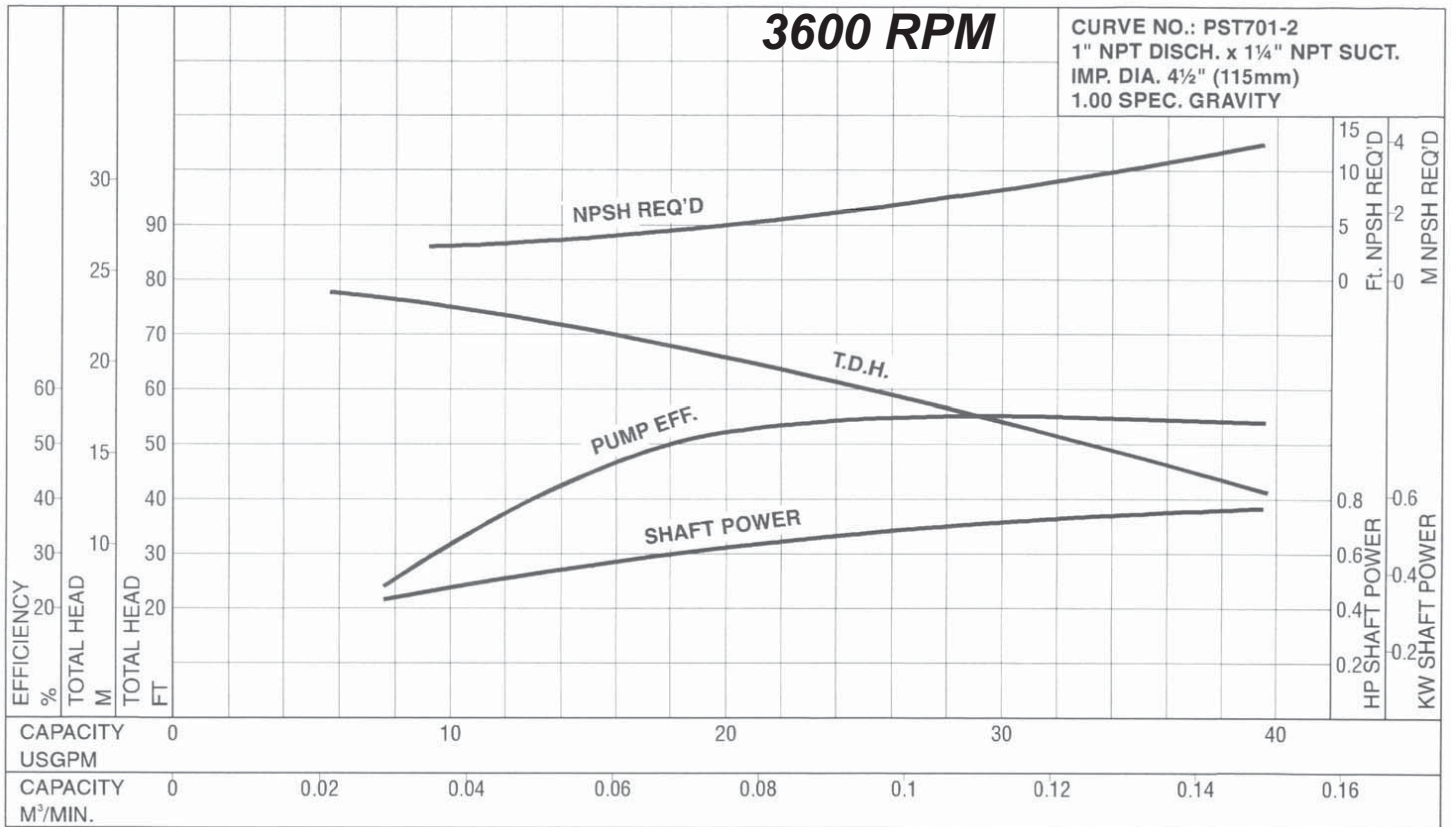



Series PS **MODEL PST703**

CUSTOMER \_\_\_\_\_ REFERENCE \_\_\_\_\_

FLUID \_\_\_\_\_ S.G. \_\_\_\_\_ TEMP \_\_\_\_\_ CAPACITY \_\_\_\_\_ TDH \_\_\_\_\_

CERTIFIED: \_\_\_\_\_ DATE: \_\_\_\_\_

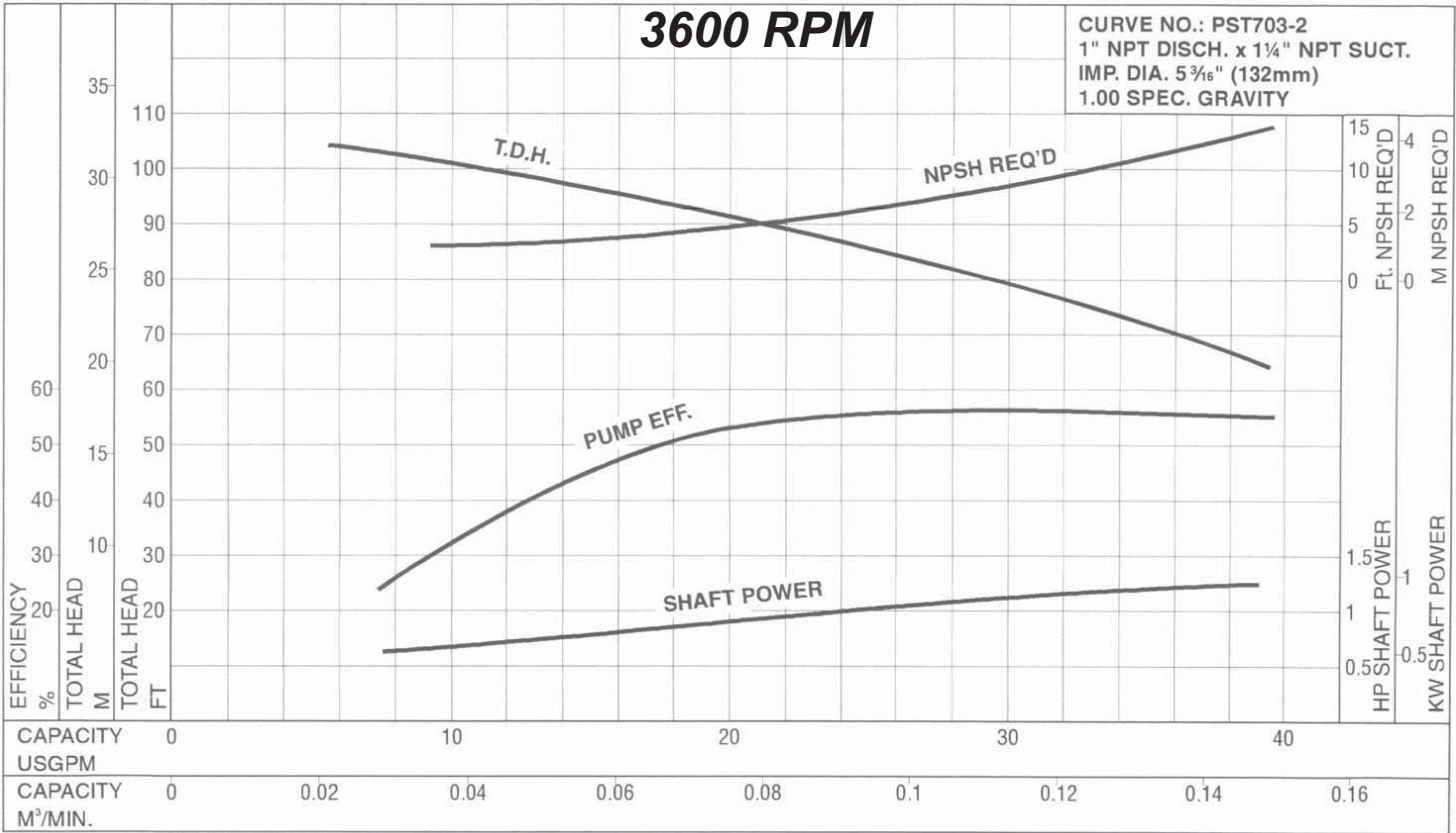



Series PS **MODEL PST705**

CUSTOMER \_\_\_\_\_ REFERENCE \_\_\_\_\_

FLUID \_\_\_\_\_ S.G. \_\_\_\_\_ TEMP \_\_\_\_\_ CAPACITY \_\_\_\_\_ TDH \_\_\_\_\_

CERTIFIED: \_\_\_\_\_ DATE: \_\_\_\_\_

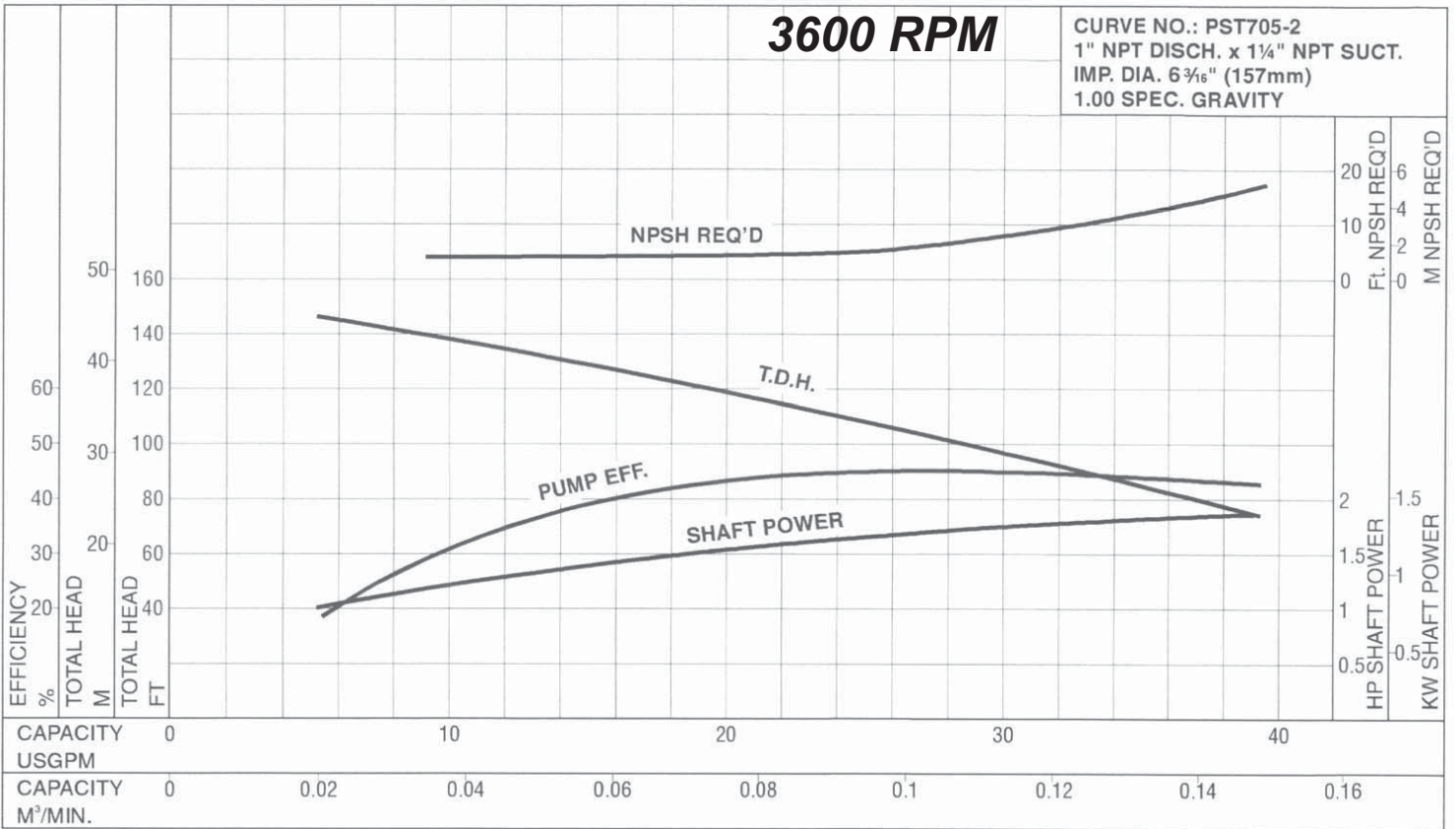





Series PS **MODEL PST1201**

CUSTOMER \_\_\_\_\_ REFERENCE \_\_\_\_\_

FLUID \_\_\_\_\_ S.G. \_\_\_\_\_ TEMP \_\_\_\_\_ CAPACITY \_\_\_\_\_ TDH \_\_\_\_\_

CERTIFIED: \_\_\_\_\_ DATE: \_\_\_\_\_

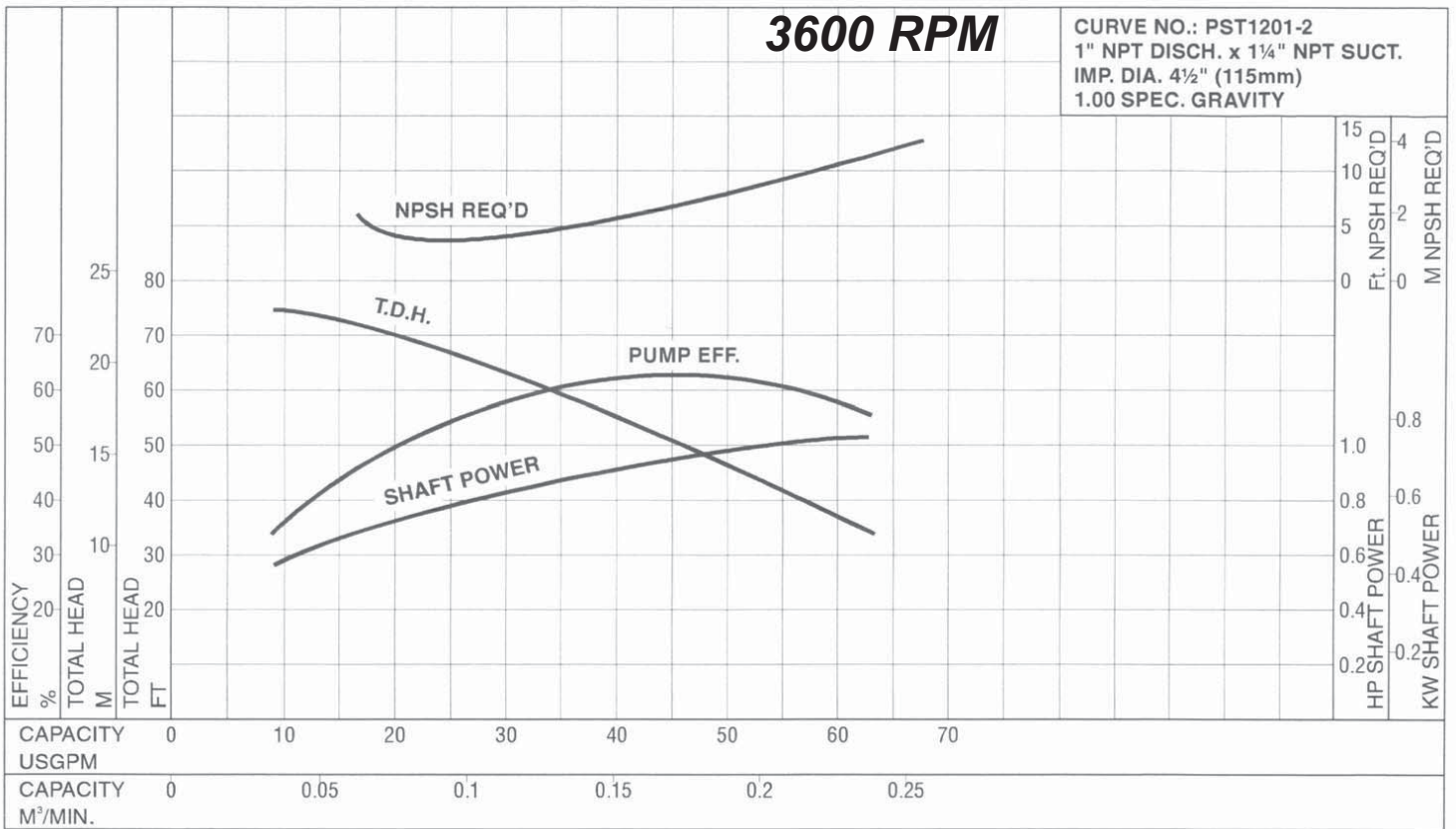



Series PS **MODEL PST1203**

CUSTOMER \_\_\_\_\_ REFERENCE \_\_\_\_\_

FLUID \_\_\_\_\_ S.G. \_\_\_\_\_ TEMP \_\_\_\_\_ CAPACITY \_\_\_\_\_ TDH \_\_\_\_\_

CERTIFIED: \_\_\_\_\_ DATE: \_\_\_\_\_

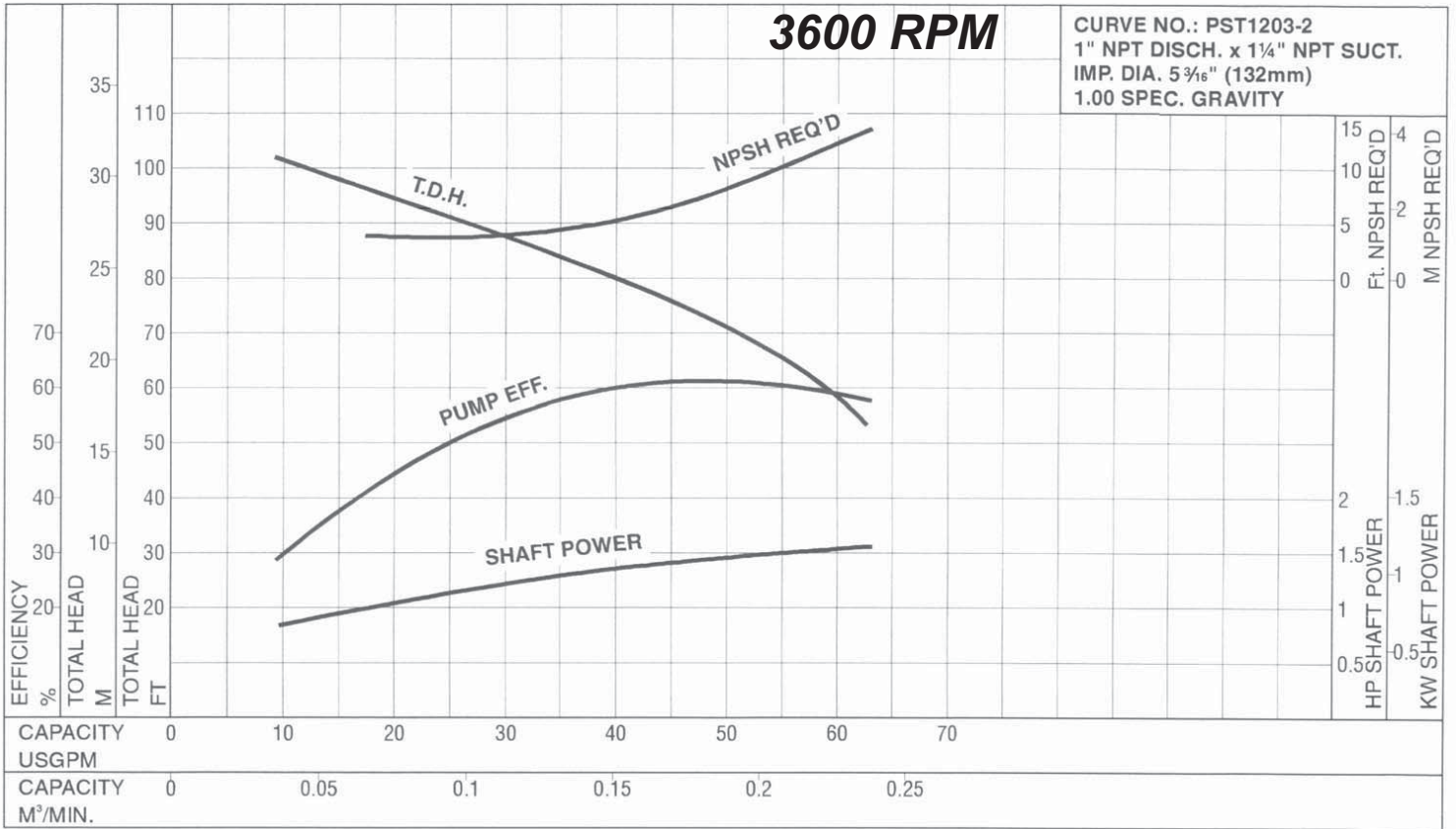



Series PS **MODEL PST1205**

CUSTOMER \_\_\_\_\_ REFERENCE \_\_\_\_\_

FLUID \_\_\_\_\_ S.G. \_\_\_\_\_ TEMP \_\_\_\_\_ CAPACITY \_\_\_\_\_ TDH \_\_\_\_\_

CERTIFIED: \_\_\_\_\_ DATE: \_\_\_\_\_

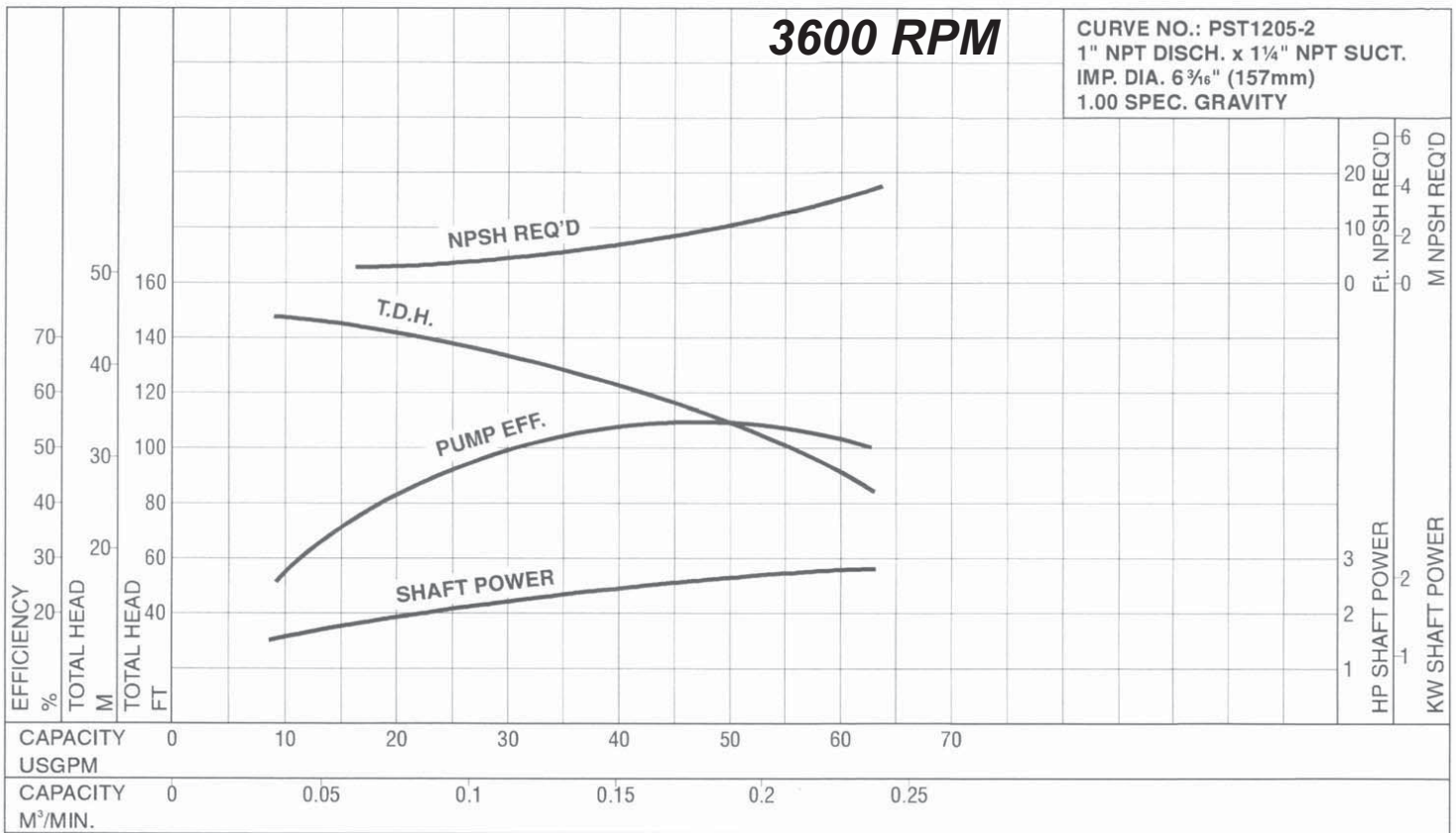



Series PS **MODEL PST2001**

CUSTOMER \_\_\_\_\_ REFERENCE \_\_\_\_\_

FLUID \_\_\_\_\_ S.G. \_\_\_\_\_ TEMP \_\_\_\_\_ CAPACITY \_\_\_\_\_ TDH \_\_\_\_\_

CERTIFIED: \_\_\_\_\_ DATE: \_\_\_\_\_

**3600 RPM**

CURVE NO.: PST2001-2  
 1" NPT DISCH. x 1½" NPT SUCT.  
 IMP. DIA. 4½" (115mm)  
 1.00 SPEC. GRAVITY

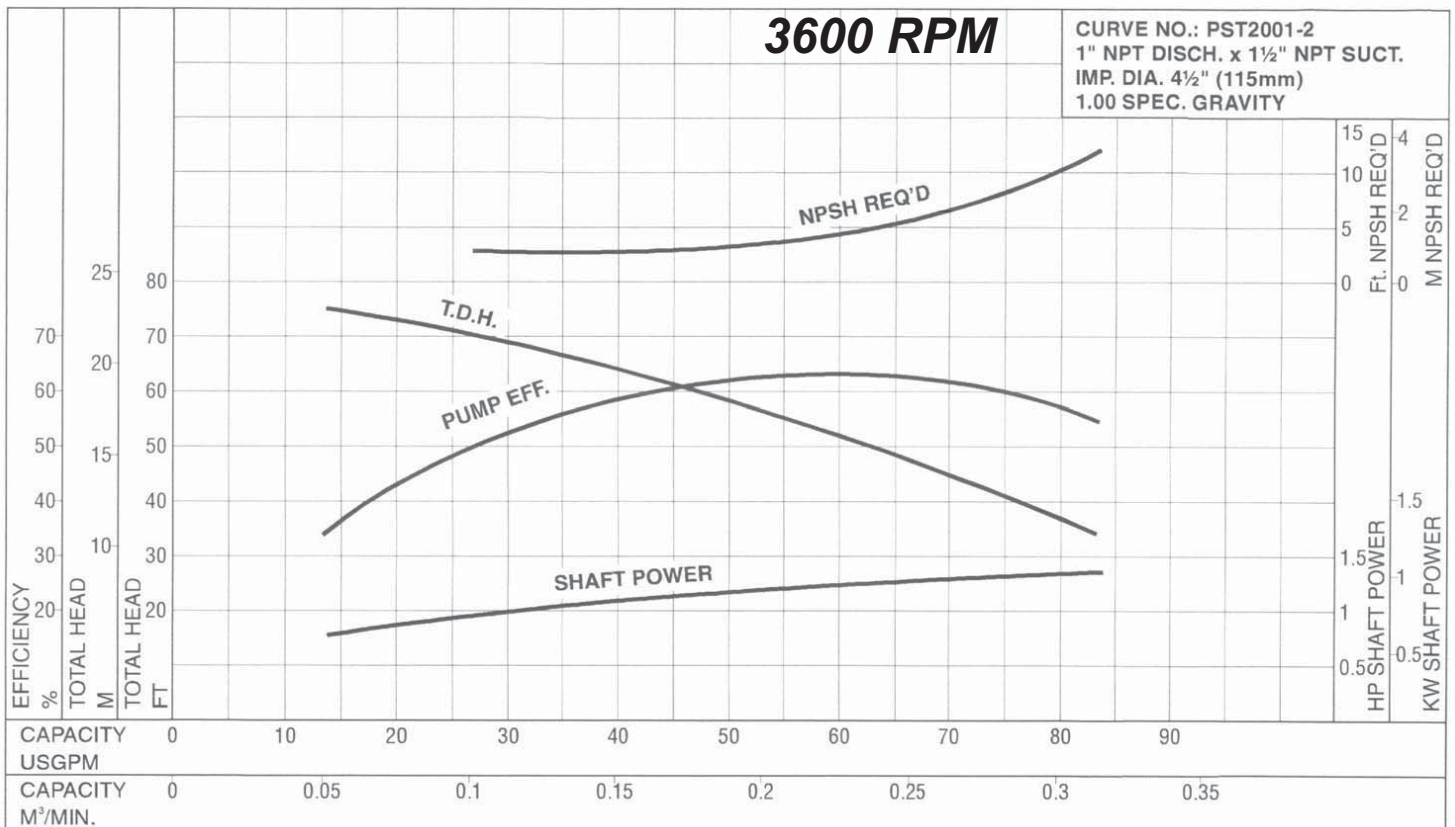





Series PS **MODEL PST2003**

CUSTOMER \_\_\_\_\_ REFERENCE \_\_\_\_\_

FLUID \_\_\_\_\_ S.G. \_\_\_\_\_ TEMP \_\_\_\_\_ CAPACITY \_\_\_\_\_ TDH \_\_\_\_\_

CERTIFIED: \_\_\_\_\_ DATE: \_\_\_\_\_

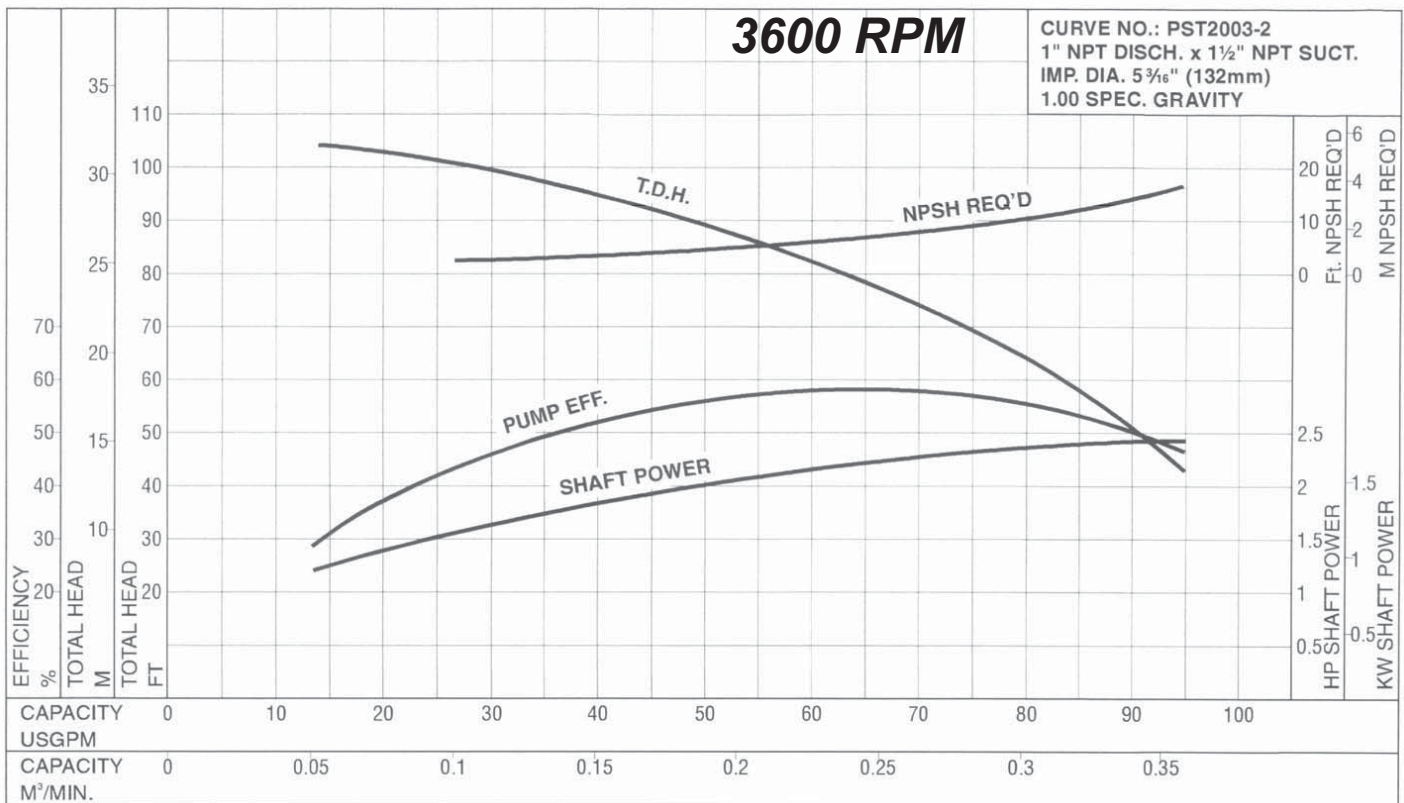



Series PS **MODEL PST2005**

CUSTOMER \_\_\_\_\_ REFERENCE \_\_\_\_\_

FLUID \_\_\_\_\_ S.G. \_\_\_\_\_ TEMP \_\_\_\_\_ CAPACITY \_\_\_\_\_ TDH \_\_\_\_\_

CERTIFIED: \_\_\_\_\_ DATE: \_\_\_\_\_

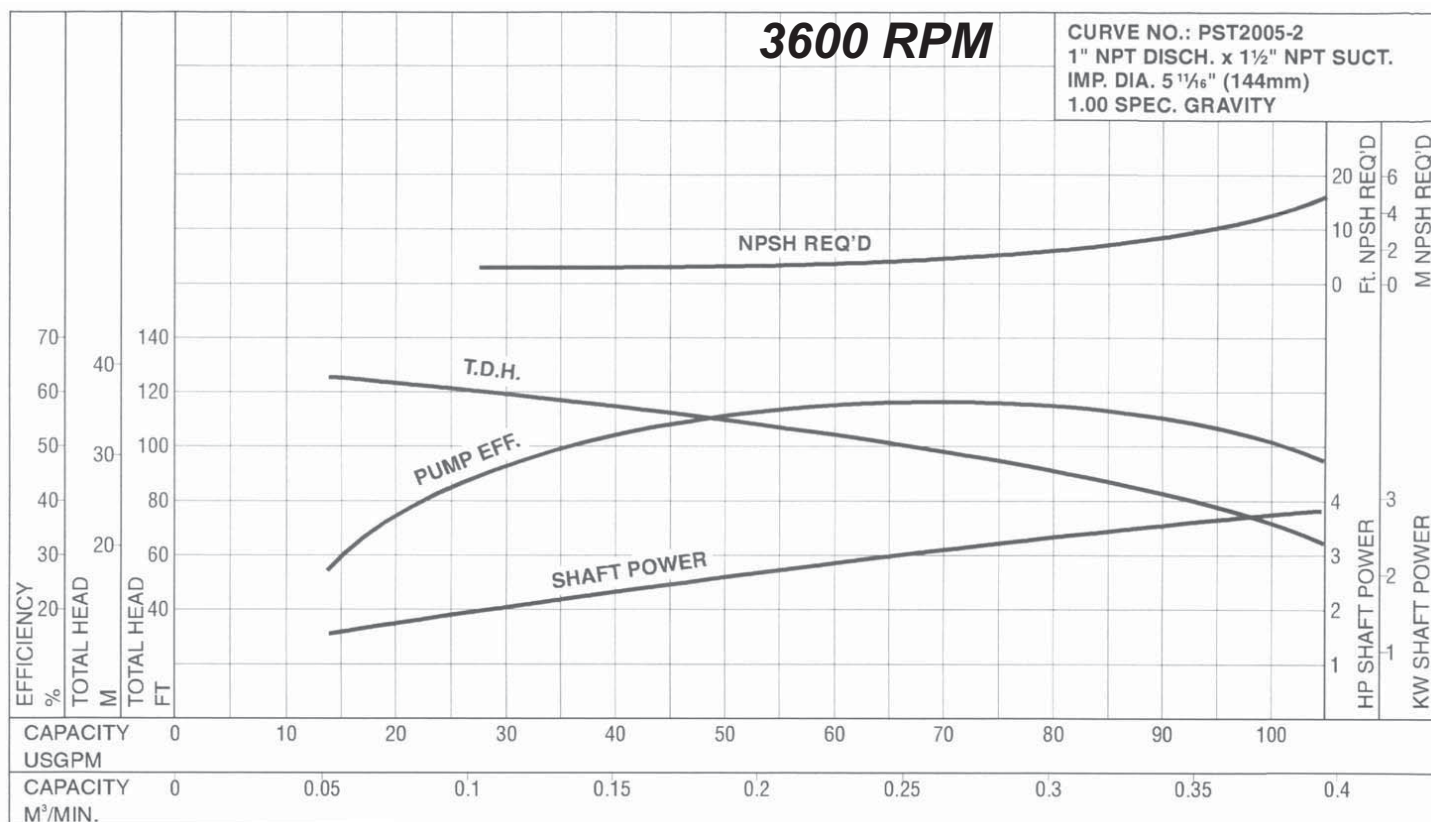

# FLOFAB

## SERIES PS Parts List MODEL - PST701

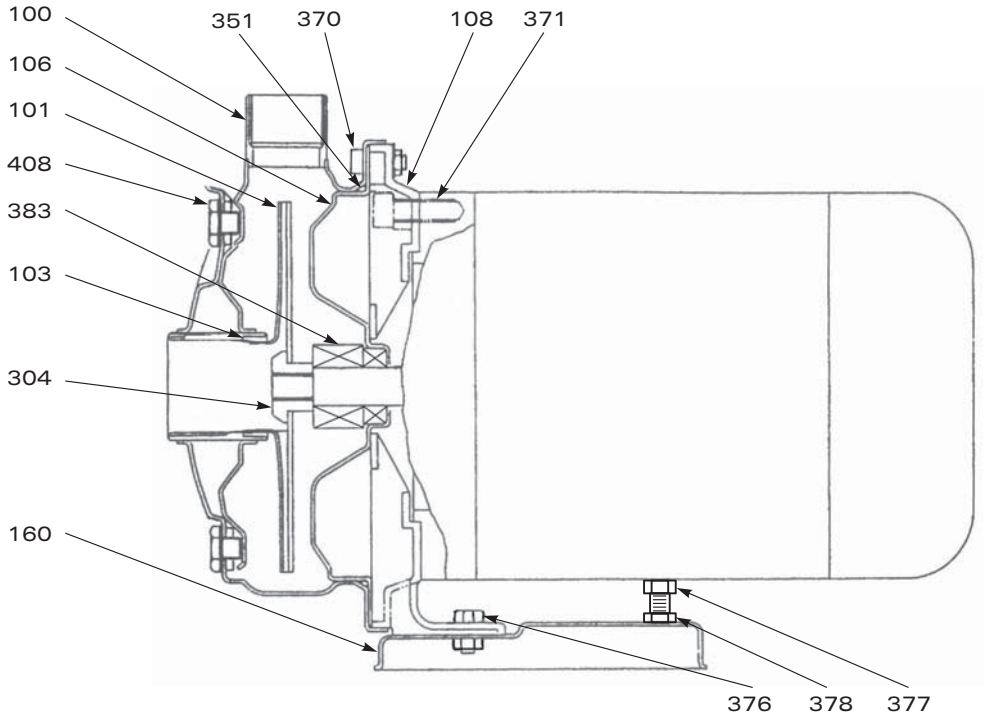

ITEM	QTY REQ'D	DESCRIPTION	MATERIAL	PART NUMBER
100	1	Casing	304 Stainless steel	E-251402230
101	1	Impeller	304 Stainless steel	E-251450785
103	1	Casing ring	Viton	E-255402064
106	1	Casing cover	304 Stainless steel	E-251438016
108	1	Adapter	Aluminum	E-340280085
160	1	Motor support	Steel	E-371472072
304	1	Impeller nut	304 Stainless steel	E-363396101
351	1	Casing o-ring	Viton (standard)	E-165X3V
			Buna (optional)	E-165X3B
370	8	Casing bolt	304 Stainless steel	E-M6X16HH
371	4	Motor bolt	Steel	E-3/8-16X3/4SH
376	2	Foot bolt	Steel	E-M8X16HH
377	1	Support bolt	Steel	E-M8X45HH
378	1	Support bolt nut	Steel	E-M8HN
383	1	Mechanical seal	Carbon/Ceramic/Buna	S10-2021-ABN
			Carbon/Ceramic/Viton	S10-2021-AVT
			Carbon/S.S./EPR	S10-2021-CEP
			Carbon/Carbide/Viton	S10-2021-BVT
			Carbide/Carbide/Viton	S10-2021-EVT
408	2	Casing plug	304 Stainless steel	375132107



**SERIES PS**  
**Parts List**  
**MODEL - PST703**

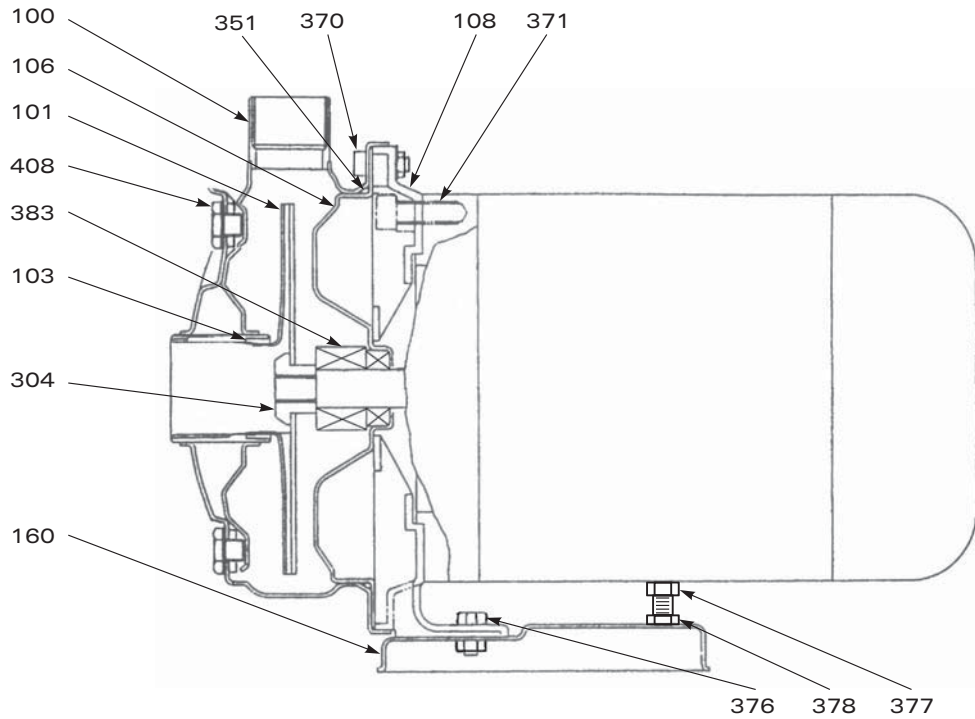

ITEM	QTY REQ'D	DESCRIPTION	MATERIAL	PART NUMBER
100	1	Casing	304 Stainless steel	E-251402230
101	1	Impeller	304 Stainless steel	E-251450786
103	1	Casing ring	Viton	E-255402064
106	1	Casing cover	304 Stainless steel	E-251438016
108	1	Adapter	Aluminum	E-340280085
160	1	Motor support	Steel	E-371472072
304	1	Impeller nut	304 Stainless steel	E-363396101
351	1	Casing o-ring	Viton (standard)	E-165X3V
			Buna (optional)	E-165X3B
370	8	Casing bolt	304 Stainless steel	E-M6X16HH
371	4	Motor bolt	Steel	E-3/8-16X3/4SH
376	2	Foot bolt	Steel	E-M8X16HH
377	1	Support bolt	Steel	E-M8X45HH
378	1	Support bolt nut	Steel	E-M8HN
383	1	Mechanical seal	Carbon/Ceramic/Buna	S10-2021-ABN
			Carbon/Ceramic/Viton	S10-2021-AVT
			Carbon/S.S./EPR	S10-2021-CEP
			Carbon/Carbide/Viton	S10-2021-BVT
			Carbide/Carbide/Viton	S10-2021-EVT
408	2	Casing plug	304 Stainless steel	375132107



# FLOFAB

## SERIES PS Parts List MODEL - PST705

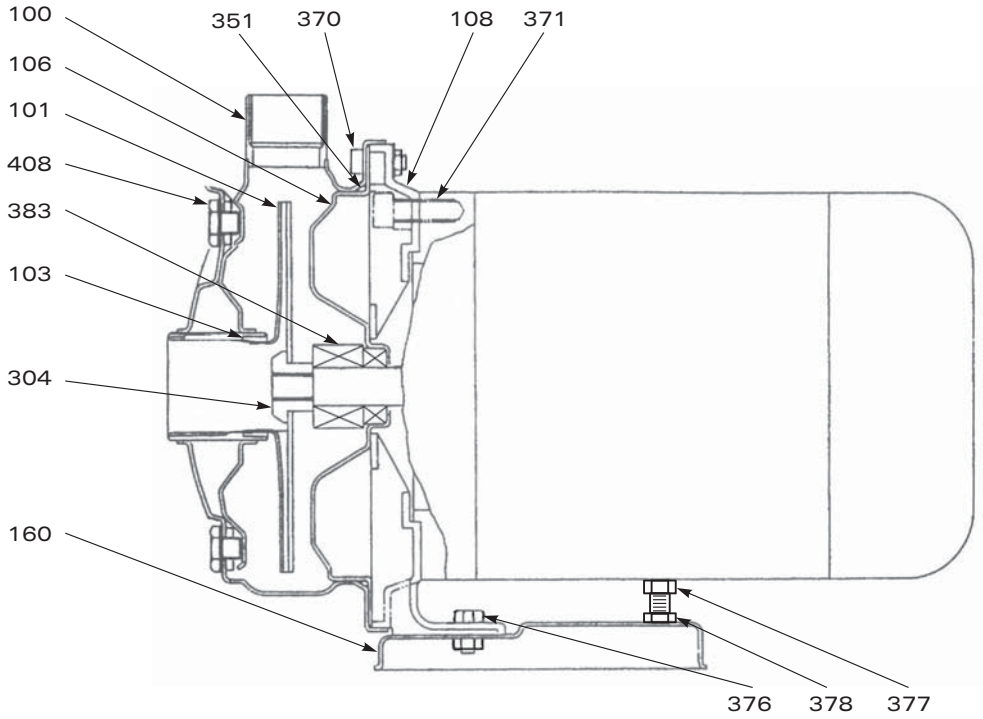

ITEM	QTY REQ'D	DESCRIPTION	MATERIAL	PART NUMBER
100	1	Casing	304 Stainless steel	E-251402230
101	1	Impeller	304 Stainless steel	E-251450787
103	1	Casing ring	Viton	E-255402064
106	1	Casing cover	304 Stainless steel	E-251438016
108	1	Adapter	Aluminum	E-340280085
160	1	Motor support	Steel	E-371472072
304	1	Impeller nut	304 Stainless steel	E-363396101
351	1	Casing o-ring	Viton (standard) Buna (optional)	E-165X3V E-165X3B
370	8	Casing bolt	304 Stainless steel	E-M6X16HH
371	4	Motor bolt	Steel	E-3/8-16X3/4SH
376	2	Foot bolt	Steel	E-M8X16HH
377	1	Support bolt	Steel	E-M8X45HH
378	1	Support bolt nut	Steel	E-M8HN
383	1	Mechanical seal	Carbon/Ceramic/Buna Carbon/Ceramic/Viton Carbon/S.S./EPR Carbon/Carbide/Viton Carbide/Carbide/Viton	S10-2021-ABN S10-2021-AVT S10-2021-CEP S10-2021-BVT S10-2021-EVT
408	2	Casing plug	304 Stainless steel	375132107

# FLOFAB

## SERIES PS Parts List MODEL - PST1201

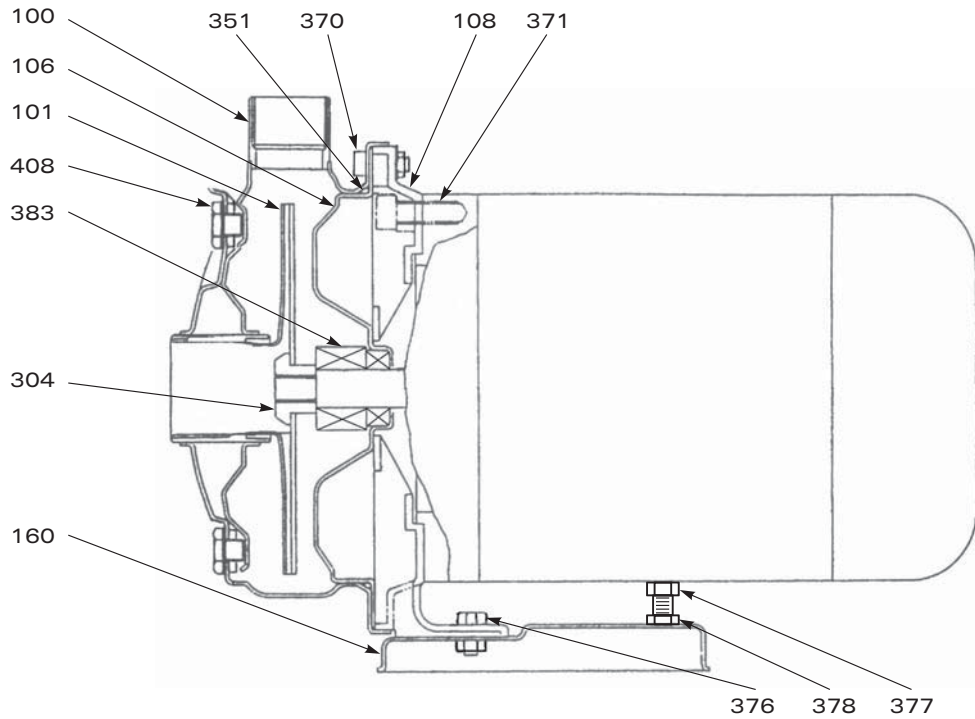

ITEM	QTY REQ'D	DESCRIPTION	MATERIAL	PART NUMBER
100	1	Casing	304 Stainless steel	E-251402231
101	1	Impeller	304 Stainless steel	E-251450788
106	1	Casing cover	304 Stainless steel	E-251438016
108	1	Adapter	Aluminum	E-340280085
160	1	Motor support	Steel	E-371472072
304	1	Impeller nut	304 Stainless steel	E-363396101
351	1	Casing o-ring	Viton (standard)	E-165X3V
			Buna (optional)	E-165X3B
370	8	Casing bolt	304 Stainless steel	E-M6X16HH
371	4	Motor bolt	Steel	E-3/8-16X3/4SH
376	2	Foot bolt	Steel	E-M8X16HH
377	1	Support bolt	Steel	E-M8X45HH
378	1	Support bolt nut	Steel	E-M8HN
383	1	Mechanical seal	Carbon/Ceramic/Buna	S10-2021-ABN
			Carbon/Ceramic/Viton	S10-2021-AVT
			Carbon/S.S./EPR	S10-2021-CEP
			Carbon/Carbide/Viton	S10-2021-BVT
			Carbide/Carbide/Viton	S10-2021-EVT
408	2	Casing plug	304 Stainless steel	375132107

# FLOFAB

## SERIES PS Parts List MODEL - PST1203

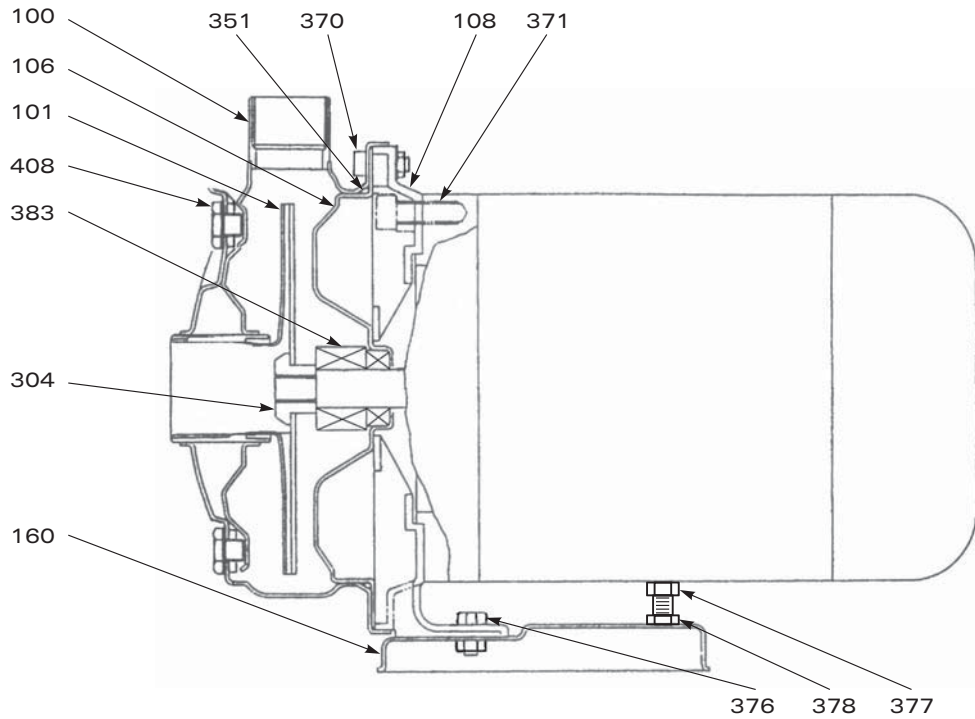

ITEM	QTY REQ'D	DESCRIPTION	MATERIAL	PART NUMBER
100	1	Casing	304 Stainless steel	E-251402231
101	1	Impeller	304 Stainless steel	E-251450789
106	1	Casing cover	304 Stainless steel	E-251438016
108	1	Adapter	Aluminum	E-340280085
160	1	Motor support	Steel	E-371472072
304	1	Impeller nut	304 Stainless steel	E-363396101
351	1	Casing o-ring	Viton (standard)	E-165X3V
			Buna (optional)	E-165X3B
370	8	Casing bolt	304 Stainless steel	E-M6X16HH
371	4	Motor bolt	Steel	E-3/8-16X3/4SH
376	2	Foot bolt	Steel	E-M8X16HH
377	1	Support bolt	Steel	E-M8X45HH
378	1	Support bolt nut	Steel	E-M8HN
383	1	Mechanical seal	Carbon/Ceramic/Buna	S10-2021-ABN
			Carbon/Ceramic/Viton	S10-2021-AVT
			Carbon/S.S./EPR	S10-2021-CEP
			Carbon/Carbide/Viton	S10-2021-BVT
			Carbide/Carbide/Viton	S10-2021-EVT
408	2	Casing plug	304 Stainless steel	375132107



**SERIES PS**  
**Parts List**  
**MODEL - PST1205**

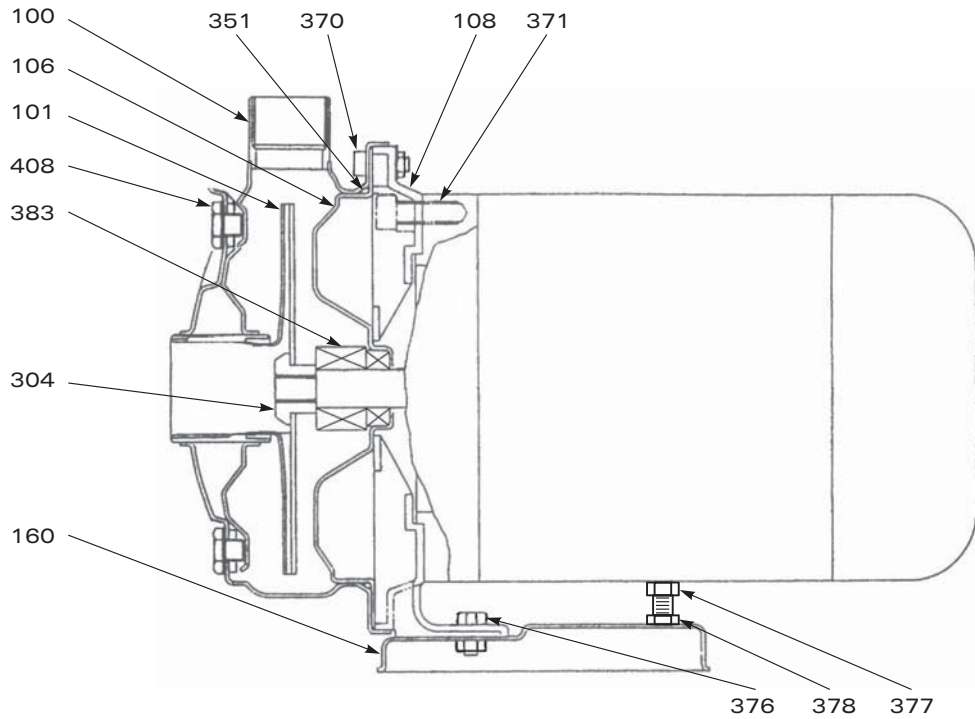

ITEM	QTY REQ'D	DESCRIPTION	MATERIAL	PART NUMBER
100	1	Casing	304 Stainless steel	E-251420086
101	1	Impeller	304 Stainless steel	E-251450790
106	1	Casing cover	304 Stainless steel	E-251438016
108	1	Adapter	Aluminum	E-340280085
160	1	Motor support	Steel	E-371472072
304	1	Impeller nut	304 Stainless steel	E-363396101
351	1	Casing o-ring	Viton (standard)	E-165X3V
			Buna (optional)	E-165X3B
370	8	Casing bolt	304 Stainless steel	E-M6X16HH
371	4	Motor bolt	Steel	E-3/8-16X3/4SH
376	2	Foot bolt	Steel	E-M8X16HH
377	1	Support bolt	Steel	E-M8X45HH
378	1	Support bolt nut	Steel	E-M8HN
383	1	Mechanical seal	Carbon/Ceramic/Buna	S10-2021-ABN
			Carbon/Ceramic/Viton	S10-2021-AVT
			Carbon/S.S./EPR	S10-2021-CEP
			Carbon/Carbide/Viton	S10-2021-BVT
			Carbide/Carbide/Viton	S10-2021-EVT
408	2	Casing plug	304 Stainless steel	375132107

# FLOFAB

## SERIES PS Parts List MODEL - PST2001

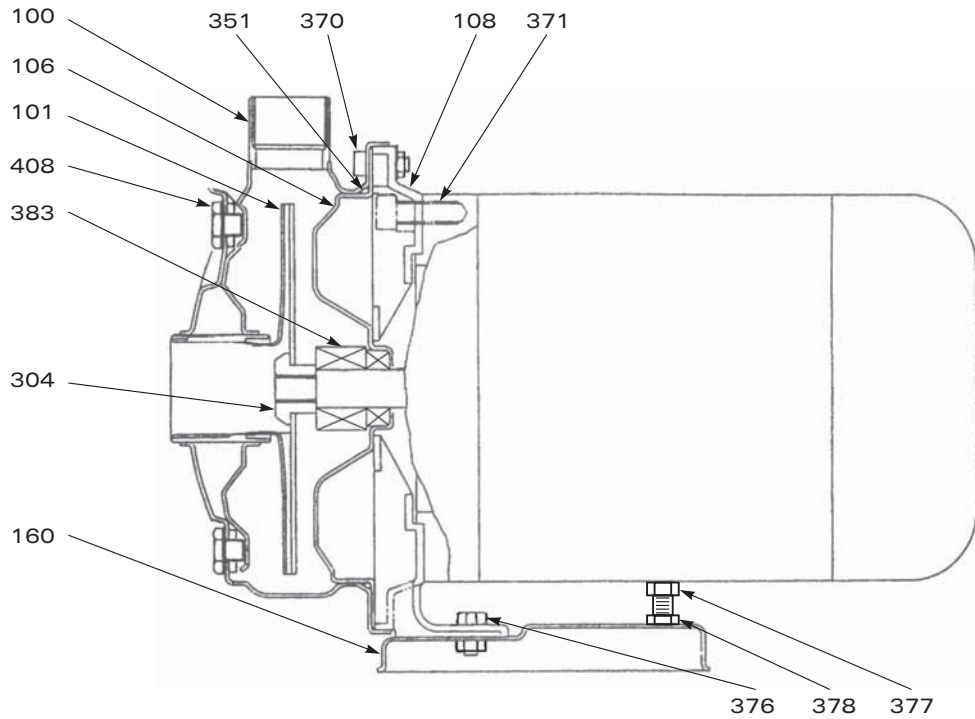

ITEM	QTY REQ'D	DESCRIPTION	MATERIAL	PART NUMBER
100	1	Casing	304 Stainless steel	E-251420087
101	1	Impeller	304 Stainless steel	E-251450791
106	1	Casing cover	304 Stainless steel	E-251438016
108	1	Adapter	Aluminum	E-340280085
160	1	Motor support	Steel	E-371472072
304	1	Impeller nut	304 Stainless steel	E-363396101
351	1	Casing o-ring	Viton (standard)	E-165X3V
			Buna (optional)	E-165X3B
370	8	Casing bolt	304 Stainless steel	E-M6X16HH
371	4	Motor bolt	Steel	E-3/8-16X3/4SH
376	2	Foot bolt	Steel	E-M8X16HH
377	1	Support bolt	Steel	E-M8X45HH
378	1	Support bolt nut	Steel	E-M8HN
383	1	Mechanical seal	Carbon/Ceramic/Buna	S10-2021-ABN
			Carbon/Ceramic/Viton	S10-2021-AVT
			Carbon/S.S./EPR	S10-2021-CEP
			Carbon/Carbide/Viton	S10-2021-BVT
			Carbide/Carbide/Viton	S10-2021-EVT
408	2	Casing plug	304 Stainless steel	375132107



**SERIES PS**  
**Parts List**  
**MODEL - PST2003**

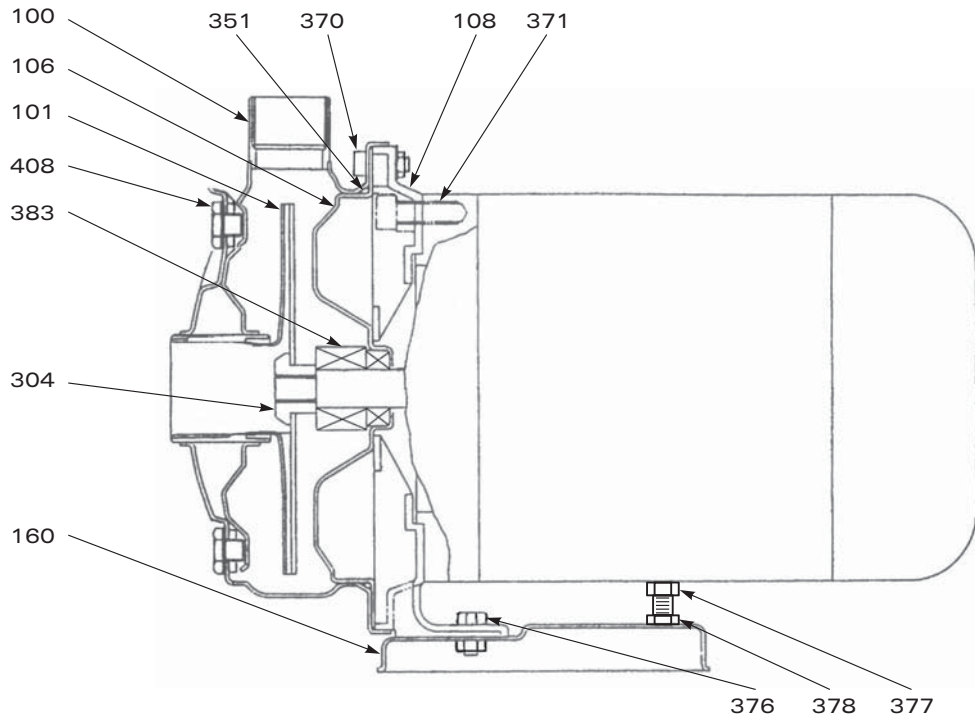

ITEM	QTY REQ'D	DESCRIPTION	MATERIAL	PART NUMBER
100	1	Casing	304 Stainless steel	E-251420087
101	1	Impeller	304 Stainless steel	E-251450792
106	1	Casing cover	304 Stainless steel	E-251438016
108	1	Adapter	Aluminum	E-340280085
160	1	Motor support	Steel	E-371472072
304	1	Impeller nut	304 Stainless steel	E-363396101
351	1	Casing o-ring	Viton (standard)	E-165X3V
			Buna (optional)	E-165X3B
370	8	Casing bolt	304 Stainless steel	E-M6X16HH
371	4	Motor bolt	Steel	E-3/8-16X3/4SH
376	2	Foot bolt	Steel	E-M8X16HH
377	1	Support bolt	Steel	E-M8X45HH
378	1	Support bolt nut	Steel	E-M8HN
383	1	Mechanical seal	Carbon/Ceramic/Buna	S10-2021-ABN
			Carbon/Ceramic/Viton	S10-2021-AVT
			Carbon/S.S./EPR	S10-2021-CEP
			Carbon/Carbide/Viton	S10-2021-BVT
			Carbide/Carbide/Viton	S10-2021-EVT
408	2	Casing plug	304 Stainless steel	375132107



# FLOFAB

## SERIES PS Parts List MODEL - PST2005

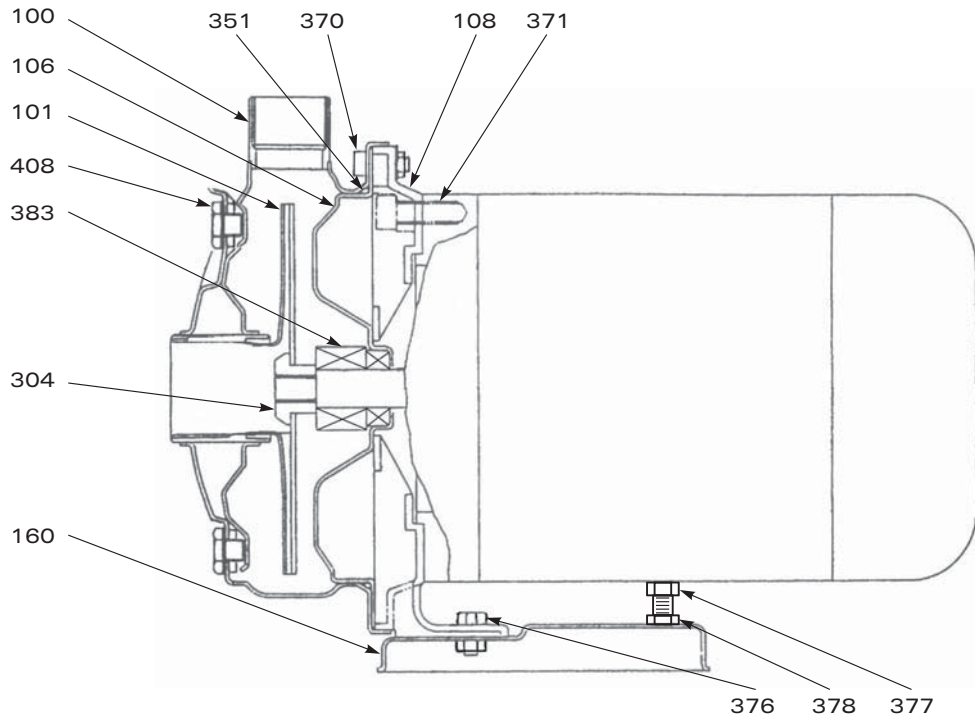

ITEM	QTY REQ'D	DESCRIPTION	MATERIAL	PART NUMBER
100	1	Casing	304 Stainless steel	E-251420087
101	1	Impeller	304 Stainless steel	E-251450793
106	1	Casing cover	304 Stainless steel	E-251438016
108	1	Adapter	Aluminum	E-340280085
160	1	Motor support	Steel	E-371472072
304	1	Impeller nut	304 Stainless steel	E-363396101
351	1	Casing o-ring	Viton (standard)	E-165X3V
			Buna (optional)	E-165X3B
370	8	Casing bolt	304 Stainless steel	E-M6X16HH
371	4	Motor bolt	Steel	E-3/8-16X3/4SH
376	2	Foot bolt	Steel	E-M8X16HH
377	1	Support bolt	Steel	E-M8X45HH
378	1	Support bolt nut	Steel	E-M8HN
383	1	Mechanical seal	Carbon/Ceramic/Buna	S10-2021-ABN
			Carbon/Ceramic/Viton	S10-2021-AVT
			Carbon/S.S./EPR	S10-2021-CEP
			Carbon/Carbide/Viton	S10-2021-BVT
			Carbide/Carbide/Viton	S10-2021-EVT
408	2	Casing plug	304 Stainless steel	375132107

# FLOFAB

## SERIES PS Dimensional Outline MODEL - PST

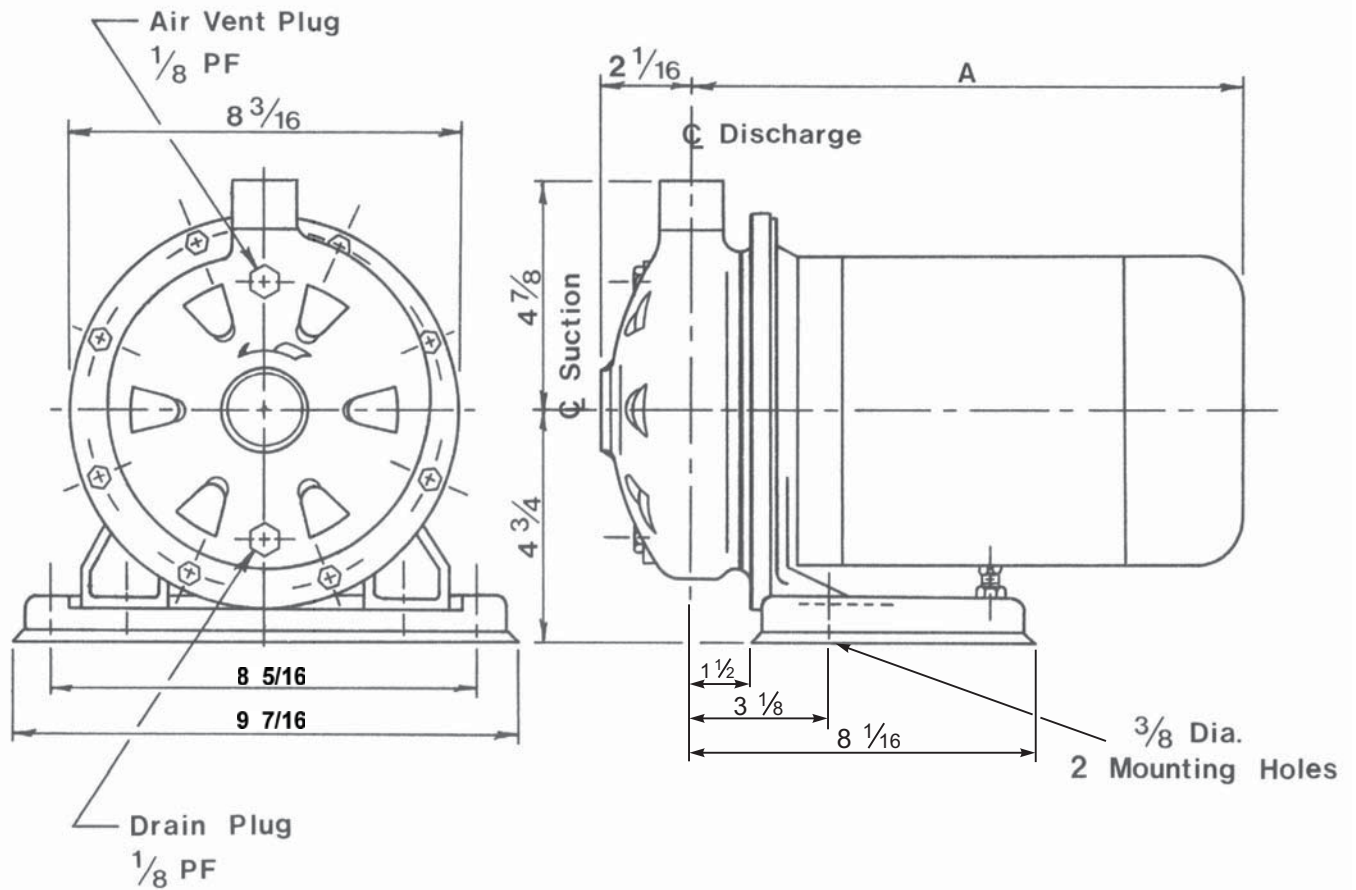

Inches

Model	Size	Pump Size - NPT (in)		A (max.)	Unit Weight (lbs)			
		Suction	Discharge		Single Phase		Three Phase	
					ODP	TEFC	ODP	TEFC
701 $\frac{3}{4}$ HP	1 x $1 \frac{1}{4}$ - $4 \frac{1}{2}$	$1 \frac{1}{4}$	1	$13 \frac{7}{8}$	36	41	31	31
703 $1 \frac{1}{2}$ HP	1 x $1 \frac{1}{4}$ - $5 \frac{3}{16}$	$1 \frac{1}{4}$	1	$13 \frac{9}{16}$	47	50	39	39
705 2HP	1 x $1 \frac{1}{4}$ - $6 \frac{3}{16}$	$1 \frac{1}{4}$	1	$14 \frac{7}{16}$	51	58	44	48
1201 1HP	1 x $1 \frac{1}{4}$ - $4 \frac{1}{2}$	$1 \frac{1}{4}$	1	$13 \frac{9}{16}$	41	46	33	32
1203 $1 \frac{1}{2}$ HP	1 x $1 \frac{1}{4}$ - $5 \frac{3}{16}$	$1 \frac{1}{4}$	1	$13 \frac{9}{16}$	47	50	39	39
1205 3HP	1 x $1 \frac{1}{4}$ - $6 \frac{3}{16}$	$1 \frac{1}{4}$	1	$14 \frac{7}{16}$	59	66	51	60
2001 $1 \frac{1}{2}$ HP	1 x $1 \frac{1}{2}$ - $4 \frac{1}{2}$	$1 \frac{1}{2}$	1	$13 \frac{9}{16}$	47	50	39	39
2003 3HP	1 x $1 \frac{1}{2}$ - $5 \frac{3}{16}$	$1 \frac{1}{2}$	1	$14 \frac{7}{16}$	58	65	50	59
2005 3HP	1 x $1 \frac{1}{2}$ - $5 \frac{11}{16}$	$1 \frac{1}{2}$	1	$14 \frac{7}{16}$	58	65	50	59

NOT FOR CONSTRUCTION PURPOSES UNLESS CERTIFIED.



**SERIES PS - DIMENSIONAL OUTLINE  
MODEL - PST701**

CUSTOMER - \_\_\_\_\_  
 CUSTOMER REF. - \_\_\_\_\_ OUR REF. - \_\_\_\_\_  
 HP - \_\_\_\_\_ RPM - \_\_\_\_\_ VOLTAGE - \_\_\_\_\_ ENCL. - \_\_\_\_\_

CERTIFIED - \_\_\_\_\_ DATE - \_\_\_\_\_

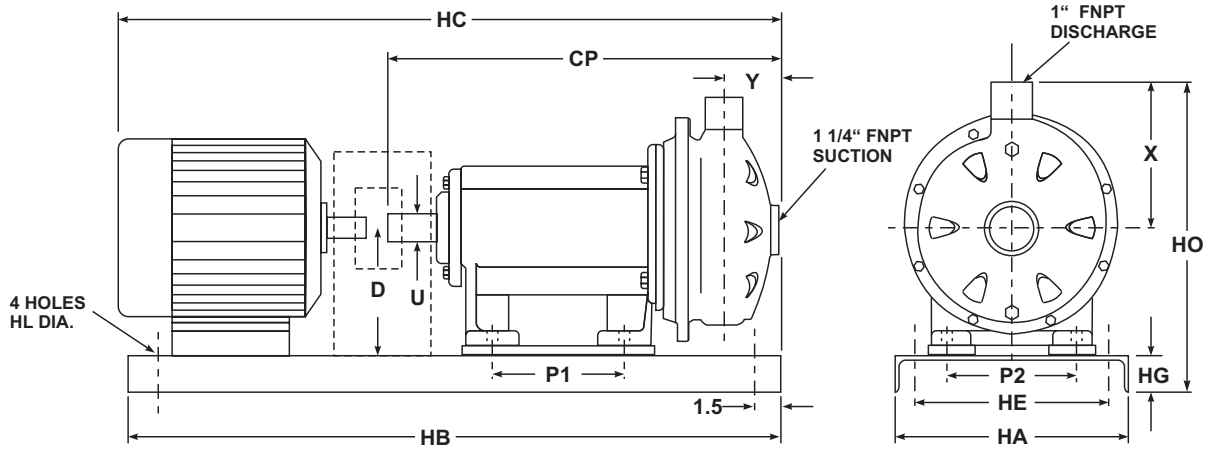

MOTOR FRAME	DIMENSIONS														WEIGHT (lbs)*		
	HA	HB	HL	HC*	HO	HG	HE	CP	P1	P2	D**	U	X	Y	PUMP	MOTOR	ASS'Y
56	10	30	0.62	23	11.75	2.62	7.0	12.12	4.25	5.5	3.68	0.75	4.88	2.06	25	30	95
143T	10	30	0.62	25	11.75	2.62	7.0	12.12	4.25	5.5	3.68	0.75	4.88	2.06	25	40	105
145T	10	30	0.62	26	11.75	2.62	7.0	12.12	4.25	5.5	3.68	0.75	4.88	2.06	25	50	115
182T	10	30	0.62	27	11.75	2.62	7.0	12.12	4.25	5.5	3.68	0.75	4.88	2.06	25	80	150
184T	10	30	0.62	28	11.75	2.62	7.0	12.12	4.25	5.5	3.68	0.75	4.88	2.06	25	90	160

NOTES - Not for construction purposes unless certified above.  
 - All dimensions in inches.  
 - Some dimensions may vary +/- 0.25 inches.  
 - \* Approximate only.  
 - \*\* Shaft centerline to underside of pump feet.



**SERIES PS - DIMENSIONAL OUTLINE  
MODEL - PST703**

CUSTOMER - \_\_\_\_\_  
 CUSTOMER REF. - \_\_\_\_\_ OUR REF. - \_\_\_\_\_  
 HP - \_\_\_\_\_ RPM - \_\_\_\_\_ VOLTAGE - \_\_\_\_\_ ENCL. - \_\_\_\_\_

CERTIFIED - \_\_\_\_\_ DATE - \_\_\_\_\_

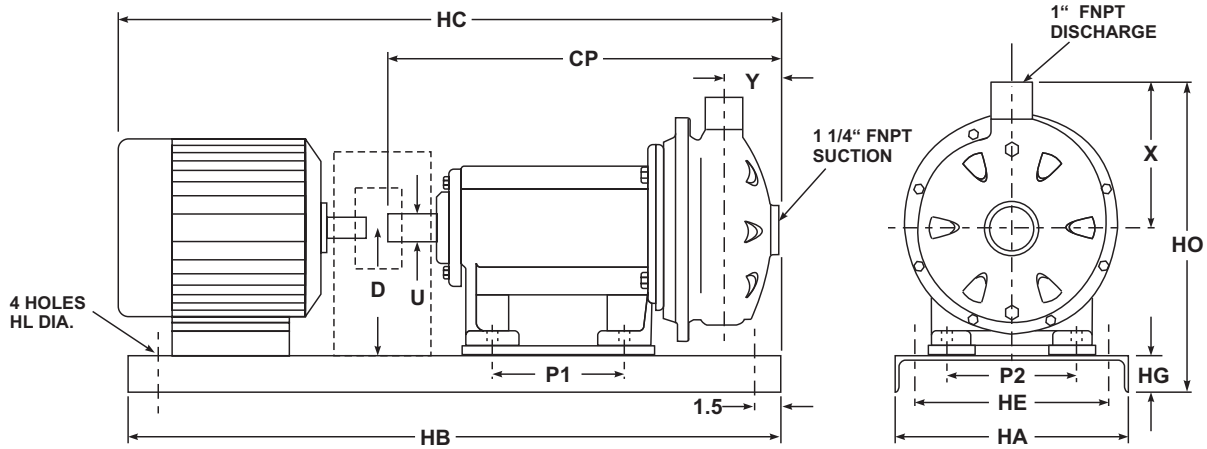

MOTOR FRAME	DIMENSIONS														WEIGHT (lbs)*		
	HA	HB	HL	HC*	HO	HG	HE	CP	P1	P2	D**	U	X	Y	PUMP	MOTOR	ASS'Y
56	10	30	0.62	23	11.75	2.62	7.0	12.12	4.25	5.5	3.68	0.75	4.88	2.06	25	30	95
143T	10	30	0.62	25	11.75	2.62	7.0	12.12	4.25	5.5	3.68	0.75	4.88	2.06	25	40	105
145T	10	30	0.62	26	11.75	2.62	7.0	12.12	4.25	5.5	3.68	0.75	4.88	2.06	25	50	115
182T	10	30	0.62	27	11.75	2.62	7.0	12.12	4.25	5.5	3.68	0.75	4.88	2.06	25	80	150
184T	10	30	0.62	28	11.75	2.62	7.0	12.12	4.25	5.5	3.68	0.75	4.88	2.06	25	90	160

- NOTES - Not for construction purposes unless certified above.  
 - All dimensions in inches.  
 - Some dimensions may vary +/- 0.25 inches.  
 - \* Approximate only.  
 - \*\* Shaft centerline to underside of pump feet.



**SERIES PS - DIMENSIONAL OUTLINE  
MODEL - PST705**

CUSTOMER - \_\_\_\_\_  
 CUSTOMER REF. - \_\_\_\_\_ OUR REF. - \_\_\_\_\_  
 HP - \_\_\_\_\_ RPM - \_\_\_\_\_ VOLTAGE - \_\_\_\_\_ ENCL. - \_\_\_\_\_

CERTIFIED - \_\_\_\_\_ DATE - \_\_\_\_\_

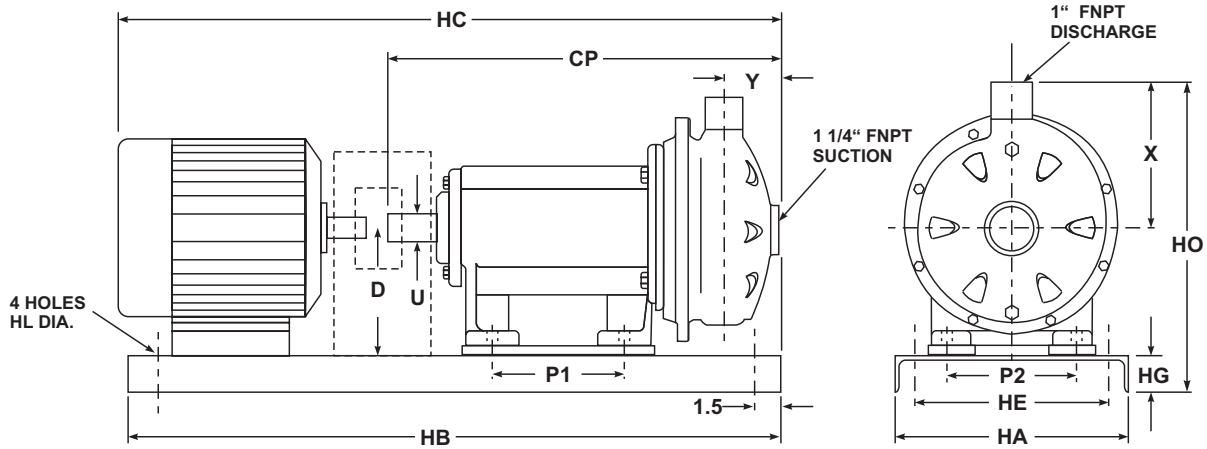

MOTOR FRAME	DIMENSIONS														WEIGHT (lbs)*		
	HA	HB	HL	HC*	HO	HG	HE	CP	P1	P2	D**	U	X	Y	PUMP	MOTOR	ASS'Y
56	10	30	0.62	23	11.75	2.62	7.0	12.12	4.25	5.5	3.68	0.75	4.88	2.06	25	30	95
143T	10	30	0.62	25	11.75	2.62	7.0	12.12	4.25	5.5	3.68	0.75	4.88	2.06	25	40	105
145T	10	30	0.62	26	11.75	2.62	7.0	12.12	4.25	5.5	3.68	0.75	4.88	2.06	25	50	115
182T	10	30	0.62	27	11.75	2.62	7.0	12.12	4.25	5.5	3.68	0.75	4.88	2.06	25	80	150
184T	10	30	0.62	28	11.75	2.62	7.0	12.12	4.25	5.5	3.68	0.75	4.88	2.06	25	90	160

NOTES - Not for construction purposes unless certified above.  
 - All dimensions in inches.  
 - Some dimensions may vary +/- 0.25 inches.  
 - \* Approximate only.  
 - \*\* Shaft centerline to underside of pump feet.



**SERIES PS - DIMENSIONAL OUTLINE  
MODEL - PST1201**

CUSTOMER - \_\_\_\_\_  
 CUSTOMER REF. - \_\_\_\_\_ OUR REF. - \_\_\_\_\_  
 HP - \_\_\_\_\_ RPM - \_\_\_\_\_ VOLTAGE - \_\_\_\_\_ ENCL. - \_\_\_\_\_

CERTIFIED - \_\_\_\_\_ DATE - \_\_\_\_\_

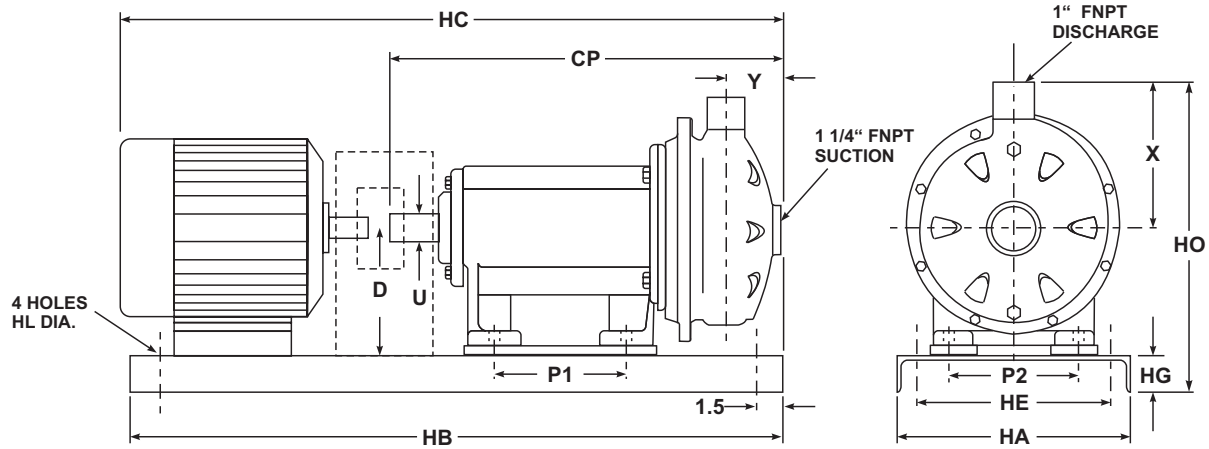

MOTOR FRAME	DIMENSIONS														WEIGHT (lbs)*		
	HA	HB	HL	HC*	HO	HG	HE	CP	P1	P2	D**	U	X	Y	PUMP	MOTOR	ASS'Y
56	10	30	0.62	23	11.75	2.62	7.0	12.12	4.25	5.5	3.68	0.75	4.88	2.06	25	30	95
143T	10	30	0.62	25	11.75	2.62	7.0	12.12	4.25	5.5	3.68	0.75	4.88	2.06	25	40	105
145T	10	30	0.62	26	11.75	2.62	7.0	12.12	4.25	5.5	3.68	0.75	4.88	2.06	25	50	115
182T	10	30	0.62	27	11.75	2.62	7.0	12.12	4.25	5.5	3.68	0.75	4.88	2.06	25	80	150
184T	10	30	0.62	28	11.75	2.62	7.0	12.12	4.25	5.5	3.68	0.75	4.88	2.06	25	90	160

NOTES - Not for construction purposes unless certified above.  
 - All dimensions in inches.  
 - Some dimensions may vary +/- 0.25 inches.  
 - \* Approximate only.  
 - \*\* Shaft centerline to underside of pump feet.





**SERIES PS - DIMENSIONAL OUTLINE  
MODEL - PST1203**

CUSTOMER - \_\_\_\_\_  
 CUSTOMER REF. - \_\_\_\_\_ OUR REF. - \_\_\_\_\_  
 HP - \_\_\_\_\_ RPM - \_\_\_\_\_ VOLTAGE - \_\_\_\_\_ ENCL. - \_\_\_\_\_

CERTIFIED - \_\_\_\_\_ DATE - \_\_\_\_\_

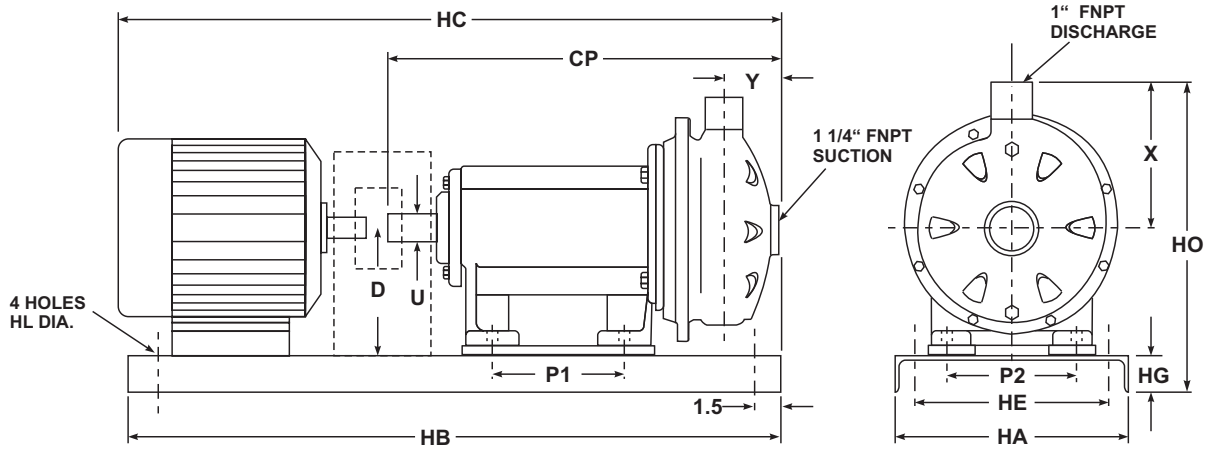

MOTOR FRAME	DIMENSIONS														WEIGHT (lbs)*		
	HA	HB	HL	HC*	HO	HG	HE	CP	P1	P2	D**	U	X	Y	PUMP	MOTOR	ASS'Y
56	10	30	0.62	23	11.75	2.62	7.0	12.12	4.25	5.5	3.68	0.75	4.88	2.06	25	30	95
143T	10	30	0.62	25	11.75	2.62	7.0	12.12	4.25	5.5	3.68	0.75	4.88	2.06	25	40	105
145T	10	30	0.62	26	11.75	2.62	7.0	12.12	4.25	5.5	3.68	0.75	4.88	2.06	25	50	115
182T	10	30	0.62	27	11.75	2.62	7.0	12.12	4.25	5.5	3.68	0.75	4.88	2.06	25	80	150
184T	10	30	0.62	28	11.75	2.62	7.0	12.12	4.25	5.5	3.68	0.75	4.88	2.06	25	90	160

NOTES - Not for construction purposes unless certified above.  
 - All dimensions in inches.  
 - Some dimensions may vary +/- 0.25 inches.  
 - \* Approximate only.  
 - \*\* Shaft centerline to underside of pump feet.



**SERIES PS - DIMENSIONAL OUTLINE  
MODEL - PST1205**

CUSTOMER - \_\_\_\_\_  
 CUSTOMER REF. - \_\_\_\_\_ OUR REF. - \_\_\_\_\_  
 HP - \_\_\_\_\_ RPM - \_\_\_\_\_ VOLTAGE - \_\_\_\_\_ ENCL. - \_\_\_\_\_

CERTIFIED - \_\_\_\_\_ DATE - \_\_\_\_\_

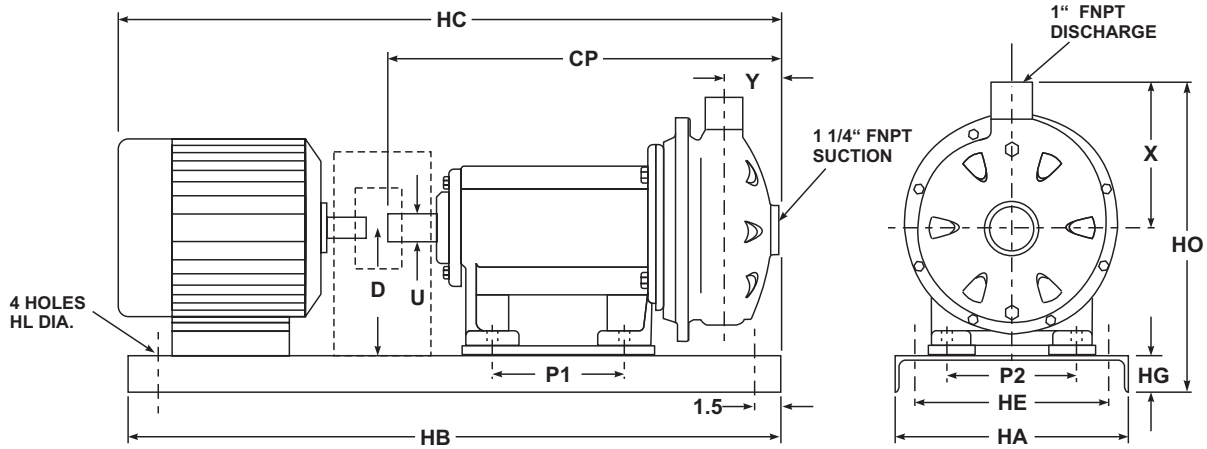

MOTOR FRAME	DIMENSIONS														WEIGHT (lbs)*		
	HA	HB	HL	HC*	HO	HG	HE	CP	P1	P2	D**	U	X	Y	PUMP	MOTOR	ASS'Y
56	10	30	0.62	23	11.75	2.62	7.0	12.12	4.25	5.5	3.68	0.75	4.88	2.06	25	30	95
143T	10	30	0.62	25	11.75	2.62	7.0	12.12	4.25	5.5	3.68	0.75	4.88	2.06	25	40	105
145T	10	30	0.62	26	11.75	2.62	7.0	12.12	4.25	5.5	3.68	0.75	4.88	2.06	25	50	115
182T	10	30	0.62	27	11.75	2.62	7.0	12.12	4.25	5.5	3.68	0.75	4.88	2.06	25	80	150
184T	10	30	0.62	28	11.75	2.62	7.0	12.12	4.25	5.5	3.68	0.75	4.88	2.06	25	90	160

NOTES - Not for construction purposes unless certified above.  
 - All dimensions in inches.  
 - Some dimensions may vary +/- 0.25 inches.  
 - \* Approximate only.  
 - \*\* Shaft centerline to underside of pump feet.



**SERIES PS - DIMENSIONAL OUTLINE  
MODEL - PST2001**

CUSTOMER - \_\_\_\_\_  
 CUSTOMER REF. - \_\_\_\_\_ OUR REF. - \_\_\_\_\_  
 HP - \_\_\_\_\_ RPM - \_\_\_\_\_ VOLTAGE - \_\_\_\_\_ ENCL. - \_\_\_\_\_

CERTIFIED - \_\_\_\_\_ DATE - \_\_\_\_\_

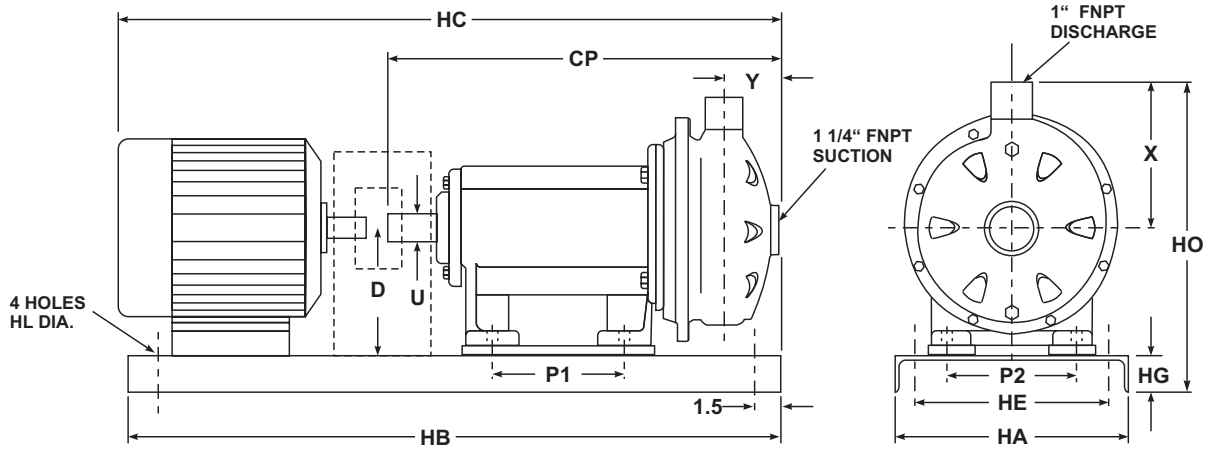

MOTOR FRAME	DIMENSIONS														WEIGHT (lbs)*		
	HA	HB	HL	HC*	HO	HG	HE	CP	P1	P2	D**	U	X	Y	PUMP	MOTOR	ASS'Y
56	10	30	0.62	23	11.75	2.62	7.0	12.12	4.25	5.5	3.68	0.75	4.88	2.06	25	30	95
143T	10	30	0.62	25	11.75	2.62	7.0	12.12	4.25	5.5	3.68	0.75	4.88	2.06	25	40	105
145T	10	30	0.62	26	11.75	2.62	7.0	12.12	4.25	5.5	3.68	0.75	4.88	2.06	25	50	115
182T	10	30	0.62	27	11.75	2.62	7.0	12.12	4.25	5.5	3.68	0.75	4.88	2.06	25	80	150
184T	10	30	0.62	28	11.75	2.62	7.0	12.12	4.25	5.5	3.68	0.75	4.88	2.06	25	90	160

NOTES - Not for construction purposes unless certified above.  
 - All dimensions in inches.  
 - Some dimensions may vary +/- 0.25 inches.  
 - \* Approximate only.  
 - \*\* Shaft centerline to underside of pump feet.



**SERIES PS - DIMENSIONAL OUTLINE  
MODEL - PST2003**

CUSTOMER - \_\_\_\_\_  
 CUSTOMER REF. - \_\_\_\_\_ OUR REF. - \_\_\_\_\_  
 HP - \_\_\_\_\_ RPM - \_\_\_\_\_ VOLTAGE - \_\_\_\_\_ ENCL. - \_\_\_\_\_

CERTIFIED - \_\_\_\_\_ DATE - \_\_\_\_\_

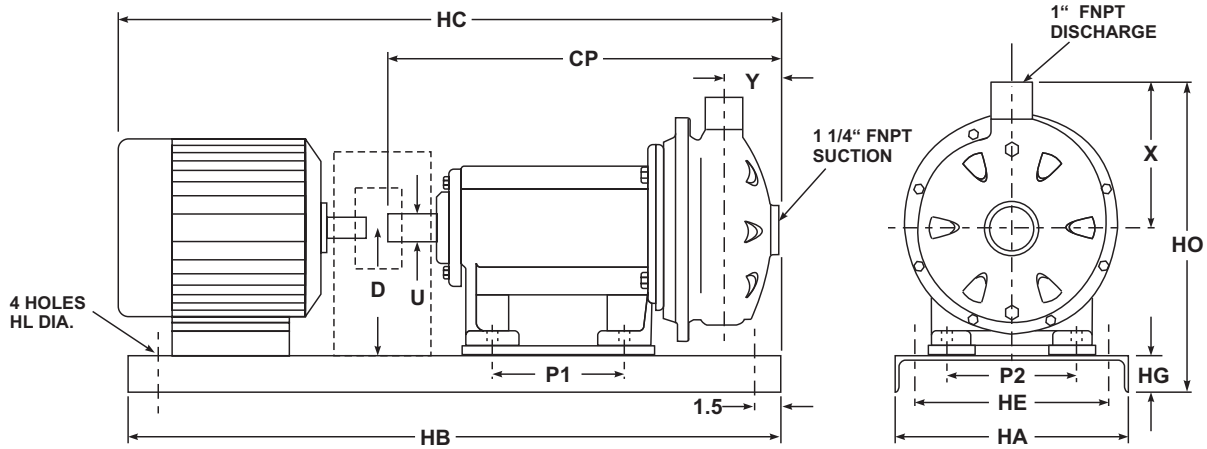

MOTOR FRAME	DIMENSIONS														WEIGHT (lbs)*		
	HA	HB	HL	HC*	HO	HG	HE	CP	P1	P2	D**	U	X	Y	PUMP	MOTOR	ASS'Y
56	10	30	0.62	23	11.75	2.62	7.0	12.12	4.25	5.5	3.68	0.75	4.88	2.06	25	30	95
143T	10	30	0.62	25	11.75	2.62	7.0	12.12	4.25	5.5	3.68	0.75	4.88	2.06	25	40	105
145T	10	30	0.62	26	11.75	2.62	7.0	12.12	4.25	5.5	3.68	0.75	4.88	2.06	25	50	115
182T	10	30	0.62	27	11.75	2.62	7.0	12.12	4.25	5.5	3.68	0.75	4.88	2.06	25	80	150
184T	10	30	0.62	28	11.75	2.62	7.0	12.12	4.25	5.5	3.68	0.75	4.88	2.06	25	90	160

NOTES - Not for construction purposes unless certified above.  
 - All dimensions in inches.  
 - Some dimensions may vary +/- 0.25 inches.  
 - \* Approximate only.  
 - \*\* Shaft centerline to underside of pump feet.



**SERIES PS - DIMENSIONAL OUTLINE  
MODEL - PST2005**

CUSTOMER - \_\_\_\_\_  
 CUSTOMER REF. - \_\_\_\_\_ OUR REF. - \_\_\_\_\_  
 HP - \_\_\_\_\_ RPM - \_\_\_\_\_ VOLTAGE - \_\_\_\_\_ ENCL. - \_\_\_\_\_

CERTIFIED - \_\_\_\_\_ DATE - \_\_\_\_\_

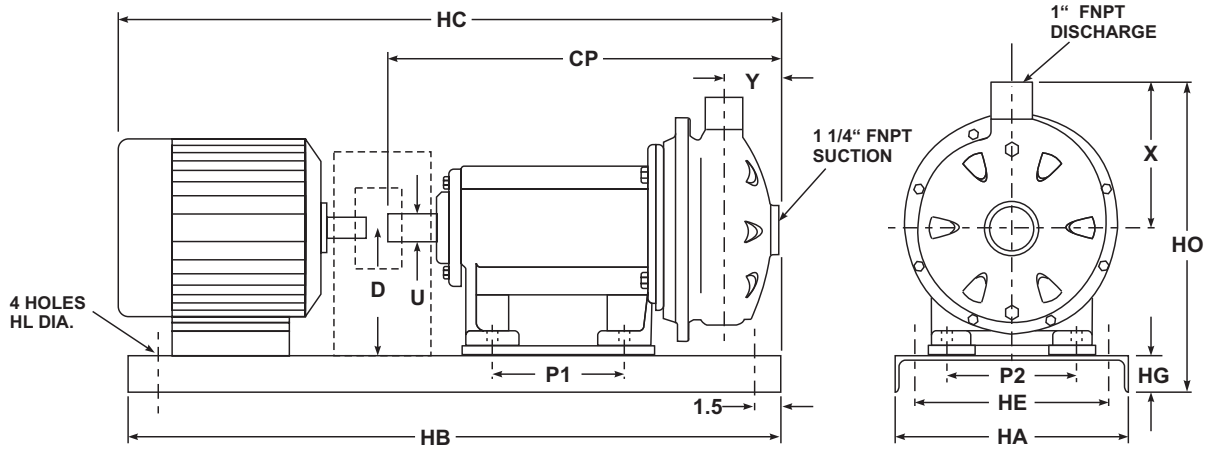

MOTOR FRAME	DIMENSIONS														WEIGHT (lbs)*		
	HA	HB	HL	HC*	HO	HG	HE	CP	P1	P2	D**	U	X	Y	PUMP	MOTOR	ASS'Y
56	10	30	0.62	23	11.75	2.62	7.0	12.12	4.25	5.5	3.68	0.75	4.88	2.06	25	30	95
143T	10	30	0.62	25	11.75	2.62	7.0	12.12	4.25	5.5	3.68	0.75	4.88	2.06	25	40	105
145T	10	30	0.62	26	11.75	2.62	7.0	12.12	4.25	5.5	3.68	0.75	4.88	2.06	25	50	115
182T	10	30	0.62	27	11.75	2.62	7.0	12.12	4.25	5.5	3.68	0.75	4.88	2.06	25	80	150
184T	10	30	0.62	28	11.75	2.62	7.0	12.12	4.25	5.5	3.68	0.75	4.88	2.06	25	90	160

NOTES - Not for construction purposes unless certified above.  
 - All dimensions in inches.  
 - Some dimensions may vary +/- 0.25 inches.  
 - \* Approximate only.  
 - \*\* Shaft centerline to underside of pump feet.



**SERIES PS**  
**Specifications**  
**MODEL - PSF**

	<b>Standard</b>	<b>Optional</b>
<p><b>Size</b></p> <p>Suction (150 lb. ANSI R.F. Equivalent)</p> <p>Discharge (150 lb. ANSI R.F. Equivalent)</p> <p><b>H.P. Range</b></p> <p><b>Performance Range</b></p> <p>Capacity Head</p> <p><b>Liquid Handling</b></p> <p>Liquid Type Temperature</p> <p>Working Pressure</p> <p><b>Materials</b></p> <p>Casing Impeller (Closed Type) Shaft Bracket Mechanical Seal</p> <p><b>Direction of Rotation</b></p> <p><b>Motor</b></p> <p>Type Speed Single Phase</p> <p>Three Phase</p>	<p>PSF70: 2" ANSI PSF120: 2½" ANSI PSF200: 2½" ANSI</p> <p>PSF70: 1¼" ANSI PSF120: 1½" ANSI PSF200: 2" ANSI</p> <p>1 H.P. to 15 H.P.</p> <p>13 to 380 GPM at 3450 R.P.M. 33 to 285 feet at 3450 R.P.M.</p> <p>Various Dependent on Mechanical Seal Selection Max. 145 P.S.I.G. (10 Bar)</p> <p>304 Stainless Steel 304 Stainless Steel Stainless Steel Cast Iron Carbon vs. Ceramic (Buna Elastomers)</p> <p>Clockwise when viewed from motor end</p> <p>NEMA JM Frame 60Hz: 3450 RPM (2 poles) TEFC: 1 H.P. to 10 H.P. ODP: 1 H.P. to 10 H.P. 115/208-230V TEFC: 1 H.P. to 15 H.P. ODP: 1 H.P. to 15 H.P. 208-230/460V and 575V</p>	<p>Various material options for high temperature, corrosive, and abrasive services.</p> <ul style="list-style-type: none"> <li>•Explosion Proof</li> <li>•1750 RPM for lower flows and pressures</li> </ul>



# FLOFAB

## SERIES PS Cross Section **MODEL - PSF** Close-coupled

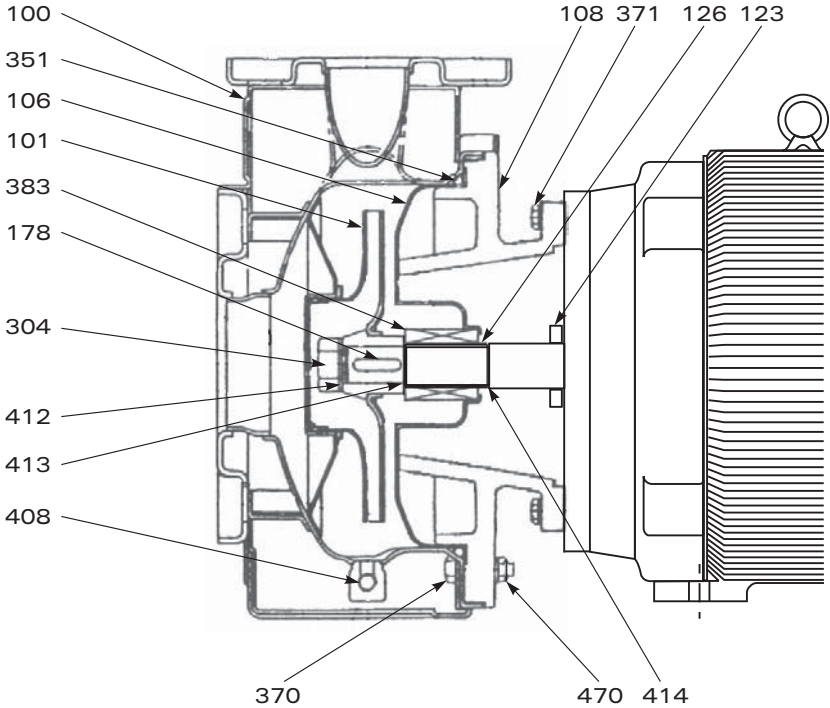

ITEM	QTY REQ'D	DESCRIPTION	MATERIAL
100	1	Casing	304 Stainless steel
101	1	Impeller	304 Stainless steel
106	1	Casing cover	304 Stainless steel
108	1	Adapter	Cast Iron
123	1	Slinger	Rubber
126	1	Shaft sleeve	304 Stainless steel
178	1	Impeller key	Steel
304	1	Impeller bolt	316 SS
351	1	Casing o-ring	Buna (standard)
370	*	Casing bolt	304 Stainless steel
371	4	Motor bolt	Steel
383	1	Mechanical seal	Various
408	1	Casing plug	304 Stainless steel
412	1	Impeller gasket	Teflon
413	1	Sleeve gasket	Teflon
414	1	Sleeve gasket	Teflon
470	*	Casing bolt nut	304 Stainless Steel

\* Dependent on pump model

**FLOFAB**

**SERIES PS Cross Section  
MODEL - PSF Frame mounted**

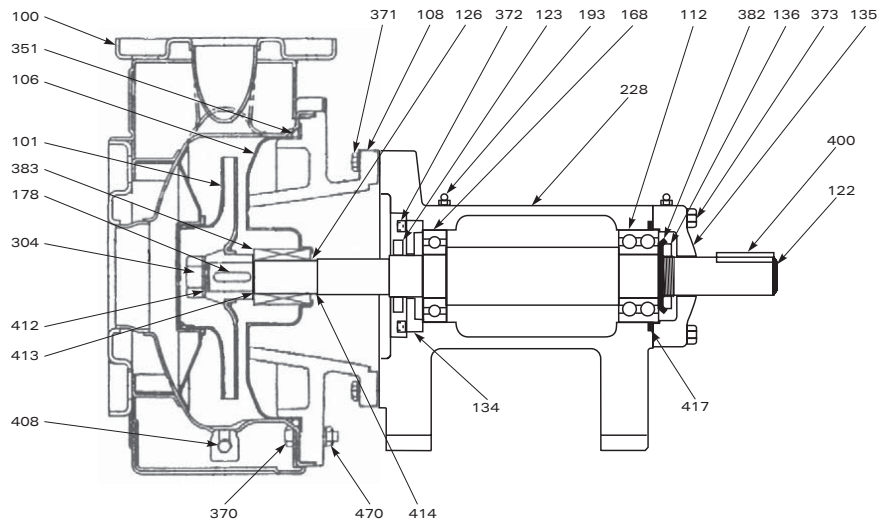

ITEM	QTY REQ'D	DESCRIPTION	MATERIAL
100	1	Casing	304 Stainless steel
101	1	Impeller	304 Stainless steel
106	1	Casing cover	304 Stainless steel
108	1	Adapter	Cast Iron
112	1	Thrust bearing	Steel
122	1	Shaft	Steel
123	1	Slinger	Rubber
126	1	Shaft sleeve	304 Stainless steel
134	1	Inboard brg cap	Steel
135	1	Outboard brg cap	Cast Iron
136	1	Brg lock nut	Steel
168	1	Radial bearing	Steel
178	1	Impeller key	304 Stainless steel
193	2	Grease fitting	Steel
228	1	Bearing frame	Cast Iron
304	1	Impeller bolt	304 Stainless steel
351	1	Casing o-ring	Buna (standard)
370	*	Casing bolt	304 Stainless steel
371	4	Frame bolt	Steel
372	4	Inboard cap bolt	Steel
373	4	Outboard cap bolt	Steel
382	1	Brg lock washer	Steel
383	1	Mechanical seal	Various
400	1	Shaft key	Steel
408	1	Casing plug	304 Stainless steel
412	1	Impeller gasket	Teflon
413	1	Sleeve gasket	Teflon
414	1	Sleeve gasket	Teflon
417	1	Retaining ring	Steel
470	*	Casing bolt nut	304 Stainless steel

\* Dependent on pump model



# SERIES PS Specifications MODEL - PSF

Model PSF Selection Chart (1725 RPM)

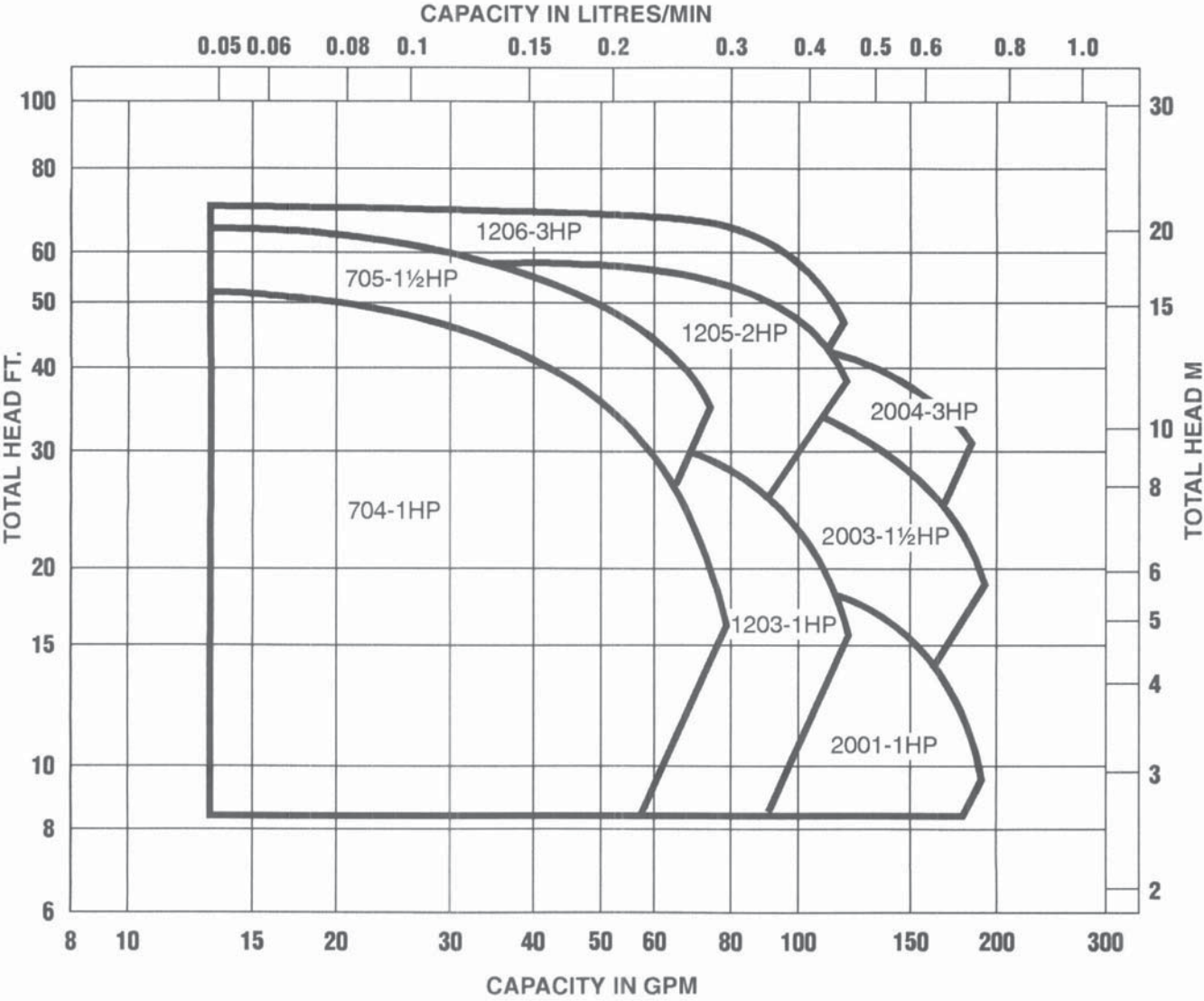



Series PS **MODEL PSF704**

CUSTOMER \_\_\_\_\_ REFERENCE \_\_\_\_\_

FLUID \_\_\_\_\_ S.G. \_\_\_\_\_ TEMP \_\_\_\_\_ CAPACITY \_\_\_\_\_ TDH \_\_\_\_\_

CERTIFIED: \_\_\_\_\_ DATE: \_\_\_\_\_

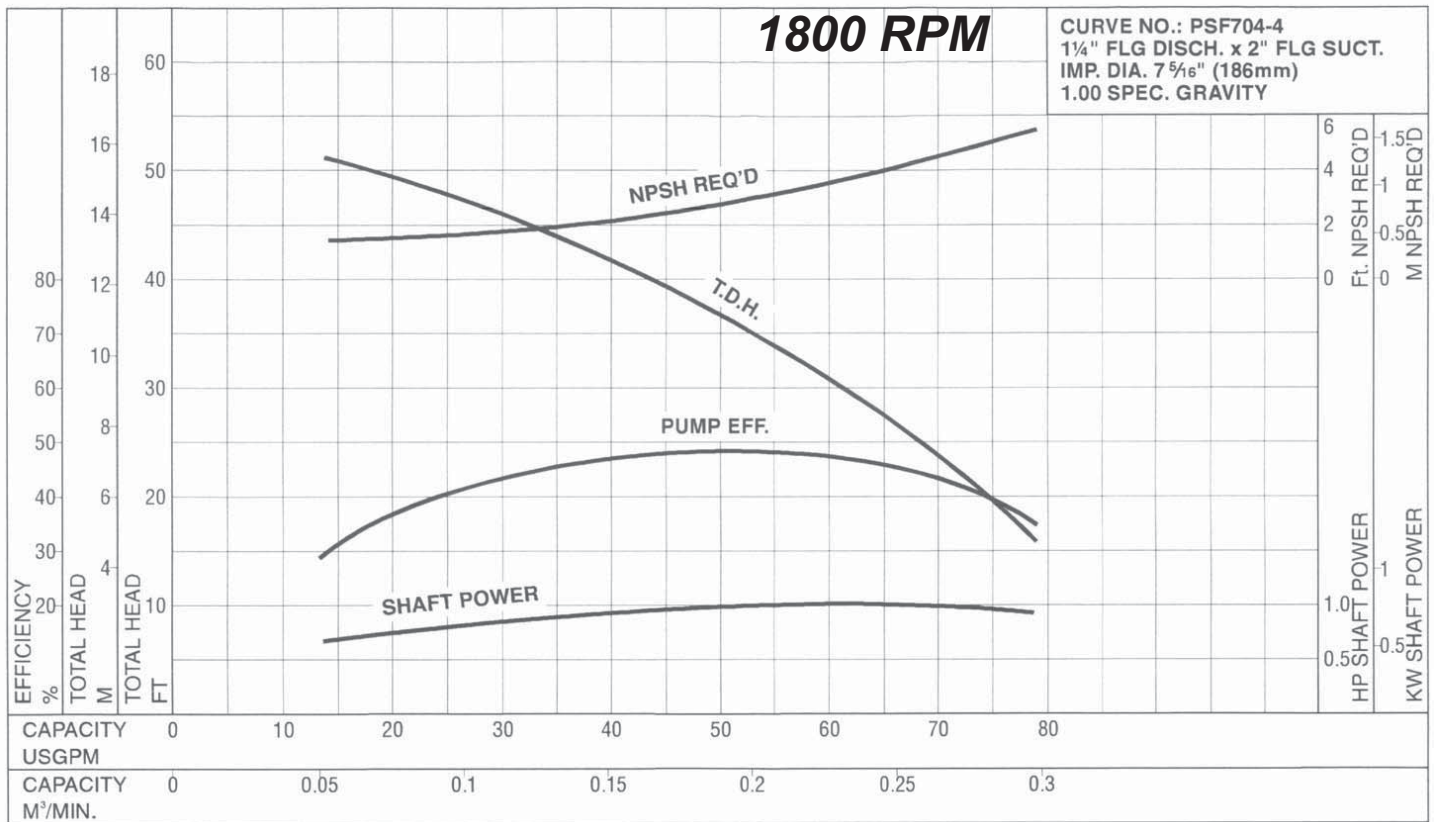



Series PS **MODEL PSF705**

CUSTOMER \_\_\_\_\_ REFERENCE \_\_\_\_\_

FLUID \_\_\_\_\_ S.G. \_\_\_\_\_ TEMP \_\_\_\_\_ CAPACITY \_\_\_\_\_ TDH \_\_\_\_\_

CERTIFIED: \_\_\_\_\_ DATE: \_\_\_\_\_

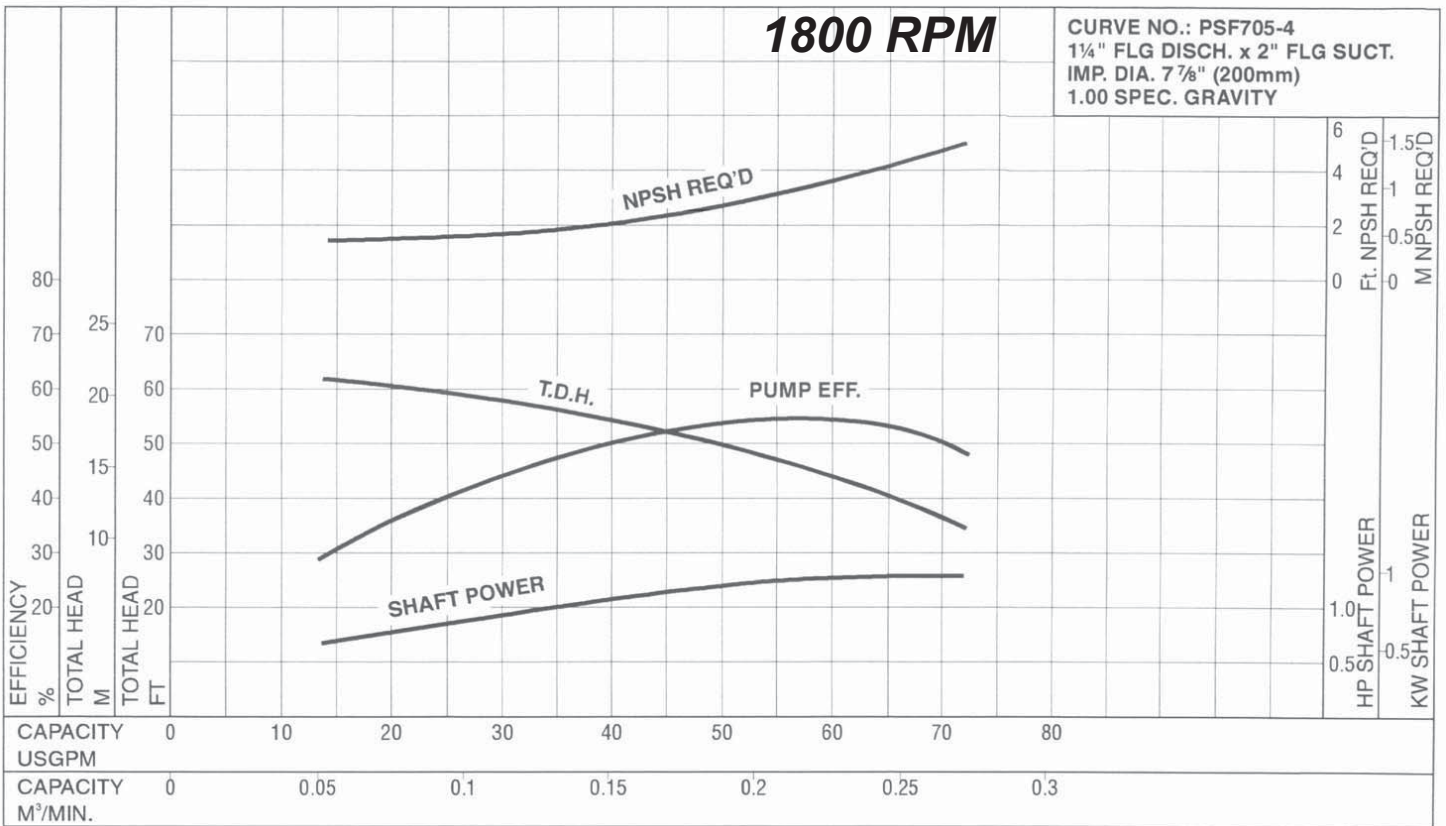



Series PS **MODEL PSF1203**

CUSTOMER \_\_\_\_\_ REFERENCE \_\_\_\_\_

FLUID \_\_\_\_\_ S.G. \_\_\_\_\_ TEMP \_\_\_\_\_ CAPACITY \_\_\_\_\_ TDH \_\_\_\_\_

CERTIFIED: \_\_\_\_\_ DATE: \_\_\_\_\_

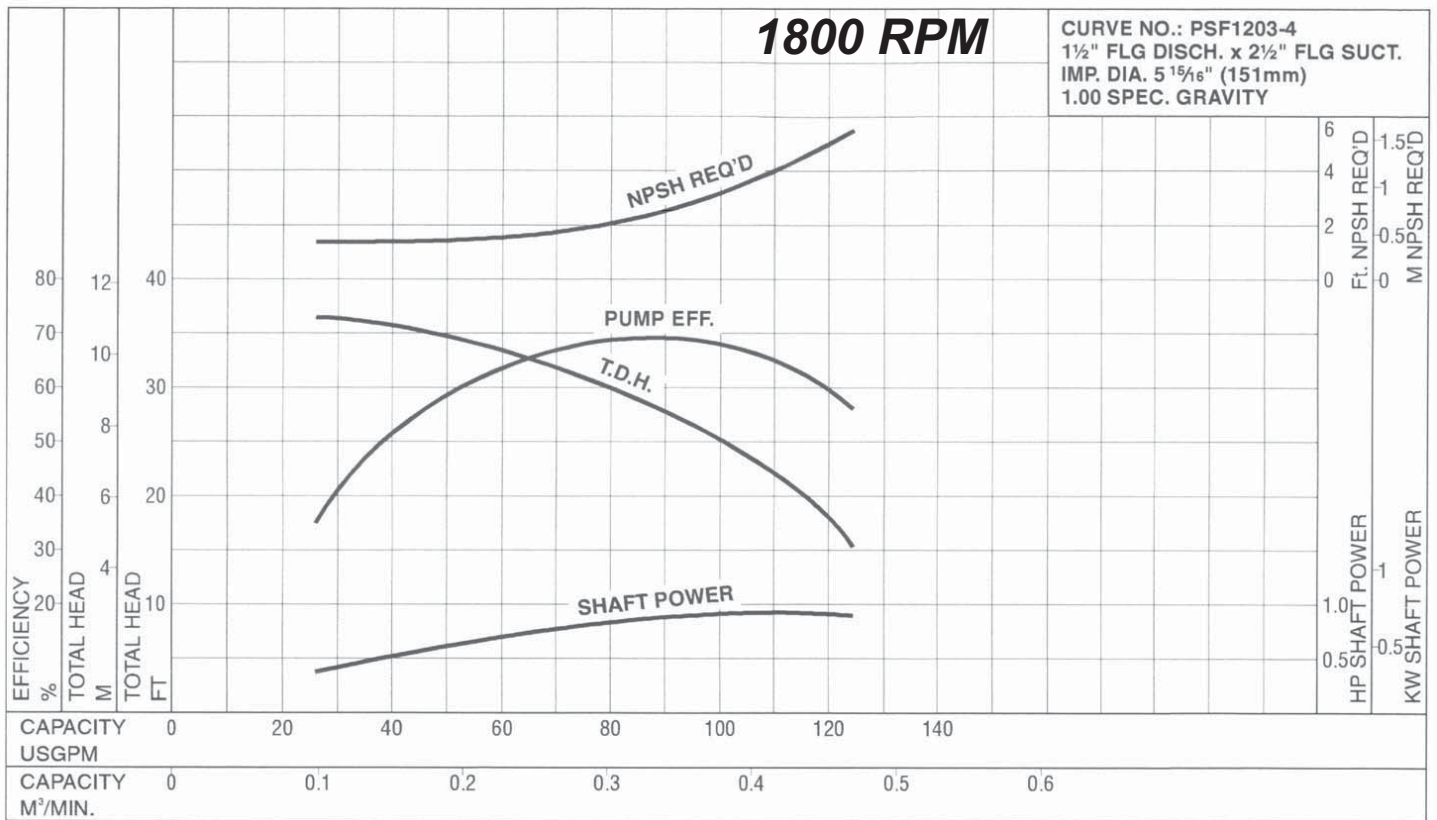





Series PS **MODEL PSF1205**

CUSTOMER \_\_\_\_\_ REFERENCE \_\_\_\_\_

FLUID \_\_\_\_\_ S.G. \_\_\_\_\_ TEMP \_\_\_\_\_ CAPACITY \_\_\_\_\_ TDH \_\_\_\_\_

CERTIFIED: \_\_\_\_\_ DATE: \_\_\_\_\_

**1800 RPM**

CURVE NO.: PSF1205-4  
 1½" FLG DISCH. x 2½" FLG SUCT.  
 IMP. DIA. 7 ¾" (183mm)  
 1.00 SPEC. GRAVITY

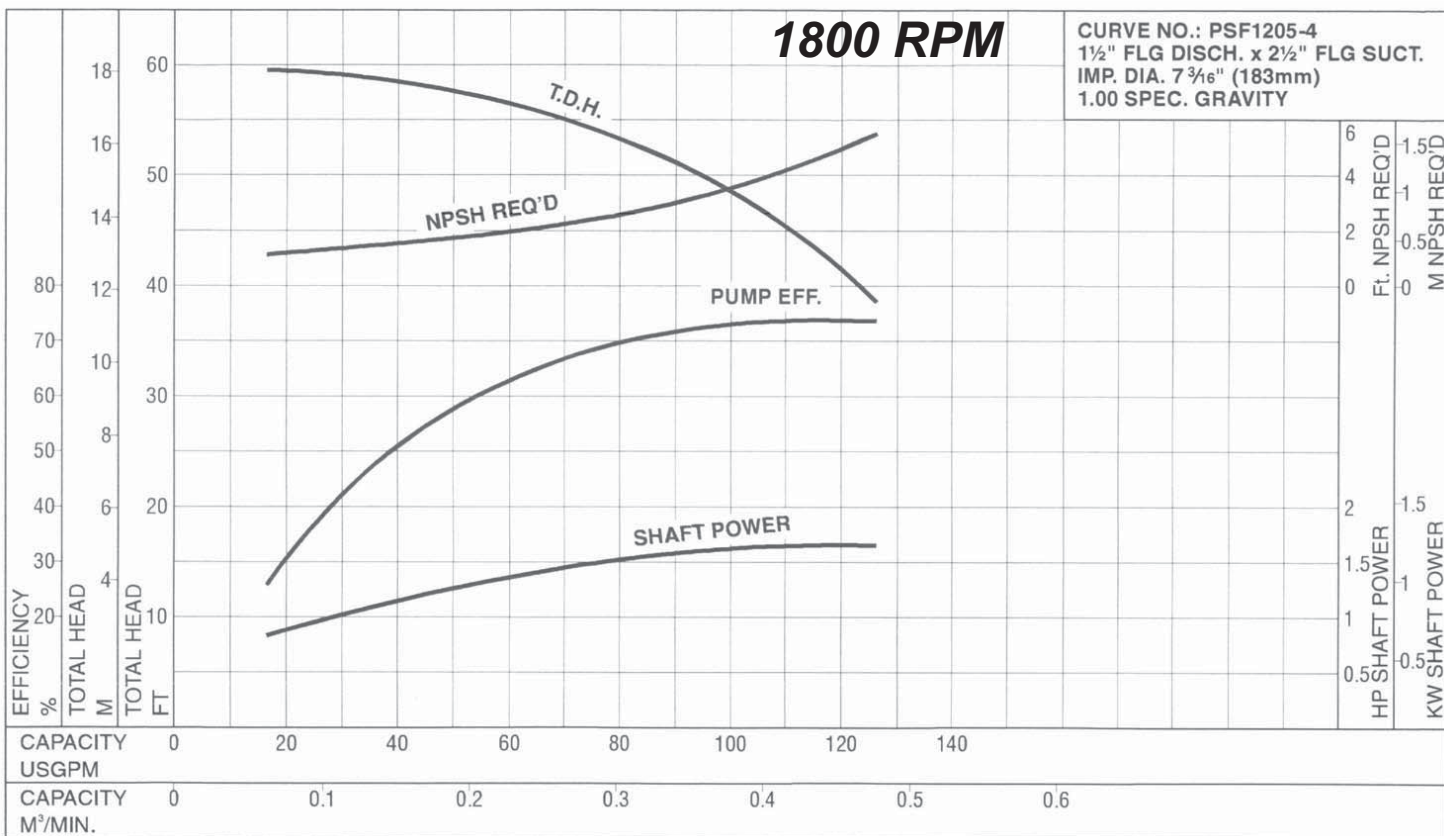



Series PS **MODEL PSF1206**

CUSTOMER \_\_\_\_\_ REFERENCE \_\_\_\_\_

FLUID \_\_\_\_\_ S.G. \_\_\_\_\_ TEMP \_\_\_\_\_ CAPACITY \_\_\_\_\_ TDH \_\_\_\_\_

CERTIFIED: \_\_\_\_\_ DATE: \_\_\_\_\_

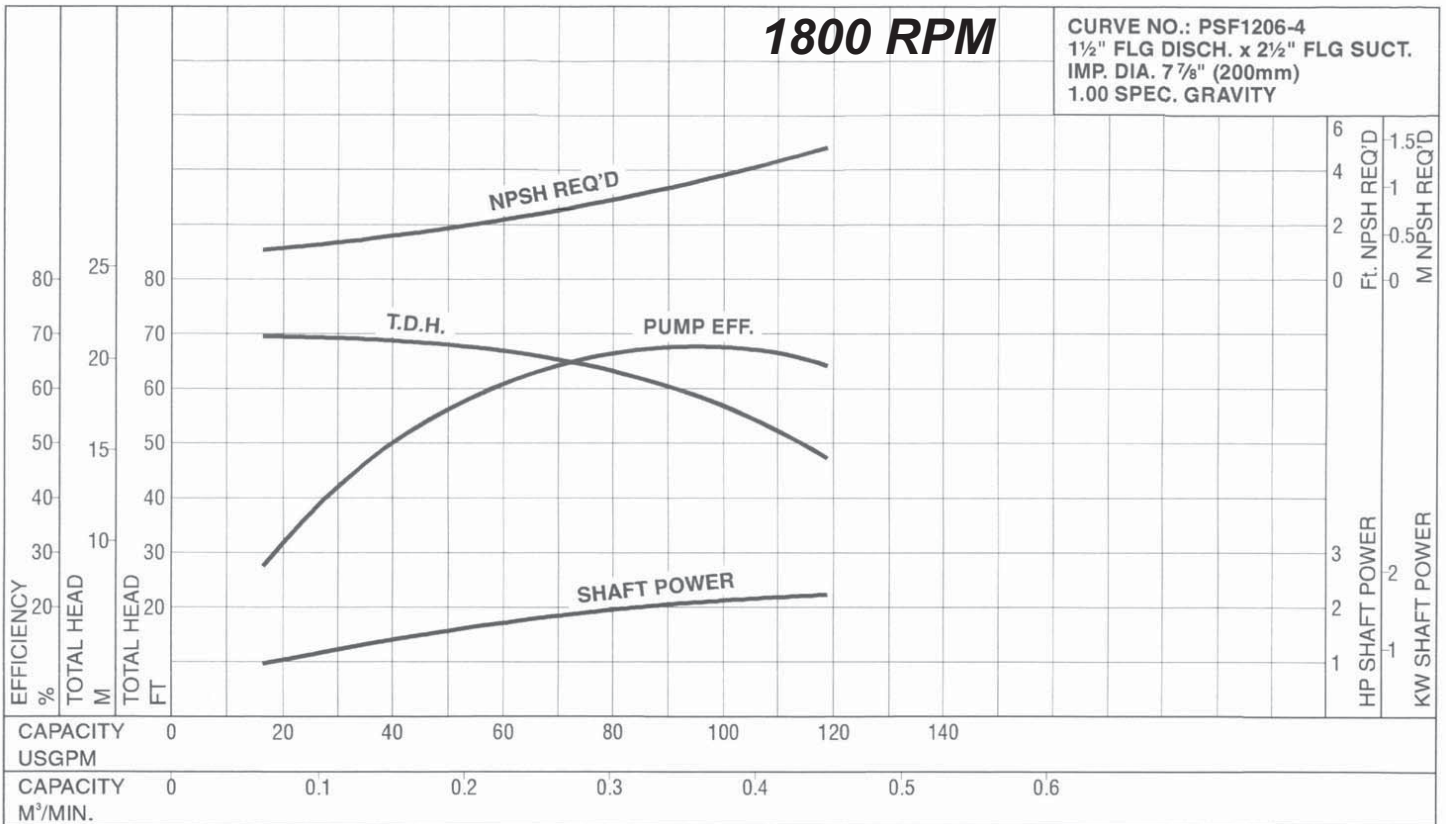



Series PS **MODEL PSF2001**

CUSTOMER \_\_\_\_\_ REFERENCE \_\_\_\_\_

FLUID \_\_\_\_\_ S.G. \_\_\_\_\_ TEMP \_\_\_\_\_ CAPACITY \_\_\_\_\_ TDH \_\_\_\_\_

CERTIFIED: \_\_\_\_\_ DATE: \_\_\_\_\_

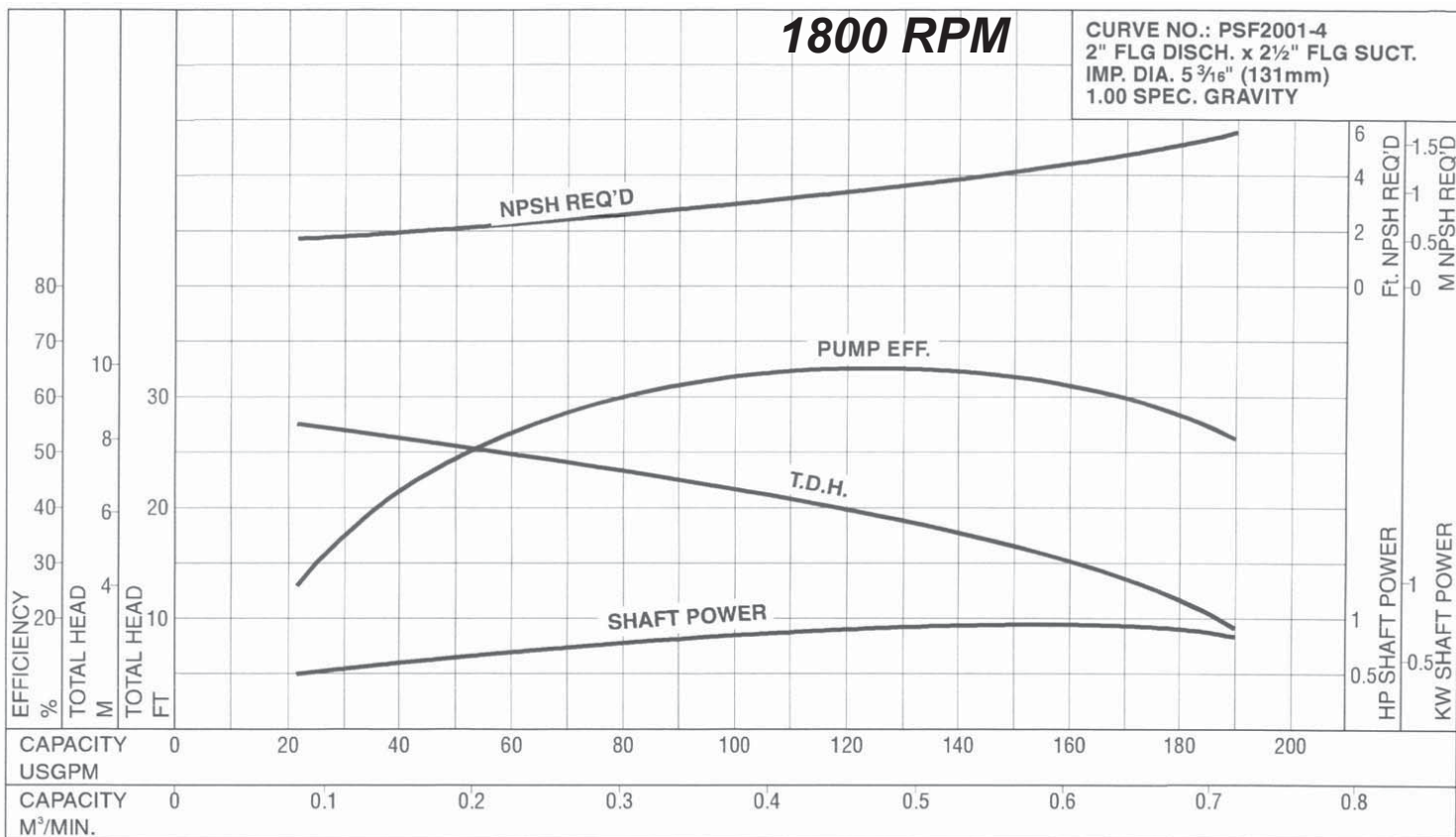



Series PS **MODEL PSF2003**

CUSTOMER \_\_\_\_\_ REFERENCE \_\_\_\_\_

FLUID \_\_\_\_\_ S.G. \_\_\_\_\_ TEMP \_\_\_\_\_ CAPACITY \_\_\_\_\_ TDH \_\_\_\_\_

CERTIFIED: \_\_\_\_\_ DATE: \_\_\_\_\_

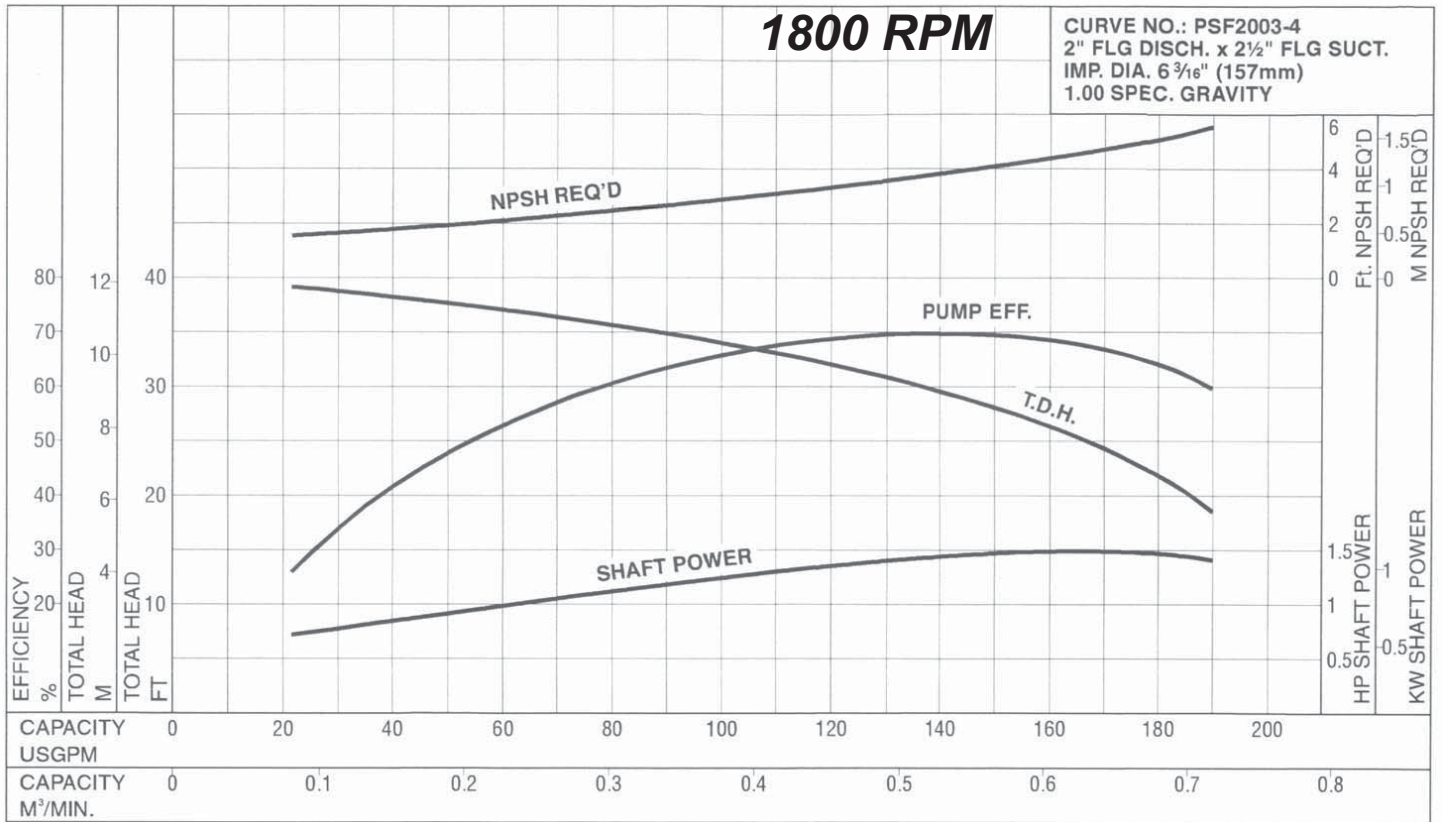



Series PS **MODEL PSF2004**

CUSTOMER \_\_\_\_\_ REFERENCE \_\_\_\_\_

FLUID \_\_\_\_\_ S.G. \_\_\_\_\_ TEMP \_\_\_\_\_ CAPACITY \_\_\_\_\_ TDH \_\_\_\_\_

CERTIFIED: \_\_\_\_\_ DATE: \_\_\_\_\_

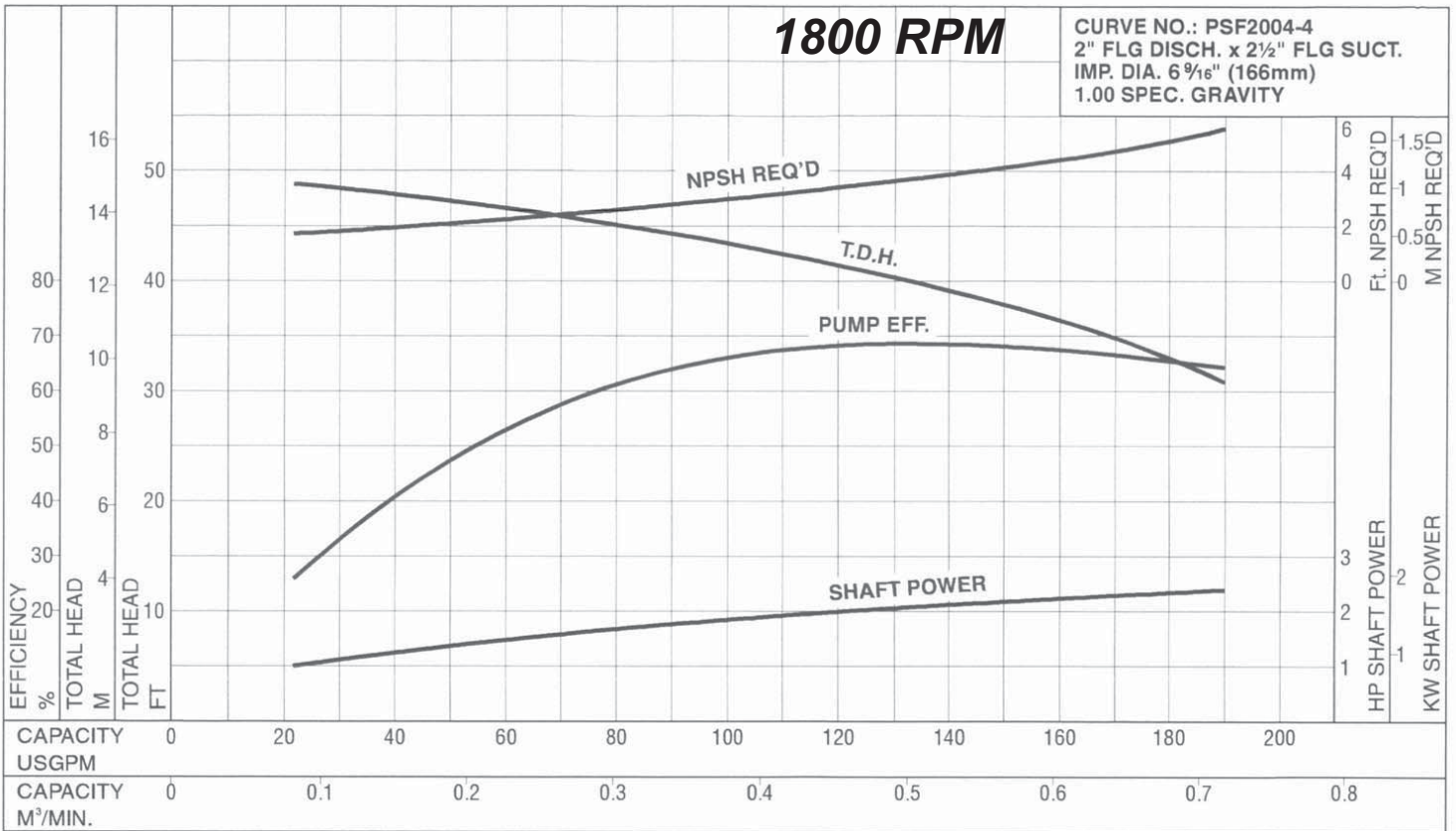



# SERIES PS Specifications MODEL - PSF

Model PSF Selection Chart (3450 RPM)

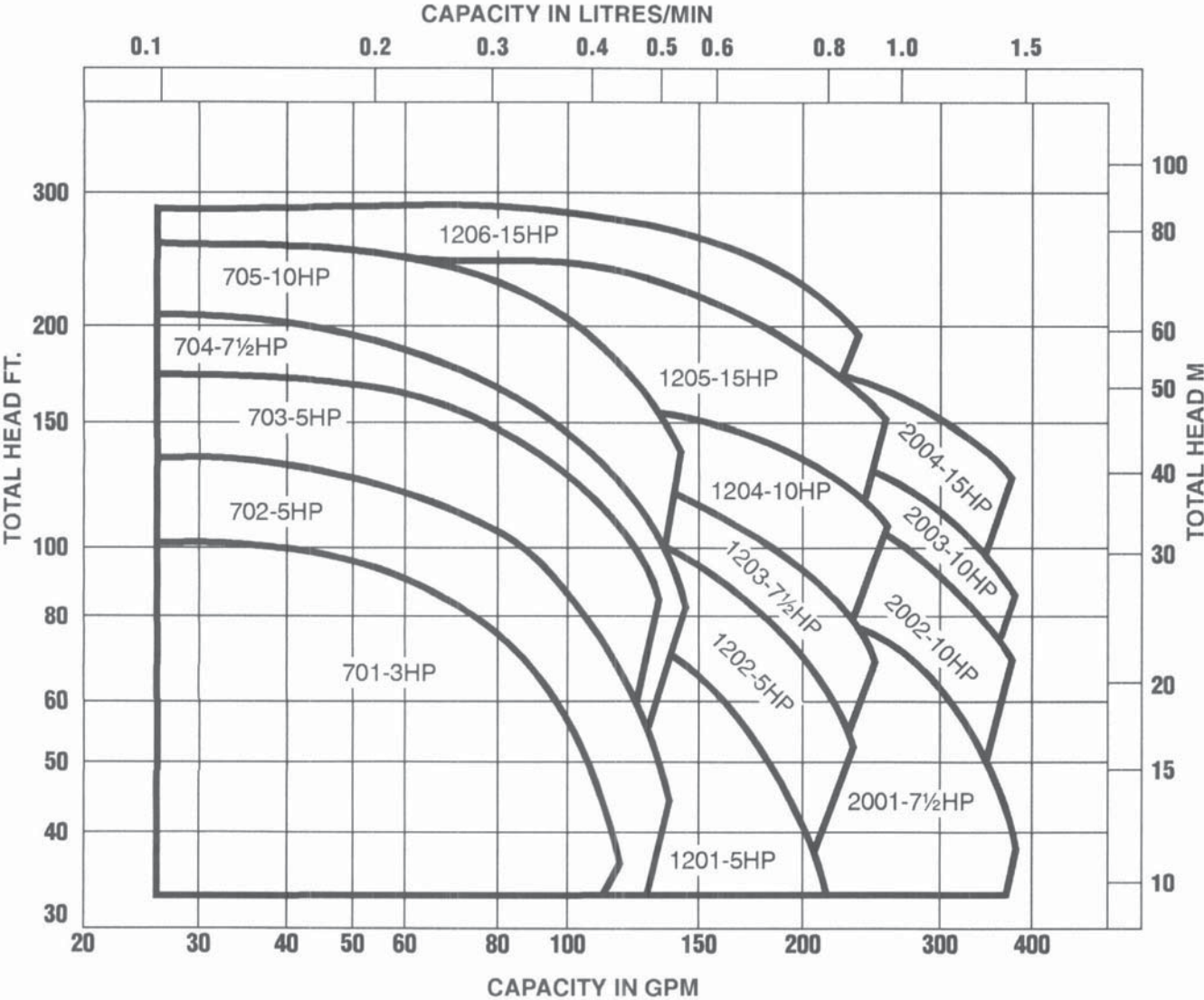





Series PS **MODEL PSF701**

CUSTOMER \_\_\_\_\_ REFERENCE \_\_\_\_\_

FLUID \_\_\_\_\_ S.G. \_\_\_\_\_ TEMP \_\_\_\_\_ CAPACITY \_\_\_\_\_ TDH \_\_\_\_\_

CERTIFIED: \_\_\_\_\_ DATE: \_\_\_\_\_

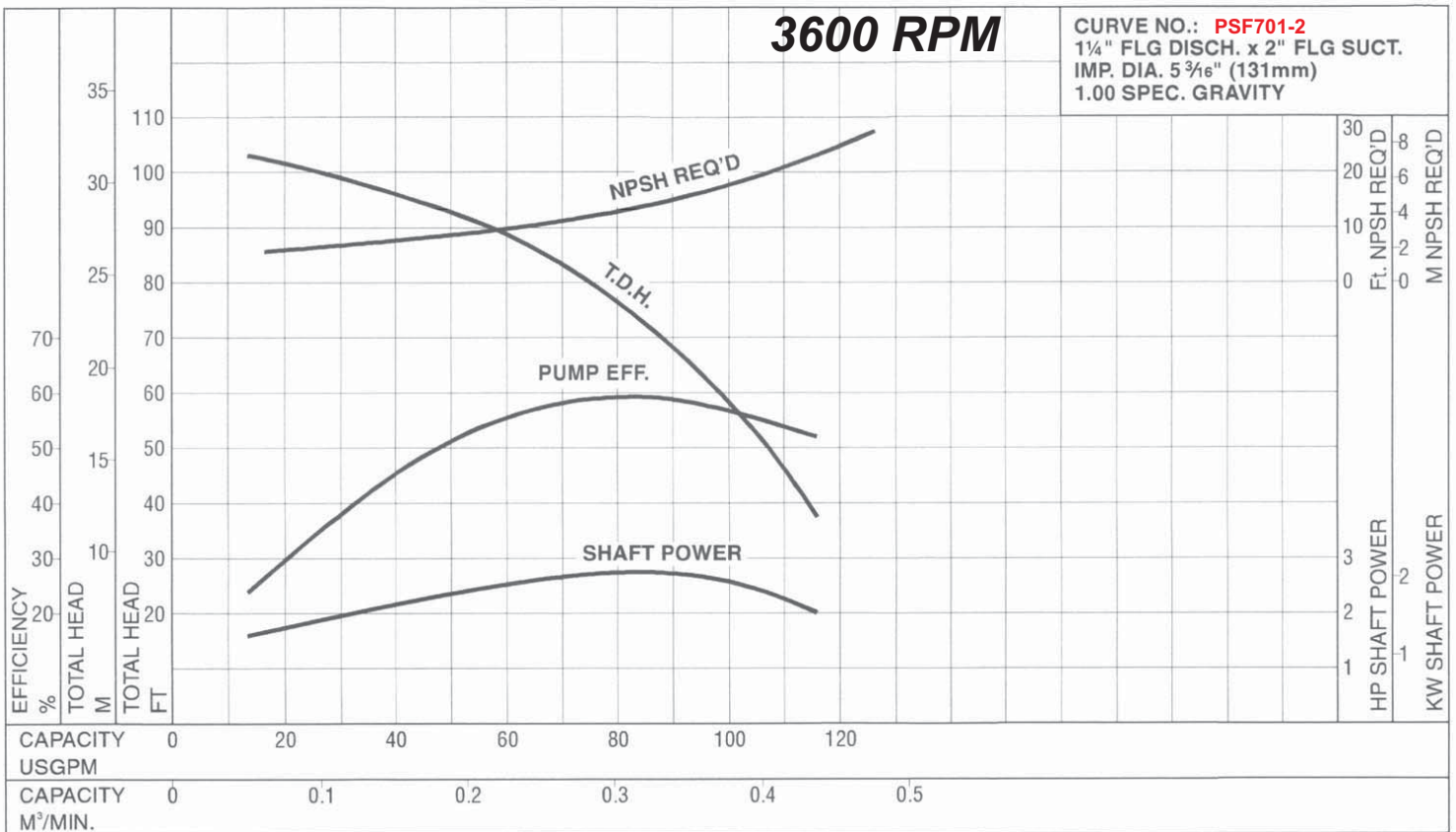





Series PS **MODEL PSF702**

CUSTOMER \_\_\_\_\_ REFERENCE \_\_\_\_\_

FLUID \_\_\_\_\_ S.G. \_\_\_\_\_ TEMP \_\_\_\_\_ CAPACITY \_\_\_\_\_ TDH \_\_\_\_\_

CERTIFIED: \_\_\_\_\_ DATE: \_\_\_\_\_

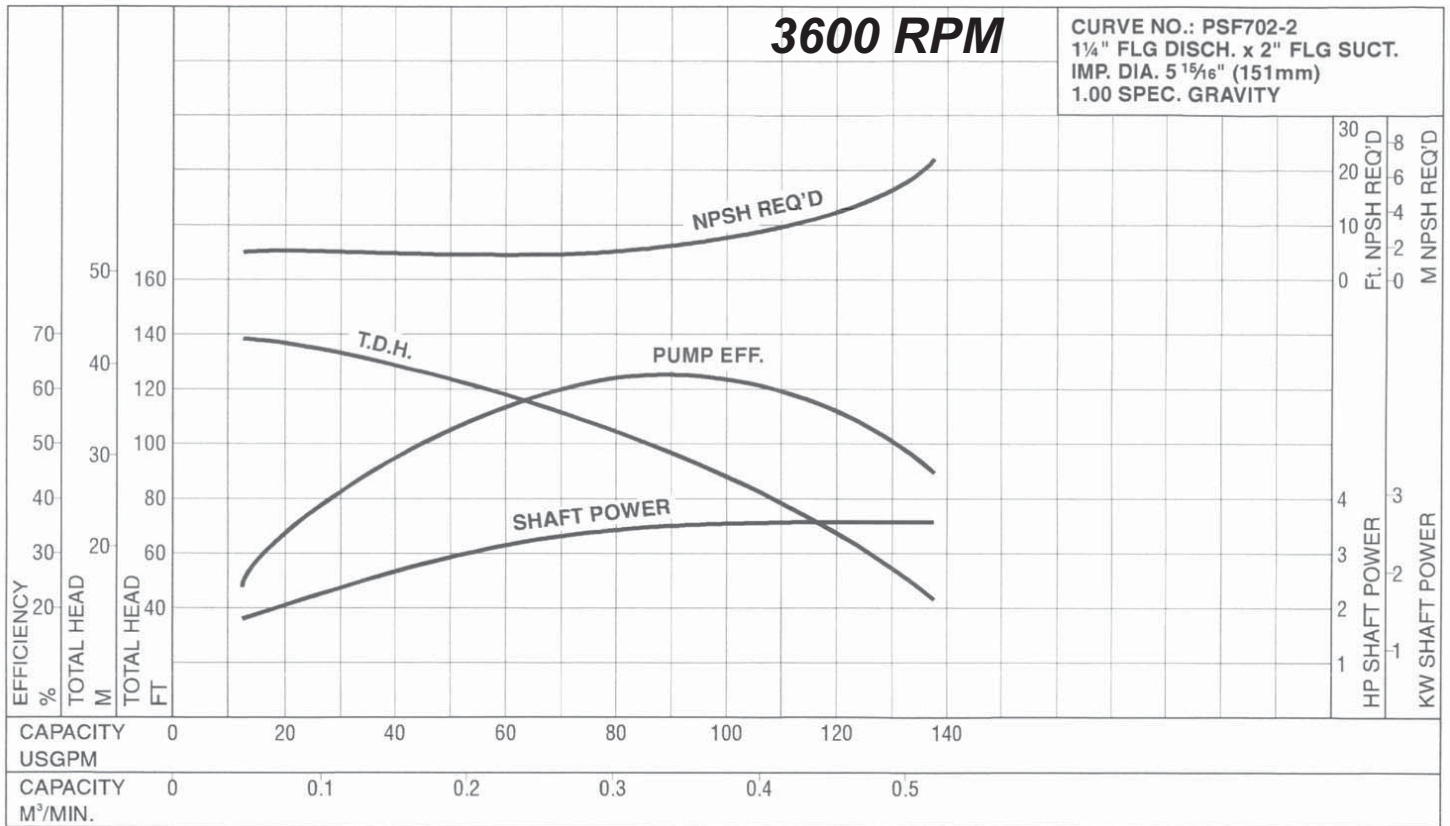



Series PS **MODEL PSF703**

CUSTOMER \_\_\_\_\_ REFERENCE \_\_\_\_\_

FLUID \_\_\_\_\_ S.G. \_\_\_\_\_ TEMP \_\_\_\_\_ CAPACITY \_\_\_\_\_ TDH \_\_\_\_\_

CERTIFIED: \_\_\_\_\_ DATE: \_\_\_\_\_

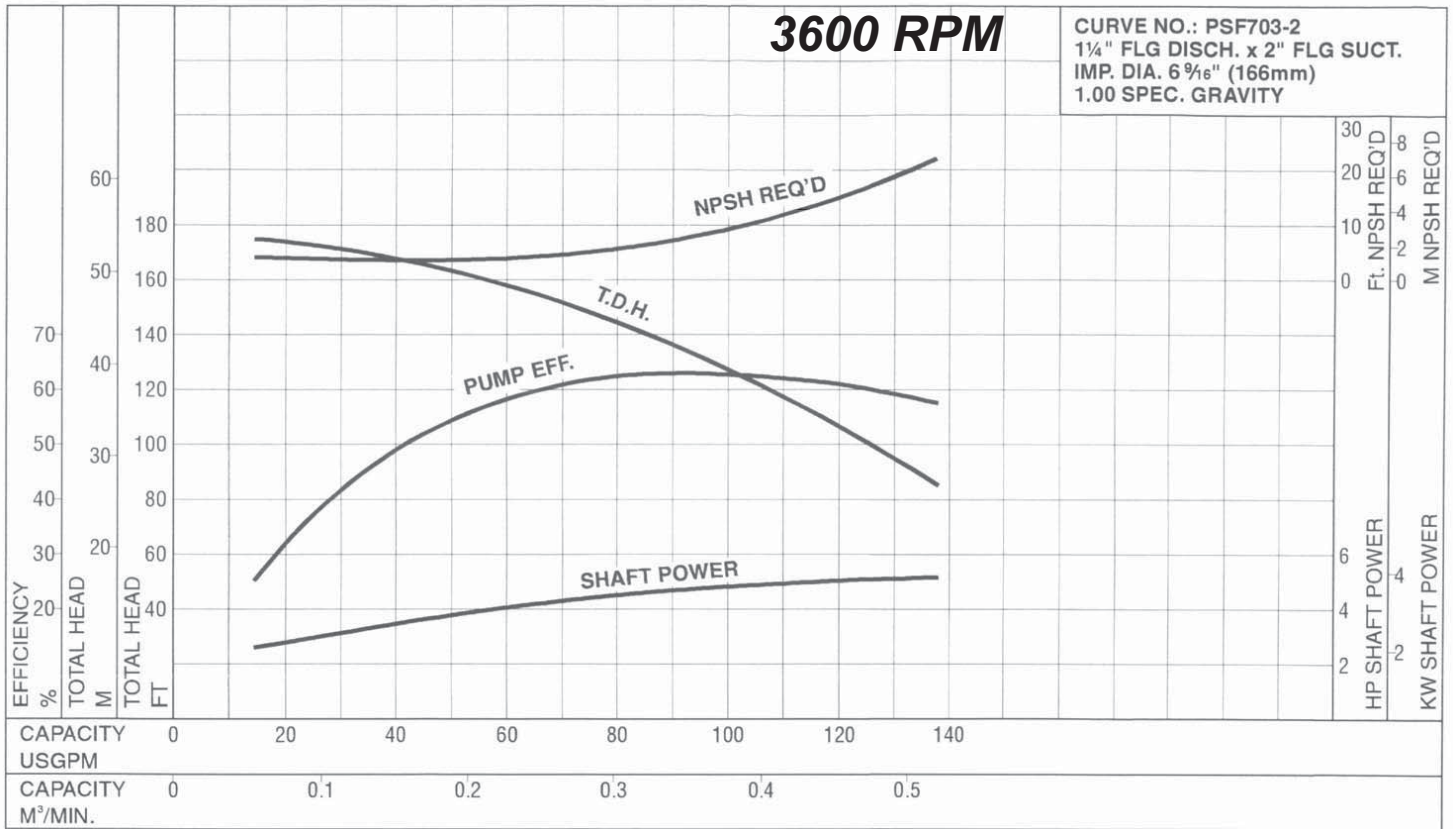



Series PS **MODEL PSF704**

CUSTOMER \_\_\_\_\_ REFERENCE \_\_\_\_\_

FLUID \_\_\_\_\_ S.G. \_\_\_\_\_ TEMP \_\_\_\_\_ CAPACITY \_\_\_\_\_ TDH \_\_\_\_\_

CERTIFIED: \_\_\_\_\_ DATE: \_\_\_\_\_

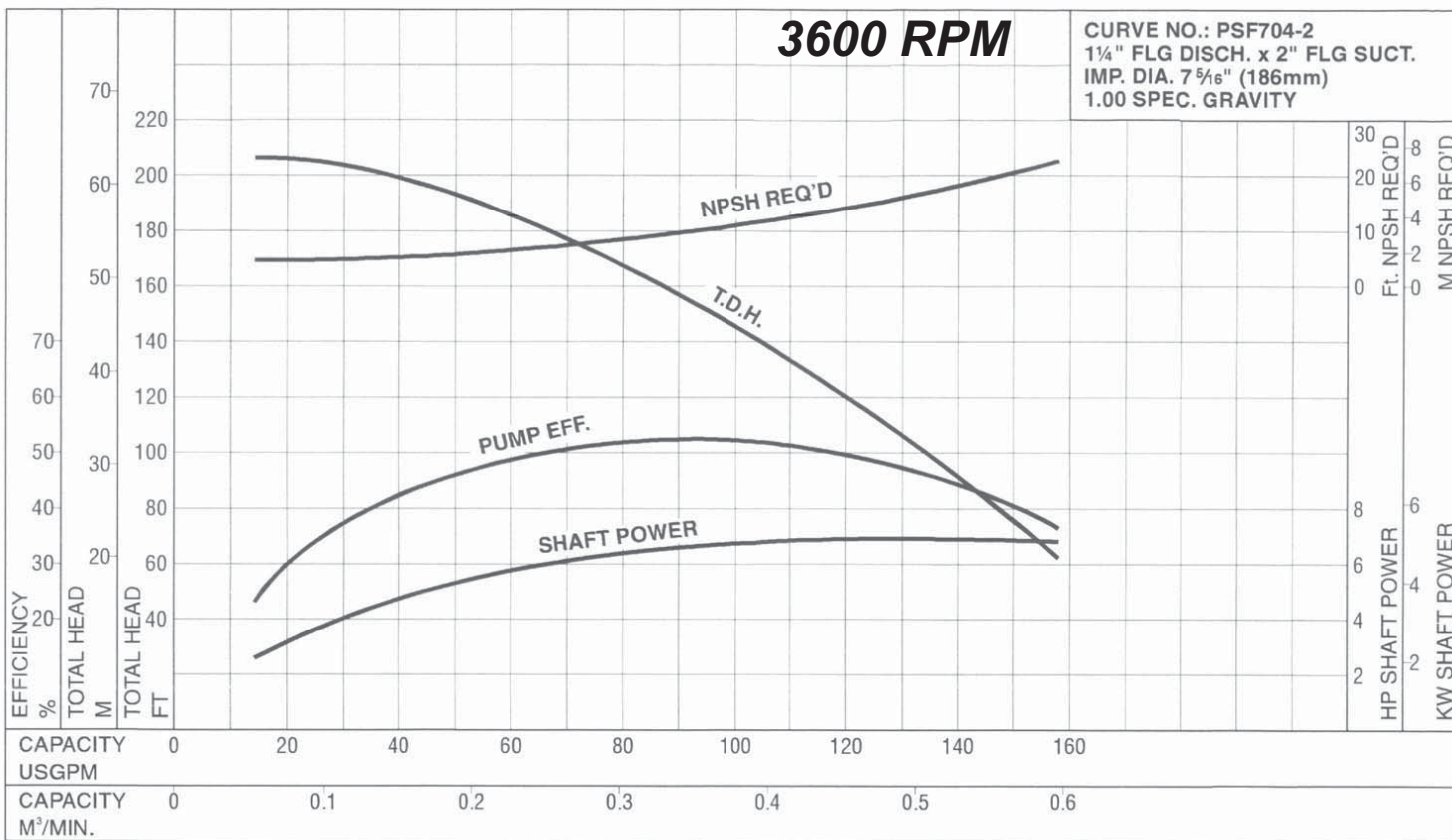

# FLOFAB

## Series PS **MODEL PSF705**

CUSTOMER \_\_\_\_\_ REFERENCE \_\_\_\_\_

FLUID \_\_\_\_\_ S.G. \_\_\_\_\_ TEMP \_\_\_\_\_ CAPACITY \_\_\_\_\_ TDH \_\_\_\_\_

CERTIFIED: \_\_\_\_\_ DATE: \_\_\_\_\_

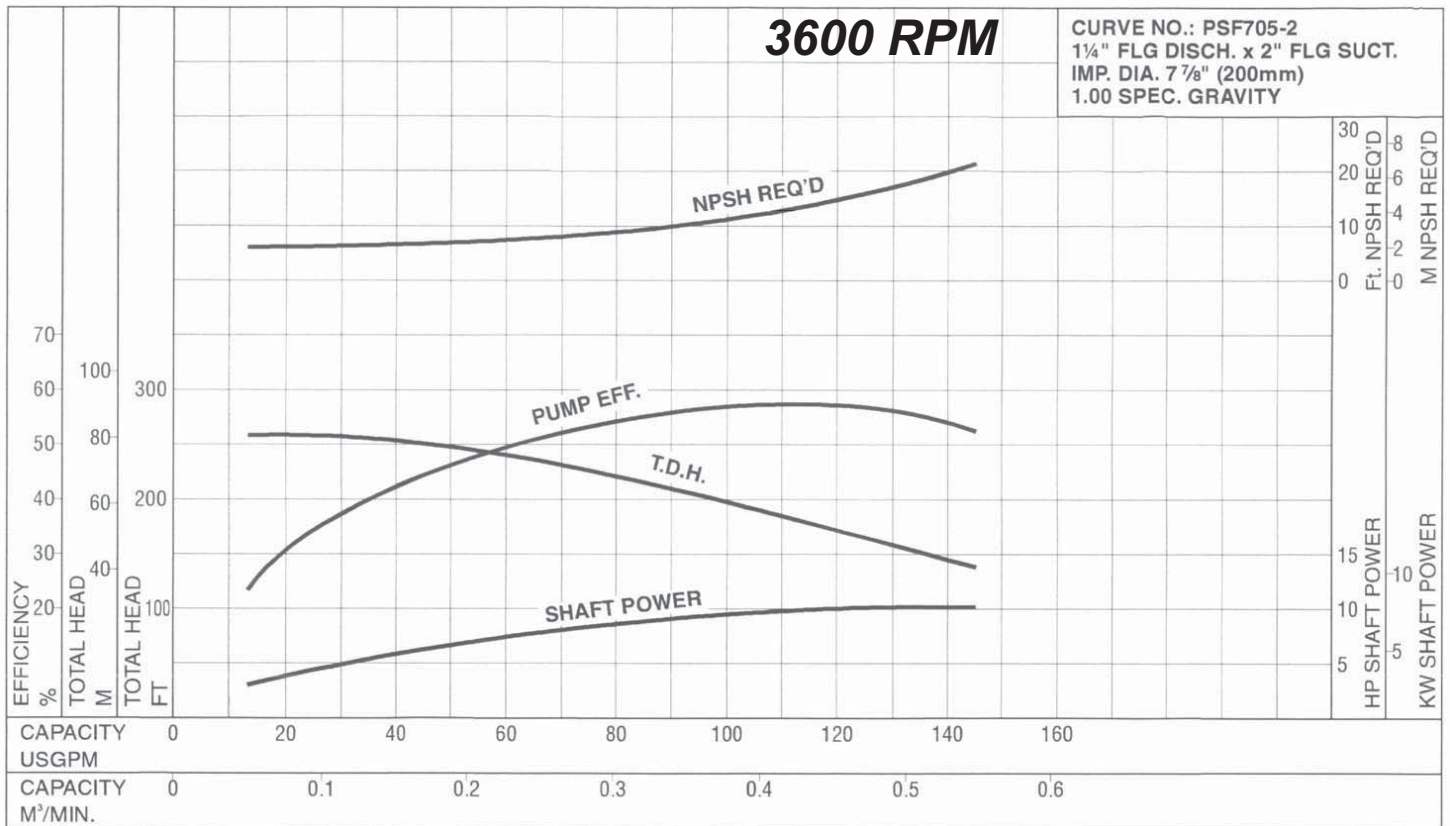



Series PS **MODEL PSF1201**

CUSTOMER \_\_\_\_\_ REFERENCE \_\_\_\_\_

FLUID \_\_\_\_\_ S.G. \_\_\_\_\_ TEMP \_\_\_\_\_ CAPACITY \_\_\_\_\_ TDH \_\_\_\_\_

CERTIFIED: \_\_\_\_\_ DATE: \_\_\_\_\_

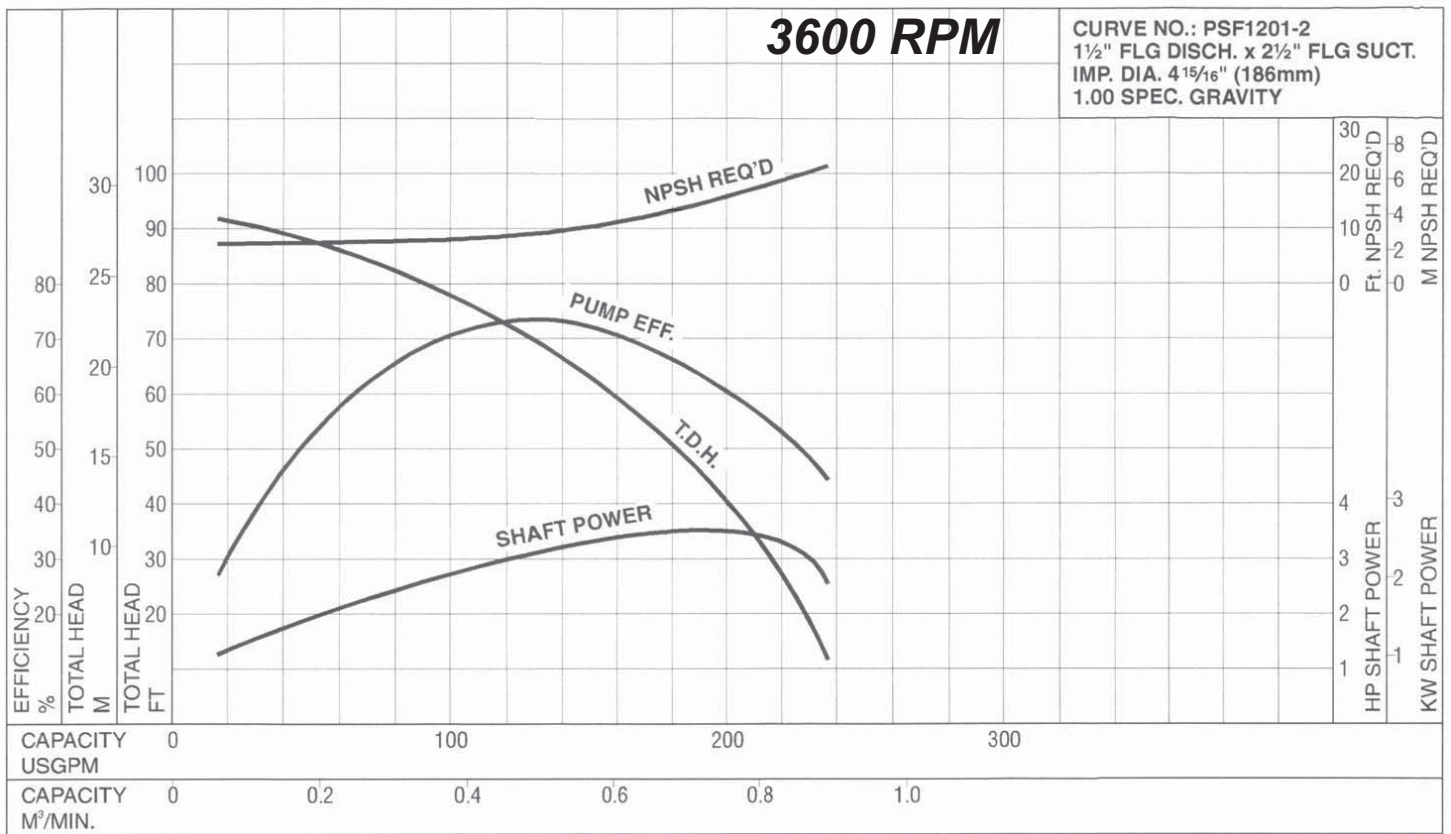



Series PS **MODEL PSF1202**

CUSTOMER \_\_\_\_\_ REFERENCE \_\_\_\_\_

FLUID \_\_\_\_\_ S.G. \_\_\_\_\_ TEMP \_\_\_\_\_ CAPACITY \_\_\_\_\_ TDH \_\_\_\_\_

CERTIFIED: \_\_\_\_\_ DATE: \_\_\_\_\_

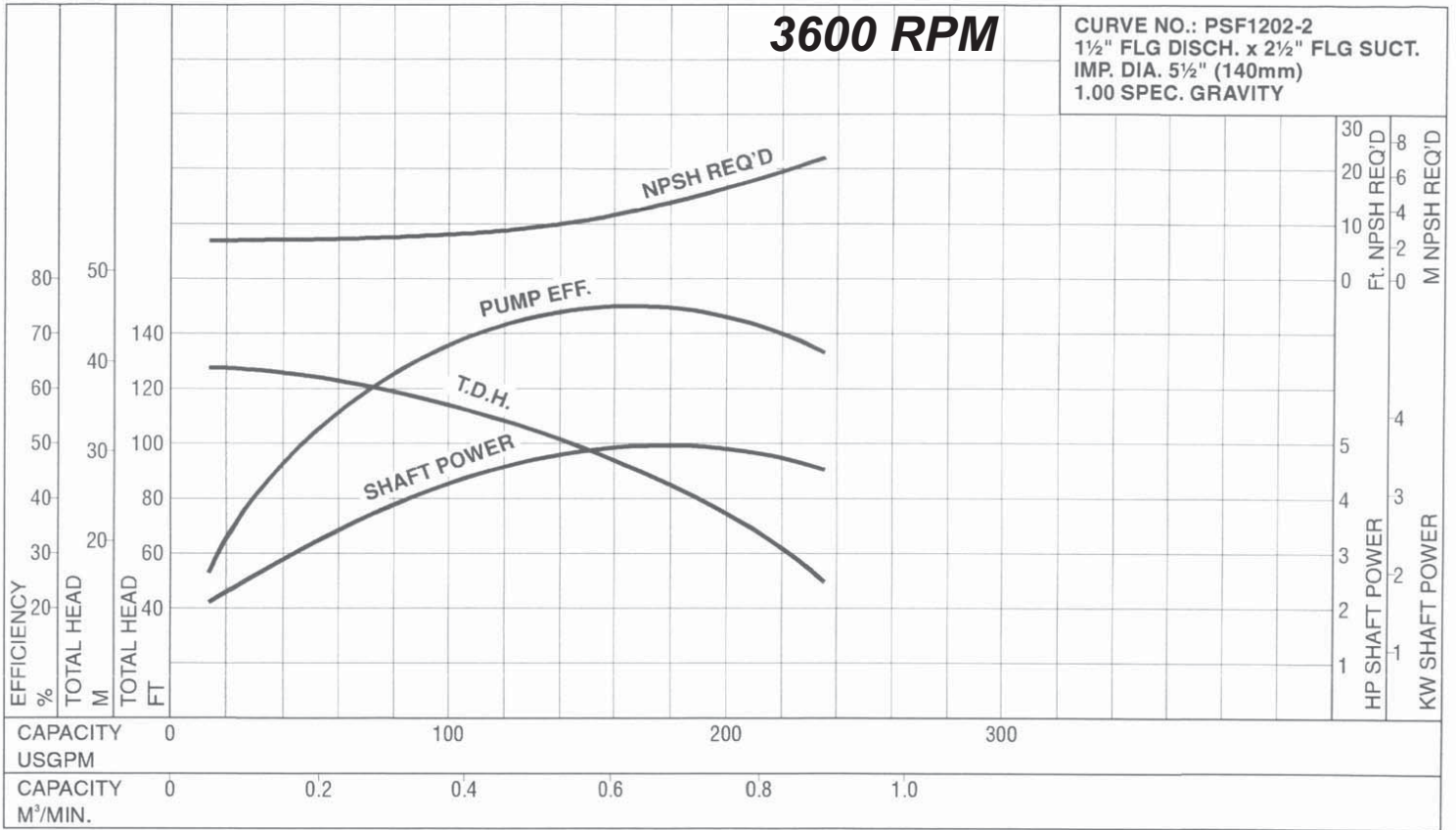



Series PS **MODEL PSF1203**

CUSTOMER \_\_\_\_\_ REFERENCE \_\_\_\_\_

FLUID \_\_\_\_\_ S.G. \_\_\_\_\_ TEMP \_\_\_\_\_ CAPACITY \_\_\_\_\_ TDH \_\_\_\_\_

CERTIFIED: \_\_\_\_\_ DATE: \_\_\_\_\_

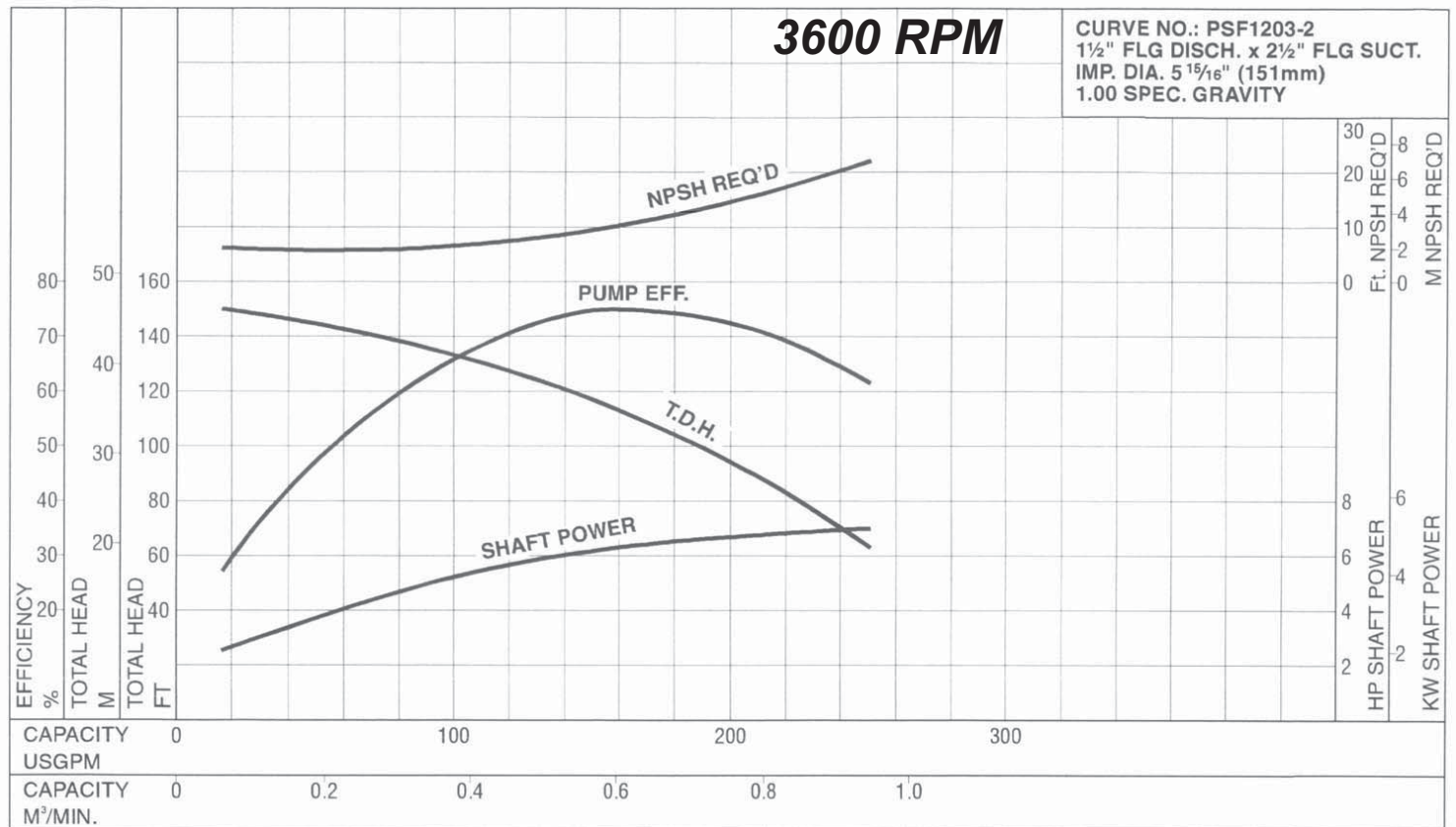





Series PS **MODEL PSF1204**

CUSTOMER \_\_\_\_\_ REFERENCE \_\_\_\_\_

FLUID \_\_\_\_\_ S.G. \_\_\_\_\_ TEMP \_\_\_\_\_ CAPACITY \_\_\_\_\_ TDH \_\_\_\_\_

CERTIFIED: \_\_\_\_\_ DATE: \_\_\_\_\_

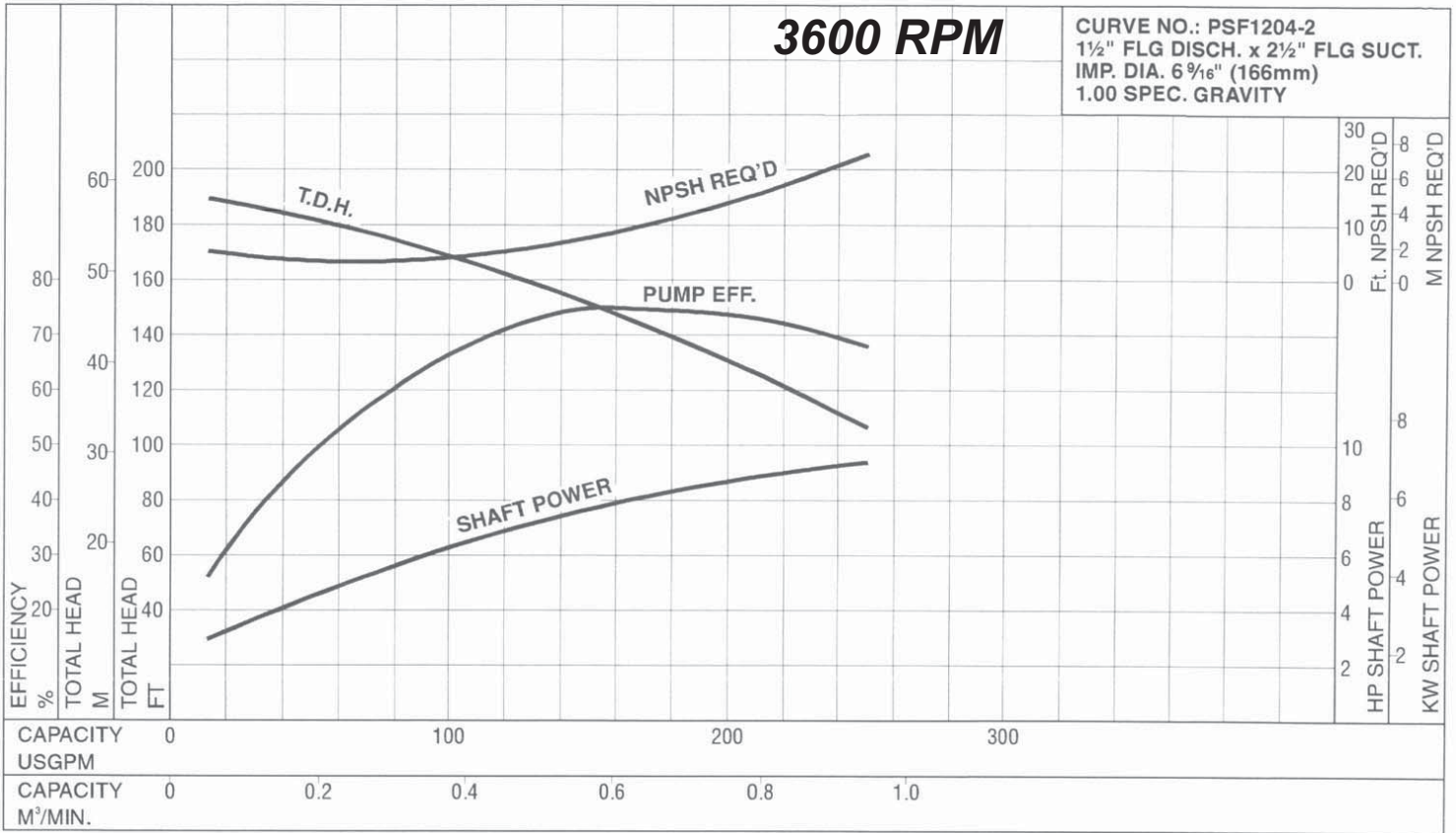



Series PS **MODEL PSF1205**

CUSTOMER \_\_\_\_\_ REFERENCE \_\_\_\_\_  
 FLUID \_\_\_\_\_ S.G. \_\_\_\_\_ TEMP \_\_\_\_\_ CAPACITY \_\_\_\_\_ TDH \_\_\_\_\_  
 CERTIFIED: \_\_\_\_\_ DATE: \_\_\_\_\_

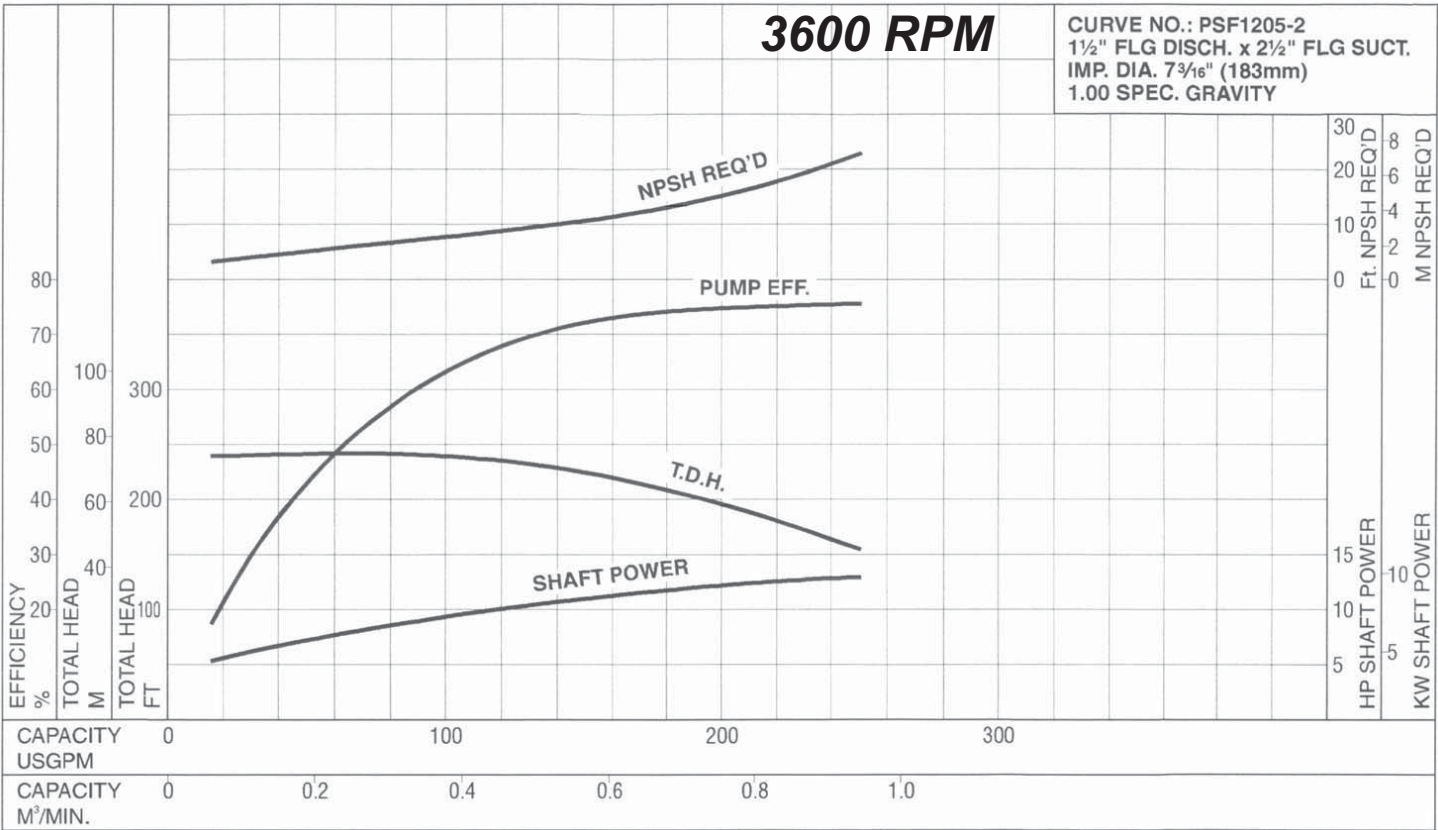



Series PS **MODEL PSF1206**

CUSTOMER \_\_\_\_\_ REFERENCE \_\_\_\_\_

FLUID \_\_\_\_\_ S.G. \_\_\_\_\_ TEMP \_\_\_\_\_ CAPACITY \_\_\_\_\_ TDH \_\_\_\_\_

CERTIFIED: \_\_\_\_\_ DATE: \_\_\_\_\_

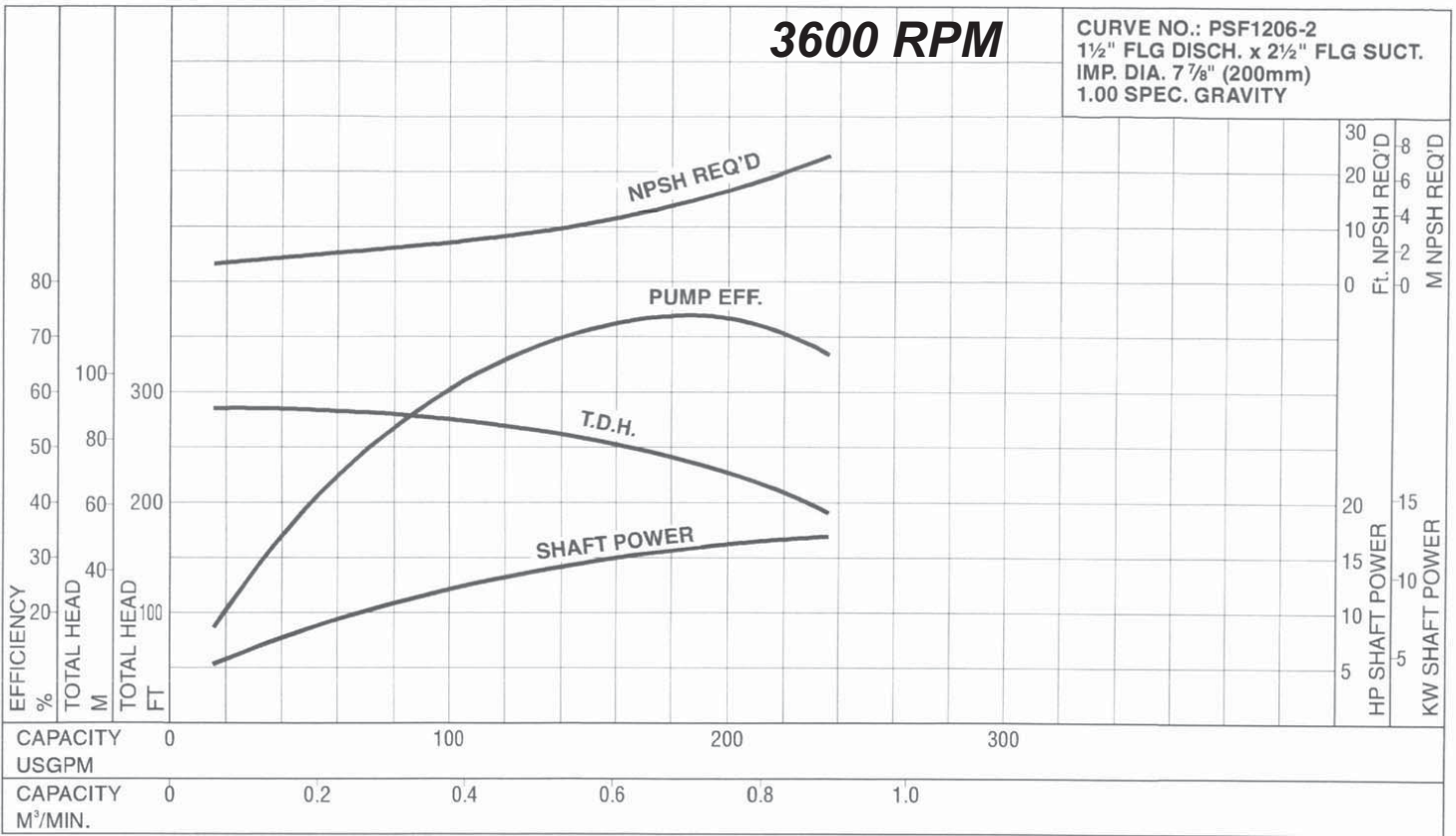



Series PS **MODEL PSF2001**

CUSTOMER \_\_\_\_\_ REFERENCE \_\_\_\_\_

FLUID \_\_\_\_\_ S.G. \_\_\_\_\_ TEMP \_\_\_\_\_ CAPACITY \_\_\_\_\_ TDH \_\_\_\_\_

CERTIFIED: \_\_\_\_\_ DATE: \_\_\_\_\_

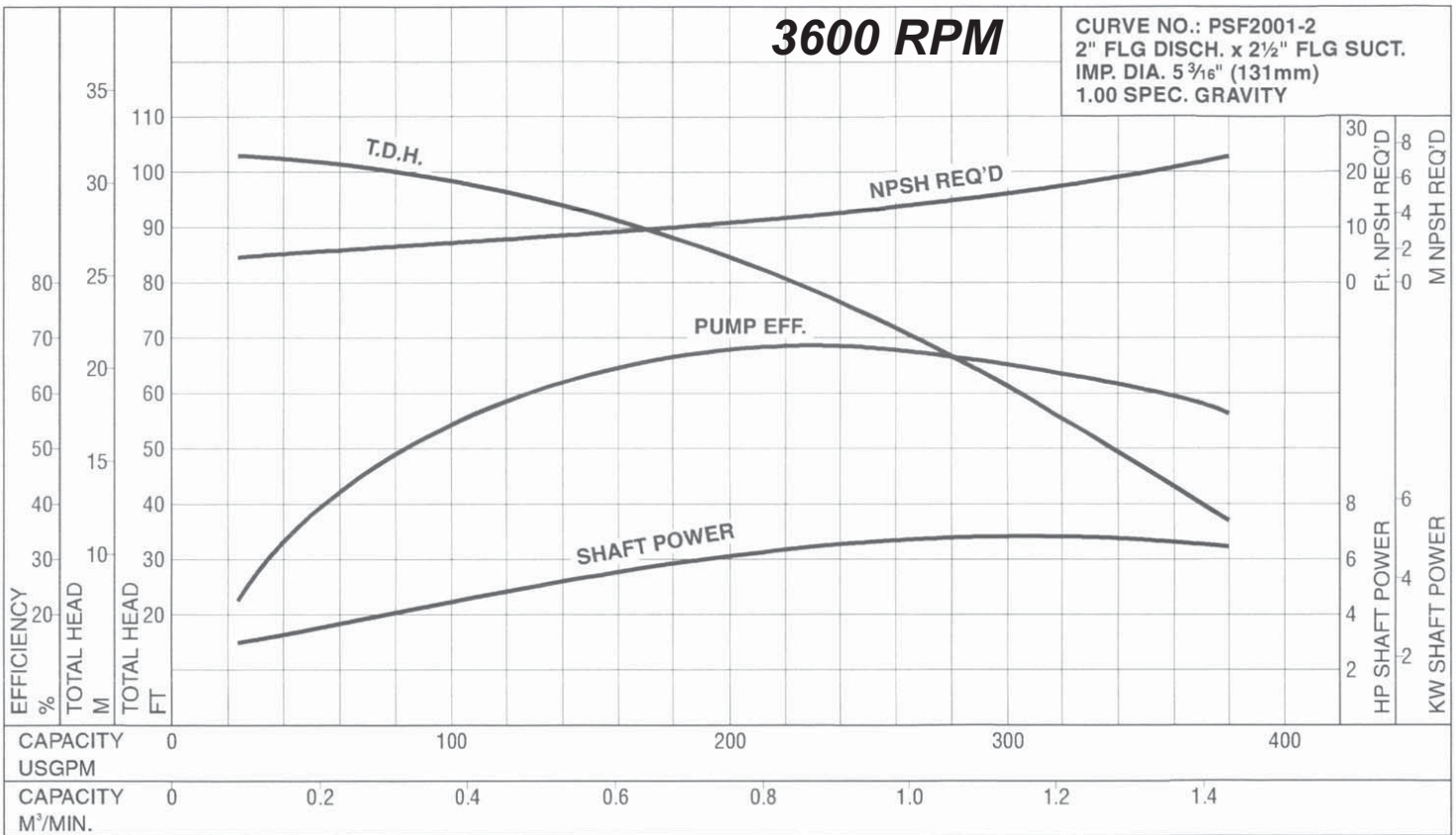



Series PS **MODEL PSF2002**

CUSTOMER \_\_\_\_\_ REFERENCE \_\_\_\_\_  
 FLUID \_\_\_\_\_ S.G. \_\_\_\_\_ TEMP \_\_\_\_\_ CAPACITY \_\_\_\_\_ TDH \_\_\_\_\_  
 CERTIFIED: \_\_\_\_\_ DATE: \_\_\_\_\_

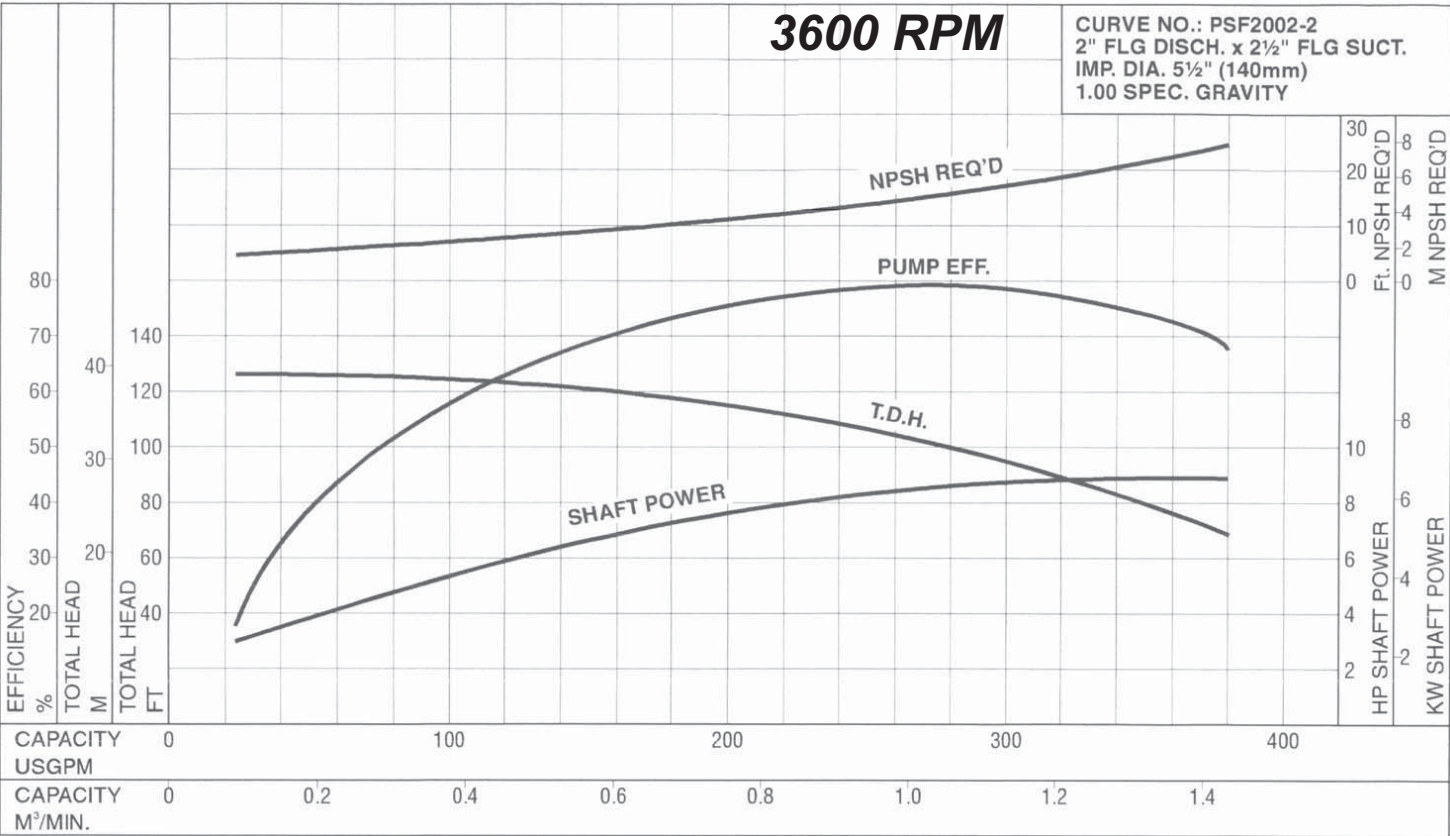



Series PS **MODEL PSF2003**

CUSTOMER \_\_\_\_\_ REFERENCE \_\_\_\_\_

FLUID \_\_\_\_\_ S.G. \_\_\_\_\_ TEMP \_\_\_\_\_ CAPACITY \_\_\_\_\_ TDH \_\_\_\_\_

CERTIFIED: \_\_\_\_\_ DATE: \_\_\_\_\_

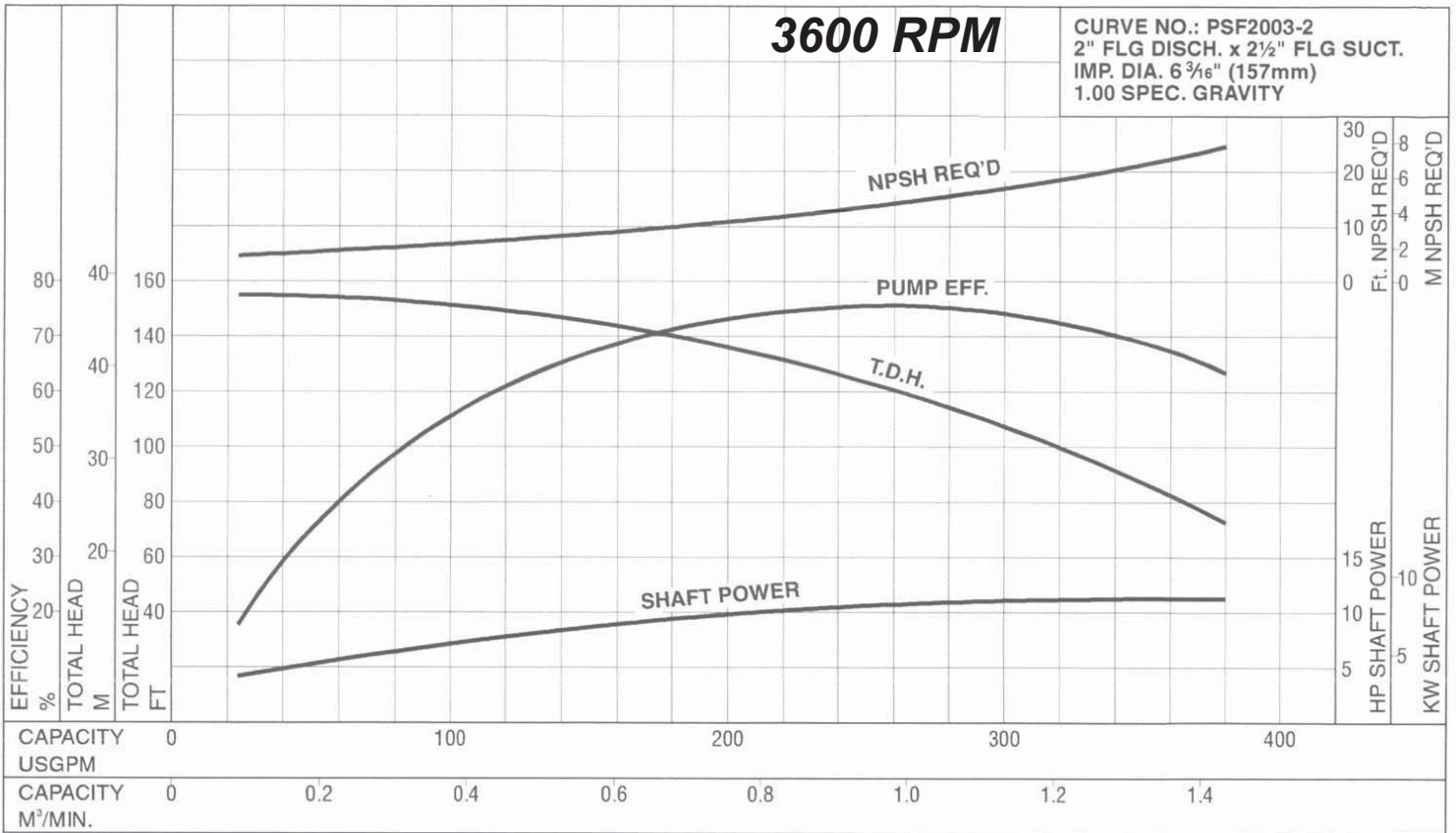





Series PS **MODEL PSF2004**

CUSTOMER \_\_\_\_\_ REFERENCE \_\_\_\_\_

FLUID \_\_\_\_\_ S.G. \_\_\_\_\_ TEMP \_\_\_\_\_ CAPACITY \_\_\_\_\_ TDH \_\_\_\_\_

CERTIFIED: \_\_\_\_\_ DATE: \_\_\_\_\_

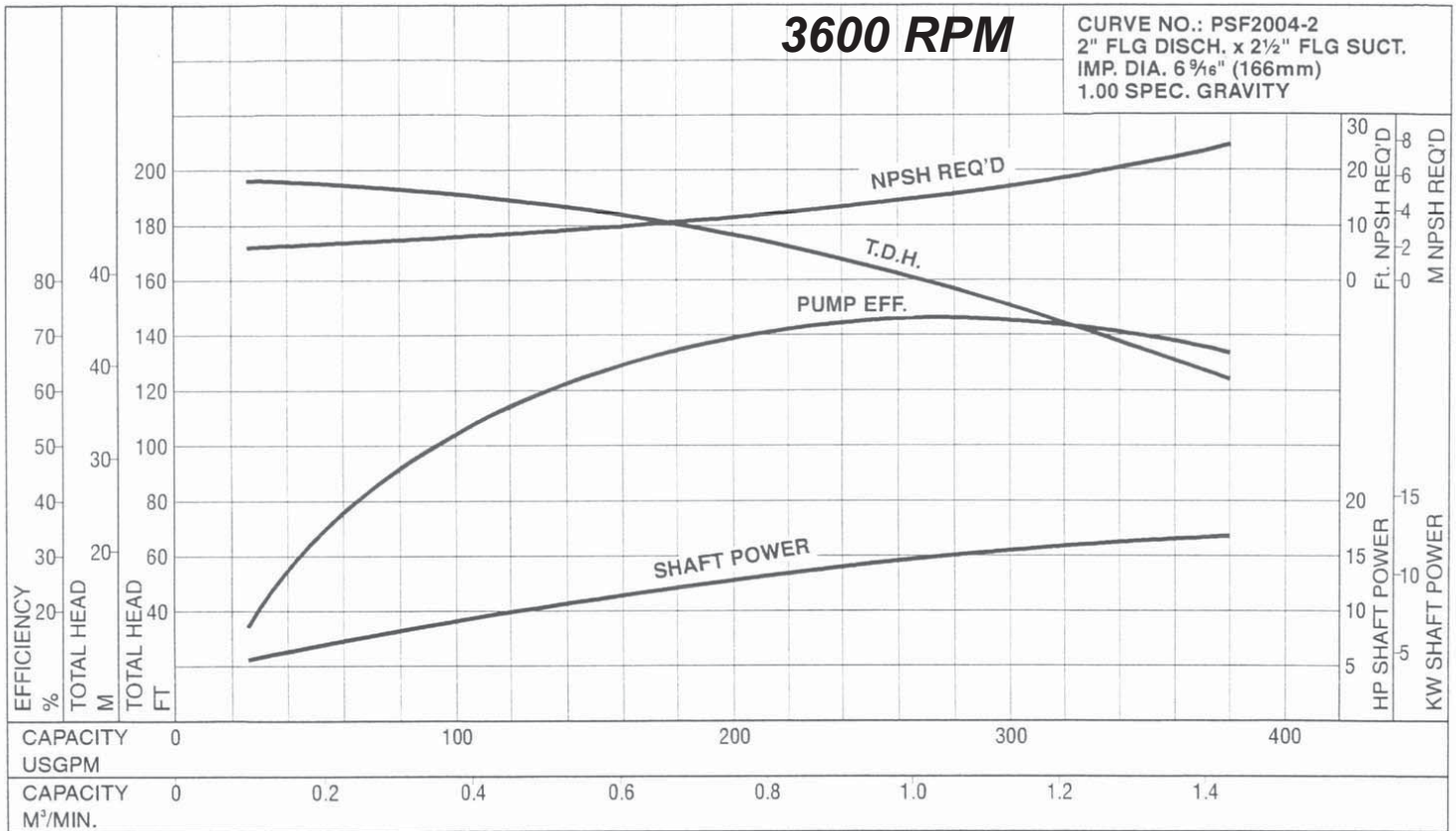





**FLO-FAB**  
Montréal, Québec

# SERIES PS Performance Curve MODEL - PSF3001

Synchronous Speed - 3450 RPM

2-1/2" Discharge x 3" Suction

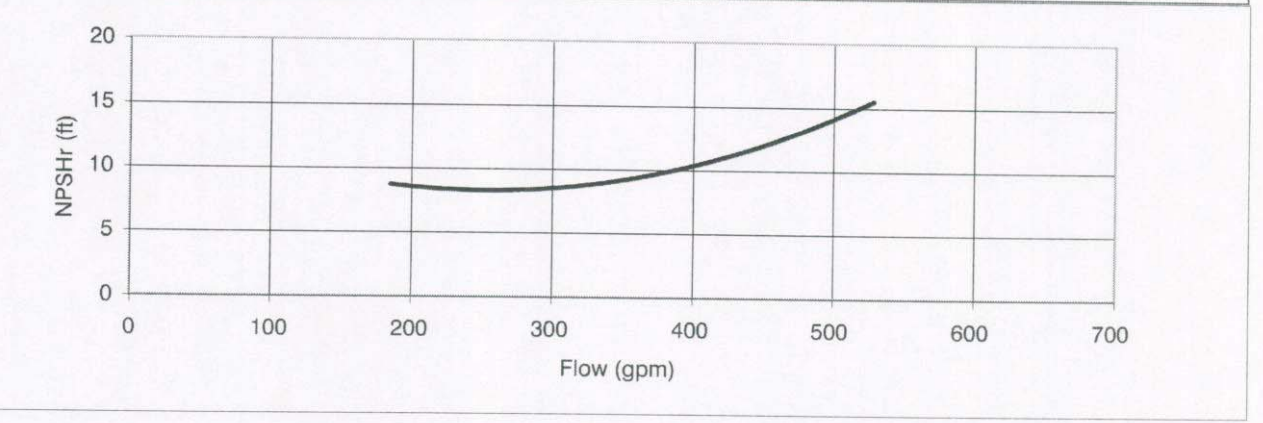
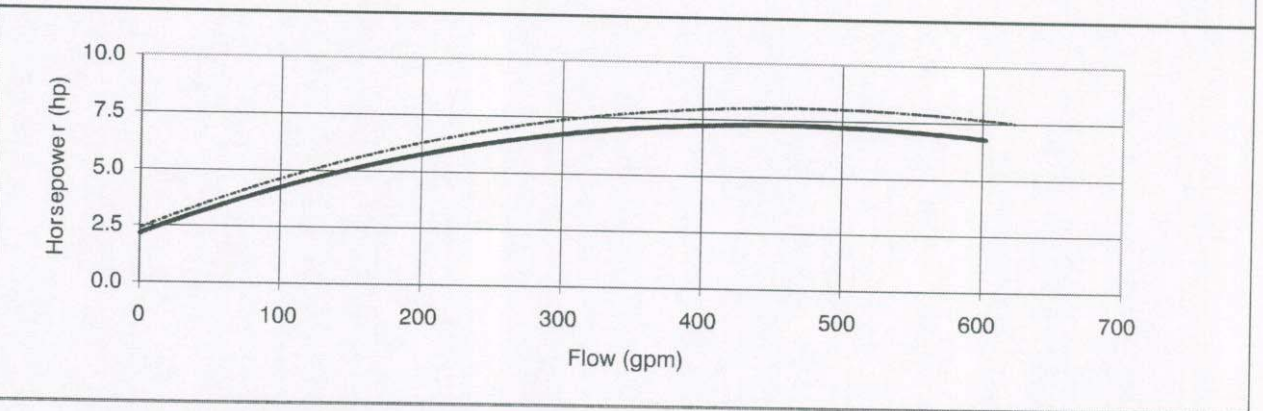
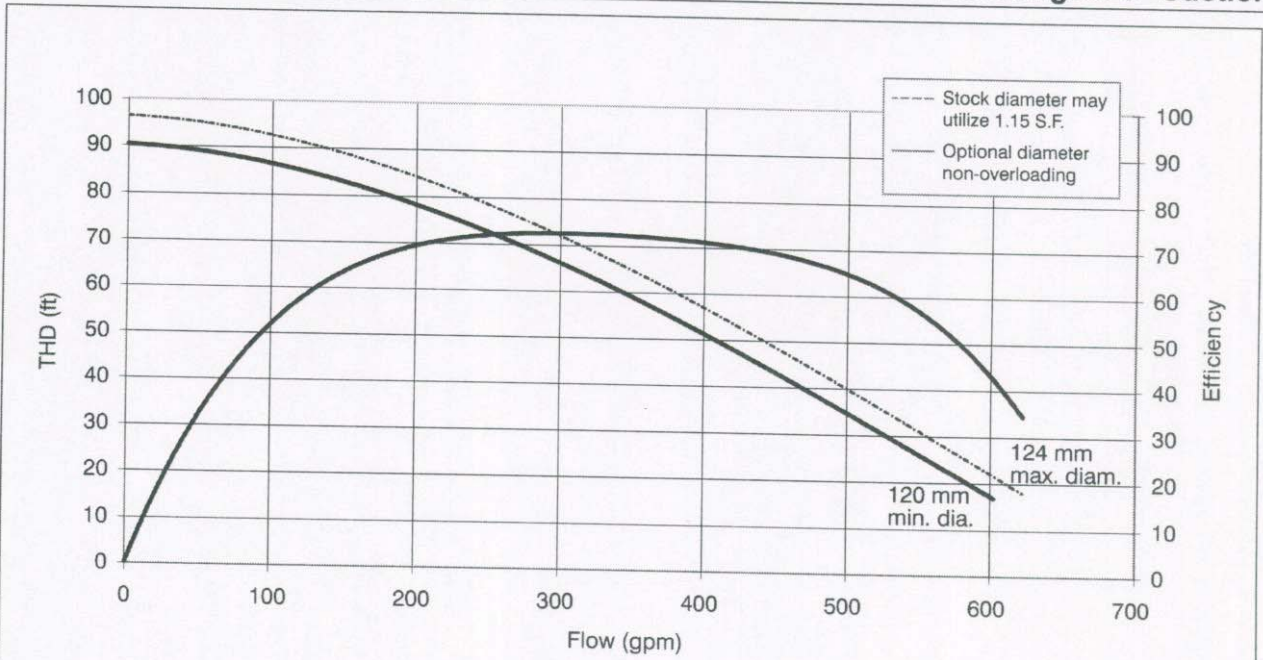



**FLO-FAB**  
Montréal, Québec

**SERIES PS**  
**Performance Curve**  
**MODEL - PSF3002**

**Synchronous Speed - 3450 RPM**

**2-1/2" Discharge x 3" Suction**

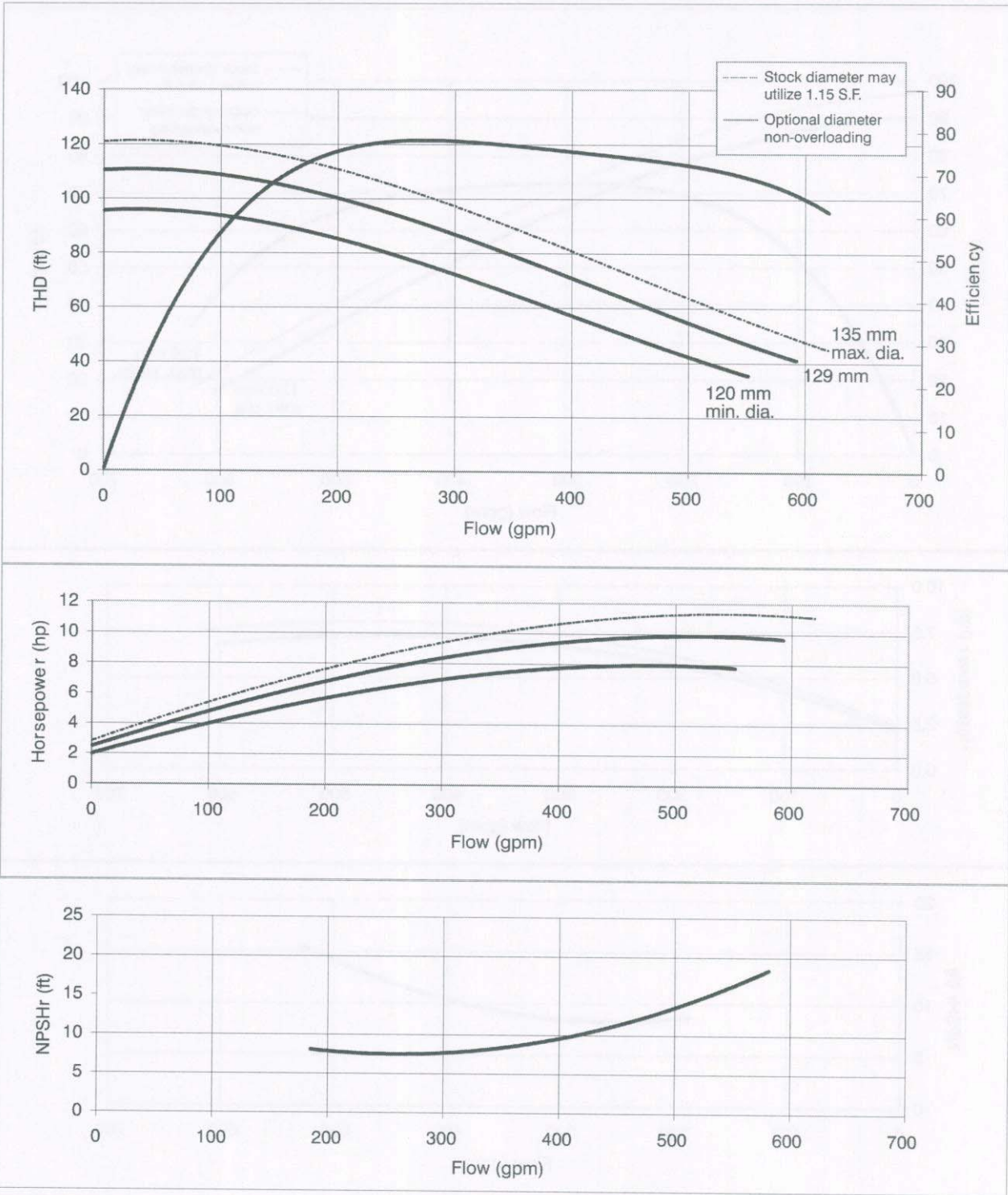





**FLO-FAB**  
Montréal, Québec

# SERIES PS Performance Curve MODEL - PSF3003

Synchronous Speed - 3450 RPM

2-1/2" Discharge x 3" Suction

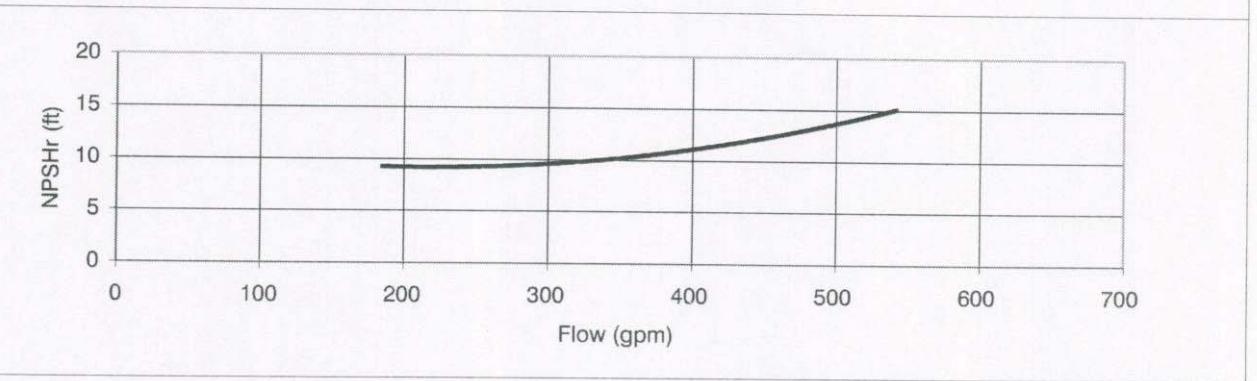
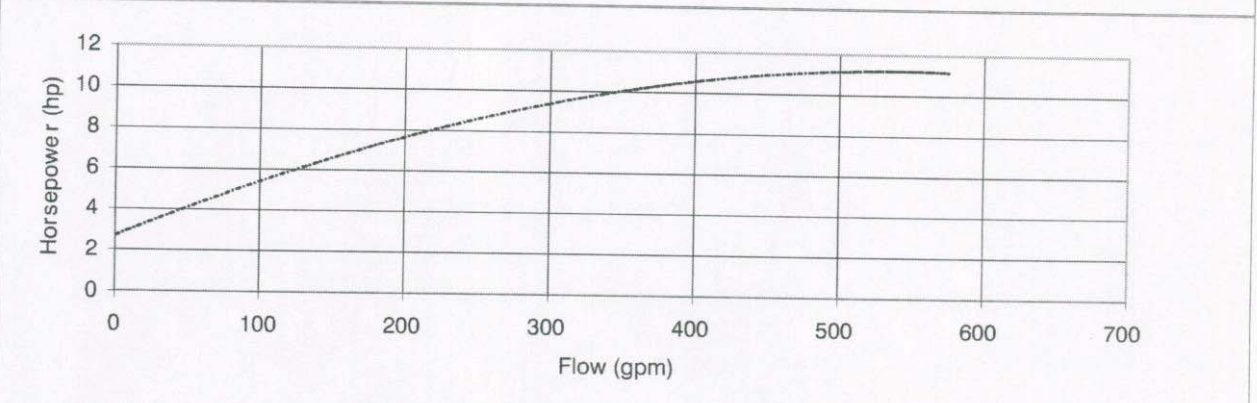
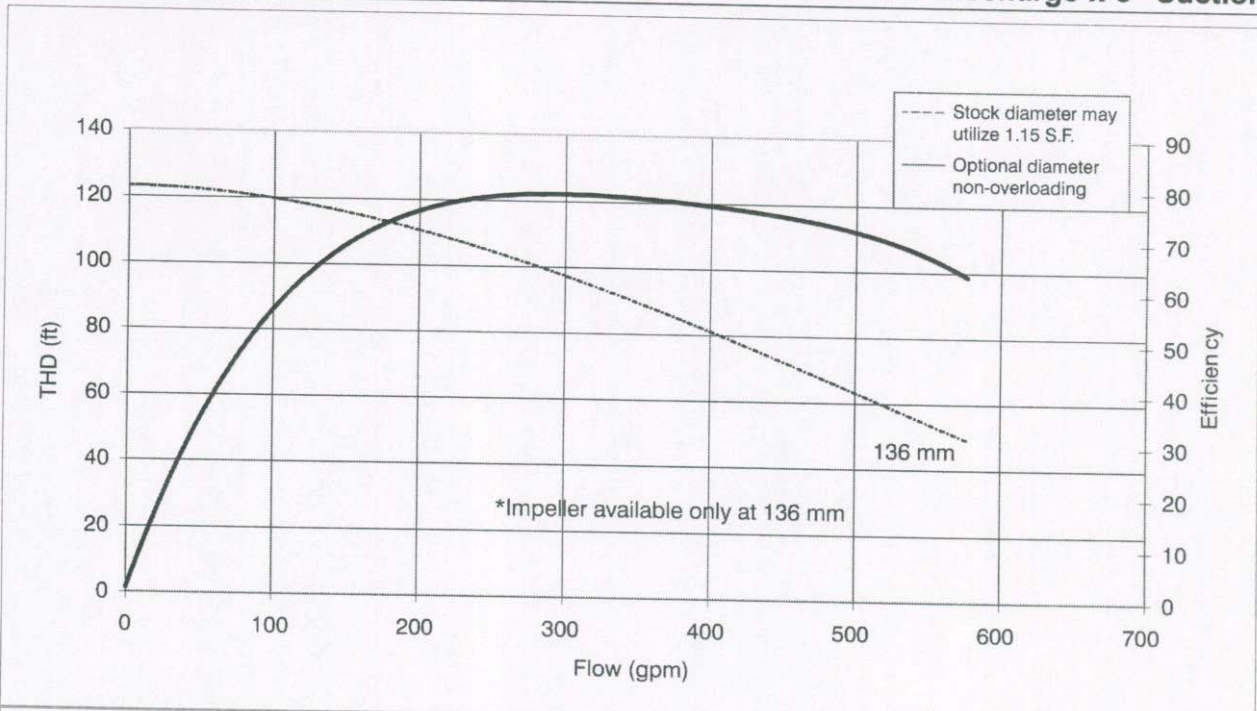



**FLO-FAB**  
Montréal, Québec

**SERIES PS**  
**Performance Curve**  
**MODEL - PSF3004**

**Synchronous Speed - 3450 RPM**

**2-1/2" Discharge x 3" Suction**

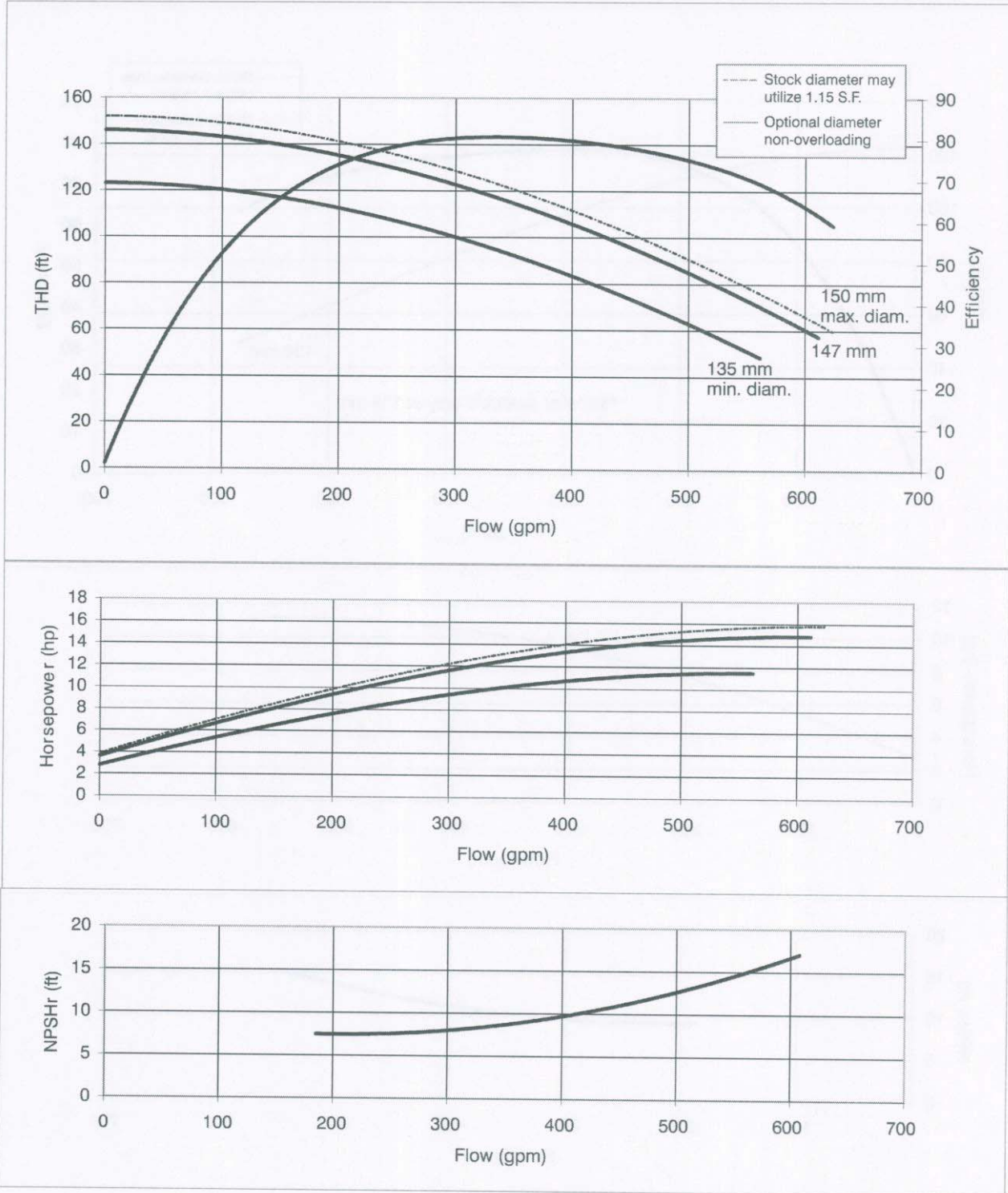



**Synchronous Speed - 3450 RPM**

**2-1/2" Discharge x 3" Suction**

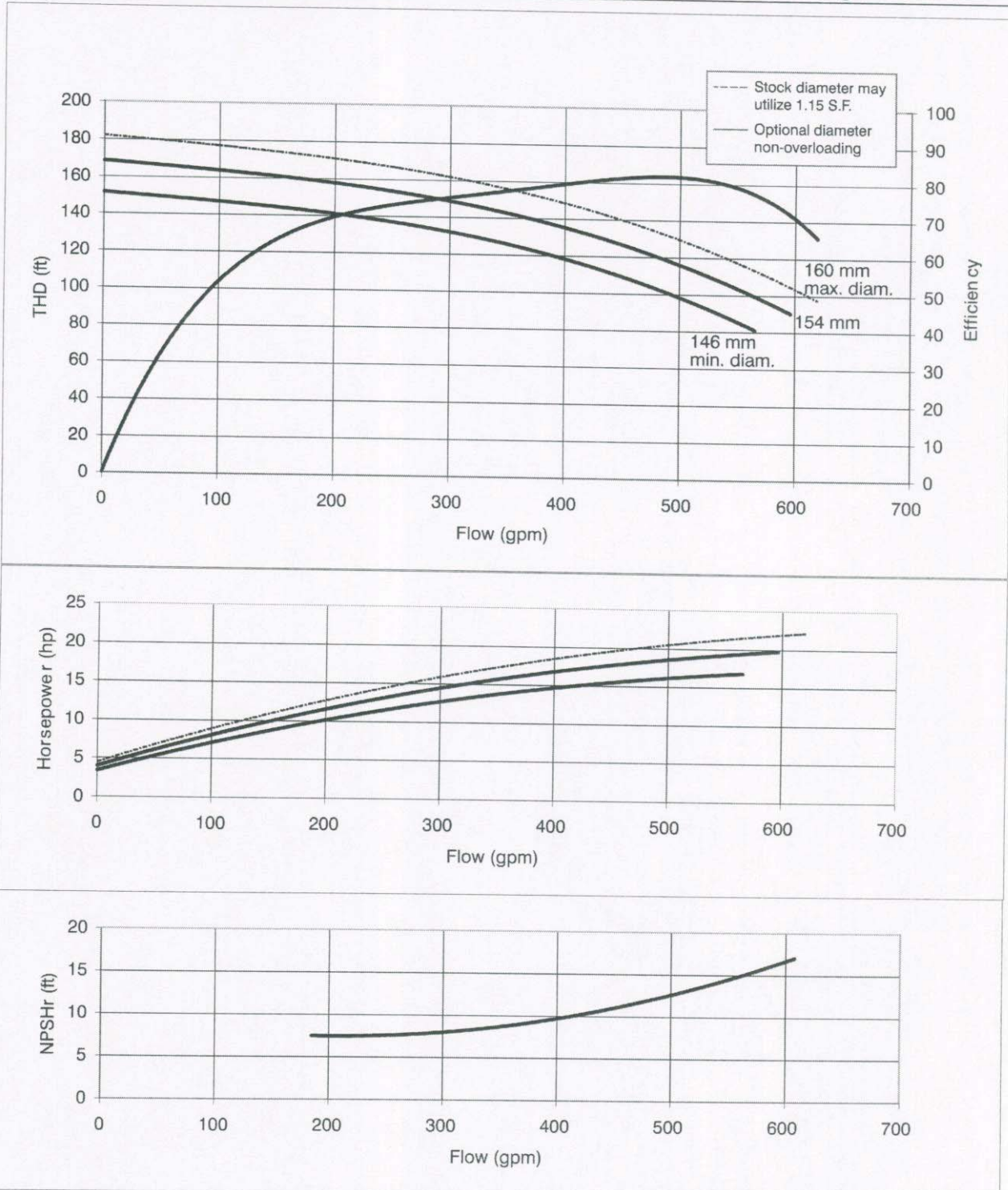



**FLO-FAB**  
Montréal, Québec

**SERIES PS**  
**Performance Curve**  
**MODEL - PSF3006**

**Synchronous Speed - 3450 RPM**

**2-1/2" Discharge x 3" Suction**

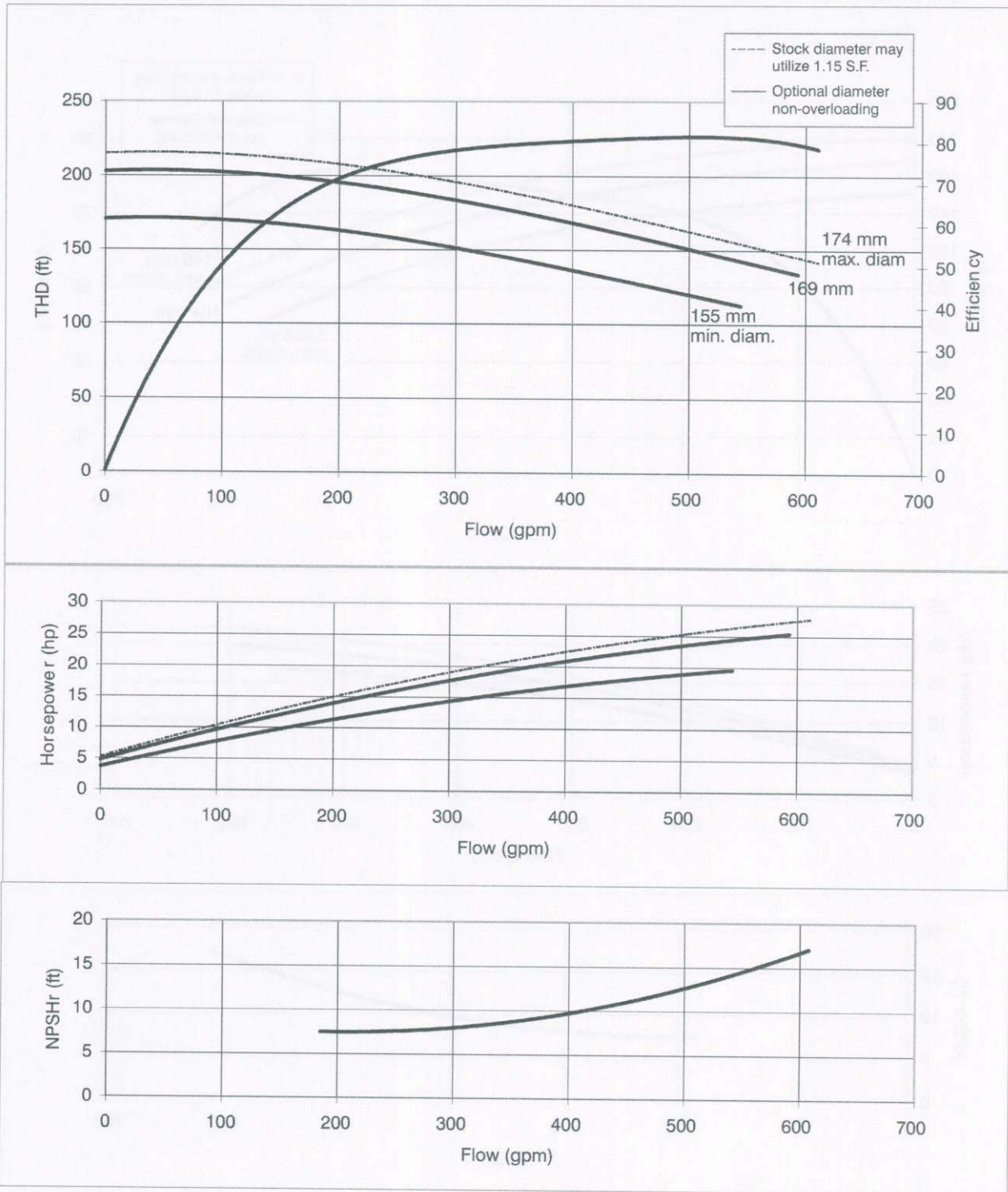





**FLO-FAB**  
Montréal, Québec

# SERIES PS Performance Curve MODEL - PSF3007

Synchronous Speed - 3450 RPM

2-1/2" Discharge x 3" Suction

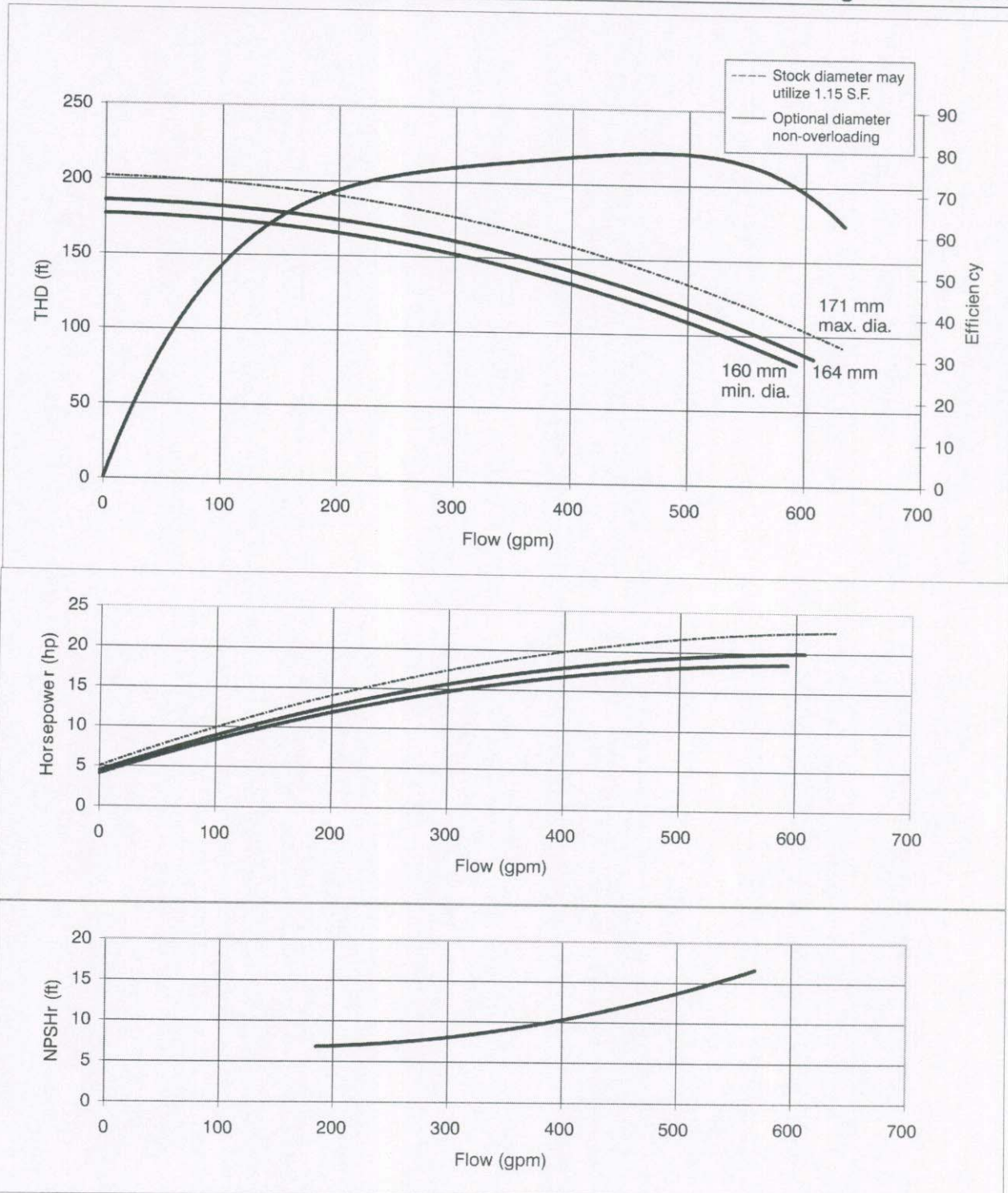





**FLO-FAB**  
Montréal, Québec

# SERIES PS

## Performance Curve

### MODEL - PSF3008

Synchronous Speed - 3450 RPM

2-1/2" Discharge x 3" Suction

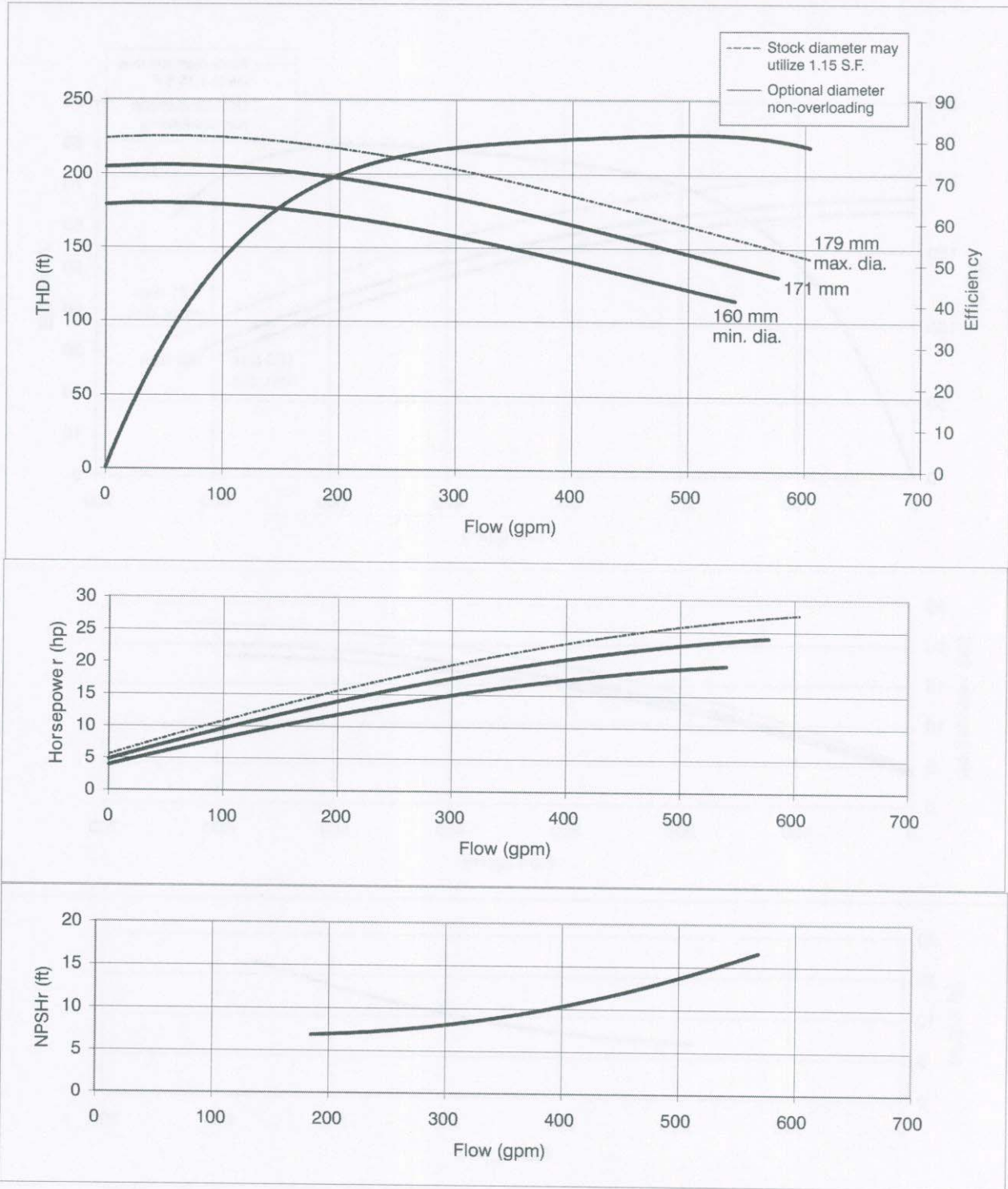



**FLO-FAB**  
Montréal, Québec

# SERIES PS Performance Curve MODEL - PSF3009

Synchronous Speed - 3450 RPM

2-1/2" Discharge x 3" Suction

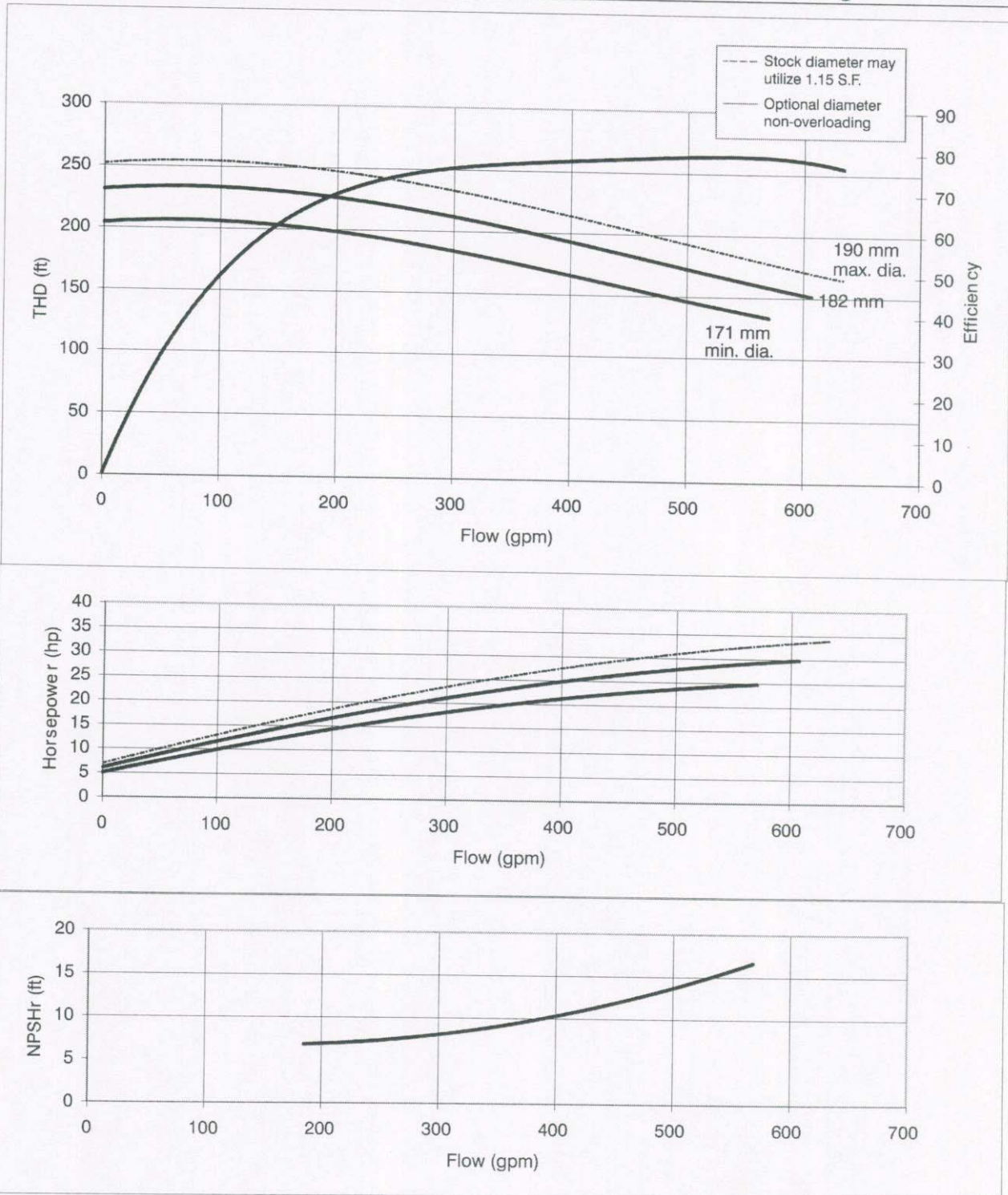

# FLOFAB

## SERIES PS Parts List MODEL - PSF701

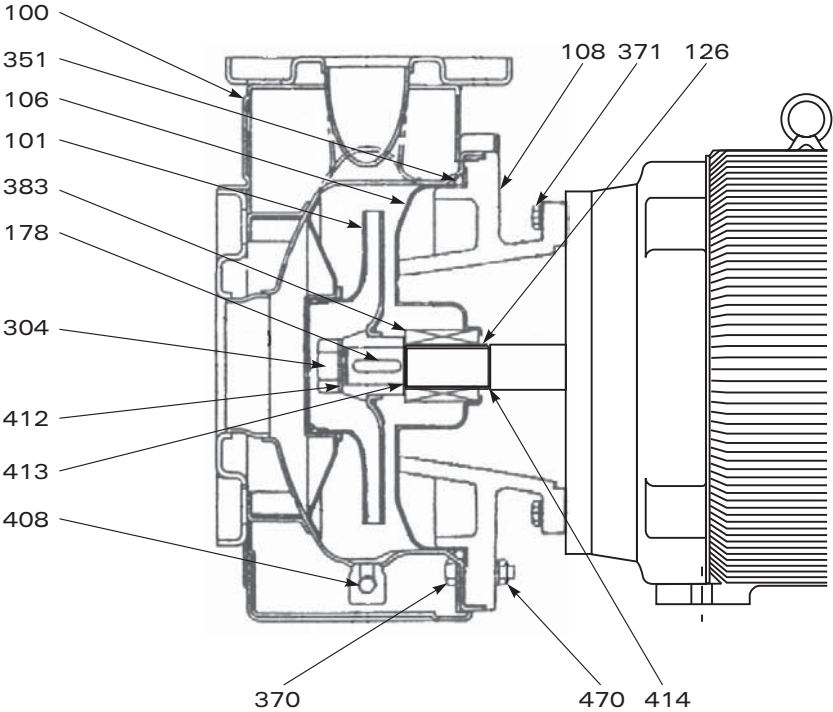

ITEM	QTY REQ'D	DESCRIPTION	MATERIAL	PART NUMBER
100	1	Casing	304 Stainless steel	E-251402201
101	1	Impeller	304 Stainless steel	E-251450866
106	1	Casing cover	304 Stainless steel	E-251438023
108	1	Adapter	Cast Iron	E-240080580
126	1	Shaft sleeve	304 Stainless steel	E-275416013
178	1	Impeller key	Steel	E-316X316
304	1	Impeller bolt	316 SS	E-275440031
351	1	Casing o-ring	Buna Viton	E-160X5.3B E-160X5.3V
370	8	Casing bolt	304 Stainless steel	E-M8X30HH
371	4	Motor bolt	Steel	E-3/8-16X3/4HH
383	1	Mechanical seal	Carbon/Ceramic/Buna Carbon/Ceramic/Viton Carbon/S.S./EPR Carbon/Carbide/Viton Carbide/Carbide/Viton	S18-2821-ABN S18-2821-AVT S18-2821-CEP S18-2821-BVT S18-2821-EVT
408	1	Casing plug	304 Stainless steel	E-363631000
412	1	Impeller gasket	Teflon	E-275476030
413	1	Sleeve gasket	Teflon	E-275476029
414	1	Sleeve gasket	Teflon	E-275476028
470	8	Casing bolt nut	304 Stainless Steel	E-M8HN



# FLOFAB

## SERIES PS Parts List MODEL - PSF702

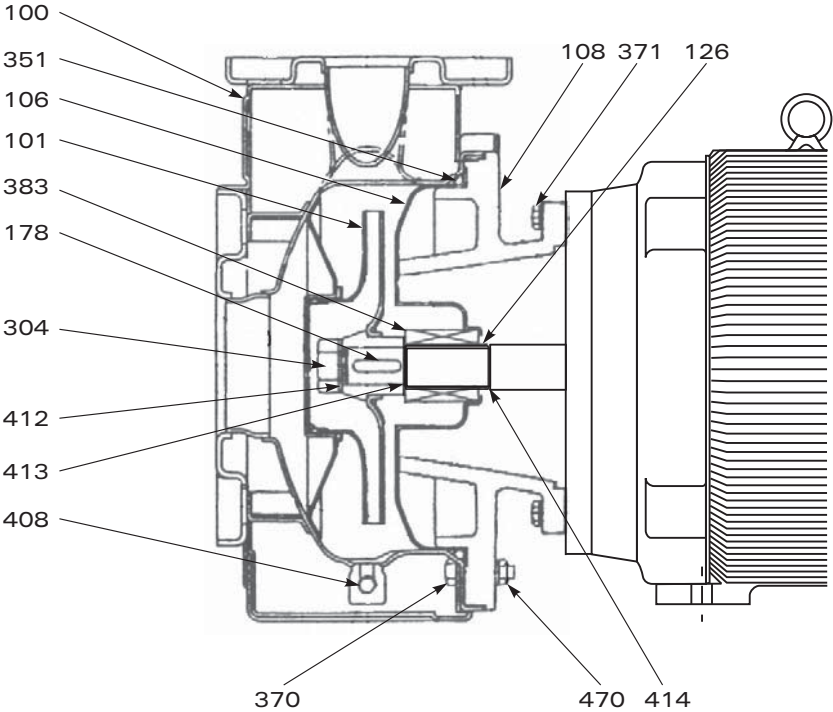

ITEM	QTY REQ'D	DESCRIPTION	MATERIAL	PART NUMBER
100	1	Casing	304 Stainless steel	E-251402202
101	1	Impeller	304 Stainless steel	E-251450867
106	1	Casing cover	304 Stainless steel	E-251438024
108	1	Adapter	Cast Iron	E-240080581
126	1	Shaft sleeve	304 Stainless steel	E-275416013
178	1	Impeller key	Steel	E-316X316
304	1	Impeller bolt	316 SS	E-275440031
351	1	Casing o-ring	Buna Viton	E-190X5.3B E-190X5.3V
370	10	Casing bolt	304 Stainless steel	E-M10X35HH
371	4	Motor bolt	Steel	E-3/8-16X1
383	1	Mechanical seal	Carbon/Ceramic/Buna Carbon/Ceramic/Viton Carbon/S.S./EPR Carbon/Carbide/Viton Carbide/Carbide/Viton	S18-2821-ABN S18-2821-AVT S18-2821-CEP S18-2821-BVT S18-2821-EVT
408	1	Casing plug	304 Stainless steel	E-363631000
412	1	Impeller gasket	Teflon	E-275476030
413	1	Sleeve gasket	Teflon	E-275476029
414	1	Sleeve gasket	Teflon	E-275476028
470	10	Casing bolt nut	304 Stainless Steel	E-M10HN

# FLOFAB

## SERIES PS Parts List MODEL - PSF703

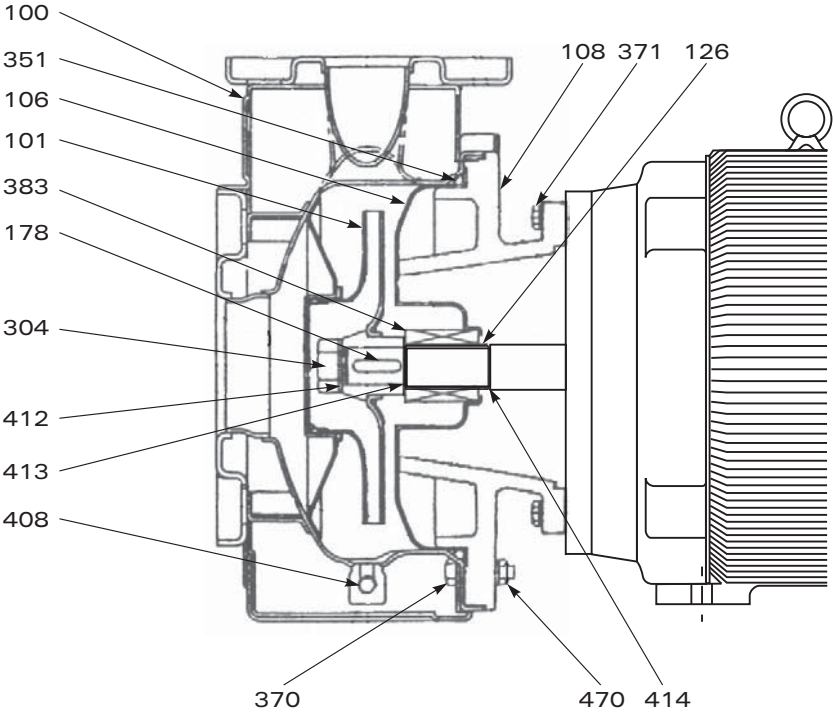

ITEM	QTY REQ'D	DESCRIPTION	MATERIAL	PART NUMBER
100	1	Casing	304 Stainless steel	E-251402202
101	1	Impeller	304 Stainless steel	E-251450868
106	1	Casing cover	304 Stainless steel	E-251438024
108	1	Adapter	Cast Iron	E-240080581
126	1	Shaft sleeve	304 Stainless steel	E-275416013
178	1	Impeller key	Steel	E-316X316
304	1	Impeller bolt	316 SS	E-275440031
351	1	Casing o-ring	Buna Viton	E-190X5.3B E-190X5.3V
370	10	Casing bolt	304 Stainless steel	E-M10X35HH
371	4	Motor bolt	Steel	E-3/8-16X1
383	1	Mechanical seal	Carbon/Ceramic/Buna Carbon/Ceramic/Viton Carbon/S.S./EPR Carbon/Carbide/Viton Carbide/Carbide/Viton	S18-2821-ABN S18-2821-AVT S18-2821-CEP S18-2821-BVT S18-2821-EVT
408	1	Casing plug	304 Stainless steel	E-363631000
412	1	Impeller gasket	Teflon	E-275476030
413	1	Sleeve gasket	Teflon	E-275476029
414	1	Sleeve gasket	Teflon	E-275476028
470	10	Casing bolt nut	304 Stainless Steel	E-M10HN

# FLOFAB

## SERIES PS Parts List MODEL - PSF704

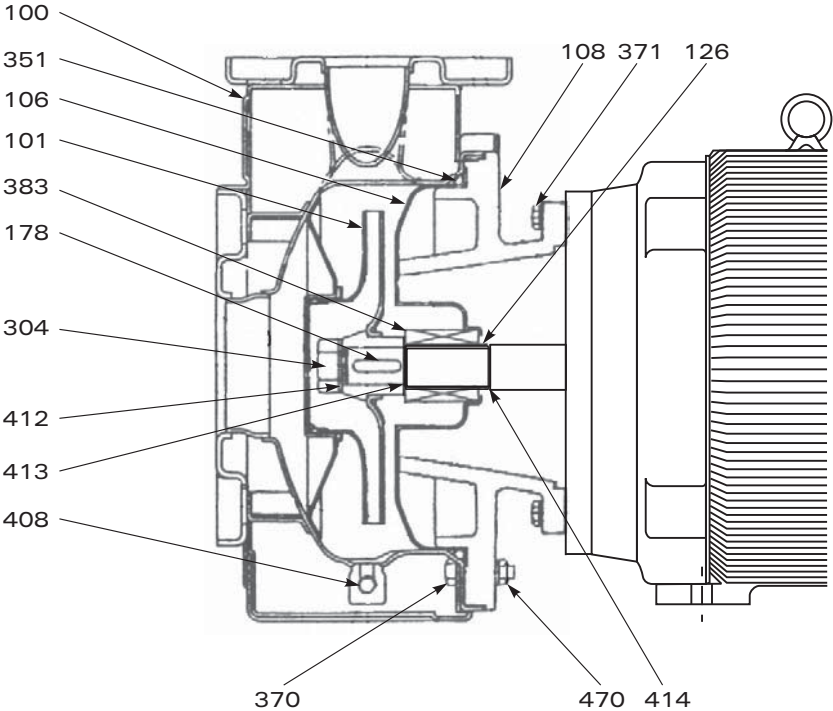

ITEM	QTY REQ'D	DESCRIPTION	MATERIAL	PART NUMBER
100	1	Casing	304 Stainless steel	E-251402203
101	1	Impeller	304 Stainless steel	E-251450869
106	1	Casing cover	304 Stainless steel	E-251402220
108	1	Adapter	C.I. (up to 184JM)	E-240080583
			C.I. (213JM and up)	E-240080584
126	1	Shaft sleeve	304 Stainless steel	E-275416013
178	1	Impeller key	Steel	E-316X316
304	1	Impeller bolt	316 SS	E-275440031
351	1	Casing o-ring	Buna	E-230X5.3B
			Viton	E-230X5.3V
370	12	Casing bolt	304 Stainless steel	E-M10X30HH
371	4	Motor bolt	Steel	E-1/2-13X1-1/2
383	1	Mechanical seal	Carbon/Ceramic/Buna	S18-2821-ABN
			Carbon/Ceramic/Viton	S18-2821-AVT
			Carbon/S.S./EPR	S18-2821-CEP
			Carbon/Carbide/Viton	S18-2821-BVT
			Carbide/Carbide/Viton	S18-2821-EVT
408	1	Casing plug	304 Stainless steel	E-363631000
412	1	Impeller gasket	Teflon	E-275476030
413	1	Sleeve gasket	Teflon	E-275476029
414	1	Sleeve gasket	Teflon	E-275476028
470	12	Casing bolt nut	304 Stainless Steel	E-M10HN

# FLOFAB

## SERIES PS Parts List MODEL - PSF705

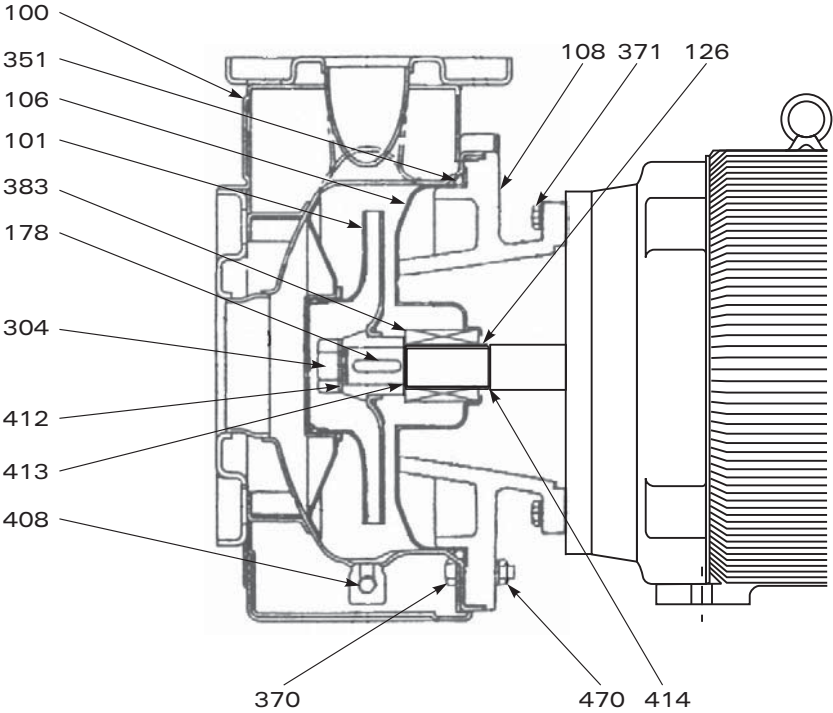

ITEM	QTY REQ'D	DESCRIPTION	MATERIAL	PART NUMBER
100	1	Casing	304 Stainless steel	E-251402203
101	1	Impeller	304 Stainless steel	E-251450870
106	1	Casing cover	304 Stainless steel	E-251402220
108	1	Adapter	C.I. (up to 184JM)	E-240080583
			C.I. (213JM and up)	E-240080584
126	1	Shaft sleeve	304 Stainless steel	E-275416013
178	1	Impeller key	Steel	E-316X316
304	1	Impeller bolt	316 SS	E-275440031
351	1	Casing o-ring	Buna	E-230X5.3B
			Viton	E-230X5.3V
370	12	Casing bolt	304 Stainless steel	E-M10X35HH
371	4	Motor bolt	Steel	E-1/2-13X1-1/2
383	1	Mechanical seal	Carbon/Ceramic/Buna	S18-2821-ABN
			Carbon/Ceramic/Viton	S18-2821-AVT
			Carbon/S.S./EPR	S18-2821-CEP
			Carbon/Carbide/Viton	S18-2821-BVT
			Carbide/Carbide/Viton	S18-2821-EVT
408	1	Casing plug	304 Stainless steel	E-363631000
412	1	Impeller gasket	Teflon	E-275476030
413	1	Sleeve gasket	Teflon	E-275476029
414	1	Sleeve gasket	Teflon	E-275476028
470	12	Casing bolt nut	304 Stainless Steel	E-M10HN





**SERIES PS**  
**Parts List**  
**MODEL - PSF1201**

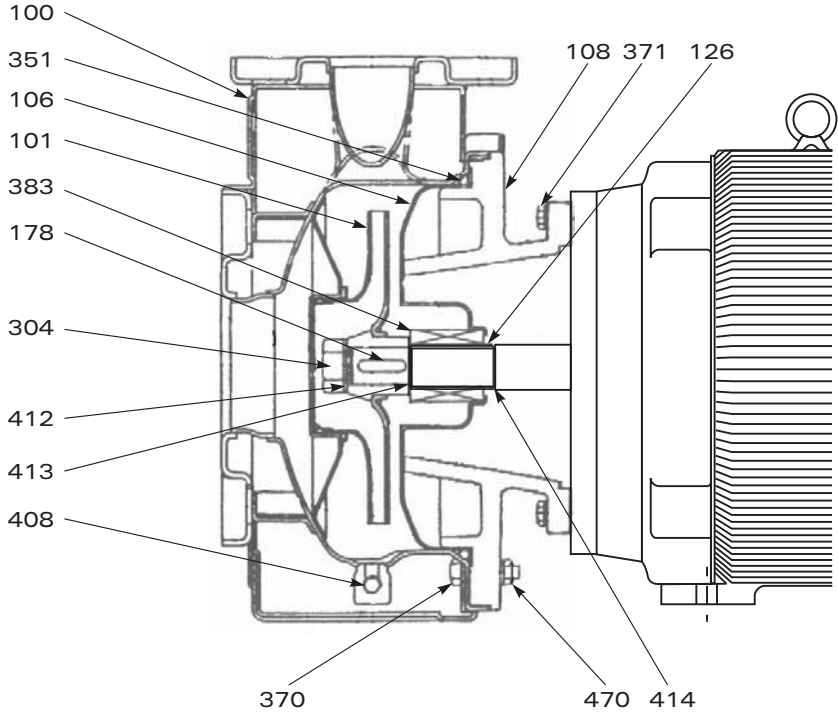

ITEM	QTY REQ'D	DESCRIPTION	MATERIAL	PART NUMBER
100	1	Casing	304 Stainless steel	E-251402204
101	1	Impeller	304 Stainless steel	E-251450871
106	1	Casing cover	304 Stainless steel	E-251438023
108	1	Adapter	Cast Iron	E-240080580
126	1	Shaft sleeve	304 Stainless steel	E-275416013
178	1	Impeller key	Steel	E-316X316
304	1	Impeller bolt	316 SS	E-275440031
351	1	Casing o-ring	Buna	E-160X5.3B
			Viton	E-160X5.3V
370	8	Casing bolt	304 Stainless steel	E-M8X30HH
371	4	Motor bolt	Steel	E-3/8-16X3/4HH
383	1	Mechanical seal	Carbon/Ceramic/Buna	S18-2821-ABN
			Carbon/Ceramic/Viton	S18-2821-AVT
			Carbon/S.S./EPR	S18-2821-CEP
			Carbon/Carbide/Viton	S18-2821-BVT
			Carbide/Carbide/Viton	S18-2821-EVT
408	1	Casing plug	304 Stainless steel	E-363631000
412	1	Impeller gasket	Teflon	E-275476030
413	1	Sleeve gasket	Teflon	E-275476029
414	1	Sleeve gasket	Teflon	E-275476028
470	8	Casing bolt nut	304 Stainless Steel	E-M8HN

# FLOFAB

## SERIES PS Parts List MODEL - PSF1202

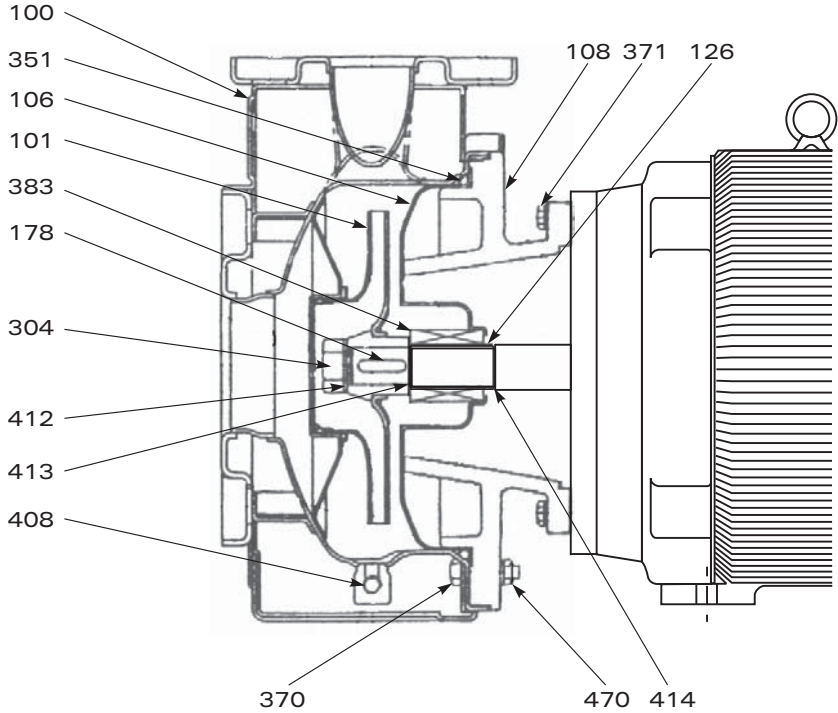

ITEM	QTY REQ'D	DESCRIPTION	MATERIAL	PART NUMBER
100	1	Casing	304 Stainless steel	E-251402204
101	1	Impeller	304 Stainless steel	E-251450872
106	1	Casing cover	304 Stainless steel	E-251438023
108	1	Adapter	Cast Iron	E-240080580
126	1	Shaft sleeve	304 Stainless steel	E-275416013
178	1	Impeller key	Steel	E-316X316
304	1	Impeller bolt	316 SS	E-275440031
351	1	Casing o-ring	Buna	E-160X5.3B
			Viton	E-160X5.3V
370	8	Casing bolt	304 Stainless steel	E-M8X30HH
371	4	Motor bolt	Steel	E-3/8-16X3/4HH
383	1	Mechanical seal	Carbon/Ceramic/Buna	S18-2821-ABN
			Carbon/Ceramic/Viton	S18-2821-AVT
			Carbon/S.S./EPR	S18-2821-CEP
			Carbon/Carbide/Viton	S18-2821-BVT
			Carbide/Carbide/Viton	S18-2821-EVT
408	1	Casing plug	304 Stainless steel	E-363631000
412	1	Impeller gasket	Teflon	E-275476030
413	1	Sleeve gasket	Teflon	E-275476029
414	1	Sleeve gasket	Teflon	E-275476028
470	8	Casing bolt nut	304 Stainless Steel	E-M8HN

# FLOFAB

## SERIES PS Parts List MODEL - PSF1203

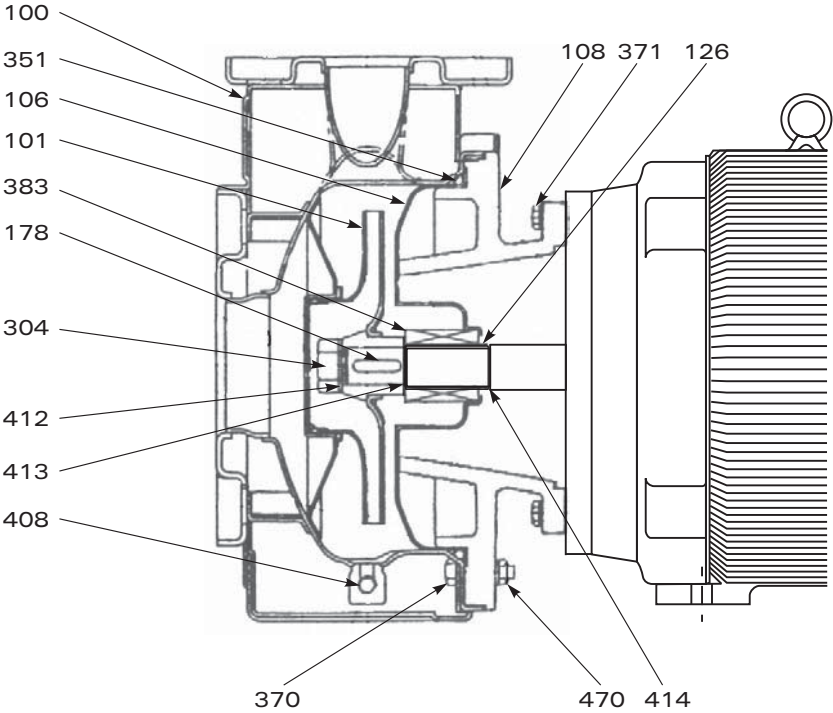

ITEM	QTY REQ'D	DESCRIPTION	MATERIAL	PART NUMBER
100	1	Casing	304 Stainless steel	E-251402205
101	1	Impeller	304 Stainless steel	E-251450873
106	1	Casing cover	304 Stainless steel	E-251438024
108	1	Adapter	C.I. (up to 184JM)	E-240080581
			C.I. (213JM and up)	E-240080582
126	1	Shaft sleeve	304 Stainless steel	E-275416013
178	1	Impeller key	Steel	E-316X316
304	1	Impeller bolt	316 SS	E-275440031
351	1	Casing o-ring	Buna	E-190X5.3B
			Viton	E-190X5.3V
370	10	Casing bolt	304 Stainless steel	E-M10X35HH
371	4	Motor bolt	Steel	E-3/8-16X1-3/4
383	1	Mechanical seal	Carbon/Ceramic/Buna	S18-2821-ABN
			Carbon/Ceramic/Viton	S18-2821-AVT
			Carbon/S.S./EPR	S18-2821-CEP
			Carbon/Carbide/Viton	S18-2821-BVT
			Carbide/Carbide/Viton	S18-2821-EVT
408	1	Casing plug	304 Stainless steel	E-363631000
412	1	Impeller gasket	Teflon	E-275476030
413	1	Sleeve gasket	Teflon	E-275476029
414	1	Sleeve gasket	Teflon	E-275476028
470	10	Casing bolt nut	304 Stainless Steel	E-M10HN

# FLOFAB

## SERIES PS Parts List MODEL - PSF1204

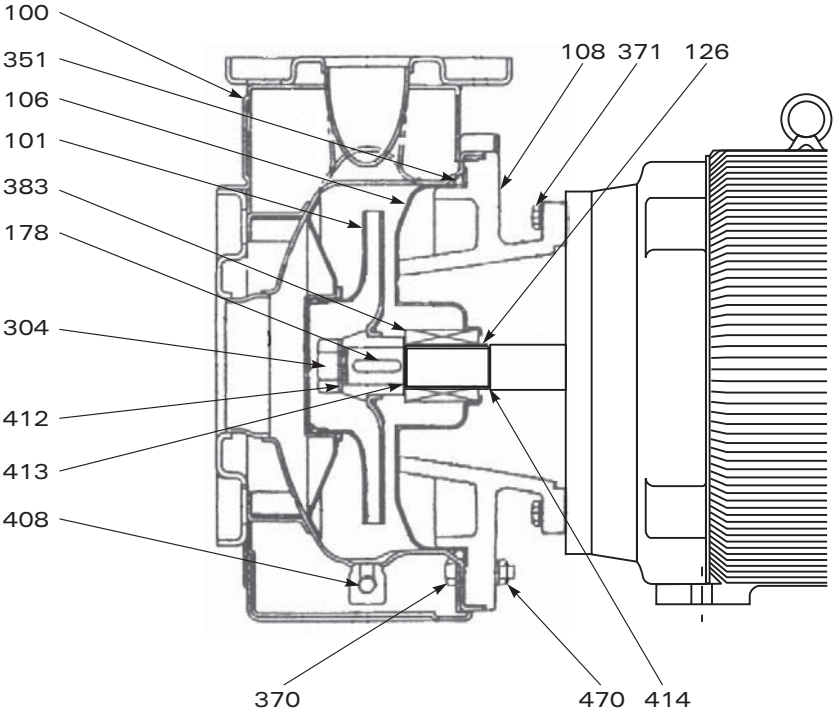

ITEM	QTY REQ'D	DESCRIPTION	MATERIAL	PART NUMBER
100	1	Casing	304 Stainless steel	E-251402205
101	1	Impeller	304 Stainless steel	E-251450874
106	1	Casing cover	304 Stainless steel	E-251438024
108	1	Adapter	C.I. (up to 184JM)	E-240080581
			C.I. (213JM and up)	E-240080582
126	1	Shaft sleeve	304 Stainless steel	E-275416013
178	1	Impeller key	Steel	E-316X316
304	1	Impeller bolt	316 SS	E-275440031
351	1	Casing o-ring	Buna	E-190X5.3B
			Viton	E-190X5.3V
370	10	Casing bolt	304 Stainless steel	E-M10X35HH
371	4	Motor bolt	Steel	E-1/2-13X1-3/4
383	1	Mechanical seal	Carbon/Ceramic/Buna	S18-2821-ABN
			Carbon/Ceramic/Viton	S18-2821-AVT
			Carbon/S.S./EPR	S18-2821-CEP
			Carbon/Carbide/Viton	S18-2821-BVT
			Carbide/Carbide/Viton	S18-2821-EVT
408	1	Casing plug	304 Stainless steel	E-363631000
412	1	Impeller gasket	Teflon	E-275476030
413	1	Sleeve gasket	Teflon	E-275476029
414	1	Sleeve gasket	Teflon	E-275476028
470	10	Casing bolt nut	304 Stainless Steel	E-M10HN

# FLOFAB

## SERIES PS Parts List MODEL - PSF1205

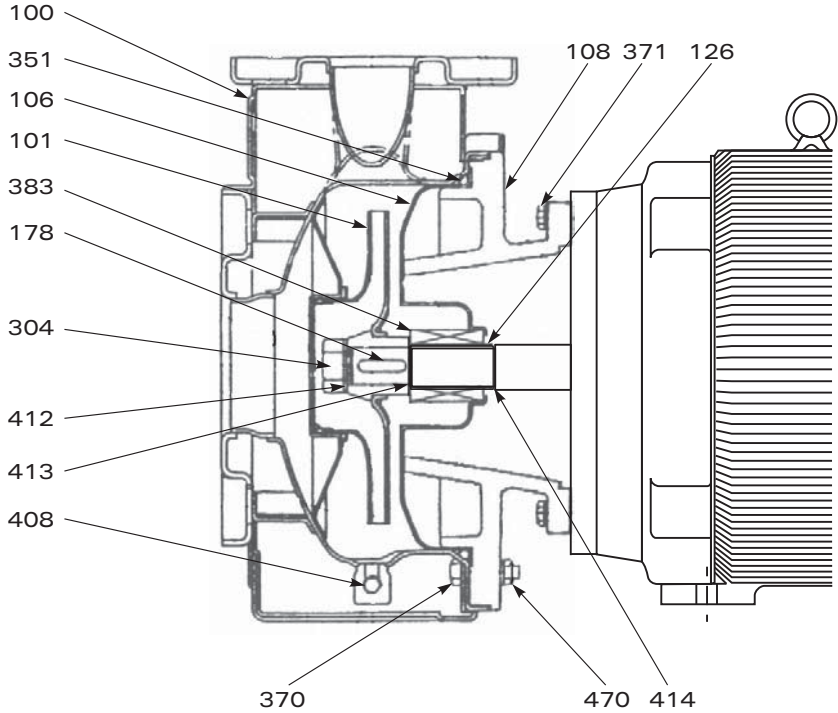

ITEM	QTY REQ'D	DESCRIPTION	MATERIAL	PART NUMBER
100	1	Casing	304 Stainless steel	E-251402206
101	1	Impeller	304 Stainless steel	E-251450875
106	1	Casing cover	304 Stainless steel	E-251402220
108	1	Adapter	C.I. (up to 184JM)	E-240080583
			C.I. (213JM and up)	E-240080584
126	1	Shaft sleeve	304 Stainless steel	E-275416013
178	1	Impeller key	Steel	E-316X316
304	1	Impeller bolt	316 SS	E-275440031
351	1	Casing o-ring	Buna	E-230X5.3B
			Viton	E-230X5.3V
370	12	Casing bolt	304 Stainless steel	E-M10X35HH
371	4	Motor bolt	Steel	E-1/2-13X1-1/2
383	1	Mechanical seal	Carbon/Ceramic/Buna	S18-2821-ABN
			Carbon/Ceramic/Viton	S18-2821-AVT
			Carbon/S.S./EPR	S18-2821-CEP
			Carbon/Carbide/Viton	S18-2821-BVT
			Carbide/Carbide/Viton	S18-2821-EVT
408	1	Casing plug	304 Stainless steel	E-363631000
412	1	Impeller gasket	Teflon	E-275476030
413	1	Sleeve gasket	Teflon	E-275476029
414	1	Sleeve gasket	Teflon	E-275476028
470	12	Casing bolt nut	304 Stainless Steel	E-M10HN

# FLOFAB

## SERIES PS Parts List MODEL - PSF1206

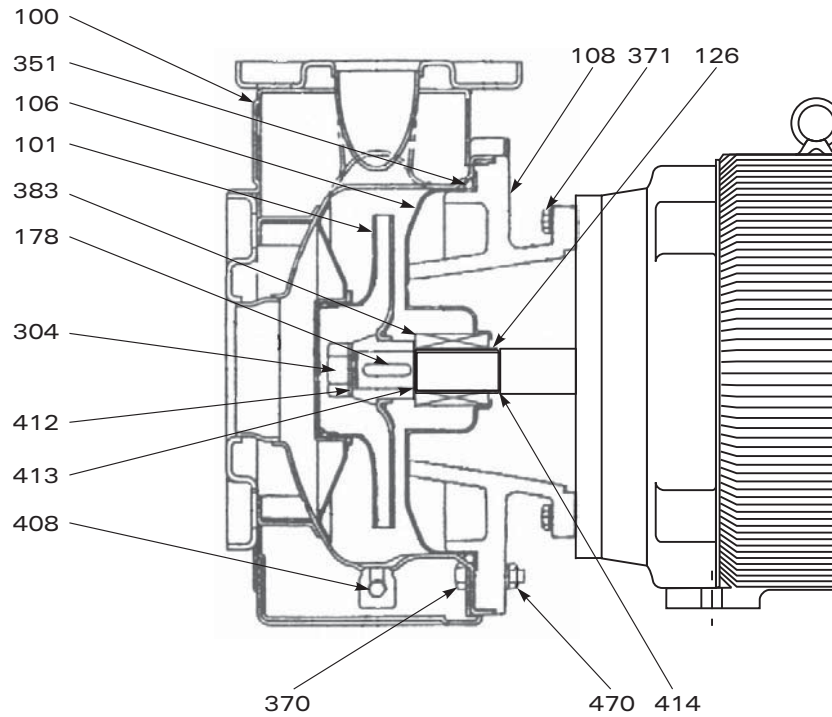

ITEM	QTY REQ'D	DESCRIPTION	MATERIAL	PART NUMBER
100	1	Casing	304 Stainless steel	E-251402206
101	1	Impeller	304 Stainless steel	E-251450876
106	1	Casing cover	304 Stainless steel	E-251402220
108	1	Adapter	C.I. (up to 184JM)	E-240080583
			C.I. (213JM and up)	E-240080584
126	1	Shaft sleeve	304 Stainless steel	E-275416013
178	1	Impeller key	Steel	E-316X316
304	1	Impeller bolt	316 SS	E-275440031
351	1	Casing o-ring	Buna	E-230X5.3B
			Viton	E-230X5.3V
370	12	Casing bolt	304 Stainless steel	E-M10X35HH
371	4	Motor bolt	Steel	E-1/2-13X1-1/2
383	1	Mechanical seal	Carbon/Ceramic/Buna	S18-2821-ABN
			Carbon/Ceramic/Viton	S18-2821-AVT
			Carbon/S.S./EPR	S18-2821-CEP
			Carbon/Carbide/Viton	S18-2821-BVT
			Carbide/Carbide/Viton	S18-2821-EVT
408	1	Casing plug	304 Stainless steel	E-363631000
412	1	Impeller gasket	Teflon	E-275476030
413	1	Sleeve gasket	Teflon	E-275476029
414	1	Sleeve gasket	Teflon	E-275476028
470	12	Casing bolt nut	304 Stainless Steel	E-M10HN

# FLOFAB

## SERIES PS Parts List MODEL - PSF2001

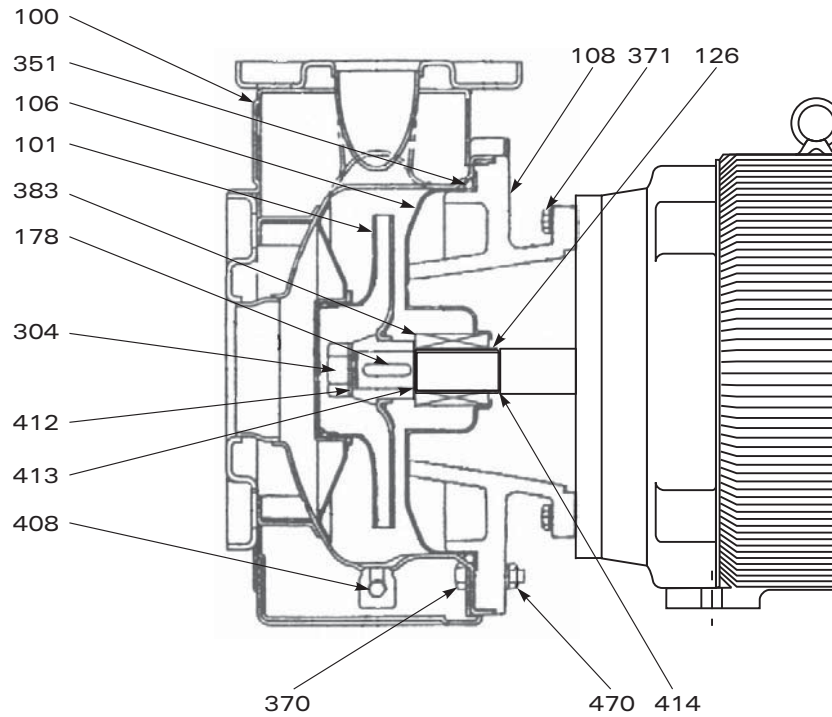

ITEM	QTY REQ'D	DESCRIPTION	MATERIAL	PART NUMBER
100	1	Casing	304 Stainless steel	E-251402207
101	1	Impeller	304 Stainless steel	E-251450877
106	1	Casing cover	304 Stainless steel	E-251438024
108	1	Adapter	C.I. (up to 184JM)	E-240080581
			C.I. (213JM and up)	E-240080582
126	1	Shaft sleeve	304 Stainless steel	E-275416013
178	1	Impeller key	Steel	E-316X316
304	1	Impeller bolt	316 SS	E-275440031
351	1	Casing o-ring	Buna	E-190X5.3B
			Viton	E-190X5.3V
370	10	Casing bolt	304 Stainless steel	E-M10X35HH
371	4	Motor bolt	Steel	E-1/2-13X1-3/4
383	1	Mechanical seal	Carbon/Ceramic/Buna	S18-2821-ABN
			Carbon/Ceramic/Viton	S18-2821-AVT
			Carbon/S.S./EPR	S18-2821-CEP
			Carbon/Carbide/Viton	S18-2821-BVT
			Carbide/Carbide/Viton	S18-2821-EVT
408	1	Casing plug	304 Stainless steel	E-363631000
412	1	Impeller gasket	Teflon	E-275476030
413	1	Sleeve gasket	Teflon	E-275476029
414	1	Sleeve gasket	Teflon	E-275476028
470	10	Casing bolt nut	304 Stainless Steel	E-M10HN



# FLOFAB

## SERIES PS Parts List MODEL - PSF2002

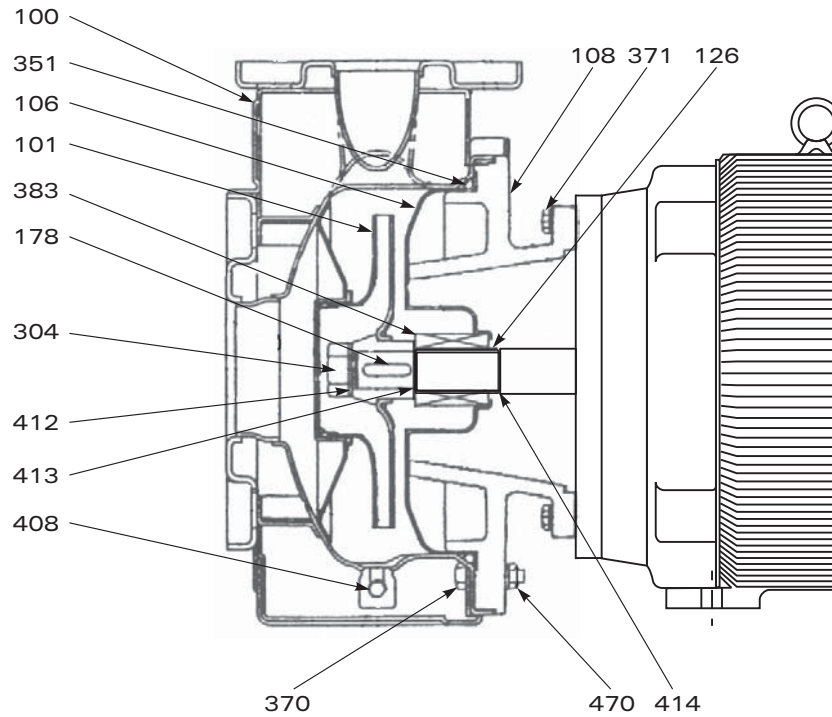

ITEM	QTY REQ'D	DESCRIPTION	MATERIAL	PART NUMBER
100	1	Casing	304 Stainless steel	E-251402207
101	1	Impeller	304 Stainless steel	E-251450878
106	1	Casing cover	304 Stainless steel	E-251438024
108	1	Adapter	C.I. (up to 184JM)	E-240080581
			C.I. (213JM and up)	E-240080582
126	1	Shaft sleeve	304 Stainless steel	E-275416013
178	1	Impeller key	Steel	E-316X316
304	1	Impeller bolt	316 SS	E-275440031
351	1	Casing o-ring	Buna	E-190X5.3B
			Viton	E-190X5.3V
370	10	Casing bolt	304 Stainless steel	E-M10X35HH
371	4	Motor bolt	Steel	E-1/2-13X1-3/4
383	1	Mechanical seal	Carbon/Ceramic/Buna	S18-2821-ABN
			Carbon/Ceramic/Viton	S18-2821-AVT
			Carbon/S.S./EPR	S18-2821-CEP
			Carbon/Carbide/Viton	S18-2821-BVT
			Carbide/Carbide/Viton	S18-2821-EVT
408	1	Casing plug	304 Stainless steel	E-363631000
412	1	Impeller gasket	Teflon	E-275476030
413	1	Sleeve gasket	Teflon	E-275476029
414	1	Sleeve gasket	Teflon	E-275476028
470	10	Casing bolt nut	304 Stainless Steel	E-M10HN

# FLOFAB

## SERIES PS Parts List MODEL - PSF2003

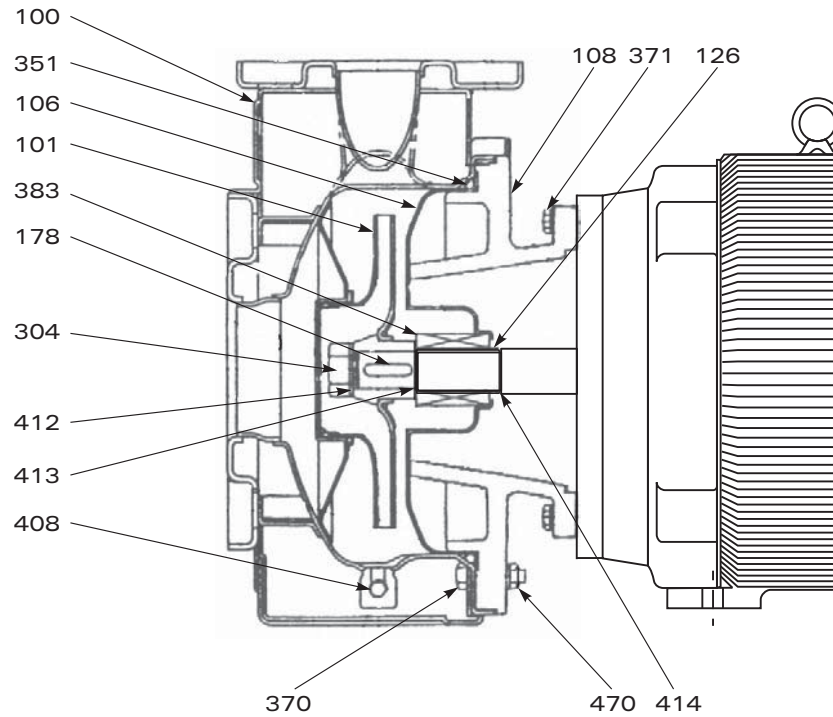

ITEM	QTY REQ'D	DESCRIPTION	MATERIAL	PART NUMBER
100	1	Casing	304 Stainless steel	E-251402208
101	1	Impeller	304 Stainless steel	E-251450879
106	1	Casing cover	304 Stainless steel	E-251402221
108	1	Adapter	C.I. (up to 184JM)	E-240080583
			C.I. (213JM and up)	E-240080584
126	1	Shaft sleeve	304 Stainless steel	E-275416013
178	1	Impeller key	Steel	E-316X316
304	1	Impeller bolt	316 SS	E-275440031
351	1	Casing o-ring	Buna	E-230X5.3B
			Viton	E-230X5.3V
370	12	Casing bolt	304 Stainless steel	E-M10X35HH
371	4	Motor bolt	Steel	E-1/2-13X1-1/2
383	1	Mechanical seal	Carbon/Ceramic/Buna	S18-2821-ABN
			Carbon/Ceramic/Viton	S18-2821-AVT
			Carbon/S.S./EPR	S18-2821-CEP
			Carbon/Carbide/Viton	S18-2821-BVT
			Carbide/Carbide/Viton	S18-2821-EVT
408	1	Casing plug	304 Stainless steel	E-363631000
412	1	Impeller gasket	Teflon	E-275476030
413	1	Sleeve gasket	Teflon	E-275476029
414	1	Sleeve gasket	Teflon	E-275476028
470	12	Casing bolt nut	304 Stainless Steel	E-M10HN

# FLOFAB

## SERIES PS Parts List MODEL - PSF2004

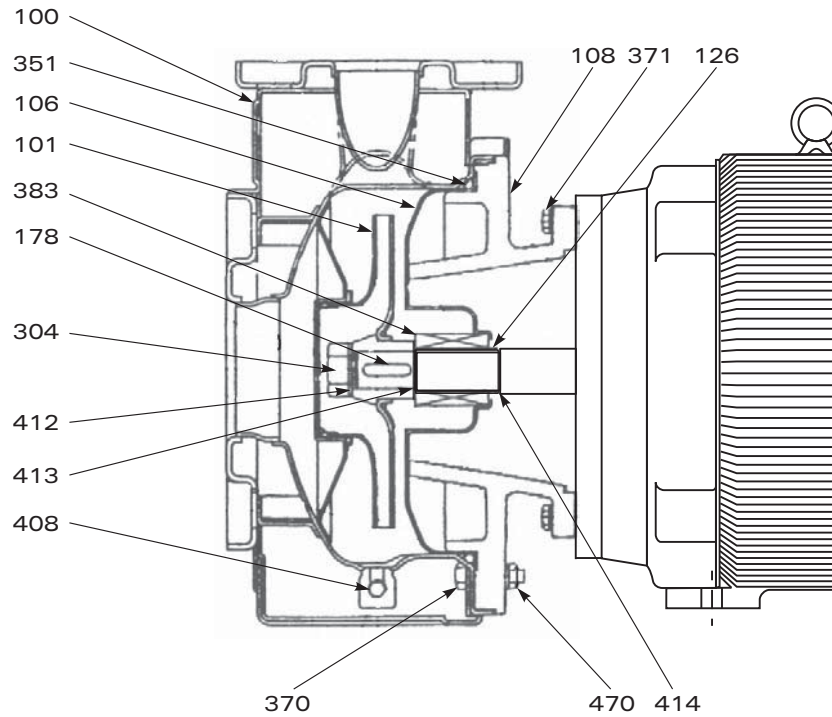

ITEM	QTY REQ'D	DESCRIPTION	MATERIAL	PART NUMBER
100	1	Casing	304 Stainless steel	E-251402208
101	1	Impeller	304 Stainless steel	E-251450880
106	1	Casing cover	304 Stainless steel	E-251402221
108	1	Adapter	C.I. (up to 184JM)	E-240080583
			C.I. (213JM and up)	E-240080584
126	1	Shaft sleeve	304 Stainless steel	E-275416013
178	1	Impeller key	Steel	E-316X316
304	1	Impeller bolt	316 SS	E-275440031
351	1	Casing o-ring	Buna	E-230X5.3B
			Viton	E-230X5.3V
370	12	Casing bolt	304 Stainless steel	E-M10X35HH
371	4	Motor bolt	Steel	E-1/2-13X1-1/2
383	1	Mechanical seal	Carbon/Ceramic/Buna	S18-2821-ABN
			Carbon/Ceramic/Viton	S18-2821-AVT
			Carbon/S.S./EPR	S18-2821-CEP
			Carbon/Carbide/Viton	S18-2821-BVT
			Carbide/Carbide/Viton	S18-2821-EVT
408	1	Casing plug	304 Stainless steel	E-363631000
412	1	Impeller gasket	Teflon	E-275476030
413	1	Sleeve gasket	Teflon	E-275476029
414	1	Sleeve gasket	Teflon	E-275476028
470	12	Casing bolt nut	304 Stainless Steel	E-M10HN



**FLO-FAB**  
Montréal, Québec

# SERIES PS Parts List

## MODEL - PSF3001

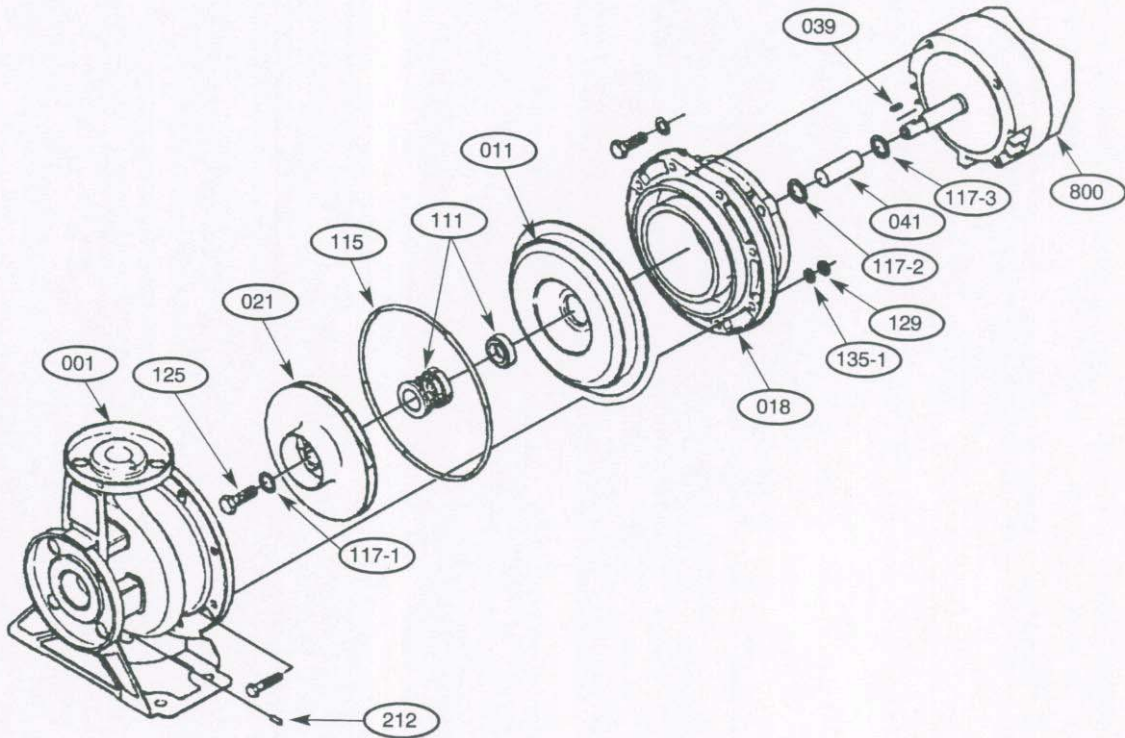

Part No.	Part Name	Material	Req'd	Part Number
001	Casing	304L Stainless	1	251421526
011	Casing cover	304L Stainless	1	251438024
018	Bracket	Cast Iron	1	240080582
021	Impeller	304L Stainless	1	240350137
039	Key	304L Stainless	1	316X1316KEY
041	Shaft sleeve	304L Stainless	1	275416013
111	Mechanical seal	Various	1	See pump price pages
115	O-Ring	Viton	1	190X5.3ORING
117-1	Gasket	Nylon	1	275476030
117-2	Gasket	Nylon	1	275476028
117-3	Gasket	Nylon	1	275476029
125	Impeller Bolt	304L Stainless	1	275440031
160	Motor support (not shown)	Steel	1 set	271472082
212	Plug	304L Stainless	1	
800	Motor	-	1	
	Suction Flange Gasket	Viton	1	364701165
	Discharge Flange Gasket	Viton	1	364701180





**FLO-FAB**  
Montréal, Québec

# SERIES PS Parts List

## MODEL - PSF3002

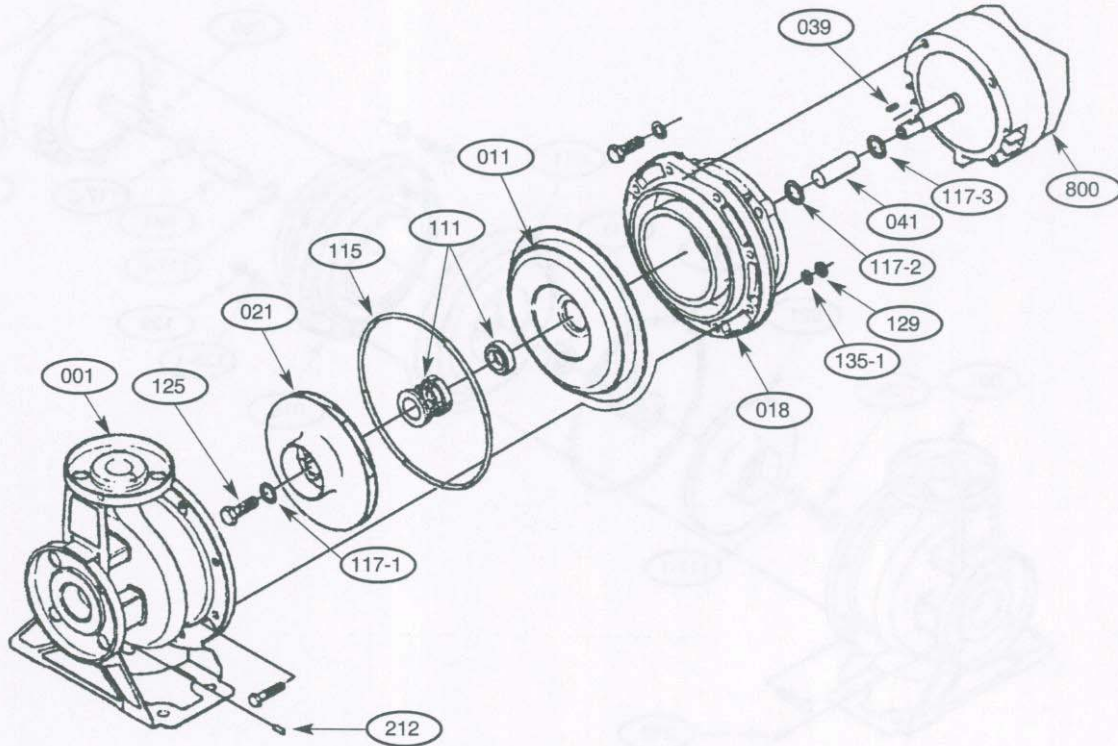

Part No.	Part Name	Material	Req'd	Part Number
001	Casing	304L Stainless	1	251421526
011	Casing cover	304L Stainless	1	251438024
018	Bracket	Cast Iron	1	240080582
021	Impeller	304L Stainless	1	240350138
039	Key	304L Stainless	1	316X1316KEY
041	Shaft sleeve	304L Stainless	1	275416013
111	Mechanical seal	Various	1	See pump price pages
115	O-Ring	Viton	1	190X5.3ORING
117-1	Gasket	Nylon	1	275476030
117-2	Gasket	Nylon	1	275476028
117-3	Gasket	Nylon	1	275476029
125	Impeller Bolt	304L Stainless	1	275440031
160	Motor support (not shown)	Steel	1 set	271472082
212	Plug	304L Stainless	1	
800	Motor	-	1	
	Suction Flange Gasket	Viton	1	364701165
	Discharge Flange Gasket	Viton	1	364701180



**FLO-FAB**  
Montréal, Québec

# SERIES PS Parts List

## MODEL - PSF3003

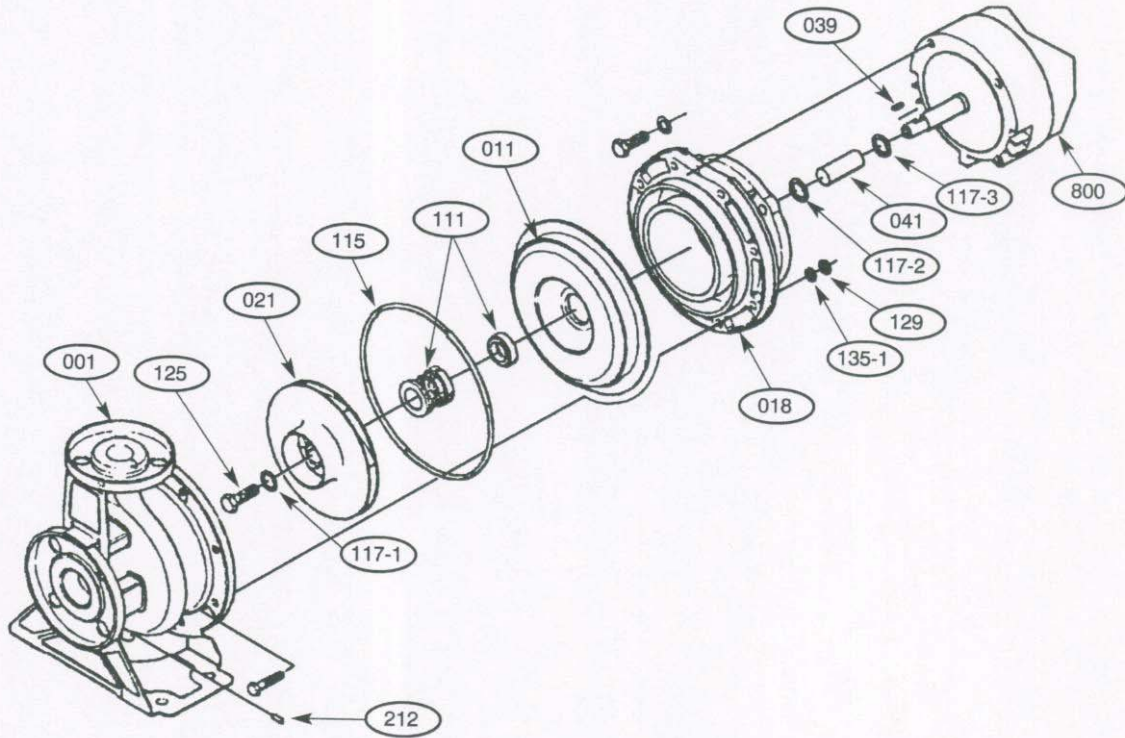

Part No.	Part Name	Material	Req'd	Part Number
001	Casing	304L Stainless	1	251421527
011	Casing cover	304L Stainless	1	251438026
018	Bracket	Cast Iron	1	240080584
021	Impeller	304L Stainless	1	240350139
039	Key	304L Stainless	1	316X1316KEY
041	Shaft sleeve	304L Stainless	1	275416013
111	Mechanical seal	Various	1	See pump price pages
115	O-Ring	Viton	1	230X5.3ORING
117-1	Gasket	Nylon	1	275476030
117-2	Gasket	Nylon	1	275476028
117-3	Gasket	Nylon	1	275476029
125	Impeller Bolt	304L Stainless	1	275440031
160	Motor support (not shown)	Steel	1 set	271472082
212	Plug	304L Stainless	1	
800	Motor	-	1	
	Suction Flange Gasket	Viton	1	364701165
	Discharge Flange Gasket	Viton	1	364701180





**FLO-FAB**  
Montréal, Québec

# SERIES PS Parts List

## MODEL - PSF3004

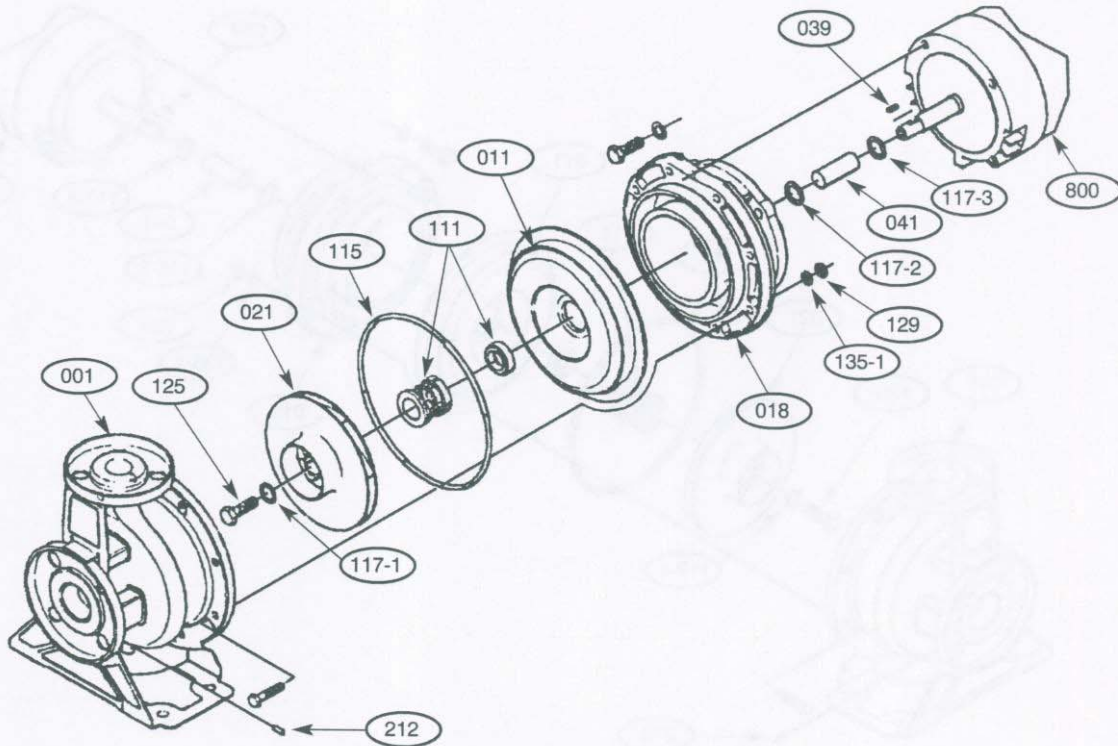

Part No.	Part Name	Material	Req'd	Part Number
001	Casing	304L Stainless	1	251421527
011	Casing cover	304L Stainless	1	251438026
018	Bracket	Cast Iron	1	240080584
021	Impeller	304L Stainless	1	240350140
039	Key	304L Stainless	1	316X1316KEY
041	Shaft sleeve	304L Stainless	1	275416013
111	Mechanical seal	Various	1	See pump price pages
115	O-Ring	Viton	1	230X5.3ORING
117-1	Gasket	Nylon	1	275476030
117-2	Gasket	Nylon	1	275476028
117-3	Gasket	Nylon	1	275476029
125	Impeller Bolt	304L Stainless	1	275440031
160	Motor support (not shown)	Steel	1 set	271472082
212	Plug	304L Stainless	1	
800	Motor	-	1	
	Suction Flange Gasket	Viton	1	364701165
	Discharge Flange Gasket	Viton	1	364701180





**FLO-FAB**  
Montréal, Québec

# SERIES PS Parts List

## MODEL - PSF3005

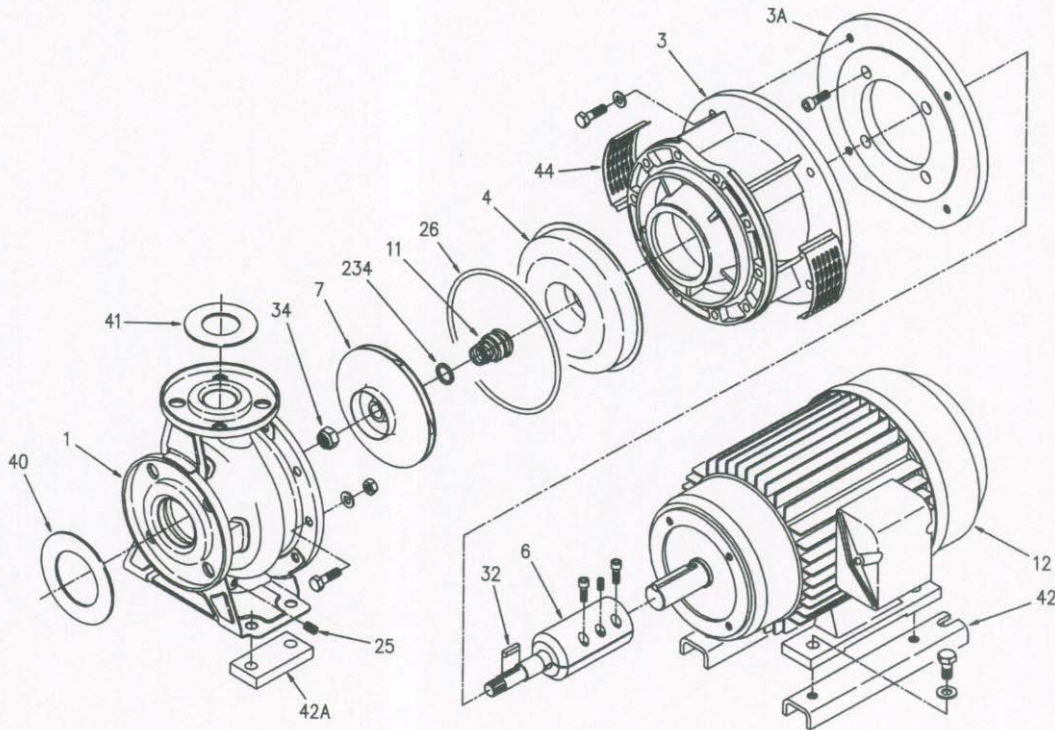

Part No.	Part Name	Material	Req'd	Part Number
001	Casing	304L Stainless	1	251421527
003	Motor Bracket	Cast Iron	1	240080603
003A	Motor Adapter	Cast Iron	1	241410133
004	Casing Cover	304L Stainless	1	251438039
006	Coupling	Steel/Stainless	1	375449005
007	Impeller	304L Stainless	1	240350141
111	Mechanical Seal	Various	1	See pump price pages
026	O-ring	Viton	1	230X5.3ORING
032	Key	304L Stainless	1	516X516KEY
034	Impeller Nut	Stainless/Nylon	1	7/8-14LOCKNUT
040	Suction Flange Gasket	EPDM	1	364701180
041	Discharge Flange Gasket	EPDM	1	364701165
042	Motor Support	Steel	2	271472167
044	Coupling Guard	Stainless	2	271473017
234	Lip Seal	304L Stainless	1	275476039





**FLO-FAB**  
Montréal, Québec

# SERIES PS Parts List

## MODEL - PSF3006

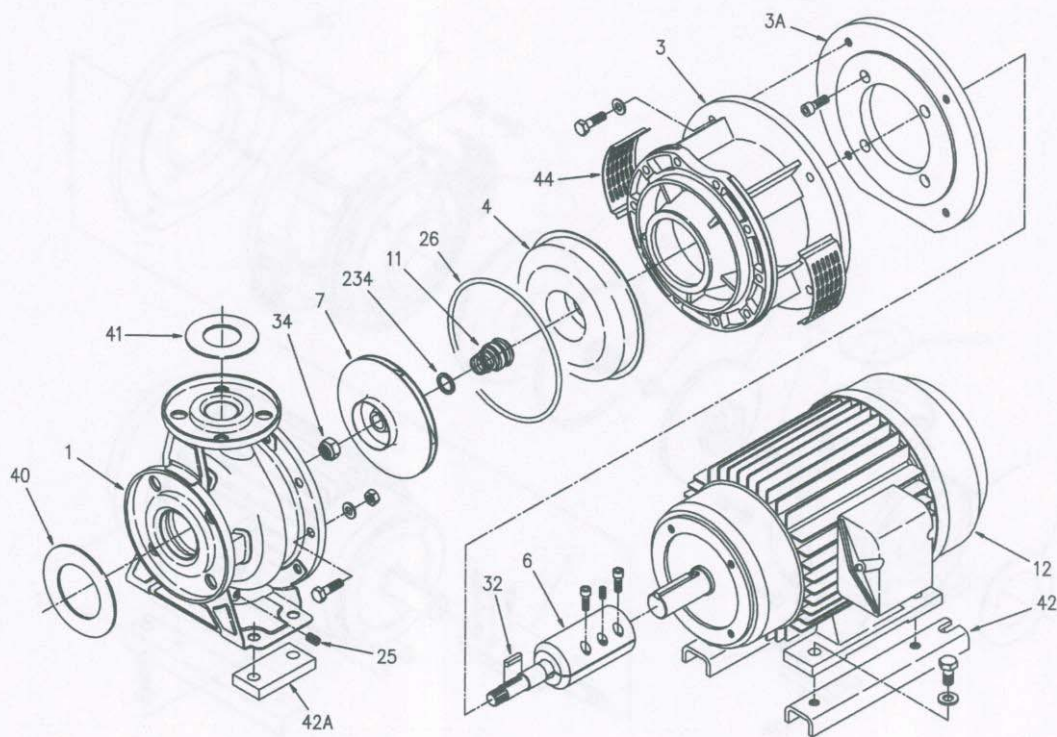

Part No.	Part Name	Material	Req'd	Part Number
001	Casing	304L Stainless	1	251421527
003	Motor Bracket	Cast Iron	1	240080603
003A	Motor Adapter	Cast Iron	1	241410134
004	Casing Cover	304L Stainless	1	251438039
006	Coupling	Steel/Stainless	1	375449005
007	Impeller	304L Stainless	1	240350142
111	Mechanical Seal	Various	1	See pump price pages
026	O-ring	Viton	1	230X5.3ORING
032	Key	304L Stainless	1	516X516KEY
034	Impeller Nut	Stainless/Nylon	1	7/8-14LOCKNUT
040	Suction Flange Gasket	EPDM	1	364701180
041	Discharge Flange Gasket	EPDM	1	364701165
042A	Casing Support	Steel	2	271472170
044	Coupling Guard	Stainless	2	271473017
234	Lip Seal	304L Stainless	1	275476039





**FLO-FAB**  
Montréal, Québec

# SERIES PS Parts List

## MODEL - PSF3007

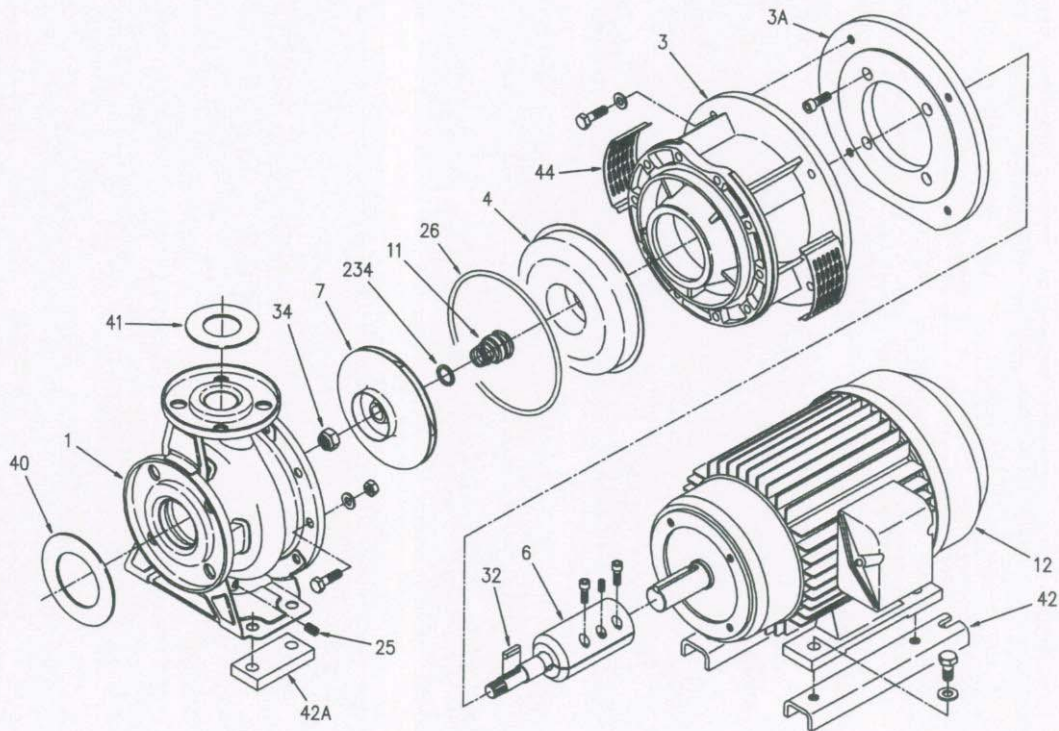

Part No.	Part Name	Material	Req'd	Part Number
001	Casing	304L Stainless	1	251421528
003	Motor Bracket	Cast Iron	1	240080603
003A	Motor Adapter	Cast Iron	1	241410133
004	Casing Cover	304L Stainless	1	251438039
006	Coupling	Steel/Stainless	1	375449005
007	Impeller	304L Stainless	1	240350143
111	Mechanical Seal	Various	1	See pump price pages
026	O-ring	Viton	1	230X5.3ORING
032	Key	304L Stainless	1	516X516KEY
034	Impeller Nut	Stainless/Nylon	1	7/8-14LOCKNUT
040	Suction Flange Gasket	EPDM	1	364701180
041	Discharge Flange Gasket	EPDM	1	364701165
042	Motor Support	Steel	2	271472169
044	Coupling Guard	Stainless	2	271473017
234	Lip Seal	304L Stainless	1	275476039





**FLO-FAB**  
Montréal, Québec

# SERIES PS Parts List

## MODEL - PSF3008

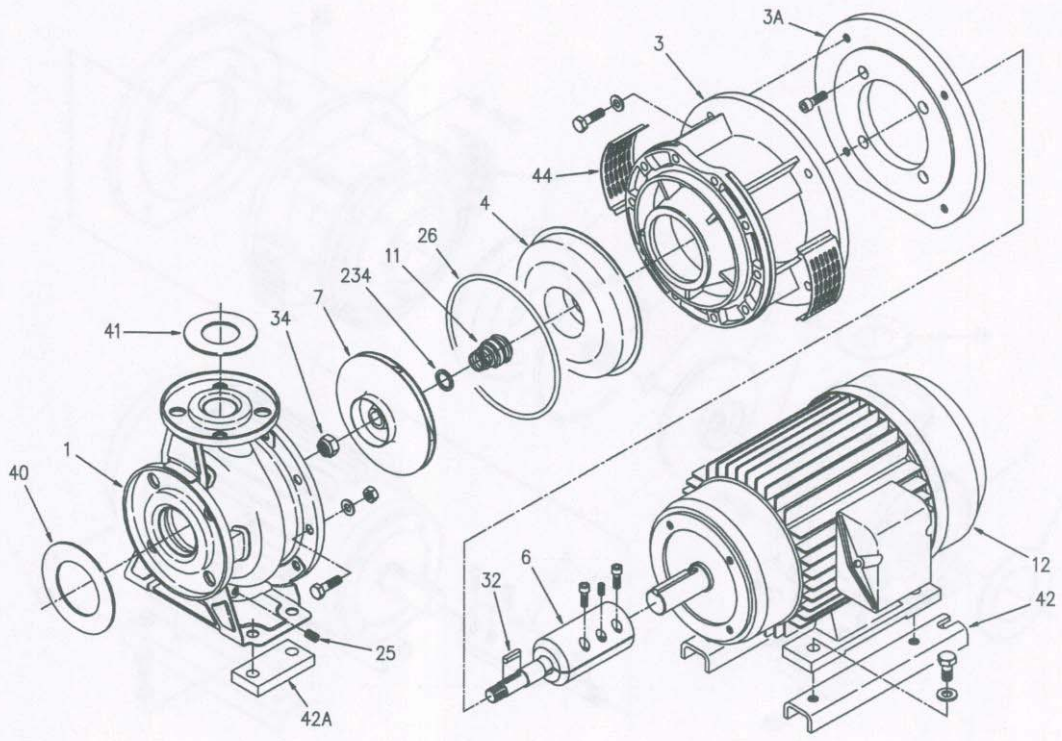

Part No.	Part Name	Material	Req'd	Part Number
001	Casing	304L Stainless	1	251421528
003	Motor Bracket	Cast Iron	1	240080603
003A	Motor Adapter	Cast Iron	1	241410134
004	Casing Cover	304L Stainless	1	251438039
006	Coupling	Steel/Stainless	1	375449005
007	Impeller	304L Stainless	1	240350144
111	Mechanical Seal	Various	1	See pump price pages
026	O-ring	Viton	1	230X5.3ORING
032	Key	304L Stainless	1	516X516KEY
034	Impeller Nut	Stainless/Nylon	1	7/8-14LOCKNUT
040	Suction Flange Gasket	EPDM	1	364701180
041	Discharge Flange Gasket	EPDM	1	364701165
042	Motor Support	Steel	2	271472168
044	Coupling Guard	Stainless	2	271473017
234	Lip Seal	304L Stainless	1	275476039





**FLO-FAB**  
Montréal, Québec

# SERIES PS Parts List

## MODEL - PSF3009

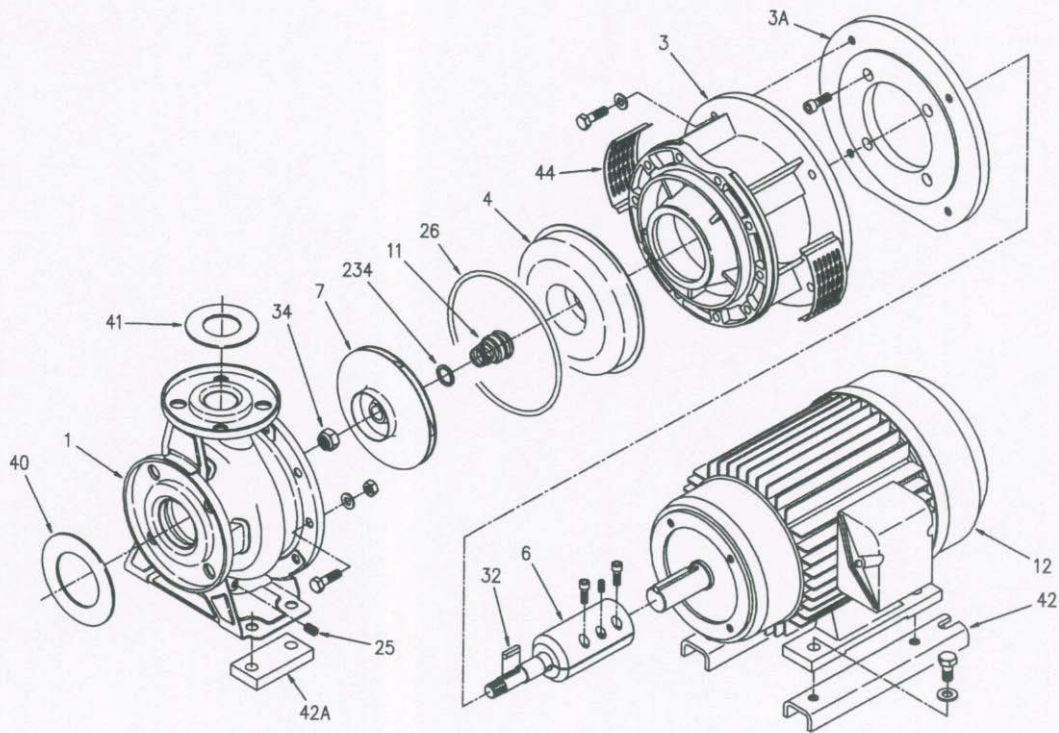

Part No.	Part Name	Material	Req'd	Part Number
001	Casing	304L Stainless	1	251421528
003	Motor Bracket	Cast Iron	1	240080603
003A	Motor Adapter	Cast Iron	1	241410134
004	Casing Cover	304L Stainless	1	251438039
006	Coupling	Steel/Stainless	1	375449005
007	Impeller	304L Stainless	1	240350145
111	Mechanical Seal	Various	1	See pump price pages
026	O-ring	Viton	1	230X5.3ORING
032	Key	304L Stainless	1	516X516KEY
034	Impeller Nut	Stainless/Nylon	1	7/8-14LOCKNUT
040	Suction Flange Gasket	EPDM	1	364701180
041	Discharge Flange Gasket	EPDM	1	364701165
042	Motor Support	Steel	2	271472168
044	Coupling Guard	Stainless	2	271473017
234	Lip Seal	304L Stainless	1	275476039



# SERIES PS - DIMENSIONAL OUTLINE

## MODEL - PSF701

CUSTOMER - \_\_\_\_\_  
 CUSTOMER REF. - \_\_\_\_\_ OUR REF. - \_\_\_\_\_  
 HP - \_\_\_\_\_ RPM - \_\_\_\_\_ VOLTAGE - \_\_\_\_\_ ENCL. - \_\_\_\_\_

CERTIFIED - \_\_\_\_\_ DATE - \_\_\_\_\_

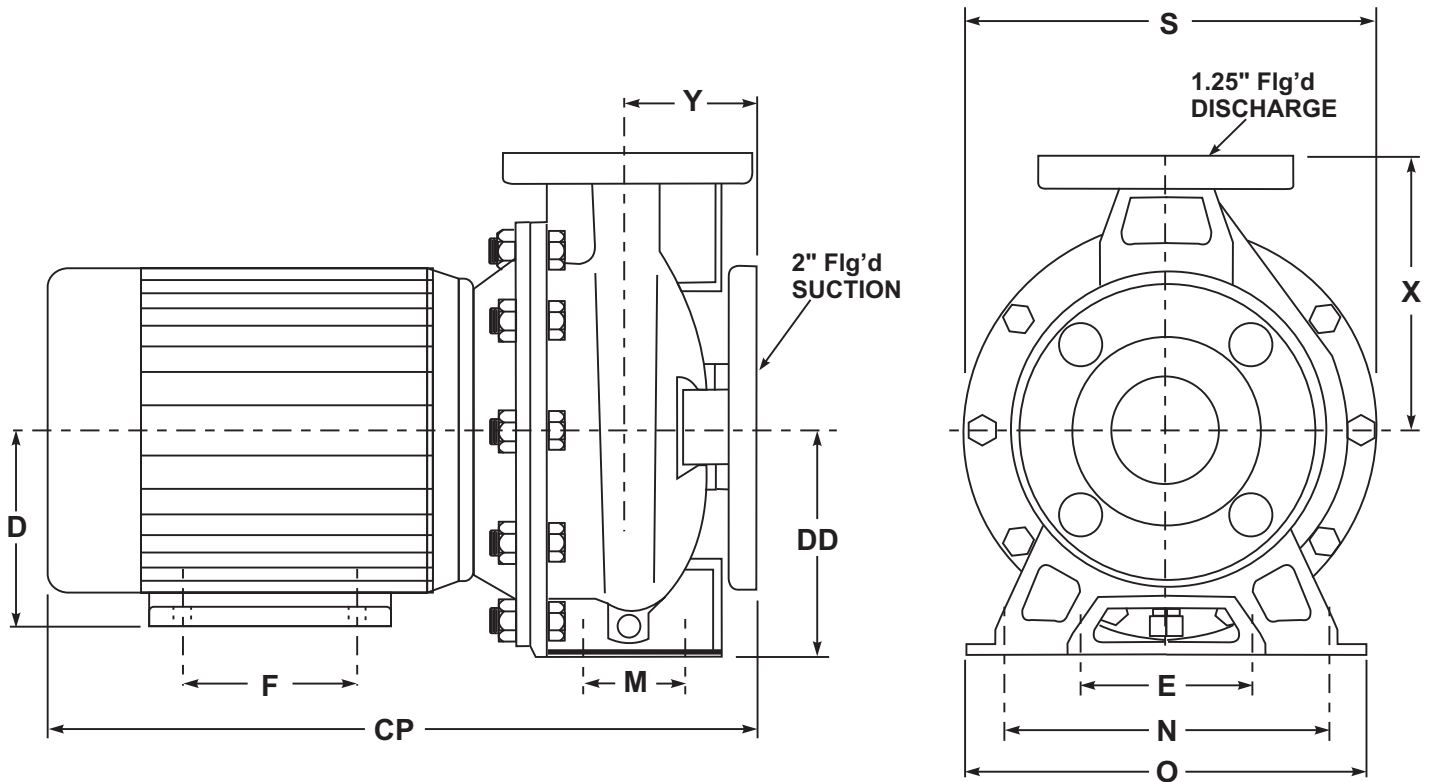

MOTOR FRAME	DIMENSIONS											WEIGHT (lbs)	
	CP*	F	E**	D	DD	M	N	O	S	X	Y	PUMP	MOTOR
143JM	16.75	4.0	5.5	3.50	4.44	2.75	5.5	7.5	8.38	5.5	3.12	20	44
145JM	17.75	5.0	5.5	3.50	4.44	2.75	5.5	7.5	8.38	5.5	3.12	20	44
182JM	18.50	4.5	7.5	4.50	4.44	2.75	5.5	7.5	8.38	5.5	3.12	20	90
184JM	19.50	5.5	7.5	4.50	4.44	2.75	5.5	7.5	8.38	5.5	3.12	20	110
213JM	21.25	5.5	8.5	5.25	4.44	2.75	5.5	7.5	8.38	5.5	3.12	20	120
215JM	22.75	7.0	8.5	5.25	4.44	2.75	5.5	7.5	8.38	5.5	3.12	20	160

NOTES - Not for construction purposes unless certified above.  
 - All dimensions in inches.  
 - Some dimensions may vary +/- 0.25 inches.  
 - \* Approximate only.  
 - \*\* Motor mount hole spacing.





# SERIES PS - DIMENSIONAL OUTLINE

## MODEL - PSF702

CUSTOMER - \_\_\_\_\_  
 CUSTOMER REF. - \_\_\_\_\_ OUR REF. - \_\_\_\_\_  
 HP - \_\_\_\_\_ RPM - \_\_\_\_\_ VOLTAGE - \_\_\_\_\_ ENCL. - \_\_\_\_\_

CERTIFIED - \_\_\_\_\_ DATE - \_\_\_\_\_

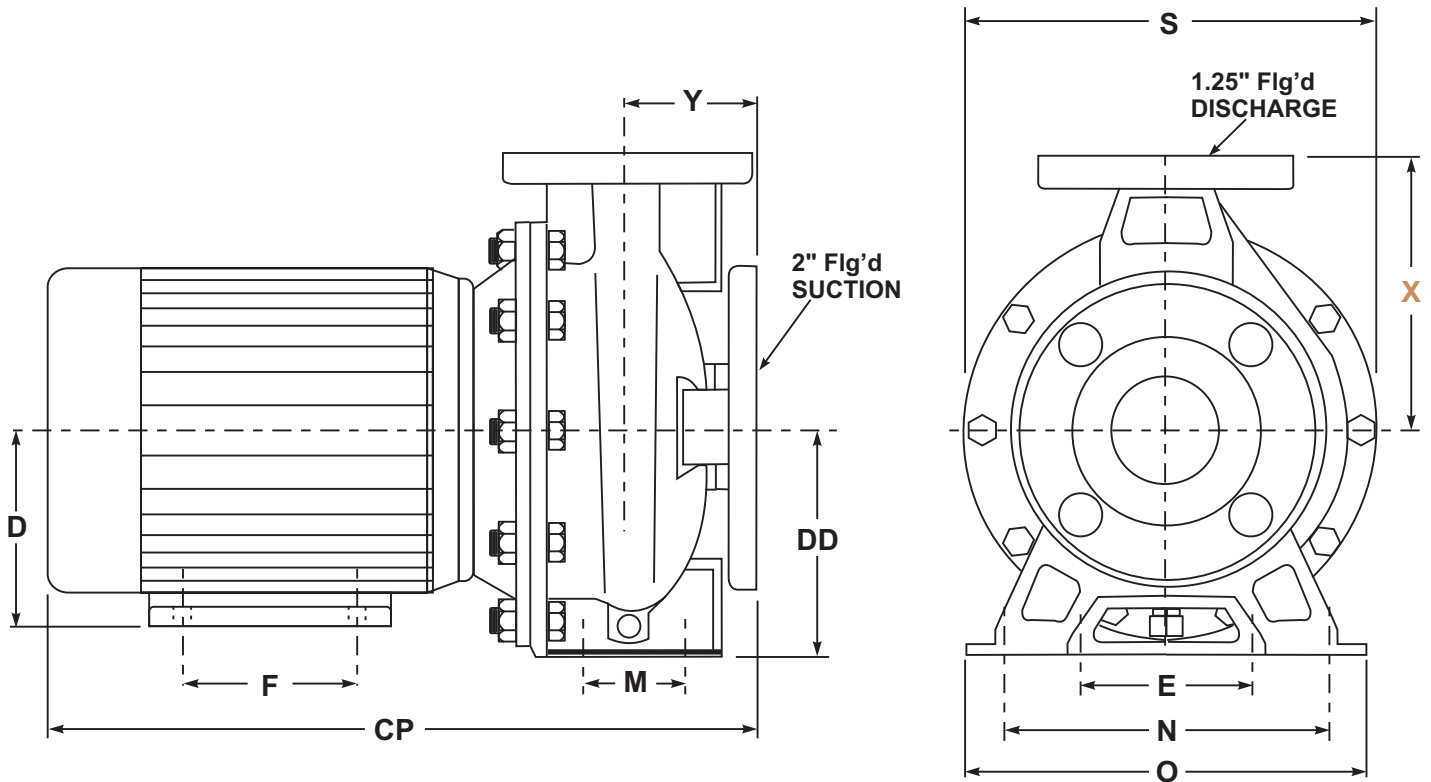

MOTOR FRAME	DIMENSIONS											WEIGHT (lbs)	
	CP*	F	E**	D	DD	M	N	O	S	X	Y	PUMP	MOTOR
143JM	16.75	4.0	5.5	3.50	5.19	2.75	7.5	9.44	10	6.31	3.12	20	44
145JM	17.75	5.0	5.5	3.50	5.19	2.75	7.5	9.44	10	6.31	3.12	20	44
182JM	18.50	4.5	7.5	4.50	5.19	2.75	7.5	9.44	10	6.31	3.12	20	90
184JM	19.50	5.5	7.5	4.50	5.19	2.75	7.5	9.44	10	6.31	3.12	20	110
213JM	21.25	5.5	8.5	5.25	5.19	2.75	7.5	9.44	10	6.31	3.12	20	120
215JM	22.75	7.0	8.5	5.25	5.19	2.75	7.5	9.44	10	6.31	3.12	20	160

NOTES - Not for construction purposes unless certified above.  
 - All dimensions in inches.  
 - Some dimensions may vary +/- 0.25 inches.  
 - \* Approximate only.  
 - \*\* Motor mount hole spacing.



# SERIES PS - DIMENSIONAL OUTLINE

## MODEL - PSF703

CUSTOMER - \_\_\_\_\_  
 CUSTOMER REF. - \_\_\_\_\_ OUR REF. - \_\_\_\_\_  
 HP - \_\_\_\_\_ RPM - \_\_\_\_\_ VOLTAGE - \_\_\_\_\_ ENCL. - \_\_\_\_\_

CERTIFIED - \_\_\_\_\_ DATE - \_\_\_\_\_

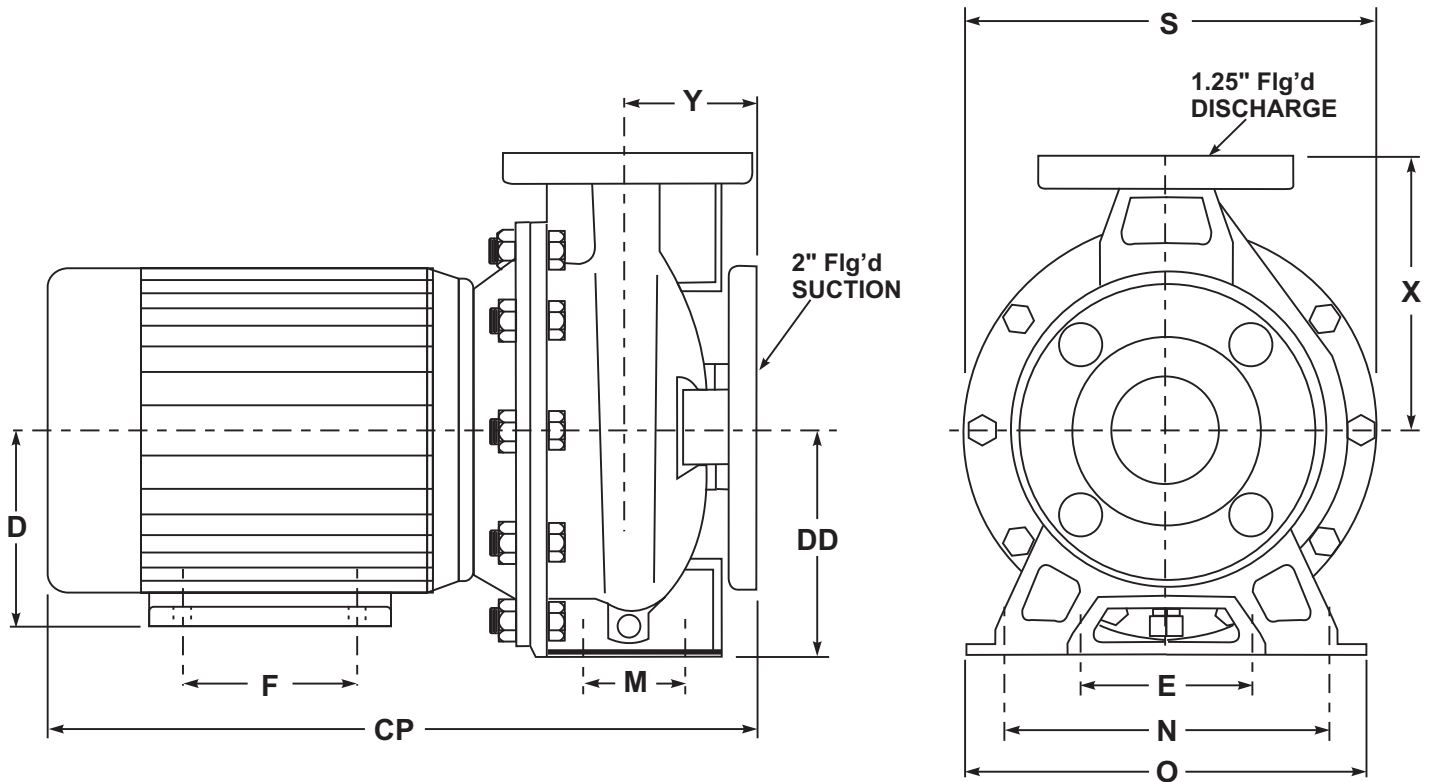

MOTOR FRAME	DIMENSIONS											WEIGHT (lbs)	
	CP*	F	E**	D	DD	M	N	O	S	X	Y	PUMP	MOTOR
143JM	16.75	4.0	5.5	3.50	5.19	2.75	7.5	9.44	10	6.31	3.12	20	44
145JM	17.75	5.0	5.5	3.50	5.19	2.75	7.5	9.44	10	6.31	3.12	20	44
182JM	18.50	4.5	7.5	4.50	5.19	2.75	7.5	9.44	10	6.31	3.12	20	90
184JM	19.50	5.5	7.5	4.50	5.19	2.75	7.5	9.44	10	6.31	3.12	20	110
213JM	21.25	5.5	8.5	5.25	5.19	2.75	7.5	9.44	10	6.31	3.12	20	120
215JM	22.75	7.0	8.5	5.25	5.19	2.75	7.5	9.44	10	6.31	3.12	20	160

NOTES - Not for construction purposes unless certified above.  
 - All dimensions in inches.  
 - Some dimensions may vary +/- 0.25 inches.  
 - \* Approximate only.  
 - \*\* Motor mount hole spacing.



# SERIES PS - DIMENSIONAL OUTLINE

## MODEL - PSF704

CUSTOMER - \_\_\_\_\_  
 CUSTOMER REF. - \_\_\_\_\_ OUR REF. - \_\_\_\_\_  
 HP - \_\_\_\_\_ RPM - \_\_\_\_\_ VOLTAGE - \_\_\_\_\_ ENCL. - \_\_\_\_\_

CERTIFIED - \_\_\_\_\_ DATE - \_\_\_\_\_

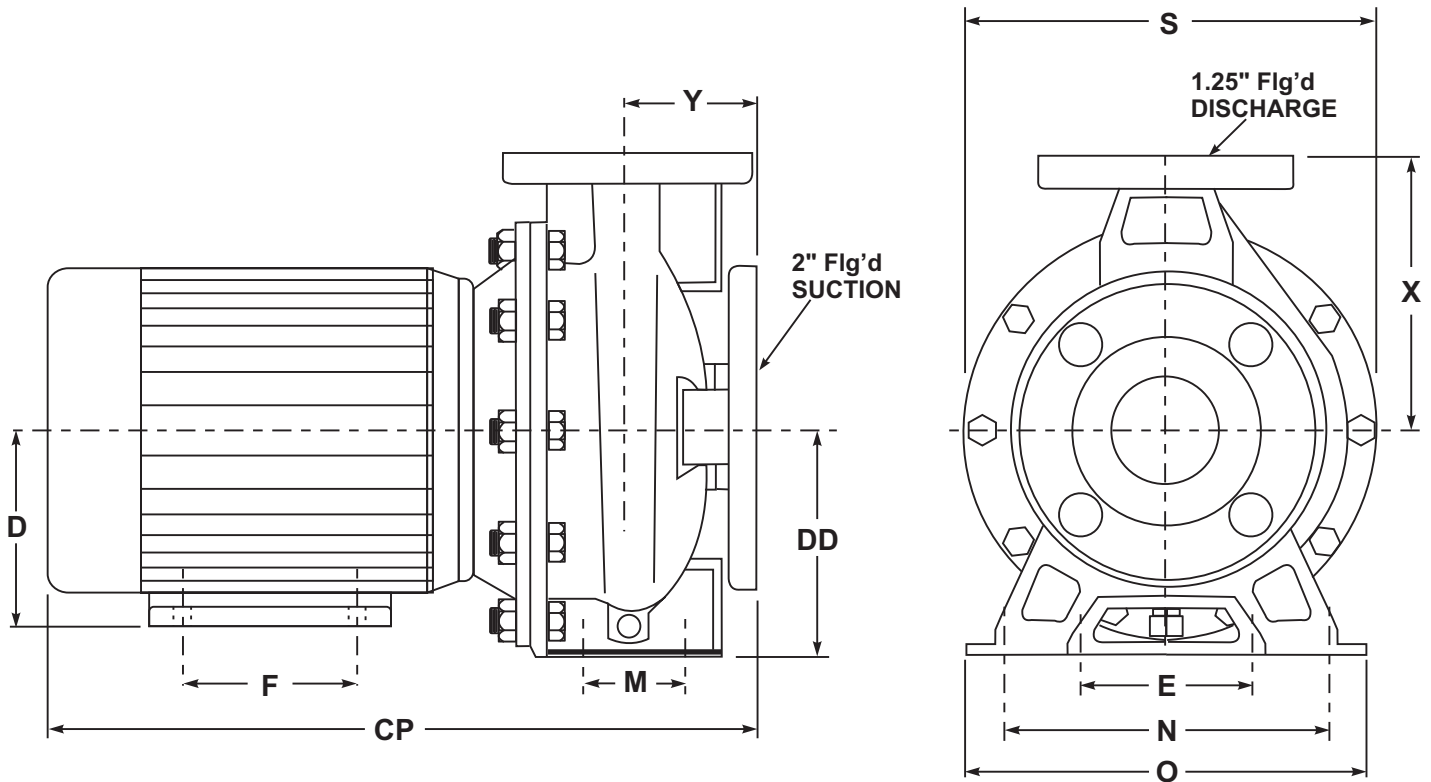

MOTOR FRAME	DIMENSIONS											WEIGHT (lbs)	
	CP*	F	E**	D	DD	M	N	O	S	X	Y	PUMP	MOTOR
143JM	19.00	4.0	5.5	3.50	6.31	2.75	7.5	9.44	11.56	7.06	3.12	20	44
145JM	20.00	5.0	5.5	3.50	6.31	2.75	7.5	9.44	11.56	7.06	3.12	20	44
182JM	21.75	4.5	7.5	4.50	6.31	2.75	7.5	9.44	11.56	7.06	3.12	20	90
184JM	22.75	5.5	7.5	4.50	6.31	2.75	7.5	9.44	11.56	7.06	3.12	20	110
213JM	24.50	5.5	8.5	5.25	6.31	2.75	7.5	9.44	11.56	7.06	3.12	20	120
215JM	26.00	7.0	8.5	5.25	6.31	2.75	7.5	9.44	11.56	7.06	3.12	20	160

NOTES - Not for construction purposes unless certified above.  
 - All dimensions in inches.  
 - Some dimensions may vary +/- 0.25 inches.  
 - \* Approximate only.  
 - \*\* Motor mount hole spacing.



# SERIES PS - DIMENSIONAL OUTLINE

## MODEL - PSF705

CUSTOMER - \_\_\_\_\_  
 CUSTOMER REF. - \_\_\_\_\_ OUR REF. - \_\_\_\_\_  
 HP - \_\_\_\_\_ RPM - \_\_\_\_\_ VOLTAGE - \_\_\_\_\_ ENCL. - \_\_\_\_\_

CERTIFIED - \_\_\_\_\_ DATE - \_\_\_\_\_

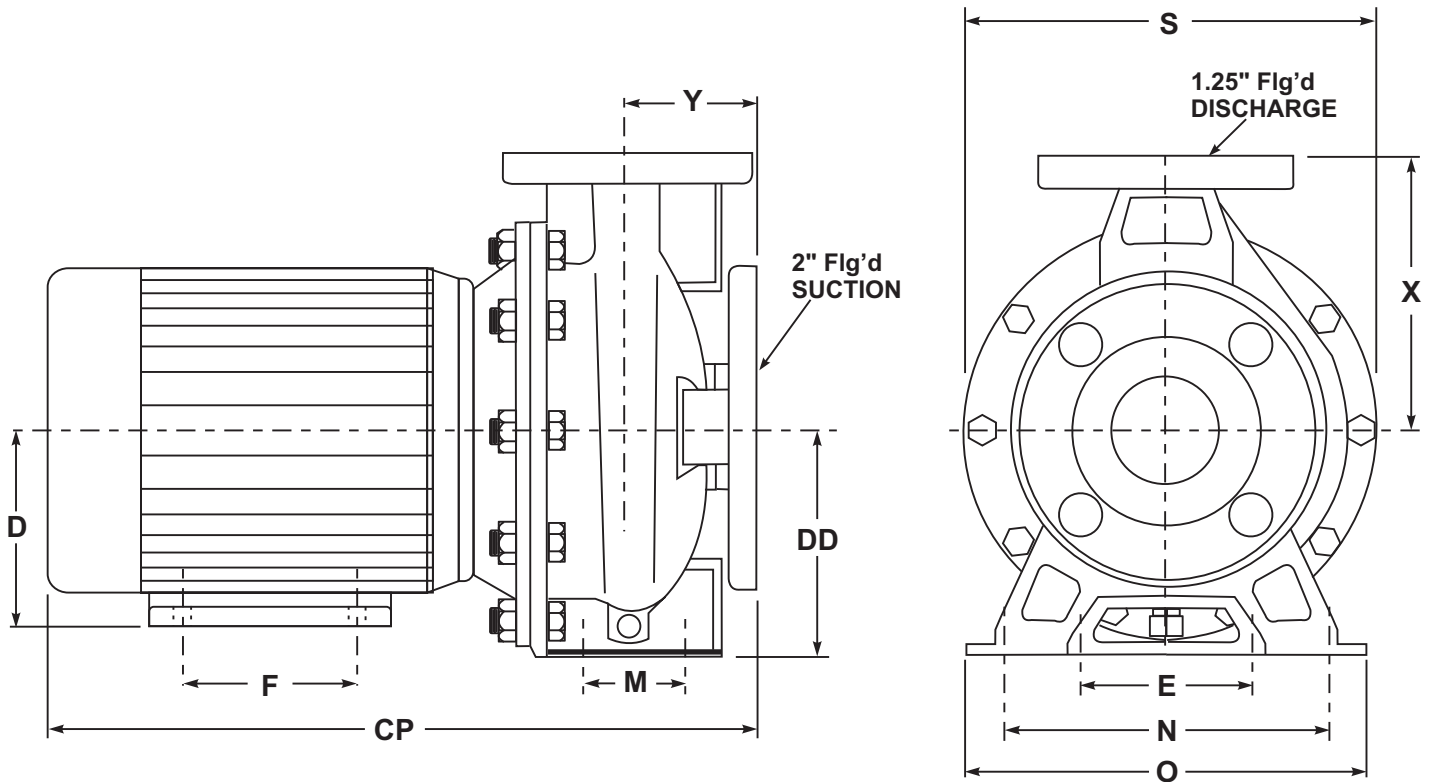

MOTOR FRAME	DIMENSIONS											WEIGHT (lbs)	
	CP*	F	E**	D	DD	M	N	O	S	X	Y	PUMP	MOTOR
143JM	19.00	4.0	5.5	3.50	6.31	2.75	7.5	9.44	11.56	7.06	3.12	20	44
145JM	20.00	5.0	5.5	3.50	6.31	2.75	7.5	9.44	11.56	7.06	3.12	20	44
182JM	21.75	4.5	7.5	4.50	6.31	2.75	7.5	9.44	11.56	7.06	3.12	20	90
184JM	22.75	5.5	7.5	4.50	6.31	2.75	7.5	9.44	11.56	7.06	3.12	20	110
213JM	24.50	5.5	8.5	5.25	6.31	2.75	7.5	9.44	11.56	7.06	3.12	20	120
215JM	26.00	7.0	8.5	5.25	6.31	2.75	7.5	9.44	11.56	7.06	3.12	20	160

NOTES - Not for construction purposes unless certified above.  
 - All dimensions in inches.  
 - Some dimensions may vary +/- 0.25 inches.  
 - \* Approximate only.  
 - \*\* Motor mount hole spacing.



# SERIES PS - DIMENSIONAL OUTLINE

## MODEL - PSF1201

CUSTOMER - \_\_\_\_\_  
 CUSTOMER REF. - \_\_\_\_\_ OUR REF. - \_\_\_\_\_  
 HP - \_\_\_\_\_ RPM - \_\_\_\_\_ VOLTAGE - \_\_\_\_\_ ENCL. - \_\_\_\_\_

CERTIFIED - \_\_\_\_\_ DATE - \_\_\_\_\_

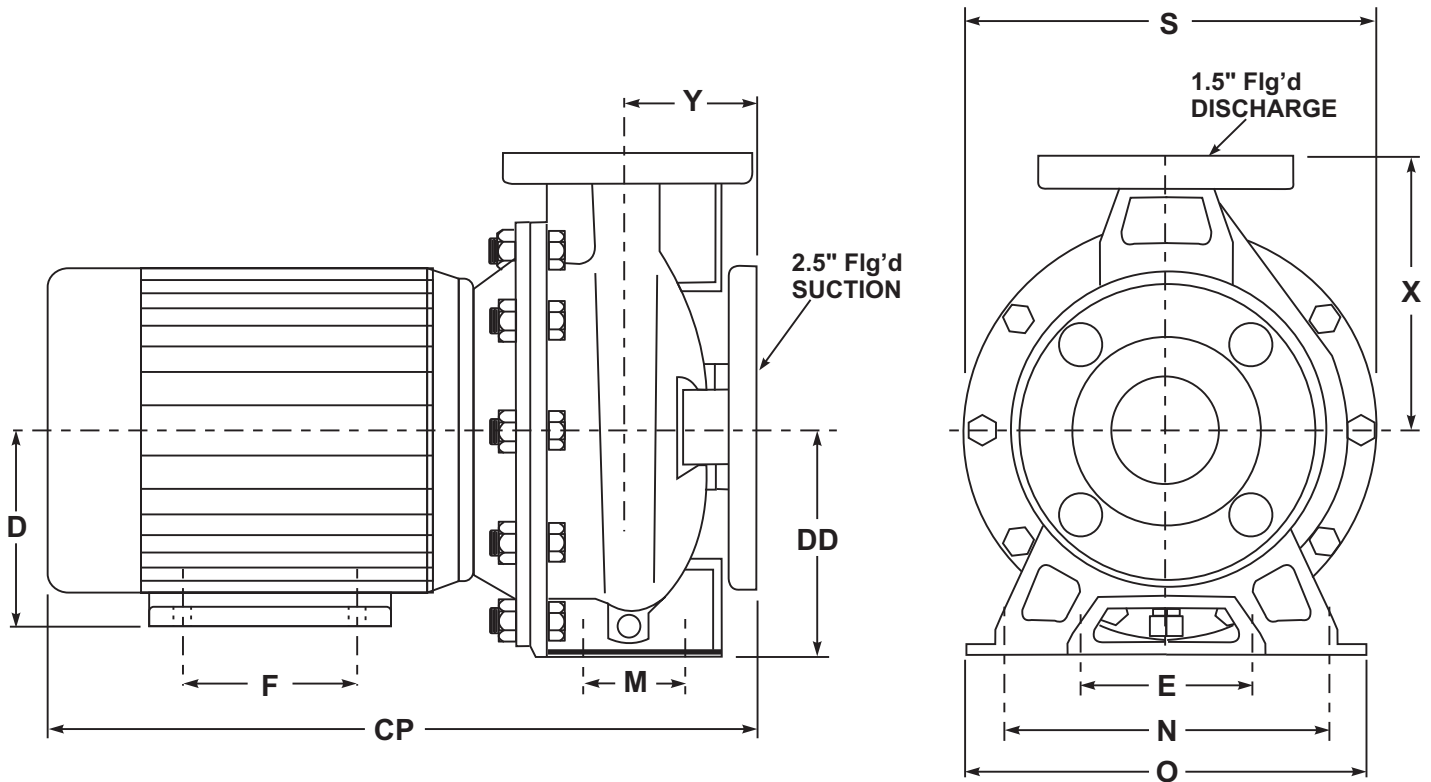

MOTOR FRAME	DIMENSIONS											WEIGHT (lbs)	
	CP*	F	E**	D	DD	M	N	O	S	X	Y	PUMP	MOTOR
143JM	16.75	4.0	5.5	3.50	4.44	2.75	6.31	8.25	8.75	5.5	3.12	21	44
145JM	17.75	5.0	5.5	3.50	4.44	2.75	6.31	8.25	8.75	5.5	3.12	21	44
182JM	18.50	4.5	7.5	4.50	4.44	2.75	6.31	8.25	8.75	5.5	3.12	21	90
184JM	19.50	5.5	7.5	4.50	4.44	2.75	6.31	8.25	8.75	5.5	3.12	21	110
213JM	21.25	5.5	8.5	5.25	4.44	2.75	6.31	8.25	8.75	5.5	3.12	21	120
215JM	22.75	7.0	8.5	5.25	4.44	2.75	6.31	8.25	8.75	5.5	3.12	21	160

NOTES - Not for construction purposes unless certified above.  
 - All dimensions in inches.  
 - Some dimensions may vary +/- 0.25 inches.  
 - \* Approximate only.  
 - \*\* Motor mount hole spacing.



**SERIES PS - DIMENSIONAL OUTLINE**  
**MODEL - PSF1202**

CUSTOMER - \_\_\_\_\_  
 CUSTOMER REF. - \_\_\_\_\_ OUR REF. - \_\_\_\_\_  
 HP - \_\_\_\_\_ RPM - \_\_\_\_\_ VOLTAGE - \_\_\_\_\_ ENCL. - \_\_\_\_\_

CERTIFIED - \_\_\_\_\_ DATE - \_\_\_\_\_

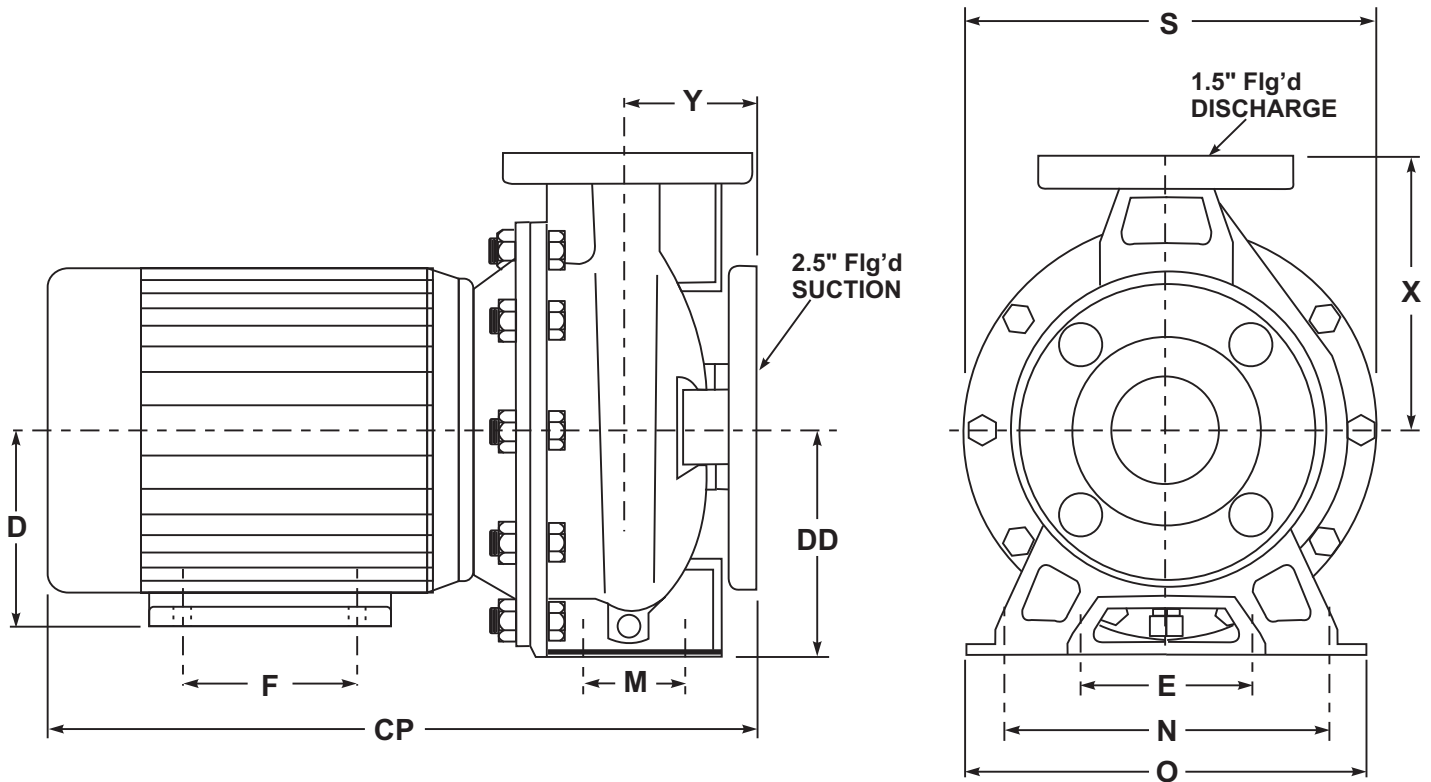

MOTOR FRAME	DIMENSIONS											WEIGHT (lbs)	
	CP*	F	E**	D	DD	M	N	O	S	X	Y	PUMP	MOTOR
143JM	16.75	4.0	5.5	3.50	4.44	2.75	6.31	8.25	8.75	5.5	3.12	21	44
145JM	17.75	5.0	5.5	3.50	4.44	2.75	6.31	8.25	8.75	5.5	3.12	21	44
182JM	18.50	4.5	7.5	4.50	4.44	2.75	6.31	8.25	8.75	5.5	3.12	21	90
184JM	19.50	5.5	7.5	4.50	4.44	2.75	6.31	8.25	8.75	5.5	3.12	21	110
213JM	21.25	5.5	8.5	5.25	4.44	2.75	6.31	8.25	8.75	5.5	3.12	21	120
215JM	22.75	7.0	8.5	5.25	4.44	2.75	6.31	8.25	8.75	5.5	3.12	21	160

NOTES - Not for construction purposes unless certified above.  
 - All dimensions in inches.  
 - Some dimensions may vary +/- 0.25 inches.  
 - \* Approximate only.  
 - \*\* Motor mount hole spacing.





**SERIES PS - DIMENSIONAL OUTLINE**  
**MODEL - PSF1203**

CUSTOMER - \_\_\_\_\_  
 CUSTOMER REF. - \_\_\_\_\_ OUR REF. - \_\_\_\_\_  
 HP - \_\_\_\_\_ RPM - \_\_\_\_\_ VOLTAGE - \_\_\_\_\_ ENCL. - \_\_\_\_\_

CERTIFIED - \_\_\_\_\_ DATE - \_\_\_\_\_

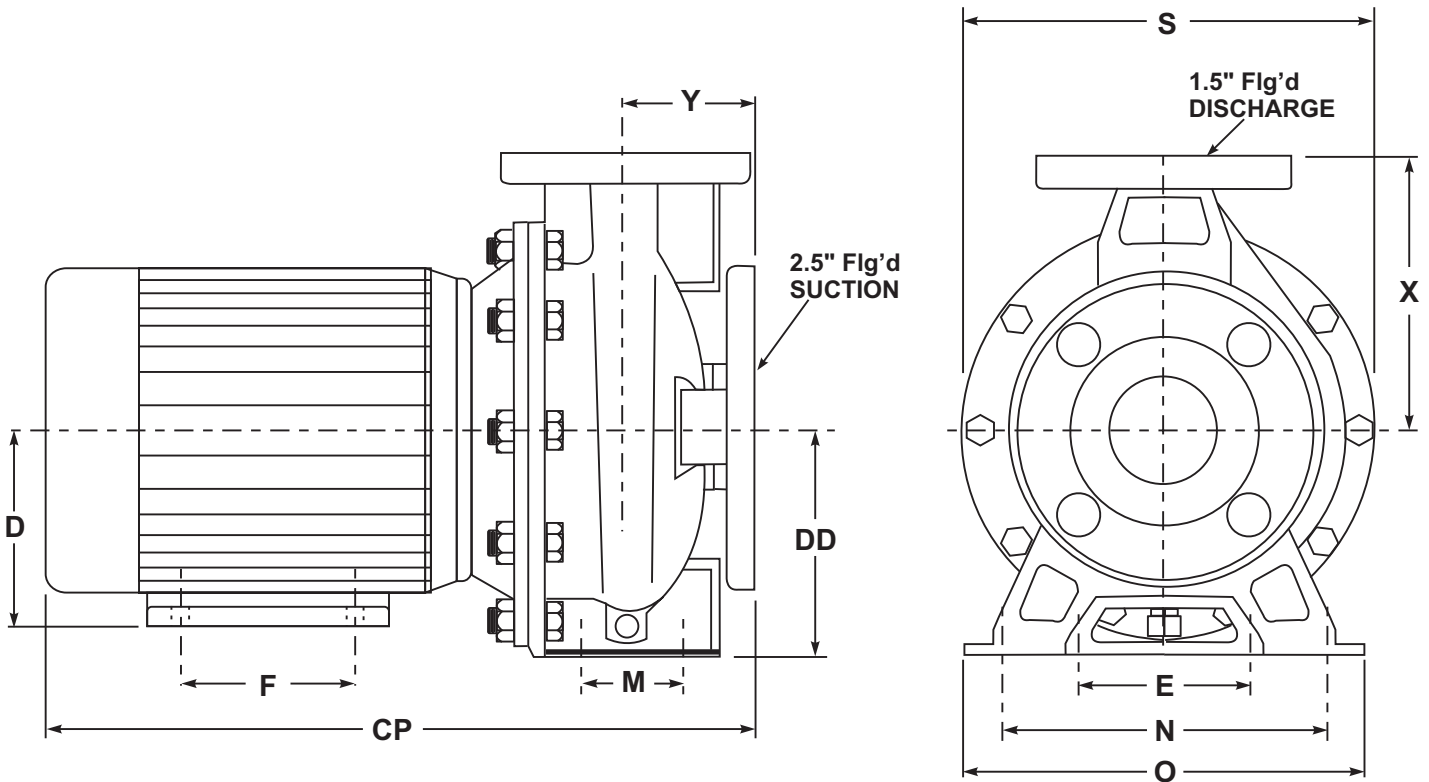

MOTOR FRAME	DIMENSIONS											WEIGHT (lbs)	
	CP*	F	E**	D	DD	M	N	O	S	X	Y	PUMP	MOTOR
143JM	16.75	4.0	5.5	3.50	5.19	2.75	7.5	9.44	10	6.31	3.12	21	44
145JM	17.75	5.0	5.5	3.50	5.19	2.75	7.5	9.44	10	6.31	3.12	21	44
182JM	18.50	4.5	7.5	4.50	5.19	2.75	7.5	9.44	10	6.31	3.12	21	90
184JM	19.50	5.5	7.5	4.50	5.19	2.75	7.5	9.44	10	6.31	3.12	21	110
213JM	21.25	5.5	8.5	5.25	5.19	2.75	7.5	9.44	10	6.31	3.12	21	120
215JM	22.75	7.0	8.5	5.25	5.19	2.75	7.5	9.44	10	6.31	3.12	21	160

NOTES - Not for construction purposes unless certified above.  
 - All dimensions in inches.  
 - Some dimensions may vary +/- 0.25 inches.  
 - \* Approximate only.  
 - \*\* Motor mount hole spacing.



# SERIES PS - DIMENSIONAL OUTLINE

## MODEL - PSF1204

CUSTOMER - \_\_\_\_\_  
 CUSTOMER REF. - \_\_\_\_\_ OUR REF. - \_\_\_\_\_  
 HP - \_\_\_\_\_ RPM - \_\_\_\_\_ VOLTAGE - \_\_\_\_\_ ENCL. - \_\_\_\_\_

CERTIFIED - \_\_\_\_\_ DATE - \_\_\_\_\_

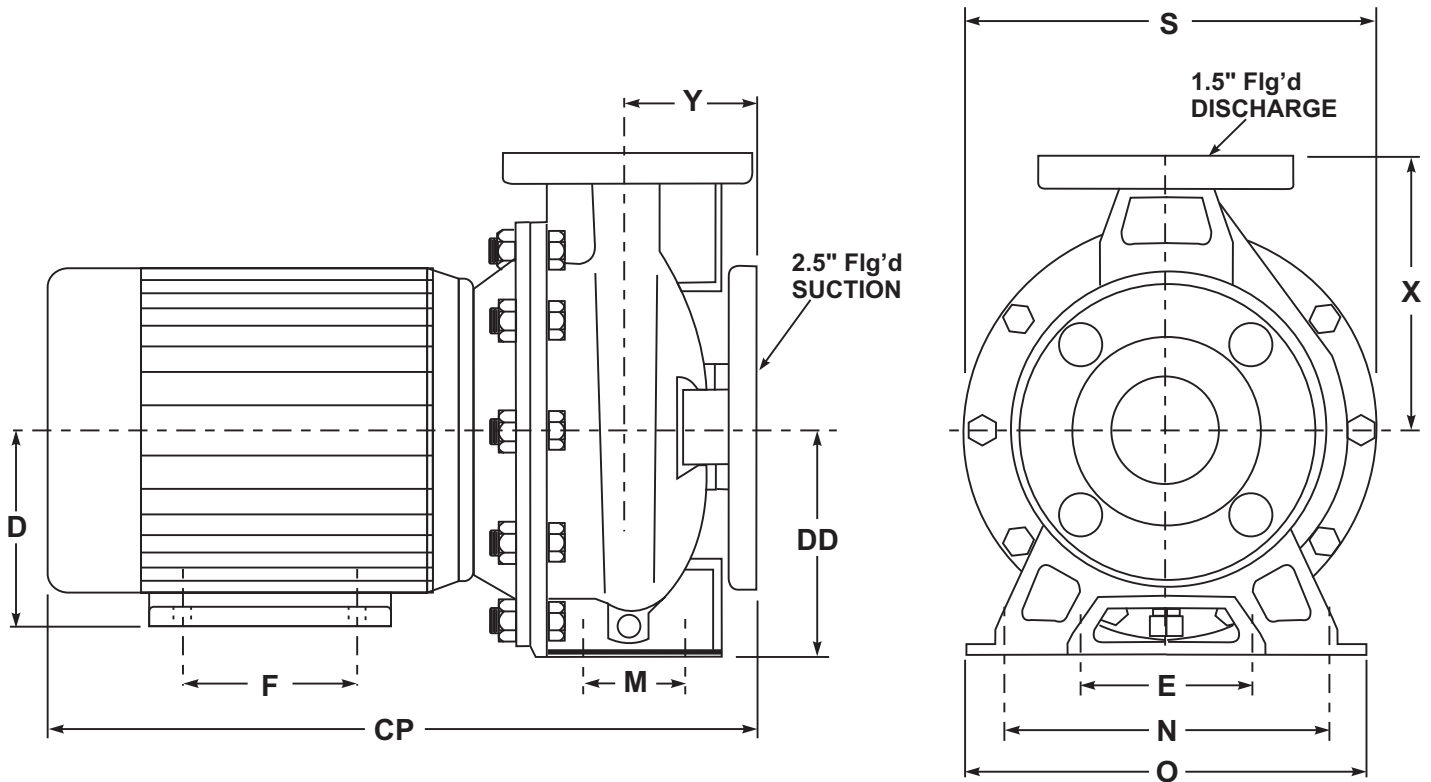

MOTOR FRAME	DIMENSIONS											WEIGHT (lbs)	
	CP*	F	E**	D	DD	M	N	O	S	X	Y	PUMP	MOTOR
143JM	16.75	4.0	5.5	3.50	5.19	2.75	7.5	9.44	10	6.31	3.12	21	44
145JM	17.75	5.0	5.5	3.50	5.19	2.75	7.5	9.44	10	6.31	3.12	21	44
182JM	18.50	4.5	7.5	4.50	5.19	2.75	7.5	9.44	10	6.31	3.12	21	90
184JM	19.50	5.5	7.5	4.50	5.19	2.75	7.5	9.44	10	6.31	3.12	21	110
213JM	21.25	5.5	8.5	5.25	5.19	2.75	7.5	9.44	10	6.31	3.12	21	120
215JM	22.75	7.0	8.5	5.25	5.19	2.75	7.5	9.44	10	6.31	3.12	21	160

NOTES - Not for construction purposes unless certified above.  
 - All dimensions in inches.  
 - Some dimensions may vary +/- 0.25 inches.  
 - \* Approximate only.  
 - \*\* Motor mount hole spacing.



**SERIES PS - DIMENSIONAL OUTLINE**  
**MODEL - PSF1205**

CUSTOMER - \_\_\_\_\_  
 CUSTOMER REF. - \_\_\_\_\_ OUR REF. - \_\_\_\_\_  
 HP - \_\_\_\_\_ RPM - \_\_\_\_\_ VOLTAGE - \_\_\_\_\_ ENCL. - \_\_\_\_\_

CERTIFIED - \_\_\_\_\_ DATE - \_\_\_\_\_

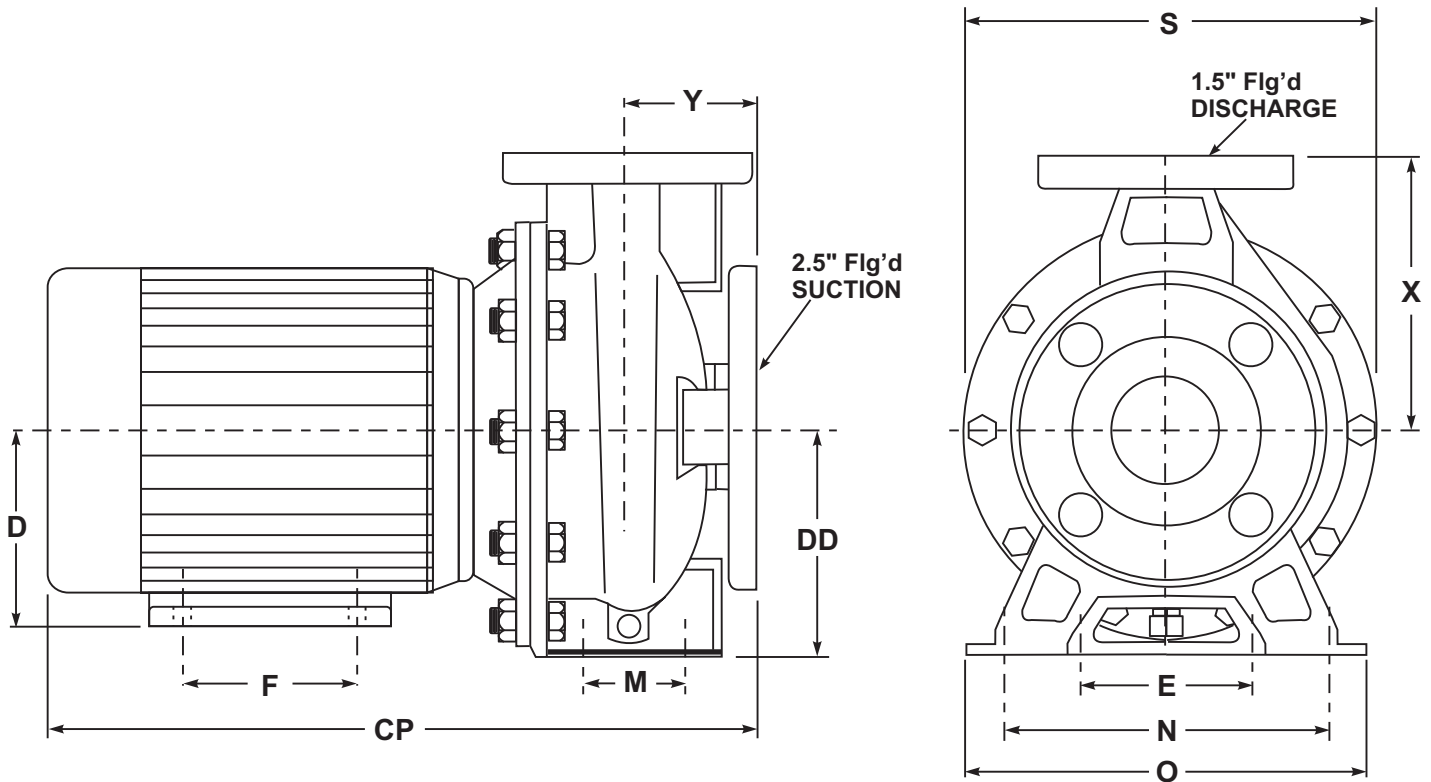

MOTOR FRAME	DIMENSIONS											WEIGHT (lbs)	
	CP*	F	E**	D	DD	M	N	O	S	X	Y	PUMP	MOTOR
143JM	17.75	4.0	5.5	3.50	6.31	2.75	8.38	10.44	11.56	7.06	3.94	21	44
145JM	18.75	5.0	5.5	3.50	6.31	2.75	8.38	10.44	11.56	7.06	3.94	21	44
182JM	19.50	4.5	7.5	4.50	6.31	2.75	8.38	10.44	11.56	7.06	3.94	21	90
184JM	20.50	5.5	7.5	4.50	6.31	2.75	8.38	10.44	11.56	7.06	3.94	21	110
213JM	22.25	5.5	8.5	5.25	6.31	2.75	8.38	10.44	11.56	7.06	3.94	21	120
215JM	23.75	7.0	8.5	5.25	6.31	2.75	8.38	10.44	11.56	7.06	3.94	21	160

NOTES - Not for construction purposes unless certified above.  
 - All dimensions in inches.  
 - Some dimensions may vary +/- 0.25 inches.  
 - \* Approximate only.  
 - \*\* Motor mount hole spacing.



# SERIES PS - DIMENSIONAL OUTLINE

## MODEL - PSF1206

CUSTOMER - \_\_\_\_\_  
 CUSTOMER REF. - \_\_\_\_\_ OUR REF. - \_\_\_\_\_  
 HP - \_\_\_\_\_ RPM - \_\_\_\_\_ VOLTAGE - \_\_\_\_\_ ENCL. - \_\_\_\_\_

CERTIFIED - \_\_\_\_\_ DATE - \_\_\_\_\_

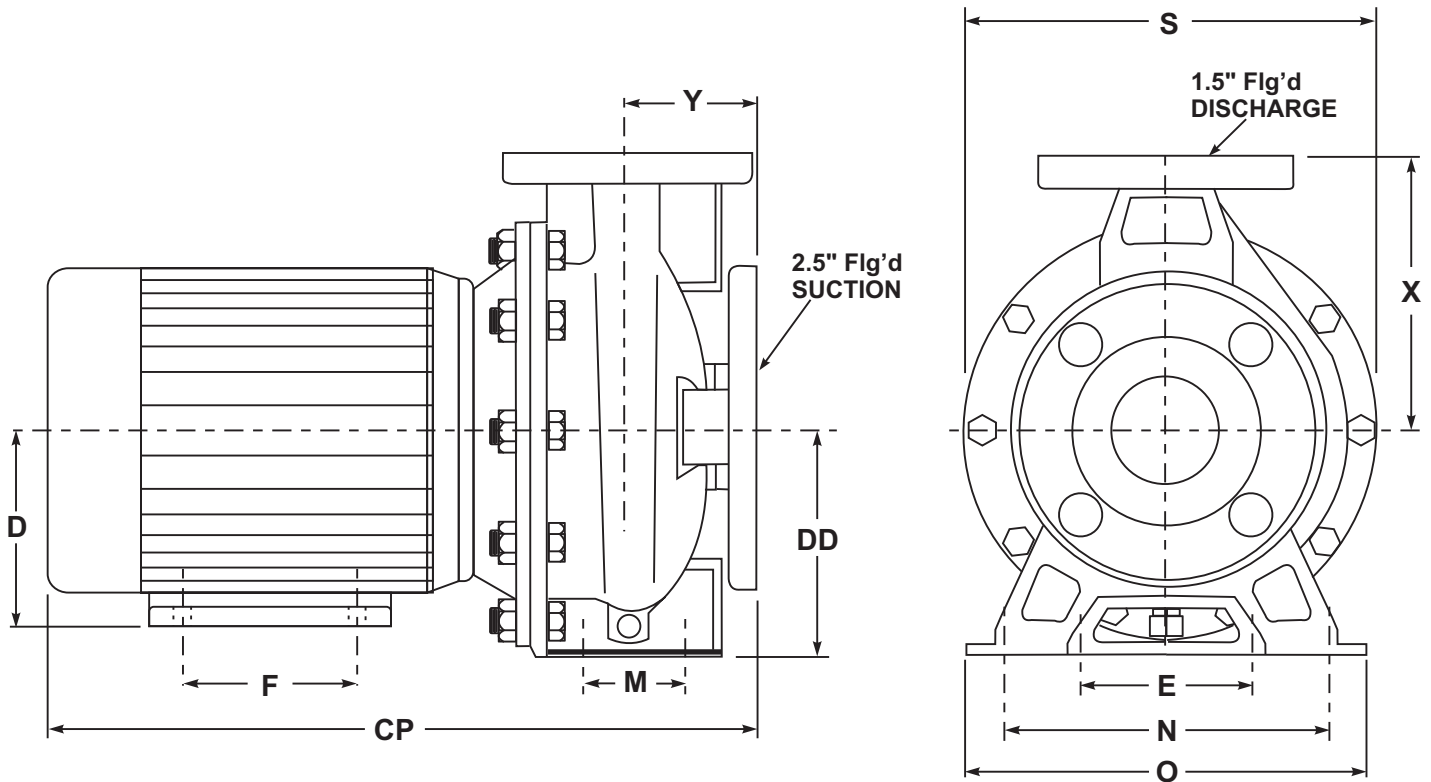

MOTOR FRAME	DIMENSIONS											WEIGHT (lbs)	
	CP*	F	E**	D	DD	M	N	O	S	X	Y	PUMP	MOTOR
143JM	17.75	4.0	5.5	3.50	6.31	2.75	8.38	10.44	11.56	7.06	3.94	21	44
145JM	18.75	5.0	5.5	3.50	6.31	2.75	8.38	10.44	11.56	7.06	3.94	21	44
182JM	19.50	4.5	7.5	4.50	6.31	2.75	8.38	10.44	11.56	7.06	3.94	21	90
184JM	20.50	5.5	7.5	4.50	6.31	2.75	8.38	10.44	11.56	7.06	3.94	21	110
213JM	22.25	5.5	8.5	5.25	6.31	2.75	8.38	10.44	11.56	7.06	3.94	21	120
215JM	23.75	7.0	8.5	5.25	6.31	2.75	8.38	10.44	11.56	7.06	3.94	21	160

NOTES - Not for construction purposes unless certified above.  
 - All dimensions in inches.  
 - Some dimensions may vary +/- 0.25 inches.  
 - \* Approximate only.  
 - \*\* Motor mount hole spacing.



# SERIES PS - DIMENSIONAL OUTLINE

## MODEL - PSF2001

CUSTOMER - \_\_\_\_\_  
 CUSTOMER REF. - \_\_\_\_\_ OUR REF. - \_\_\_\_\_  
 HP - \_\_\_\_\_ RPM - \_\_\_\_\_ VOLTAGE - \_\_\_\_\_ ENCL. - \_\_\_\_\_

CERTIFIED - \_\_\_\_\_ DATE - \_\_\_\_\_

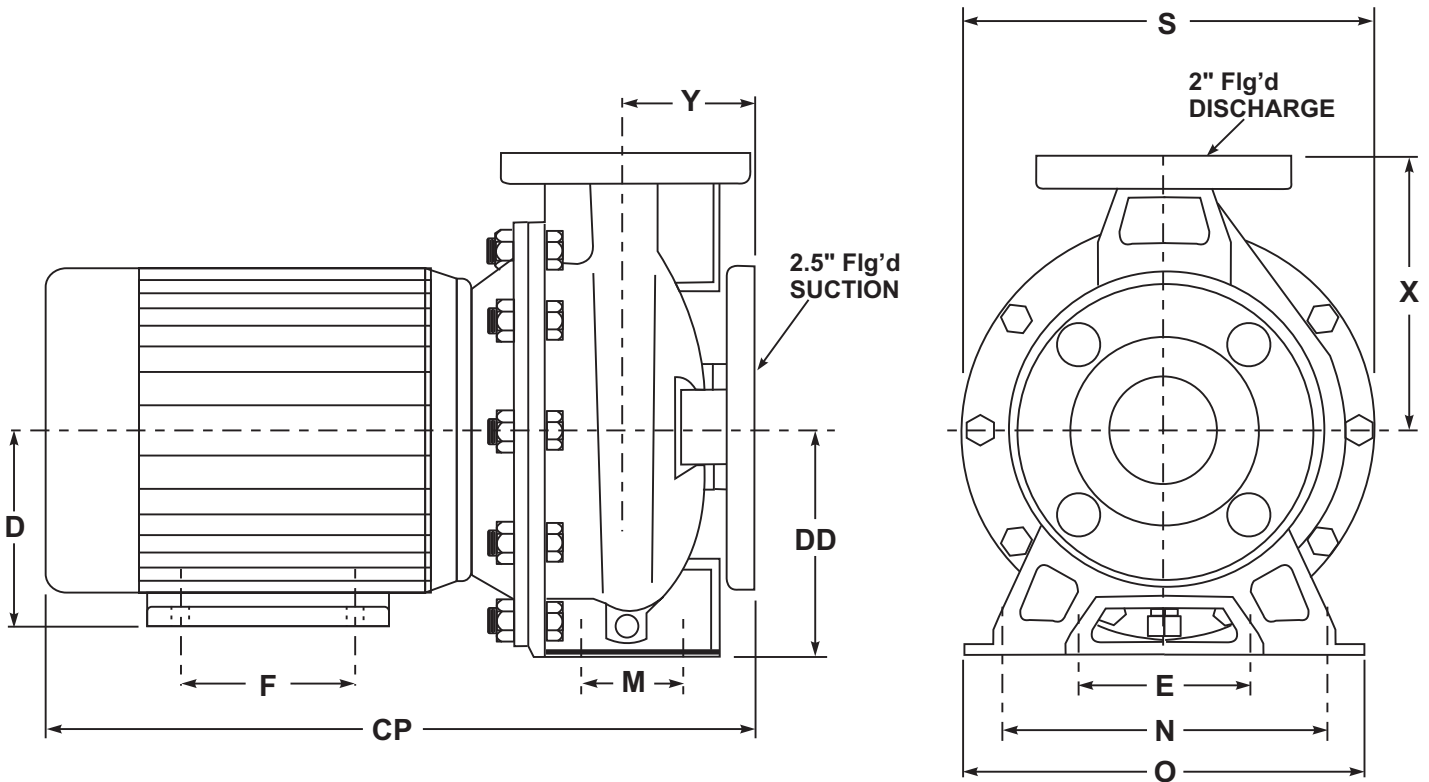

MOTOR FRAME	DIMENSIONS											WEIGHT (lbs)	
	CP*	F	E**	D	DD	M	N	O	S	X	Y	PUMP	MOTOR
143JM	17.75	4.0	5.5	3.50	5.19	2.75	7.5	9.44	10	6.31	3.94	22	44
145JM	18.75	5.0	5.5	3.50	5.19	2.75	7.5	9.44	10	6.31	3.94	22	44
182JM	19.50	4.5	7.5	4.50	5.19	2.75	7.5	9.44	10	6.31	3.94	22	90
184JM	20.50	5.5	7.5	4.50	5.19	2.75	7.5	9.44	10	6.31	3.94	22	110
213JM	22.25	5.5	8.5	5.25	5.19	2.75	7.5	9.44	10	6.31	3.94	22	120
215JM	23.75	7.0	8.5	5.25	5.19	2.75	7.5	9.44	10	6.31	3.94	22	160

NOTES - Not for construction purposes unless certified above.  
 - All dimensions in inches.  
 - Some dimensions may vary +/- 0.25 inches.  
 - \* Approximate only.  
 - \*\* Motor mount hole spacing.





# SERIES PS - DIMENSIONAL OUTLINE

## MODEL - PSF2002

CUSTOMER - \_\_\_\_\_  
 CUSTOMER REF. - \_\_\_\_\_ OUR REF. - \_\_\_\_\_  
 HP - \_\_\_\_\_ RPM - \_\_\_\_\_ VOLTAGE - \_\_\_\_\_ ENCL. - \_\_\_\_\_

CERTIFIED - \_\_\_\_\_ DATE - \_\_\_\_\_

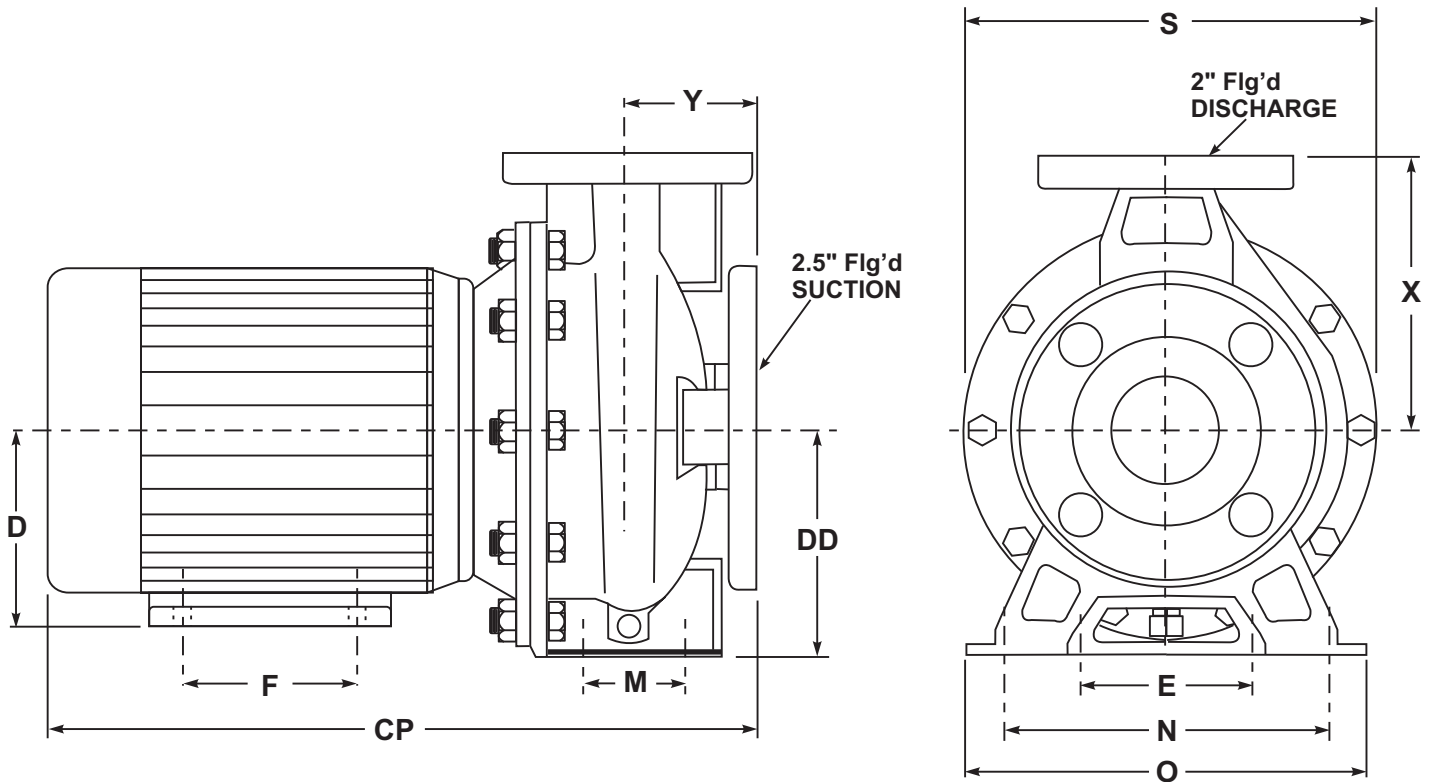

MOTOR FRAME	DIMENSIONS											WEIGHT (lbs)	
	CP*	F	E**	D	DD	M	N	O	S	X	Y	PUMP	MOTOR
143JM	17.75	4.0	5.5	3.50	5.19	2.75	7.5	9.44	10	6.31	3.94	22	44
145JM	18.75	5.0	5.5	3.50	5.19	2.75	7.5	9.44	10	6.31	3.94	22	44
182JM	19.50	4.5	7.5	4.50	5.19	2.75	7.5	9.44	10	6.31	3.94	22	90
184JM	20.50	5.5	7.5	4.50	5.19	2.75	7.5	9.44	10	6.31	3.94	22	110
213JM	22.25	5.5	8.5	5.25	5.19	2.75	7.5	9.44	10	6.31	3.94	22	120
215JM	23.75	7.0	8.5	5.25	5.19	2.75	7.5	9.44	10	6.31	3.94	22	160

NOTES - Not for construction purposes unless certified above.  
 - All dimensions in inches.  
 - Some dimensions may vary +/- 0.25 inches.  
 - \* Approximate only.  
 - \*\* Motor mount hole spacing.



# SERIES PS - DIMENSIONAL OUTLINE

## MODEL - PSF2003

CUSTOMER - \_\_\_\_\_  
 CUSTOMER REF. - \_\_\_\_\_ OUR REF. - \_\_\_\_\_  
 HP - \_\_\_\_\_ RPM - \_\_\_\_\_ VOLTAGE - \_\_\_\_\_ ENCL. - \_\_\_\_\_

CERTIFIED - \_\_\_\_\_ DATE - \_\_\_\_\_

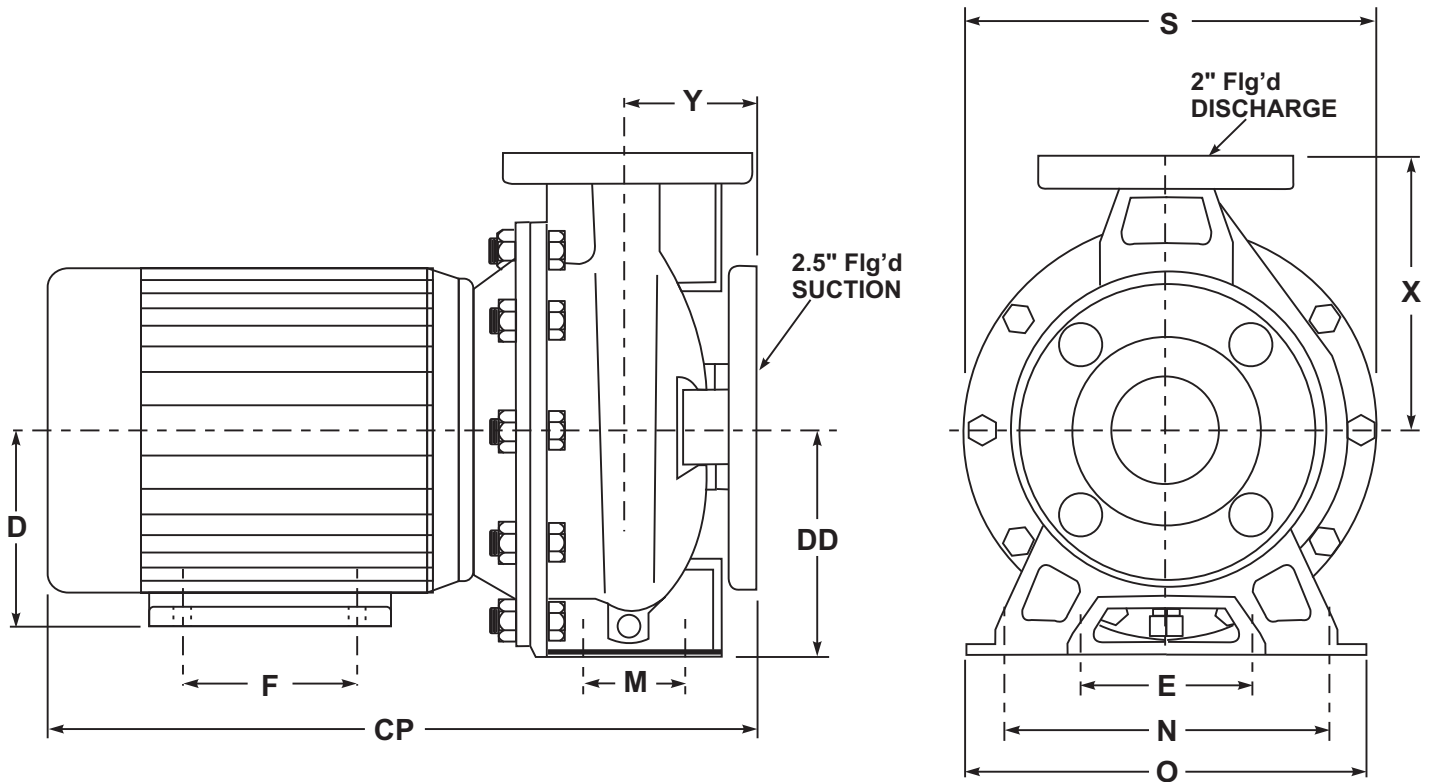

MOTOR FRAME	DIMENSIONS											WEIGHT (lbs)	
	CP*	F	E**	D	DD	M	N	O	S	X	Y	PUMP	MOTOR
143JM	17.75	4.0	5.5	3.50	6.31	2.75	8.38	10.44	11.69	7.06	3.94	22	44
145JM	18.75	5.0	5.5	3.50	6.31	2.75	8.38	10.44	11.69	7.06	3.94	22	44
182JM	19.50	4.5	7.5	4.50	6.31	2.75	8.38	10.44	11.69	7.06	3.94	22	90
184JM	20.50	5.5	7.5	4.50	6.31	2.75	8.38	10.44	11.69	7.06	3.94	22	110
213JM	22.25	5.5	8.5	5.25	6.31	2.75	8.38	10.44	11.69	7.06	3.94	22	120
215JM	23.75	7.0	8.5	5.25	6.31	2.75	8.38	10.44	11.69	7.06	3.94	22	160

NOTES - Not for construction purposes unless certified above.  
 - All dimensions in inches.  
 - Some dimensions may vary +/- 0.25 inches.  
 - \* Approximate only.  
 - \*\* Motor mount hole spacing.



# SERIES PS - DIMENSIONAL OUTLINE

## MODEL - PSF2004

CUSTOMER - \_\_\_\_\_  
 CUSTOMER REF. - \_\_\_\_\_ OUR REF. - \_\_\_\_\_  
 HP - \_\_\_\_\_ RPM - \_\_\_\_\_ VOLTAGE - \_\_\_\_\_ ENCL. - \_\_\_\_\_

CERTIFIED - \_\_\_\_\_ DATE - \_\_\_\_\_

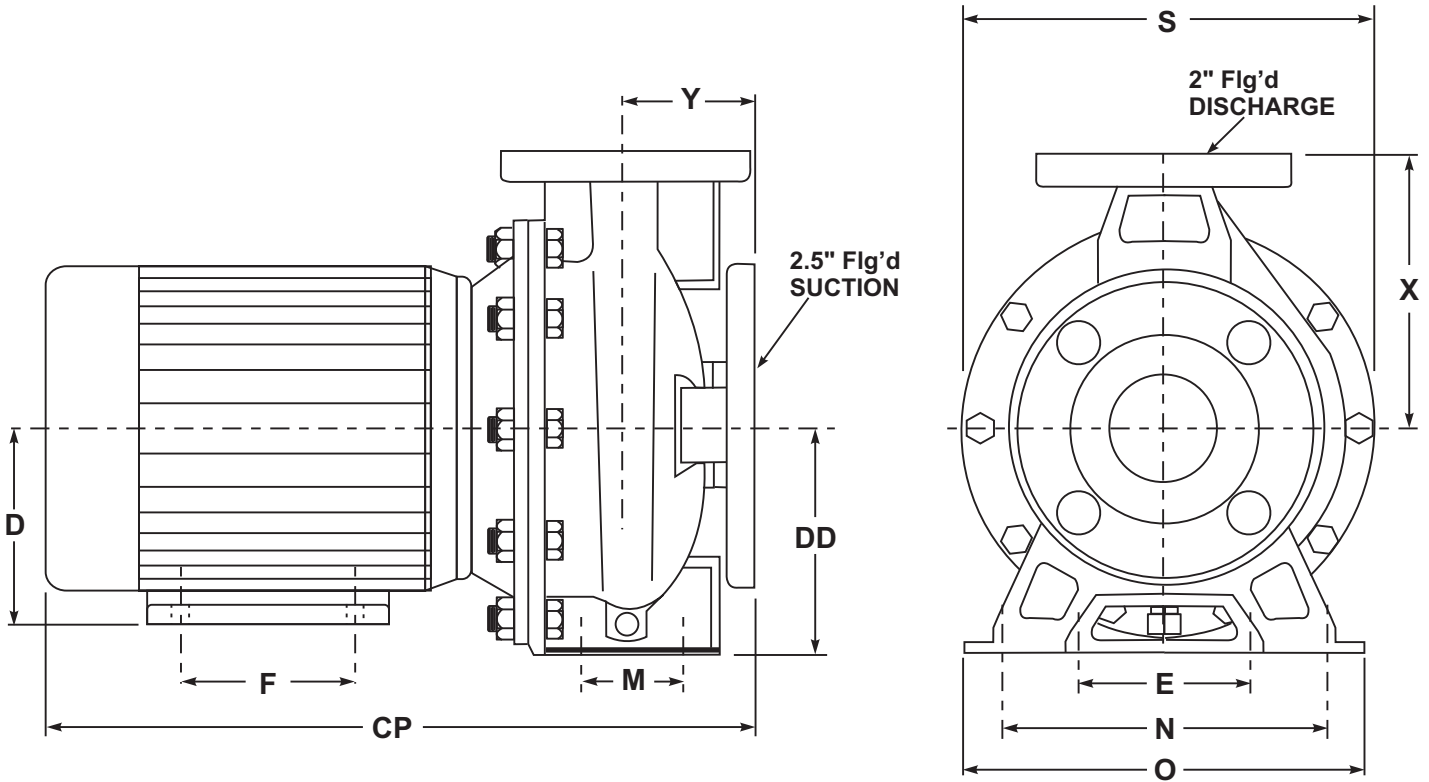

MOTOR FRAME	DIMENSIONS											WEIGHT (lbs)	
	CP*	F	E**	D	DD	M	N	O	S	X	Y	PUMP	MOTOR
143JM	17.75	4.0	5.5	3.50	6.31	2.75	8.38	10.44	11.69	7.06	3.94	22	44
145JM	18.75	5.0	5.5	3.50	6.31	2.75	8.38	10.44	11.69	7.06	3.94	22	44
182JM	19.50	4.5	7.5	4.50	6.31	2.75	8.38	10.44	11.69	7.06	3.94	22	90
184JM	20.50	5.5	7.5	4.50	6.31	2.75	8.38	10.44	11.69	7.06	3.94	22	110
213JM	22.25	5.5	8.5	5.25	6.31	2.75	8.38	10.44	11.69	7.06	3.94	22	120
215JM	23.75	7.0	8.5	5.25	6.31	2.75	8.38	10.44	11.69	7.06	3.94	22	160

NOTES - Not for construction purposes unless certified above.  
 - All dimensions in inches.  
 - Some dimensions may vary +/- 0.25 inches.  
 - \* Approximate only.  
 - \*\* Motor mount hole spacing.



**FLO-FAB**  
Montréal, Québec

**SERIES PS - DIMENSIONAL OUTLINE**  
**MODEL - PSF3001 thru PSF3004**

CUSTOMER - \_\_\_\_\_  
CUSTOMER REF. - \_\_\_\_\_ OUR REF. - \_\_\_\_\_  
HP - \_\_\_\_\_ RPM - \_\_\_\_\_ VOLTAGE - \_\_\_\_\_ ENCL. - \_\_\_\_\_

CERTIFIED - \_\_\_\_\_ DATE - \_\_\_\_\_

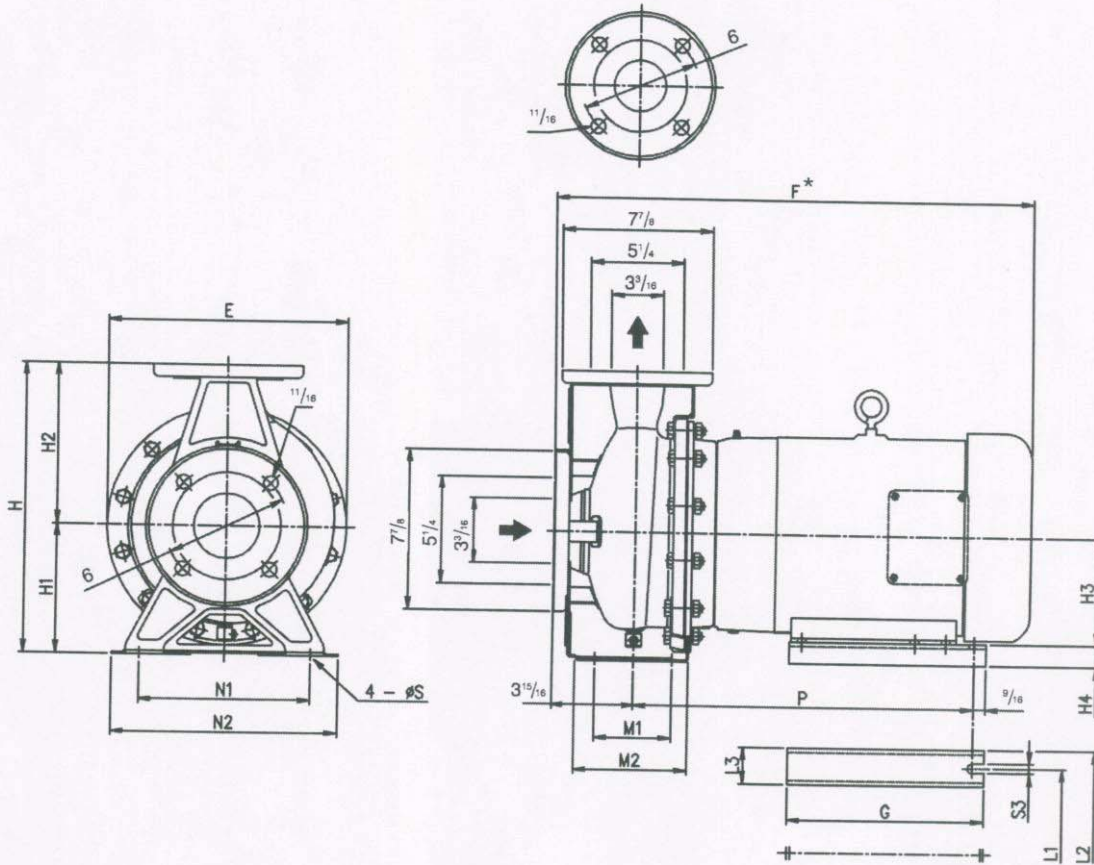

**Dimensions: inch**

MODEL	SIZE	TYPE	E	F	G	H	H <sub>1</sub>	H <sub>2</sub>	H <sub>3</sub>	H <sub>4</sub>	L <sub>1</sub>	L <sub>2</sub>	L <sub>3</sub>	M <sub>1</sub>	M <sub>2</sub>	N <sub>1</sub>	N <sub>2</sub>	P	S	S <sub>3</sub>
PSF3001/7.5	2 1/2 x 3 x 4 7/8	1	10	23 3/16	9 9/16	13 3/8	6 5/16	7 1/16	5 1/4	1 1/16	8 1/2	10 1/4	1 3/4	3 3/4	5 1/2	8 3/8	11	16 9/16	9/16	1/2
PSF3002/10	2 1/2 x 3 x 5 5/16	1	10	23 3/16	9 9/16	13 3/8	6 5/16	7 1/16	5 1/4	1 1/16	8 1/2	10 1/4	1 3/4	3 3/4	5 1/2	8 3/8	11	16 9/16	9/16	1/2
PSF3003/10	2 1/2 x 3 x 5 3/8	1	11 5/8	23 3/16	9 9/16	14 3/16	6 5/16	7 1/8	5 1/4	1 1/16	8 1/2	10 1/4	1 3/4	3 3/4	5 1/2	8 3/8	11	16 9/16	9/16	1/2
PSF3004/15	2 1/2 x 3 x 5 7/8	1	11 5/8	23 3/16	9 9/16	14 3/16	6 5/16	7 1/8	5 1/4	1 1/16	8 1/2	10 1/4	1 3/4	3 3/4	5 1/2	8 3/8	11	16 9/16	9/16	1/2

NOTES - Not for construction purposes unless certified above.  
- All dimensions in inches.  
- \* Approximate only.





**FLO-FAB**  
Montréal, Québec

**SERIES PS - DIMENSIONAL OUTLINE**  
**MODEL - PSF3005 thru PSF3009**

CUSTOMER - \_\_\_\_\_  
CUSTOMER REF. - \_\_\_\_\_ OUR REF. - \_\_\_\_\_  
HP - \_\_\_\_\_ RPM - \_\_\_\_\_ VOLTAGE - \_\_\_\_\_ ENCL. - \_\_\_\_\_

CERTIFIED - \_\_\_\_\_ DATE - \_\_\_\_\_

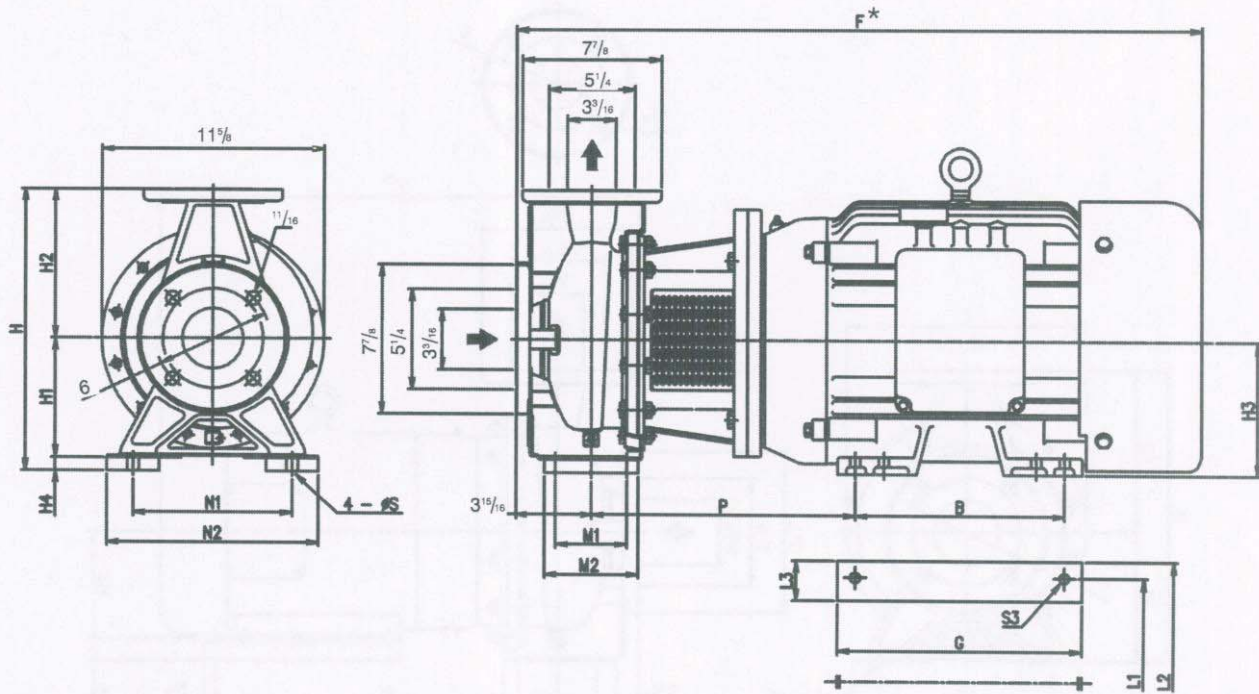

**Dimensions: inch**

MODEL	SIZE	TYPE	B	F	G	H	H <sub>1</sub>	H <sub>2</sub>	H <sub>3</sub>	H <sub>4</sub>	L <sub>1</sub>	L <sub>2</sub>	L <sub>3</sub>	M <sub>1</sub>	M <sub>2</sub>	N <sub>1</sub>	N <sub>2</sub>	P	S	S <sub>3</sub>
PSF3005/20	2 1/2 x 3 x 6 5/16	3	10	32 3/8	11 5/8	14 3/16	6 5/16	7 7/8	6 1/4	1/16	10	12 3/8	2 3/8	3 3/4	5 1/2	8 3/8	11	13 13/16	9/16	17/32
PSF3006/25	2 1/2 x 3 x 6 7/8	3	11	36	12 13/16	14 7/8	6 5/16	7 7/8	7	11/16	11	12 3/4	-	3 3/4	4 15/16	8 3/8	11 1/8	13 7/8	9/16	17/32
PSF3007/20	2 1/2 x 3 x 6 3/4	3	3/4	32 3/8	13 9/16	15 15/16	7 1/16	8 7/8	6 1/4	13/16	10	12 3/8	2 3/8	3 3/4	5 1/2	9 13/16	12 5/8	25 13/16	9/16	9/16
PSF3008/25	2 1/2 x 3 x 7 1/16	3	11	36	13	15 15/16	7 1/16	8 7/8	7	1/16	11	12 15/16	1 15/16	3 3/4	5 1/2	9 13/16	12 5/8	13 7/8	9/16	17/32
PSF3009/30	2 1/2 x 3 x 7 1/2	3	11	36	13	15 15/16	7 1/16	8 7/8	7	1/16	11	12 15/16	1 15/16	3 3/4	5 1/2	9 13/16	12 5/8	13 7/8	9/16	17/32

NOTES - Not for construction purposes unless certified above.  
- All dimensions in inches.  
- \* Approximate only.





**SERIES PS - DIMENSIONAL OUTLINE  
MODEL - PSF701**

CUSTOMER - \_\_\_\_\_  
 CUSTOMER REF. - \_\_\_\_\_ OUR REF. - \_\_\_\_\_  
 HP - \_\_\_\_\_ RPM - \_\_\_\_\_ VOLTAGE - \_\_\_\_\_ ENCL. - \_\_\_\_\_

CERTIFIED - \_\_\_\_\_ DATE - \_\_\_\_\_

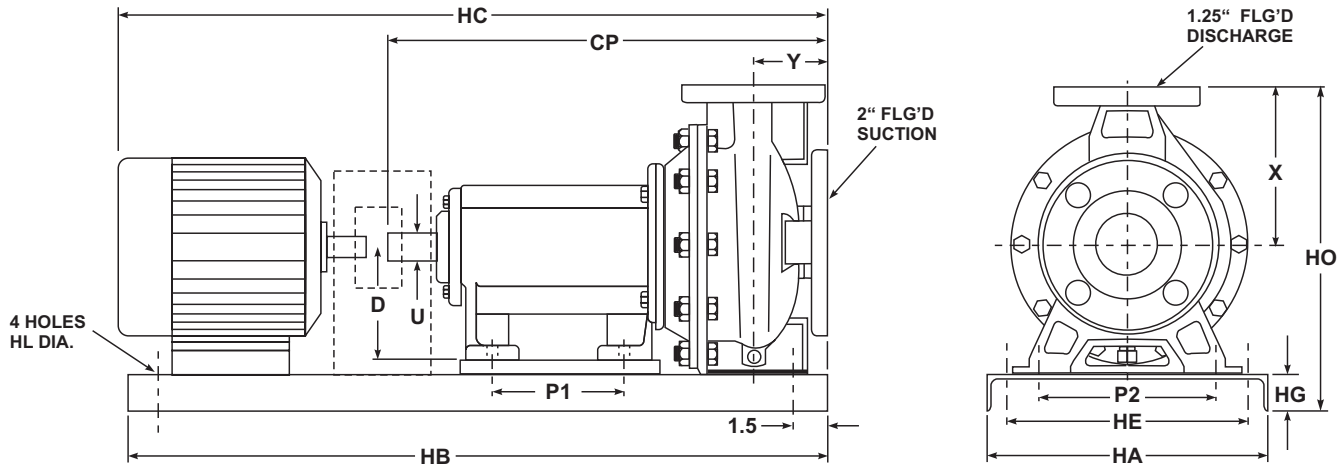

MOTOR FRAME	DIMENSIONS														WEIGHT (lbs)*		
	HA	HB	HL	HC*	HO	HG	HE	CP	P1	P2	D**	U	X	Y	PUMP	MOTOR	ASS'Y
56	10	35	0.62	33.0	13.38	2.62	7.0	20.5	5.75	5.62	5.25	1.25	5.50	3.12	80	30	155
143T	10	35	0.62	34.0	13.38	2.62	7.0	20.5	5.75	5.62	5.25	1.25	5.50	3.12	80	40	165
145T	10	35	0.62	34.0	13.38	2.62	7.0	20.5	5.75	5.62	5.25	1.25	5.50	3.12	80	40	165
182T	10	35	0.62	35.0	13.38	2.62	7.0	20.5	5.75	5.62	5.25	1.25	5.50	3.12	80	80	205
184T	10	35	0.62	35.0	13.38	2.62	7.0	20.5	5.75	5.62	5.25	1.25	5.50	3.12	80	80	205

NOTES - Not for construction purposes unless certified above.  
 - All dimensions in inches.  
 - Some dimensions may vary +/- 0.25 inches.  
 - \* Approximate only.  
 - \*\* Shaft centerline to underside of frame feet.



**SERIES PS - DIMENSIONAL OUTLINE  
MODEL - PSF702**

CUSTOMER - \_\_\_\_\_  
 CUSTOMER REF. - \_\_\_\_\_ OUR REF. - \_\_\_\_\_  
 HP - \_\_\_\_\_ RPM - \_\_\_\_\_ VOLTAGE - \_\_\_\_\_ ENCL. - \_\_\_\_\_

CERTIFIED - \_\_\_\_\_ DATE - \_\_\_\_\_

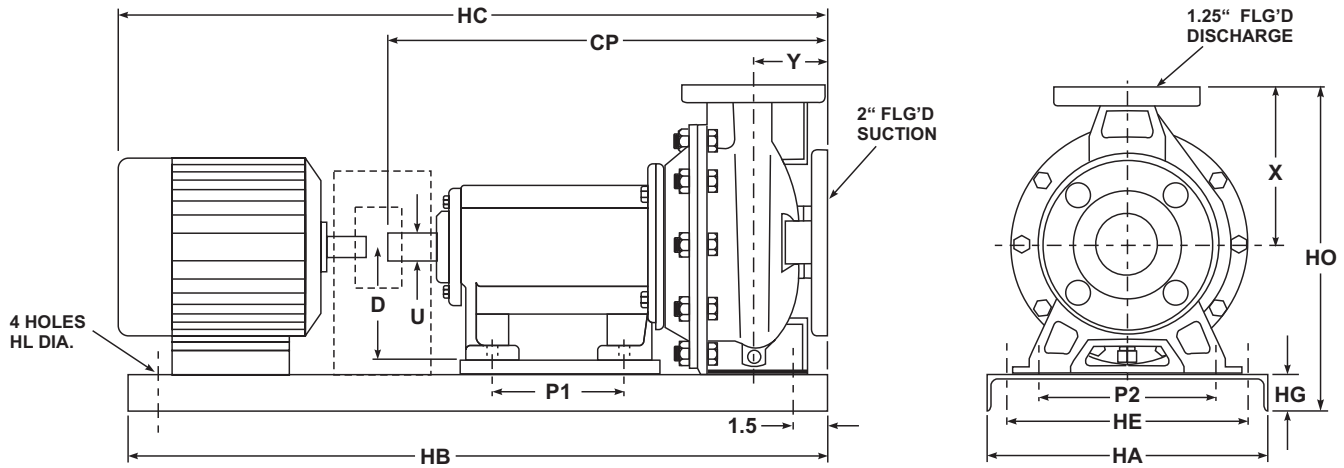

MOTOR FRAME	DIMENSIONS													WEIGHT (lbs)*			
	HA	HB	HL	HC*	HO	HG	HE	CP	P1	P2	D**	U	X	Y	PUMP	MOTOR	ASS'Y
56	10	35	0.62	33.0	14.81	2.62	7.0	20.5	5.75	5.62	5.25	1.25	6.31	3.12	80	30	155
143T	10	35	0.62	34.0	14.81	2.62	7.0	20.5	5.75	5.62	5.25	1.25	6.31	3.12	80	40	165
145T	10	35	0.62	34.0	14.81	2.62	7.0	20.5	5.75	5.62	5.25	1.25	6.31	3.12	80	40	165
182T	10	35	0.62	35.0	14.81	2.62	7.0	20.5	5.75	5.62	5.25	1.25	6.31	3.12	80	80	205
184T	10	35	0.62	35.0	14.81	2.62	7.0	20.5	5.75	5.62	5.25	1.25	6.31	3.12	80	80	205

NOTES - Not for construction purposes unless certified above.  
 - All dimensions in inches.  
 - Some dimensions may vary +/- 0.25 inches.  
 - \* Approximate only.  
 - \*\* Shaft centerline to underside of frame feet.



**SERIES PS - DIMENSIONAL OUTLINE  
MODEL - PSF703**

CUSTOMER - \_\_\_\_\_  
 CUSTOMER REF. - \_\_\_\_\_ OUR REF. - \_\_\_\_\_  
 HP - \_\_\_\_\_ RPM - \_\_\_\_\_ VOLTAGE - \_\_\_\_\_ ENCL. - \_\_\_\_\_

CERTIFIED - \_\_\_\_\_ DATE - \_\_\_\_\_

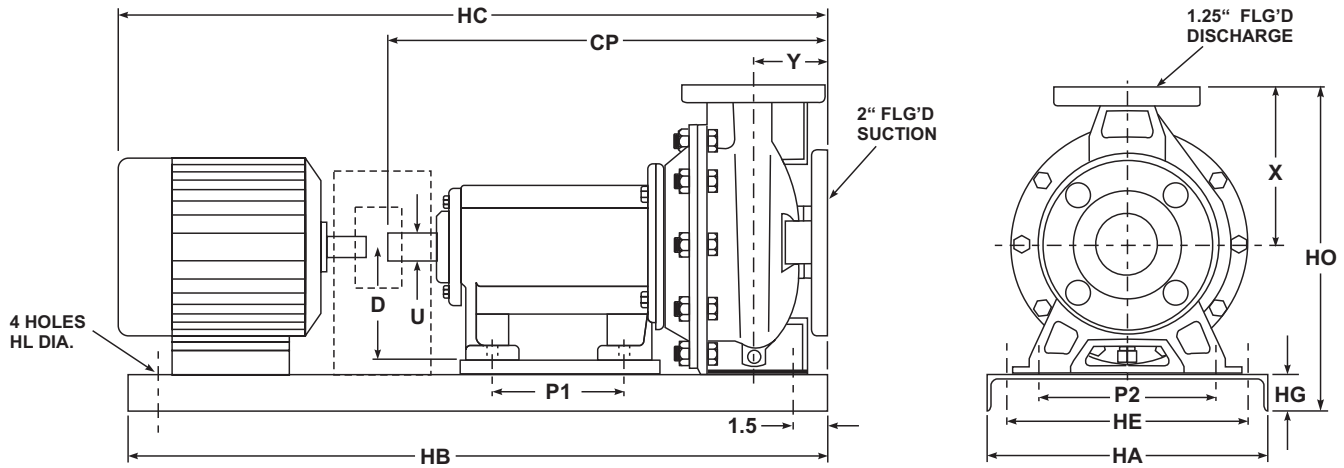

MOTOR FRAME	DIMENSIONS													WEIGHT (lbs)*			
	HA	HB	HL	HC*	HO	HG	HE	CP	P1	P2	D**	U	X	Y	PUMP	MOTOR	ASS'Y
56	10	35	0.62	33.0	14.81	2.62	7.0	20.5	5.75	5.62	5.25	1.25	6.31	3.12	80	30	155
143T	10	35	0.62	34.0	14.81	2.62	7.0	20.5	5.75	5.62	5.25	1.25	6.31	3.12	80	40	165
145T	10	35	0.62	34.0	14.81	2.62	7.0	20.5	5.75	5.62	5.25	1.25	6.31	3.12	80	40	165
182T	10	35	0.62	35.0	14.81	2.62	7.0	20.5	5.75	5.62	5.25	1.25	6.31	3.12	80	80	205
184T	10	35	0.62	35.0	14.81	2.62	7.0	20.5	5.75	5.62	5.25	1.25	6.31	3.12	80	80	205

NOTES - Not for construction purposes unless certified above.  
 - All dimensions in inches.  
 - Some dimensions may vary +/- 0.25 inches.  
 - \* Approximate only.  
 - \*\* Shaft centerline to underside of frame feet.



**SERIES PS - DIMENSIONAL OUTLINE  
MODEL - PSF704**

CUSTOMER - \_\_\_\_\_  
 CUSTOMER REF. - \_\_\_\_\_ OUR REF. - \_\_\_\_\_  
 HP - \_\_\_\_\_ RPM - \_\_\_\_\_ VOLTAGE - \_\_\_\_\_ ENCL. - \_\_\_\_\_

CERTIFIED - \_\_\_\_\_ DATE - \_\_\_\_\_

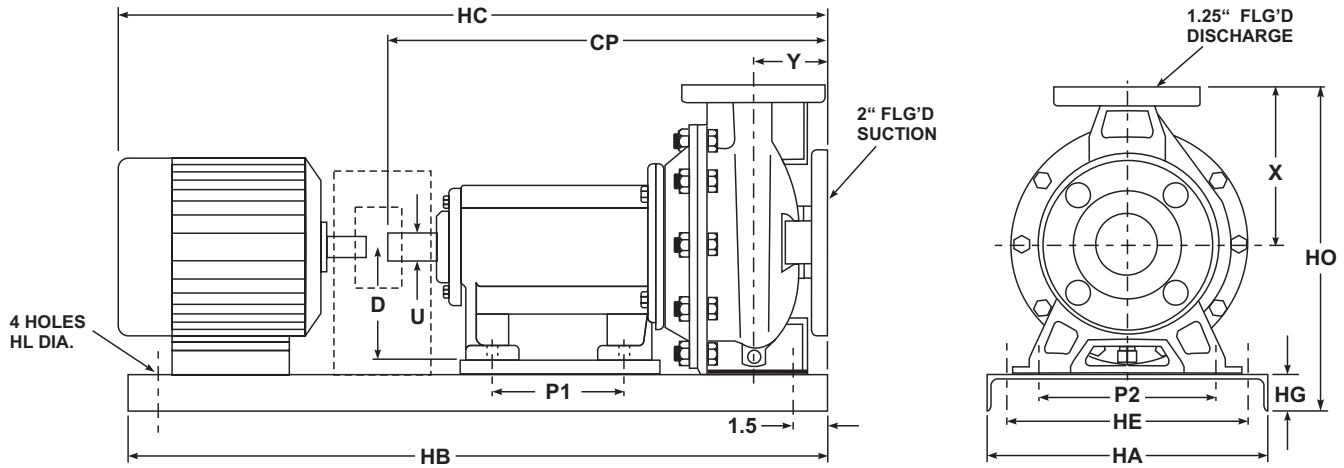

MOTOR FRAME	DIMENSIONS														WEIGHT (lbs)*		
	HA	HB	HL	HC*	HO	HG	HE	CP	P1	P2	D**	U	X	Y	PUMP	MOTOR	ASS'Y
56	10	35	0.62	33.0	16.06	2.62	7.0	20.88	5.75	5.62	5.25	1.25	7.06	3.12	80	30	155
143T	10	35	0.62	34.0	16.06	2.62	7.0	20.88	5.75	5.62	5.25	1.25	7.06	3.12	80	40	165
145T	10	35	0.62	34.0	16.06	2.62	7.0	20.88	5.75	5.62	5.25	1.25	7.06	3.12	80	40	165
182T	10	35	0.62	35.0	16.06	2.62	7.0	20.88	5.75	5.62	5.25	1.25	7.06	3.12	80	80	205
184T	10	35	0.62	35.0	16.06	2.62	7.0	20.88	5.75	5.62	5.25	1.25	7.06	3.12	80	80	205
213T	12	40	0.62	39.0	16.44	3.00	9.0	20.88	5.75	5.62	5.25	1.25	7.06	3.12	80	150	275
215T	12	40	0.62	39.0	16.44	3.00	9.0	20.88	5.75	5.62	5.25	1.25	7.06	3.12	80	150	275

NOTES - Not for construction purposes unless certified above.  
 - All dimensions in inches.  
 - Some dimensions may vary +/- 0.25 inches.  
 - \* Approximate only.  
 - \*\* Shaft centerline to underside of frame feet.



**SERIES PS - DIMENSIONAL OUTLINE  
MODEL - PSF705**

CUSTOMER - \_\_\_\_\_  
 CUSTOMER REF. - \_\_\_\_\_ OUR REF. - \_\_\_\_\_  
 HP - \_\_\_\_\_ RPM - \_\_\_\_\_ VOLTAGE - \_\_\_\_\_ ENCL. - \_\_\_\_\_

CERTIFIED - \_\_\_\_\_ DATE - \_\_\_\_\_

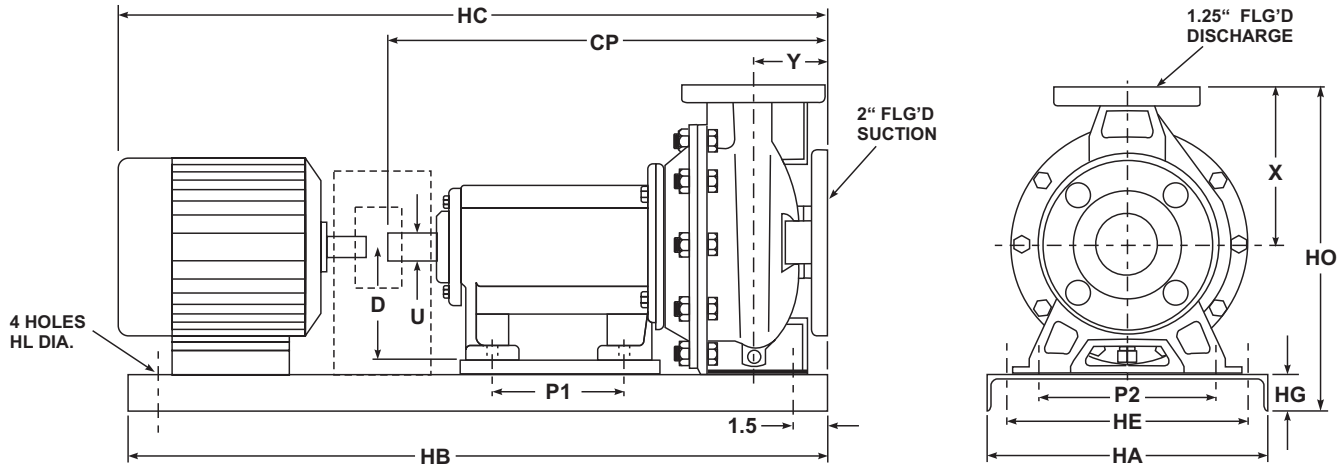

MOTOR FRAME	DIMENSIONS														WEIGHT (lbs)*		
	HA	HB	HL	HC*	HO	HG	HE	CP	P1	P2	D**	U	X	Y	PUMP	MOTOR	ASS'Y
56	10	35	0.62	33.0	16.06	2.62	7.0	20.88	5.75	5.62	5.25	1.25	7.06	3.12	80	30	155
143T	10	35	0.62	34.0	16.06	2.62	7.0	20.88	5.75	5.62	5.25	1.25	7.06	3.12	80	40	165
145T	10	35	0.62	34.0	16.06	2.62	7.0	20.88	5.75	5.62	5.25	1.25	7.06	3.12	80	40	165
182T	10	35	0.62	35.0	16.06	2.62	7.0	20.88	5.75	5.62	5.25	1.25	7.06	3.12	80	80	205
184T	10	35	0.62	35.0	16.06	2.62	7.0	20.88	5.75	5.62	5.25	1.25	7.06	3.12	80	80	205
213T	12	40	0.62	39.0	16.44	3.00	9.0	20.88	5.75	5.62	5.25	1.25	7.06	3.12	80	150	275
215T	12	40	0.62	39.0	16.44	3.00	9.0	20.88	5.75	5.62	5.25	1.25	7.06	3.12	80	150	275

NOTES - Not for construction purposes unless certified above.  
 - All dimensions in inches.  
 - Some dimensions may vary +/- 0.25 inches.  
 - \* Approximate only.  
 - \*\* Shaft centerline to underside of frame feet.





**SERIES PS - DIMENSIONAL OUTLINE  
MODEL - PSF1201**

CUSTOMER - \_\_\_\_\_  
 CUSTOMER REF. - \_\_\_\_\_ OUR REF. - \_\_\_\_\_  
 HP - \_\_\_\_\_ RPM - \_\_\_\_\_ VOLTAGE - \_\_\_\_\_ ENCL. - \_\_\_\_\_

CERTIFIED - \_\_\_\_\_ DATE - \_\_\_\_\_

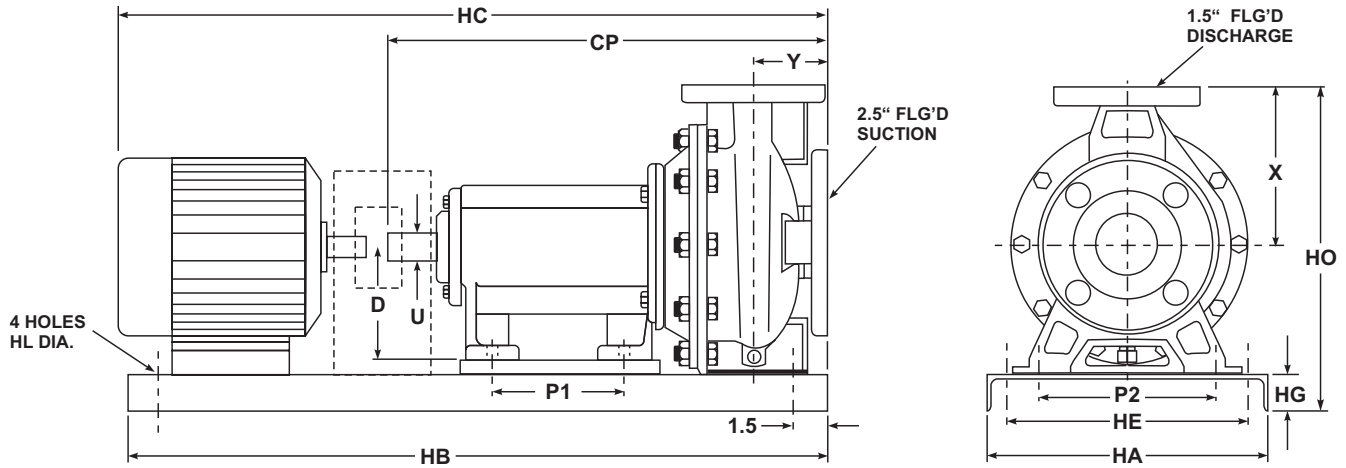

MOTOR FRAME	DIMENSIONS														WEIGHT (lbs)*		
	HA	HB	HL	HC*	HO	HG	HE	CP	P1	P2	D**	U	X	Y	PUMP	MOTOR	ASS'Y
56	10	35	0.62	32.0	13.38	2.62	7.0	20.12	5.75	5.62	5.25	1.25	5.50	3.12	80	30	155
143T	10	35	0.62	33.0	13.38	2.62	7.0	20.12	5.75	5.62	5.25	1.25	5.50	3.12	80	40	165
145T	10	35	0.62	33.0	13.38	2.62	7.0	20.12	5.75	5.62	5.25	1.25	5.50	3.12	80	40	165
182T	10	35	0.62	34.0	13.38	2.62	7.0	20.12	5.75	5.62	5.25	1.25	5.50	3.12	80	80	205
184T	10	35	0.62	34.0	13.38	2.62	7.0	20.12	5.75	5.62	5.25	1.25	5.50	3.12	80	80	205

NOTES - Not for construction purposes unless certified above.  
 - All dimensions in inches.  
 - Some dimensions may vary +/- 0.25 inches.  
 - \* Approximate only.  
 - \*\* Shaft centerline to underside of frame feet.



**SERIES PS - DIMENSIONAL OUTLINE  
MODEL - PSF1202**

CUSTOMER - \_\_\_\_\_  
 CUSTOMER REF. - \_\_\_\_\_ OUR REF. - \_\_\_\_\_  
 HP - \_\_\_\_\_ RPM - \_\_\_\_\_ VOLTAGE - \_\_\_\_\_ ENCL. - \_\_\_\_\_

CERTIFIED - \_\_\_\_\_ DATE - \_\_\_\_\_

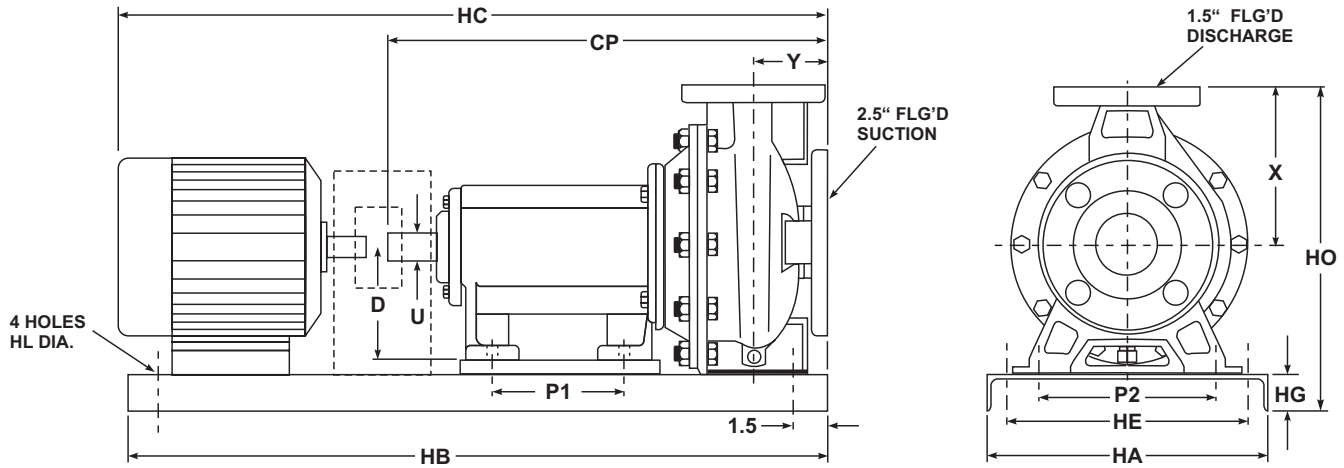

MOTOR FRAME	DIMENSIONS														WEIGHT (lbs)*		
	HA	HB	HL	HC*	HO	HG	HE	CP	P1	P2	D**	U	X	Y	PUMP	MOTOR	ASS'Y
56	10	35	0.62	32.0	13.38	2.62	7.0	20.12	5.75	5.62	5.25	1.25	5.50	3.12	80	30	155
143T	10	35	0.62	33.0	13.38	2.62	7.0	20.12	5.75	5.62	5.25	1.25	5.50	3.12	80	40	165
145T	10	35	0.62	33.0	13.38	2.62	7.0	20.12	5.75	5.62	5.25	1.25	5.50	3.12	80	40	165
182T	10	35	0.62	34.0	13.38	2.62	7.0	20.12	5.75	5.62	5.25	1.25	5.50	3.12	80	80	205
184T	10	35	0.62	34.0	13.38	2.62	7.0	20.12	5.75	5.62	5.25	1.25	5.50	3.12	80	80	205

NOTES - Not for construction purposes unless certified above.  
 - All dimensions in inches.  
 - Some dimensions may vary +/- 0.25 inches.  
 - \* Approximate only.  
 - \*\* Shaft centerline to underside of frame feet.



**SERIES PS - DIMENSIONAL OUTLINE  
MODEL - PSF1203**

CUSTOMER - \_\_\_\_\_  
 CUSTOMER REF. - \_\_\_\_\_ OUR REF. - \_\_\_\_\_  
 HP - \_\_\_\_\_ RPM - \_\_\_\_\_ VOLTAGE - \_\_\_\_\_ ENCL. - \_\_\_\_\_

CERTIFIED - \_\_\_\_\_ DATE - \_\_\_\_\_

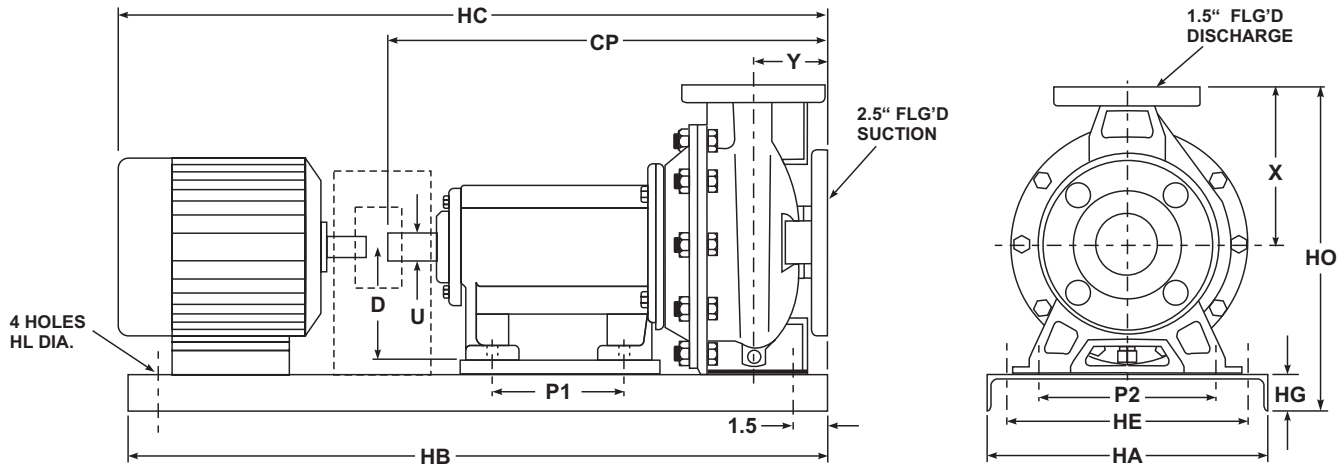

MOTOR FRAME	DIMENSIONS														WEIGHT (lbs)*		
	HA	HB	HL	HC*	HO	HG	HE	CP	P1	P2	D**	U	X	Y	PUMP	MOTOR	ASS'Y
56	10	35	0.62	33.0	14.19	2.62	7.0	21.0	5.75	5.62	5.25	1.25	6.31	3.12	85	30	160
143T	10	35	0.62	34.0	14.19	2.62	7.0	21.0	5.75	5.62	5.25	1.25	6.31	3.12	85	40	170
145T	10	35	0.62	34.0	14.19	2.62	7.0	21.0	5.75	5.62	5.25	1.25	6.31	3.12	85	40	170
182T	10	35	0.62	35.0	14.19	2.62	7.0	21.0	5.75	5.62	5.25	1.25	6.31	3.12	85	80	210
184T	10	35	0.62	35.0	14.19	2.62	7.0	21.0	5.75	5.62	5.25	1.25	6.31	3.12	85	80	210
213T	12	40	0.62	39.0	14.56	3.00	9.0	21.0	5.75	5.62	5.25	1.25	6.31	3.12	85	150	370
215T	12	40	0.62	39.0	14.56	3.00	9.0	21.0	5.75	5.62	5.25	1.25	6.31	3.12	85	150	370

NOTES - Not for construction purposes unless certified above.  
 - All dimensions in inches.  
 - Some dimensions may vary +/- 0.25 inches.  
 - \* Approximate only.  
 - \*\* Shaft centerline to underside of frame feet.



**SERIES PS - DIMENSIONAL OUTLINE  
MODEL - PSF1204**

CUSTOMER - \_\_\_\_\_  
 CUSTOMER REF. - \_\_\_\_\_ OUR REF. - \_\_\_\_\_  
 HP - \_\_\_\_\_ RPM - \_\_\_\_\_ VOLTAGE - \_\_\_\_\_ ENCL. - \_\_\_\_\_

CERTIFIED - \_\_\_\_\_ DATE - \_\_\_\_\_

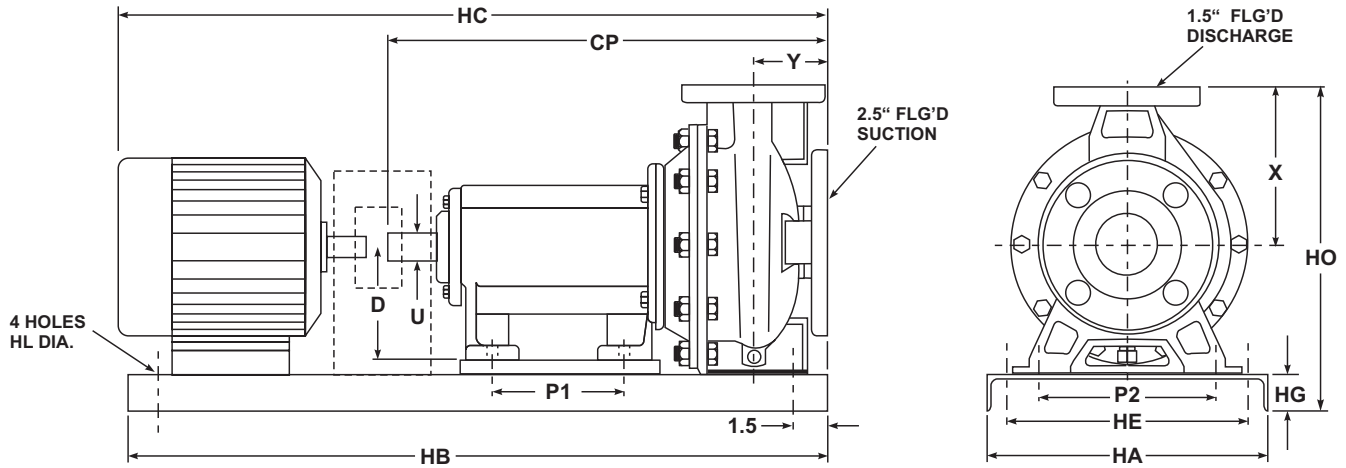

MOTOR FRAME	DIMENSIONS													WEIGHT (lbs)*			
	HA	HB	HL	HC*	HO	HG	HE	CP	P1	P2	D**	U	X	Y	PUMP	MOTOR	ASS'Y
56	10	35	0.62	33.0	14.19	2.62	7.0	21.0	5.75	5.62	5.25	1.25	6.31	3.12	85	30	160
143T	10	35	0.62	34.0	14.19	2.62	7.0	21.0	5.75	5.62	5.25	1.25	6.31	3.12	85	40	170
145T	10	35	0.62	34.0	14.19	2.62	7.0	21.0	5.75	5.62	5.25	1.25	6.31	3.12	85	40	170
182T	10	35	0.62	35.0	14.19	2.62	7.0	21.0	5.75	5.62	5.25	1.25	6.31	3.12	85	80	210
184T	10	35	0.62	35.0	14.19	2.62	7.0	21.0	5.75	5.62	5.25	1.25	6.31	3.12	85	80	210
213T	12	40	0.62	39.0	14.56	3.00	9.0	21.0	5.75	5.62	5.25	1.25	6.31	3.12	85	150	370
215T	12	40	0.62	39.0	14.56	3.00	9.0	21.0	5.75	5.62	5.25	1.25	6.31	3.12	85	150	370

NOTES - Not for construction purposes unless certified above.  
 - All dimensions in inches.  
 - Some dimensions may vary +/- 0.25 inches.  
 - \* Approximate only.  
 - \*\* Shaft centerline to underside of frame feet.



**SERIES PS - DIMENSIONAL OUTLINE  
MODEL - PSF1205**

CUSTOMER - \_\_\_\_\_  
 CUSTOMER REF. - \_\_\_\_\_ OUR REF. - \_\_\_\_\_  
 HP - \_\_\_\_\_ RPM - \_\_\_\_\_ VOLTAGE - \_\_\_\_\_ ENCL. - \_\_\_\_\_

CERTIFIED - \_\_\_\_\_ DATE - \_\_\_\_\_

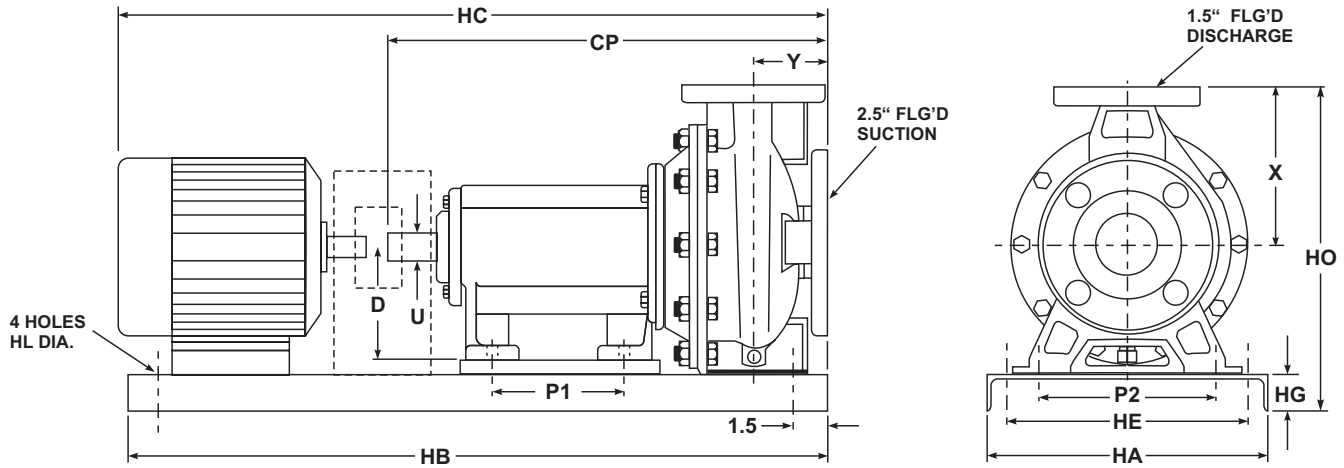

MOTOR FRAME	DIMENSIONS														WEIGHT (lbs)*		
	HA	HB	HL	HC*	HO	HG	HE	CP	P1	P2	D**	U	X	Y	PUMP	MOTOR	ASS'Y
56	10	35	0.62	34.0	16.06	2.62	7.0	22.0	5.75	5.62	5.25	1.25	7.06	3.94	85	30	160
143T	10	35	0.62	34.0	16.06	2.62	7.0	22.0	5.75	5.62	5.25	1.25	7.06	3.94	85	40	170
145T	10	35	0.62	34.0	16.06	2.62	7.0	22.0	5.75	5.62	5.25	1.25	7.06	3.94	85	40	170
182T	10	35	0.62	35.0	16.06	2.62	7.0	22.0	5.75	5.62	5.25	1.25	7.06	3.94	85	80	210
184T	10	35	0.62	35.0	16.06	2.62	7.0	22.0	5.75	5.62	5.25	1.25	7.06	3.94	85	80	210
213T	12	40	0.62	41.0	16.44	3.00	9.0	22.0	5.75	5.62	5.25	1.25	7.06	3.94	85	150	365
215T	12	40	0.62	41.0	16.44	3.00	9.0	22.0	5.75	5.62	5.25	1.25	7.06	3.94	85	150	365
254T	15	48	0.75	46.0	16.81	3.38	12.0	22.0	5.75	5.62	5.25	1.25	7.06	3.94	85	250	490

NOTES - Not for construction purposes unless certified above.  
 - All dimensions in inches.  
 - Some dimensions may vary +/- 0.25 inches.  
 - \* Approximate only.  
 - \*\* Shaft centerline to underside of frame feet.





**SERIES PS - DIMENSIONAL OUTLINE  
MODEL - PSF1206**

CUSTOMER - \_\_\_\_\_  
 CUSTOMER REF. - \_\_\_\_\_ OUR REF. - \_\_\_\_\_  
 HP - \_\_\_\_\_ RPM - \_\_\_\_\_ VOLTAGE - \_\_\_\_\_ ENCL. - \_\_\_\_\_

CERTIFIED - \_\_\_\_\_ DATE - \_\_\_\_\_

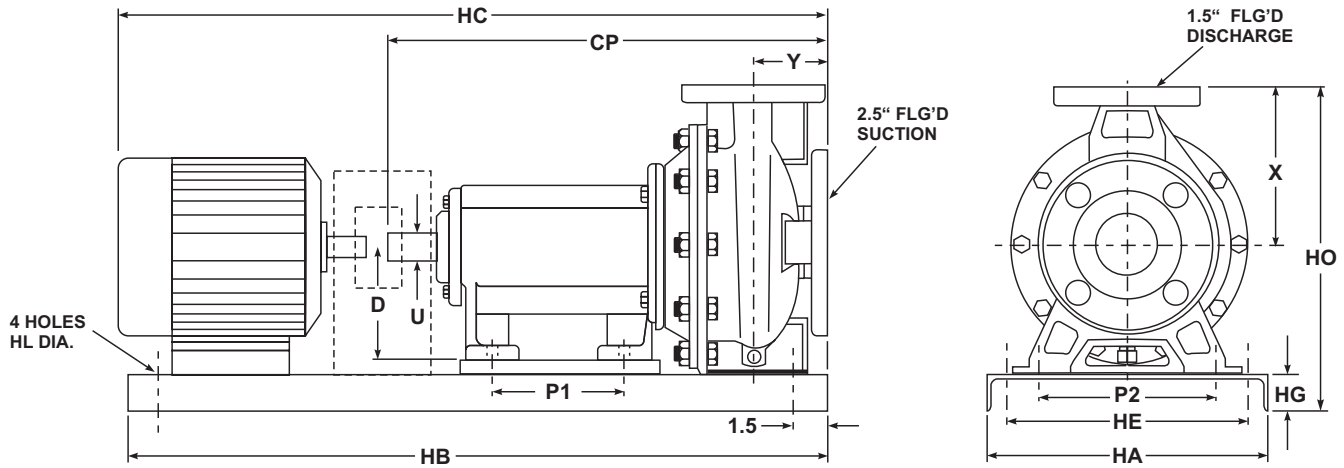

MOTOR FRAME	DIMENSIONS														WEIGHT (lbs)*		
	HA	HB	HL	HC*	HO	HG	HE	CP	P1	P2	D**	U	X	Y	PUMP	MOTOR	ASS'Y
56	10	35	0.62	34.0	16.06	2.62	7.0	22.0	5.75	5.62	5.25	1.25	7.06	3.94	85	30	160
143T	10	35	0.62	34.0	16.06	2.62	7.0	22.0	5.75	5.62	5.25	1.25	7.06	3.94	85	40	170
145T	10	35	0.62	34.0	16.06	2.62	7.0	22.0	5.75	5.62	5.25	1.25	7.06	3.94	85	40	170
182T	10	35	0.62	35.0	16.06	2.62	7.0	22.0	5.75	5.62	5.25	1.25	7.06	3.94	85	80	210
184T	10	35	0.62	35.0	16.06	2.62	7.0	22.0	5.75	5.62	5.25	1.25	7.06	3.94	85	80	210
213T	12	40	0.62	41.0	16.44	3.00	9.0	22.0	5.75	5.62	5.25	1.25	7.06	3.94	85	150	365
215T	12	40	0.62	41.0	16.44	3.00	9.0	22.0	5.75	5.62	5.25	1.25	7.06	3.94	85	150	365
254T	15	48	0.75	46.0	16.81	3.38	12.0	22.0	5.75	5.62	5.25	1.25	7.06	3.94	85	250	490

NOTES - Not for construction purposes unless certified above.  
 - All dimensions in inches.  
 - Some dimensions may vary +/- 0.25 inches.  
 - \* Approximate only.  
 - \*\* Shaft centerline to underside of frame feet.



**SERIES PS - DIMENSIONAL OUTLINE  
MODEL - PSF2001**

CUSTOMER - \_\_\_\_\_  
 CUSTOMER REF. - \_\_\_\_\_ OUR REF. - \_\_\_\_\_  
 HP - \_\_\_\_\_ RPM - \_\_\_\_\_ VOLTAGE - \_\_\_\_\_ ENCL. - \_\_\_\_\_

CERTIFIED - \_\_\_\_\_ DATE - \_\_\_\_\_

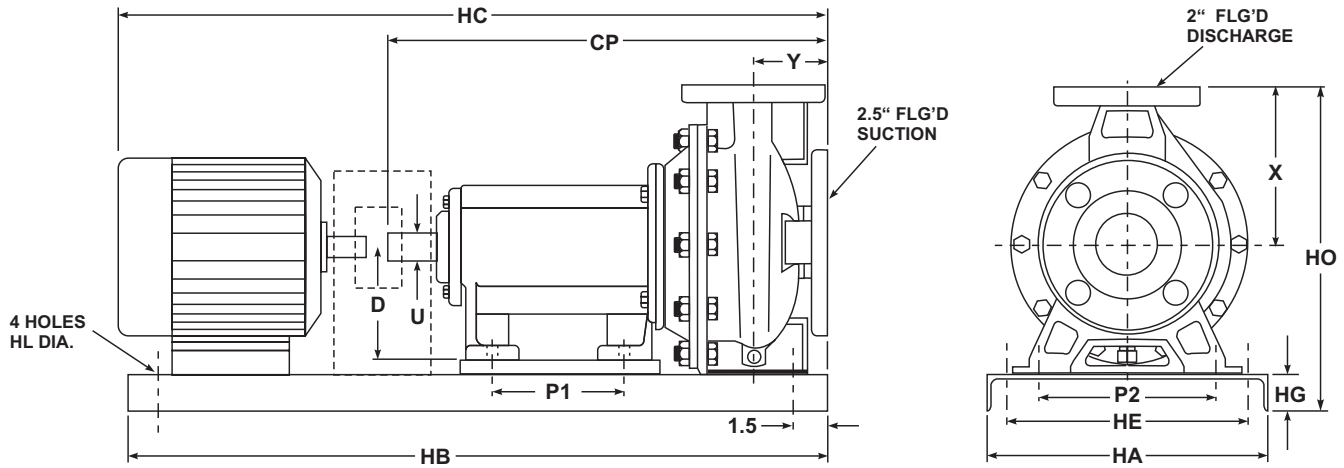

MOTOR FRAME	DIMENSIONS														WEIGHT (lbs)*		
	HA	HB	HL	HC*	HO	HG	HE	CP	P1	P2	D**	U	X	Y	PUMP	MOTOR	ASS'Y
56	10	35	0.62	33.0	14.19	2.62	7.0	22.0	5.75	5.62	5.25	1.25	6.31	3.94	90	30	165
143T	10	35	0.62	34.0	14.19	2.62	7.0	22.0	5.75	5.62	5.25	1.25	6.31	3.94	90	40	175
145T	10	35	0.62	34.0	14.19	2.62	7.0	22.0	5.75	5.62	5.25	1.25	6.31	3.94	90	40	175
182T	10	35	0.62	35.0	14.19	2.62	7.0	22.0	5.75	5.62	5.25	1.25	6.31	3.94	90	80	215
184T	10	35	0.62	35.0	14.19	2.62	7.0	22.0	5.75	5.62	5.25	1.25	6.31	3.94	90	80	215
213T	12	40	0.62	40.0	14.56	3.00	9.0	22.0	5.75	5.62	5.25	1.25	6.31	3.94	90	150	370
215T	12	40	0.62	40.0	14.56	3.00	9.0	22.0	5.75	5.62	5.25	1.25	6.31	3.94	90	150	370

NOTES - Not for construction purposes unless certified above.  
 - All dimensions in inches.  
 - Some dimensions may vary +/- 0.25 inches.  
 - \* Approximate only.  
 - \*\* Shaft centerline to underside of frame feet.



**SERIES PS - DIMENSIONAL OUTLINE  
MODEL - PSF2002**

CUSTOMER - \_\_\_\_\_  
 CUSTOMER REF. - \_\_\_\_\_ OUR REF. - \_\_\_\_\_  
 HP - \_\_\_\_\_ RPM - \_\_\_\_\_ VOLTAGE - \_\_\_\_\_ ENCL. - \_\_\_\_\_

CERTIFIED - \_\_\_\_\_ DATE - \_\_\_\_\_

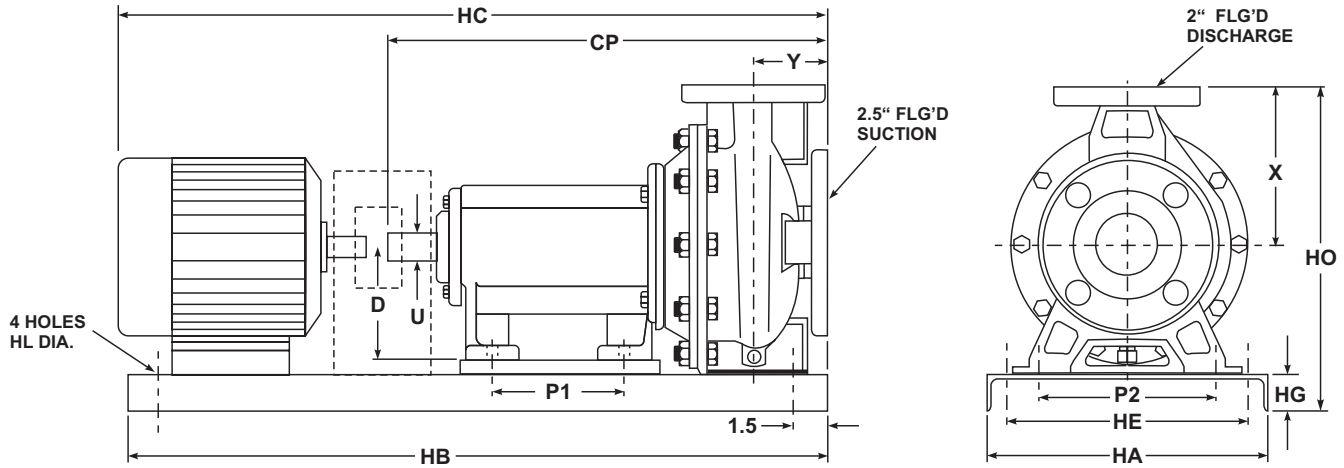

MOTOR FRAME	DIMENSIONS														WEIGHT (lbs)*		
	HA	HB	HL	HC*	HO	HG	HE	CP	P1	P2	D**	U	X	Y	PUMP	MOTOR	ASS'Y
56	10	35	0.62	33.0	14.19	2.62	7.0	22.0	5.75	5.62	5.25	1.25	6.31	3.94	90	30	165
143T	10	35	0.62	34.0	14.19	2.62	7.0	22.0	5.75	5.62	5.25	1.25	6.31	3.94	90	40	175
145T	10	35	0.62	34.0	14.19	2.62	7.0	22.0	5.75	5.62	5.25	1.25	6.31	3.94	90	40	175
182T	10	35	0.62	35.0	14.19	2.62	7.0	22.0	5.75	5.62	5.25	1.25	6.31	3.94	90	80	215
184T	10	35	0.62	35.0	14.19	2.62	7.0	22.0	5.75	5.62	5.25	1.25	6.31	3.94	90	80	215
213T	12	40	0.62	40.0	14.56	3.00	9.0	22.0	5.75	5.62	5.25	1.25	6.31	3.94	90	150	370
215T	12	40	0.62	40.0	14.56	3.00	9.0	22.0	5.75	5.62	5.25	1.25	6.31	3.94	90	150	370

NOTES - Not for construction purposes unless certified above.  
 - All dimensions in inches.  
 - Some dimensions may vary +/- 0.25 inches.  
 - \* Approximate only.  
 - \*\* Shaft centerline to underside of frame feet.









FF

# FLO FAB



**Manufacturer of Pumps, Tanks, Heat Exchangers & Accessories  
for HVAC Market After-Sales Parts and Services**

[www.flofab.com](http://www.flofab.com)

FLO-FAB INC  
LAKE WORTH,  
FLORIDA, USA

SEPTEMBER 2009