



# Design Guide

## VLT<sup>®</sup> AQUA Drive FC 202

0.25-90 kW





## Contents

<b>1 Introduction</b>	<b>8</b>
1.1 Purpose of the Design Guide	8
1.2 Organisation	8
1.3 Additional Resources	8
1.4 Abbreviations, Symbols and Conventions	9
1.5 Definitions	10
1.6 Document and Software Version	11
1.7 Approvals and Certifications	11
1.7.1 CE Mark	11
1.7.1.1 Low Voltage Directive	11
1.7.1.2 EMC Directive	11
1.7.1.3 Machinery Directive	11
1.7.1.4 ErP Directive	12
1.7.2 C-tick Compliance	12
1.7.3 UL Compliance	12
1.7.4 Marine Compliance	12
1.8 Safety	13
1.8.1 General Safety Principles	13
<b>2 Product Overview</b>	<b>15</b>
2.1 Introduction	15
2.2 Description of Operation	18
2.3 Sequence of Operation	20
2.3.1 Rectifier Section	20
2.3.2 Intermediate Section	20
2.3.3 Inverter Section	20
2.3.4 Brake Option	20
2.3.5 Load Sharing	20
2.4 Control Structures	20
2.4.1 Control Structure Open Loop	20
2.4.2 Control Structure Closed Loop	21
2.4.3 Local (Hand On) and Remote (Auto On) Control	22
2.4.4 Reference Handling	23
2.4.5 Feedback Handling	25
2.5 Automated Operational Functions	26
2.5.1 Short Circuit Protection	26
2.5.2 Overvoltage Protection	26
2.5.3 Missing Motor Phase Detection	27
2.5.4 Mains Phase Imbalance Detection	27

2.5.5 Switching on the Output	27
2.5.6 Overload Protection	27
2.5.7 Automatic Derating	27
2.5.8 Automatic Energy Optimisation	27
2.5.9 Automatic Switching Frequency Modulation	28
2.5.10 Automatic Derating for High Switching Frequency	28
2.5.11 Automatic Derating for Overtemperature	28
2.5.12 Auto Ramping	28
2.5.13 Current Limit Circuit	28
2.5.14 Power Fluctuation Performance	28
2.5.15 Motor Soft Start	28
2.5.16 Resonance Damping	28
2.5.17 Temperature-controlled Fans	28
2.5.18 EMC Compliance	28
2.5.19 Current Measurement on All Three Motor Phases	29
2.5.20 Galvanic Isolation of Control Terminals	29
2.6 Custom Application Functions	29
2.6.1 Automatic Motor Adaptation	29
2.6.2 Motor Thermal Protection	29
2.6.3 Mains Drop-out	30
2.6.4 Built-in PID Controllers	30
2.6.5 Automatic Restart	30
2.6.6 Flying Start	30
2.6.7 Full Torque at Reduced Speed	30
2.6.8 Frequency Bypass	30
2.6.9 Motor Preheat	30
2.6.10 Four Programmable Set-ups	30
2.6.11 Dynamic Braking	31
2.6.12 DC Braking	31
2.6.13 Sleep Mode	31
2.6.14 Run Permissive	31
2.6.15 Smart Logic Control (SLC)	31
2.6.16 STO Function	32
2.7 Fault, Warning and Alarm Functions	33
2.7.1 Operation at Overtemperature	33
2.7.2 High and Low Reference Warning	33
2.7.3 High and Low Feedback Warning	33
2.7.4 Phase Imbalance or Phase Loss	33
2.7.5 High Frequency Warning	33
2.7.6 Low Frequency Warning	33

2.7.7 High Current Warning	33
2.7.8 Low Current Warning	34
2.7.9 No Load/Broken Belt Warning	34
2.7.10 Lost Serial Interface	34
<b>2.8 User Interfaces and Programming</b>	<b>34</b>
2.8.1 Local Control Panel	34
2.8.2 PC Software	35
2.8.2.1 MCT 10 Set-up Software	35
2.8.2.2 VLT <sup>®</sup> Harmonics Calculation Software MCT 31	36
2.8.2.3 Harmonic Calculation Software (HCS)	36
<b>2.9 Maintenance</b>	<b>36</b>
2.9.1 Storage	36
<b>3 System Integration</b>	<b>37</b>
<b>3.1 Ambient Operating Conditions</b>	<b>37</b>
3.1.1 Humidity	37
3.1.2 Temperature	37
3.1.3 Cooling	38
3.1.4 Motor-generated Overvoltage	39
3.1.5 Acoustic Noise	39
3.1.6 Vibration and Shock	39
3.1.7 Aggressive Atmospheres	39
3.1.8 IP Rating Definitions	41
3.1.9 Radio Frequency Interference	41
3.1.10 PELV and Galvanic Isolation Compliance	42
3.1.11 Storage	42
<b>3.2 EMC, Harmonics and Earth Leakage Protection</b>	<b>42</b>
3.2.1 General Aspects of EMC Emissions	42
3.2.2 EMC Test Results	44
3.2.3 Emission Requirements	45
3.2.4 Immunity Requirements	45
3.2.5 Motor Insulation	46
3.2.6 Motor Bearing Currents	46
3.2.7 Harmonics	47
3.2.8 Earth Leakage Current	49
<b>3.3 Mains Integration</b>	<b>51</b>
3.3.1 Mains Configurations and EMC Effects	51
3.3.2 Low-frequency Mains Interference	51
3.3.3 Analysing Mains Interference	52
3.3.4 Options for Reducing Mains Interference	52

3.3.5 Radio Frequency Interference	52
3.3.6 Classification of the Operating Site	52
3.3.7 Use with Isolated Input Source	53
3.3.8 Power Factor Correction	53
3.3.9 Input Power Delay	53
3.3.10 Mains Transients	53
3.3.11 Operation with a Standby Generator	53
<b>3.4 Motor Integration</b>	<b>54</b>
3.4.1 Motor Selection Considerations	54
3.4.2 Sine-wave and dU/dt Filters	54
3.4.3 Proper Motor Grounding	54
3.4.4 Motor Cables	54
3.4.5 Motor Cable Shielding	55
3.4.6 Connection of Multiple Motors	55
3.4.7 Control Wire Isolation	57
3.4.8 Motor Thermal Protection	57
3.4.9 Output Contactor	58
3.4.10 Brake Functions	58
3.4.11 Dynamic Braking	58
3.4.12 Brake Resistor Calculation	58
3.4.13 Brake Resistor Cabling	59
3.4.14 Brake Resistor and Brake IGBT	59
3.4.15 Energy Efficiency	59
<b>3.5 Additional Inputs and Outputs</b>	<b>61</b>
3.5.1 Wiring Schematic	61
3.5.2 Relay Connections	62
3.5.3 EMC-compliant Electrical Connection	63
<b>3.6 Mechanical Planning</b>	<b>64</b>
3.6.1 Clearance	64
3.6.2 Wall Mounting	65
3.6.3 Access	65
<b>3.7 Options and Accessories</b>	<b>65</b>
3.7.1 Communication Options	69
3.7.2 Input/Output, Feedback and Safety Options	69
3.7.3 Cascade Control Options	69
3.7.4 Brake Resistors	70
3.7.5 Sine-wave Filters	70
3.7.6 dU/dt Filters	71
3.7.7 Common-mode Filters	71
3.7.8 Harmonic Filters	71

3.7.9 IP21/NEMA Type 1 Enclosure Kit	72
3.7.10 Remote Mounting Kit for LCP	74
3.7.11 Mounting Bracket for Enclosure Sizes A5, B1, B2, C1 and C2	75
<b>3.8 Serial Interface RS485</b>	<b>76</b>
3.8.1 Overview	76
3.8.2 Network Connection	77
3.8.3 RS485 Bus Termination	77
3.8.4 EMC Precautions	77
3.8.5 FC Protocol Overview	78
3.8.6 Network Configuration	78
3.8.7 FC Protocol Message Framing Structure	78
3.8.8 FC Protocol Examples	82
3.8.9 Modbus RTU Protocol	83
3.8.10 Modbus RTU Message Framing Structure	84
3.8.11 Access to Parameters	87
3.8.12 FC Drive Control Profile	88
<b>3.9 System Design Checklist</b>	<b>94</b>
<b>4 Application Examples</b>	<b>96</b>
4.1 Application Feature Overview	96
4.2 Selected Application Features	96
4.2.1 SmartStart	96
4.2.2 Quick Menu Water and Pumps	97
4.2.3 29-1* Deragging Function	97
4.2.4 Pre/post Lube	98
4.2.5 29-5* Flow Confirmation	99
4.3 Application Set-up Examples	100
4.3.1 Submersible Pump Application	102
4.3.2 BASIC Cascade Controller	103
4.3.3 Pump Staging with Lead Pump Alternation	104
4.3.4 System Status and Operation	104
4.3.5 Cascade Controller Wiring Diagram	105
4.3.6 Fixed Variable Speed Pump Wiring Diagram	106
4.3.7 Lead Pump Alternation Wiring Diagram	106
<b>5 Special Conditions</b>	<b>110</b>
5.1 Manual Derating	110
5.2 Derating for Long Motor Cables or Cables with Larger Cross-Section	111
5.3 Derating for Ambient Temperature	111
<b>6 Typecode and Selection</b>	<b>115</b>

6.1 Ordering	115
6.1.1 Type Code	115
6.1.2 Software Language	117
6.2 Options, Accessories, and Spare Parts	117
6.2.1 Options and Accessories	117
6.2.2 Spare Parts	119
6.2.3 Accessory Bags	119
6.2.4 Brake Resistor Selection	120
6.2.5 Recommended Brake Resistors	121
6.2.6 Alternative Brake Resistors, T2 and T4	128
6.2.7 Harmonic Filters	129
6.2.8 Sine-Wave Filters	131
6.2.9 dU/dt Filters	133
6.2.10 Common Mode Filters	134
<b>7 Specifications</b>	<b>135</b>
7.1 Electrical Data	135
7.1.1 Mains Supply 1x200–240 V AC	135
7.1.2 Mains Supply 3x200–240 V AC	136
7.1.3 Mains Supply 1x380–480 V AC	138
7.1.4 Mains Supply 3x380–480 V AC	139
7.1.5 Mains Supply 3x525–600 V AC	143
7.1.6 Mains Supply 3x525–690 V AC	147
7.2 Mains Supply	149
7.3 Motor Output and Motor Data	150
7.4 Ambient Conditions	151
7.5 Cable Specifications	151
7.6 Control Input/Output and Control Data	152
7.7 Fuses and Circuit Breakers	155
7.8 Power Ratings, Weight and Dimensions	163
7.9 dU/dt Testing	164
7.10 Acoustic Noise Ratings	166
7.11 Selected Options	167
7.11.1 VLT <sup>®</sup> General Purpose I/O Module MCB 101	167
7.11.2 VLT <sup>®</sup> Relay Card MCB 105	167
7.11.3 VLT <sup>®</sup> PTC Thermistor Card MCB 112	169
7.11.4 VLT <sup>®</sup> Extended Relay Card MCB 113	171
7.11.5 VLT <sup>®</sup> Sensor Input Option MCB 114	172
7.11.6 VLT <sup>®</sup> Extended Cascade Controller MCO 101	173
7.11.7 VLT <sup>®</sup> Advanced Cascade Controller MCO 102	175



<b>8 Appendix - Selected Drawings</b>	177
8.1 Mains Connection Drawings (3-phases)	177
8.2 Motor Connection Drawings	180
8.3 Relay Terminal Drawings	182
8.4 Cable Entry Holes	183
<b>Index</b>	188

# 1 Introduction

## 1.1 Purpose of the Design Guide

This design guide for Danfoss VLT® AQUA Drive frequency converters is intended for:

- Project and systems engineers
- Design consultants
- Application and product specialists

The design guide provides technical information to understand the capabilities of the frequency converter for integration into motor control and monitoring systems.

The purpose of the design guide is to provide design considerations and planning data for integration of the frequency converter into a system. The design guide caters for selection of frequency converters and options for a diversity of applications and installations.

Reviewing the detailed product information in the design stage enables developing a well-conceived system with optimal functionality and efficiency.

VLT® is a registered trademark.

## 1.2 Organisation

*Chapter 1 Introduction:* The general purpose of the design guide and compliance with international directives.

*Chapter 2 Product Overview:* The internal structure and functionality of the frequency converter and operational features.

*Chapter 3 System Integration:* Environmental conditions; EMC, harmonics and earth leakage; mains input; motors and motor connections; other connections; mechanical planning; and descriptions of options and accessories available.

*Chapter 4 Application Examples:* Samples of product applications and guidelines for use.

*Chapter 5 Special Conditions:* Details on unusual operational environments.

*Chapter 6 Typecode and Selection:* Procedures for ordering equipment and options to meet the intended use of the system.

*Chapter 7 Specifications:* A compilation of technical data in table and graphics format.

*Chapter 8 Appendix - Selected Drawings:* A compilation of graphics illustrating mains and motor connections, relay terminals, and cable entries.

## 1.3 Additional Resources

Resources available to understand advanced frequency converter operation, programming, and directives compliance:

- The *VLT® AQUA Drive FC 202 Operating Instructions* (referenced as *Operating Instructions* in this manual) provide detailed information for the installation and start up of the frequency converter.
- The *VLT® AQUA Drive FC 202 Design Guide* provides information required for design and planning for integration of the frequency converter into a system.
- The *VLT® AQUA Drive FC 202 Programming Guide* (referenced as *Programming Guide* in this manual) provides greater detail about how to work with parameters and many application examples.
- The *VLT® Safe Torque Off Operating Instructions* describe how to use Danfoss frequency converters in functional safety applications. This manual is supplied with the frequency converter when the STO option is present.
- The *VLT® Brake Resistor Design Guide* explains optimal brake resistor selection.

Supplemental publications and manuals are available for download from [danfoss.com/Product/Literature/Technical+Documentation.htm](http://danfoss.com/Product/Literature/Technical+Documentation.htm).

### **NOTICE**

**Optional equipment is available that may change some of the information described in these publications. Be sure to see the instructions supplied with the options for specific requirements.**

Contact a Danfoss supplier or visit [www.danfoss.com](http://www.danfoss.com) for additional information.

### 1.4 Abbreviations, Symbols and Conventions

60° AVM	60° Asynchronous vector modulation
A	Ampere/AMP
AC	Alternating current
AD	Air discharge
AEO	Automatic energy optimisation
AI	Analog input
AMA	Automatic motor adaptation
AWG	American wire gauge
°C	Degrees celsius
CD	Contant discharge
CM	Common mode
CT	Constant torque
DC	Direct current
DI	Digital input
DM	Differential mode
D-TYPE	Drive dependent
EMC	Electromagnetic compatibility
EMF	Electromotive force
ETR	Electronic thermal relay
f <sub>JOG</sub>	Motor frequency when jog function is activated.
f <sub>M</sub>	Motor frequency
f <sub>MAX</sub>	The maximum output frequency the frequency converter applies on its output.
f <sub>MIN</sub>	The minimum motor frequency from frequency converter
f <sub>M,N</sub>	Nominal motor frequency
FC	Frequency converter
g	Gramme
Hiperface®	Hiperface® is a registered trademark by Stegmann
hp	Horsepower
HTL	HTL encoder (10–30 V) pulses - High-voltage transistor logic
Hz	Hertz
I <sub>INV</sub>	Rated inverter output current
I <sub>LIM</sub>	Current limit
I <sub>M,N</sub>	Nominal motor current
I <sub>VLT,MAX</sub>	The maximum output current
I <sub>VLT,N</sub>	The rated output current supplied by the frequency converter
kHz	Kilohertz
LCP	Local control panel
lsb	Least significant bit
m	Meter
mA	Milliampere
MCM	Mille circular mil
MCT	Motion control tool
mH	Inductance in milli Henry
min	Minute
ms	Millisecond
msb	Most significant bit

η <sub>VLT</sub>	Efficiency of the frequency converter defined as ratio between power output and power input.
nF	Capacitance in nano Farad
NLCP	Numerical local control panel
Nm	Newton meter
n <sub>s</sub>	Synchronous motor speed
Online/Offline Parameters	Changes to online parameters are activated immediately after the data value is changed.
P <sub>br,cont.</sub>	Rated power of the brake resistor (average power during continuous braking).
PCB	Printed circuit board
PCD	Process data
PELV	Protective extra low voltage
P <sub>m</sub>	Frequency converter nominal output power as high overload (HO).
P <sub>M,N</sub>	Nominal motor power
PM motor	Permanent magnet motor
Process PID	The PID regulator maintains the desired speed, pressure, temperature, etc.
R <sub>br,nom</sub>	The nominal resistor value that ensures a brake power on motor shaft of 150/160% for 1 minute
RCD	Residual current device
Regen	Regenerative terminals
R <sub>min</sub>	Minimum permissible brake resistor value by frequency converter
RMS	Root mean square
RPM	Revolutions per minute
R <sub>rec</sub>	Recommended brake resistor resistance of Danfoss brake resistors
s	Second
SFAVM	Stator flux-oriented asynchronous vector modulation
STW	Status word
SMPS	Switch mode power supply
THD	Total harmonic distortion
T <sub>LIM</sub>	Torque limit
TTL	TTL encoder (5 V) pulses - transistor transistor logic
U <sub>M,N</sub>	Nominal motor voltage
V	Volts
VT	Variable torque
VVC+	Voltage vector control

Table 1.1 Abbreviations

**Conventions**

Numbered lists indicate procedures.

Bullet lists indicate other information and description of illustrations.

Italicised text indicates:

- Cross reference
- Link
- Footnote
- Parameter name, parameter group name, parameter option

All dimensions are in mm (inch).

\* indicates a default setting of a parameter.

The following symbols are used in this document:

**⚠ WARNING**

Indicates a potentially hazardous situation that could result in death or serious injury.

**⚠ CAUTION**

Indicates a potentially hazardous situation that could result in minor or moderate injury. It can also be used to alert against unsafe practices.

**NOTICE**

Indicates important information, including situations that can result in damage to equipment or property.

**1.5 Definitions****Brake resistor**

The brake resistor is a module capable of absorbing the brake power generated in regenerative braking. This regenerative braking power increases the intermediate circuit voltage and a brake chopper ensures that the power is transmitted to the brake resistor.

**Coast**

The motor shaft is in free mode. No torque on the motor.

**CT characteristics**

Constant torque characteristics used for all applications such as conveyor belts, displacement pumps and cranes.

**Initialising**

If initialising is carried out (*14-22 Operation Mode*), the frequency converter returns to the default setting.

**Intermittent duty cycle**

An intermittent duty rating refers to a sequence of duty cycles. Each cycle consists of an on-load and an off-load period. The operation can be either periodic duty or non-periodic duty.

**Power factor**

The true power factor ( $\lambda$ ) takes all the harmonics into consideration and is always smaller than the power factor ( $\cos\varphi$ ) that only considers the 1st harmonics of current and voltage.

$$\cos\varphi = \frac{P [\text{kW}]}{P [\text{kVA}]} = \frac{U\lambda \times I\lambda \times \cos\varphi}{U\lambda \times I\lambda}$$

$\cos\varphi$  is also known as displacement power factor.

Both  $\lambda$  and  $\cos\varphi$  are stated for Danfoss VLT® frequency converters in *chapter 7.2 Mains Supply*.

The power factor indicates to which extent the frequency converter imposes a load on the mains supply.

The lower the power factor, the higher the  $I_{\text{RMS}}$  for the same kW performance.

In addition, a high power factor indicates that the harmonic currents are low.

All Danfoss frequency converters have built-in DC coils in the DC link to have a high power factor and reduce the THD on the main supply.

**Set-up**

Save parameter settings in 4 set-ups. Change between the 4 parameter set-ups and edit 1 set-up while another set-up is active.

**Slip compensation**

The frequency converter compensates for the motor slip by giving the frequency a supplement that follows the measured motor load, keeping the motor speed almost constant.

**Smart logic Control (SLC)**

The SLC is a sequence of user-defined actions executed when the associated user-defined events are evaluated as true by the SLC. (Parameter group *13-\*\* Smart Logic*).

**FC Standard bus**

Includes RS485 bus with FC protocol or MC protocol. See *8-30 Protocol*.

**Thermistor**

A temperature-dependent resistor placed where the temperature is to be monitored (frequency converter or motor).

**Trip**

A state entered in fault situations, such as when the frequency converter is subject to an overtemperature or when it protects the motor, process or mechanism. Restart is prevented until the cause of the fault has disappeared and the trip state is cancelled. Cancel the trip state by:

- activating reset or
- programming the frequency converter to reset automatically

Do not use trip for personal safety.

**Trip locked**

A state entered in fault situations when the frequency converter is protecting itself and requires physical intervention, for example if the frequency converter is

subject to a short circuit on the output. A locked trip can only be cancelled by cutting off mains, removing the cause of the fault, and reconnecting the frequency converter. Restart is prevented until the trip state is cancelled by activating reset or, in some cases, by being programmed to reset automatically. Do not use trip may for personal safety.

**VT characteristics**

Variable torque characteristics for pumps and fans.

**1.6 Document and Software Version**

This manual is regularly reviewed and updated. All suggestions for improvement are welcome.

Table 1.2 shows the document version and the corresponding software version.

Edition	Remarks	Software version
MG20N6xx	Replaces MG20N5xx	2.20 and later

Table 1.2 Document and Software Version

**1.7 Approvals and Certifications**

Frequency converters are designed in compliance with the directives described in this section.

For more information on approvals and certificates, go to the download area at <http://www.danfoss.com/BusinessAreas/DrivesSolutions/Documentations/>.

**1.7.1 CE Mark**



Illustration 1.1 CE

The CE mark (Communauté Européenne) indicates that the product manufacturer conforms to all applicable EU directives. The EU directives applicable to the design and manufacture of frequency converters are listed in Table 1.3.

**NOTICE**

The CE mark does not regulate the quality of the product. Technical specifications cannot be deduced from the CE mark.

**NOTICE**

Frequency converters with an integrated safety function must comply with the machinery directive.

EU directive	Version
Low voltage directive	2006/95/EC
EMC directive	2004/108/EC
Machinery directive <sup>1)</sup>	2006/42/EC
ErP directive	2009/125/EC
ATEX directive	94/9/EC
RoHS directive	2002/95/EC

Table 1.3 EU Directives Applicable to Frequency Converters

<sup>1)</sup> Machinery directive conformance is only required for frequency converters with an integrated safety function.

Declarations of conformity are available on request.

**1.7.1.1 Low Voltage Directive**

The low voltage directive applies to all electrical equipment in the 50–1000 V AC and the 75–1600 V DC voltage ranges.

The aim of the directive is to ensure personal safety and avoid property damage, when operating electrical equipment that is installed and maintained correctly, in its intended application.

**1.7.1.2 EMC Directive**

The purpose of the EMC (electromagnetic compatibility) directive is to reduce electromagnetic interference and enhance immunity of electrical equipment and installations. The basic protection requirement of the EMC Directive 2004/108/EC states that devices that generate electromagnetic interference (EMI), or whose operation could be affected by EMI, must be designed to limit the generation of electromagnetic interference and shall have a suitable degree of immunity to EMI when properly installed, maintained, and used as intended.

Electrical equipment devices used alone or as part of a system must bear the CE mark. Systems do not require the CE mark, but must comply with the basic protection requirements of the EMC directive.

**1.7.1.3 Machinery Directive**

The aim of the machinery directive is to ensure personal safety and avoid property damage, for mechanical equipment used in its intended application. The machinery directive applies to a machine consisting of an aggregate of interconnected components or devices of which at least one is capable of mechanical movement.

Frequency converters with an integrated safety function must comply with the machinery directive. Frequency converters without safety function do not fall under the machinery directive. If a frequency converter is integrated into a machinery system, Danfoss can provide information on safety aspects relating to the frequency converter.

When frequency converters are used in machines with at least one moving part, the machine manufacturer must provide a declaration stating compliance with all relevant statutes and safety measures.

### 1.7.1.4 ErP Directive

The ErP directive is the European Ecodesign Directive for energy-related products. The directive sets ecodesign requirements for energy-related products, including frequency converters. The aim of the directive is to increase energy efficiency and the level of protection of the environment, while at the same time increasing the security of the energy supply. Environmental impact of energy-related products includes energy consumption throughout the entire product life cycle.

### 1.7.2 C-tick Compliance



Illustration 1.2 C-Tick

The C-tick label indicates compliance with the applicable technical standards for Electromagnetic Compatibility (EMC), and is required for placing electrical and electronic devices on the market in Australia and New Zealand.

The C-tick regulatory is about conducted and radiated emission. For frequency converters, apply the emission limits specified in EN/IEC 61800-3.

A declaration of conformity can be provided on request.

### 1.7.3 UL Compliance

#### UL Listed



Illustration 1.3 UL

### NOTICE

525-690 V frequency converters are not certified for UL.

The frequency converter complies with UL508C thermal memory retention requirements. For more information, refer to *chapter 2.6.2 Motor Thermal Protection*.

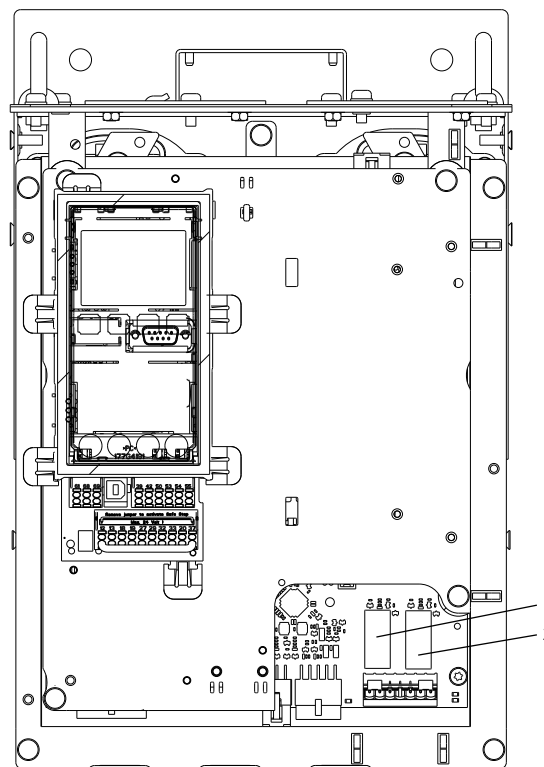
### 1.7.4 Marine Compliance

Units with ingress protection rating IP55 (NEMA 12) or higher prevent spark formation, and are classified as limited explosion risk electrical apparatus in accordance with the European Agreement concerning International Carriage of Dangerous Goods by Inland Waterways (ADN).

Go to [www.danfoss.com](http://www.danfoss.com) for additional marine approvals information.

For units with ingress protection rating IP20/Chassis, IP21/ NEMA 1, or IP54, prevent risk of spark formation as follows:

- Do not install a mains switch
- Ensure that 14-50 RFI Filter is set to [1] On.
- Remove all relay plugs marked RELAY. See *Illustration 1.4*.
- Check which relay options are installed, if any. The only permitted relay option is VLT® Extended Relay Card MCB 113.



1308D832.10

1, 2	Relay plugs
------	-------------

Illustration 1.4 Location of Relay Plugs

Manufacturer declaration is available upon request.

## 1.8 Safety

### 1.8.1 General Safety Principles

Frequency converters contain high-voltage components and have the potential for fatal injury if handled improperly. Only trained technicians should install and operate the equipment. Do not attempt repair work without first removing power from the frequency converter and waiting the designated amount of time for stored electrical energy to dissipate.

Strict adherence to safety precautions and notices is mandatory for safe operation of the frequency converter.

### 1.8.2 Qualified Personnel

Correct and reliable transport, storage, installation, operation, and maintenance are required for the trouble-free and safe operation of the frequency converter. Only qualified personnel are allowed to install or operate this equipment.

Qualified personnel are defined as trained staff, who are authorised to install, commission, and maintain equipment, systems, and circuits in accordance with pertinent laws and regulations. Additionally, the qualified personnel must be familiar with the instructions and safety measures described in these operating instructions.

#### **⚠ WARNING**

##### **HIGH VOLTAGE**

Frequency converters contain high voltage when connected to AC mains input, DC power supply, or load sharing. Failure to perform installation, start-up, and maintenance by qualified personnel can result in death or serious injury.

- Installation, start-up, and maintenance must be performed by qualified personnel only.

#### **⚠ WARNING**

##### **UNINTENDED START**

When the frequency converter is connected to AC mains, DC power supply, or load sharing, the motor may start at any time. Unintended start during programming, service, or repair work can result in death, serious injury, or property damage. The motor can start via an external switch, a serial bus command, an input reference signal from the LCP, or after a cleared fault condition.

To prevent unintended motor start:

- Disconnect the frequency converter from the mains.
- Press [Off/Reset] on the LCP before programming parameters.
- The frequency converter, motor, and any driven equipment must be fully wired and assembled when the frequency converter is connected to AC mains, DC power supply, or load sharing.

#### **⚠ WARNING**

##### **DISCHARGE TIME**

The frequency converter contains DC-link capacitors, which can remain charged even when the frequency converter is not powered. Failure to wait the specified time after power has been removed before performing service or repair work can result in death or serious injury.

- Stop the motor.
- Disconnect the AC mains and remote DC-link power supplies, including battery back-ups, UPS, and DC-link connections to other frequency converters.
- Disconnect or lock any PM motor.
- Wait for the capacitors to discharge fully, before performing any service or repair work. The duration of waiting time is specified in *Table 1.4*.

Voltage [V]	Minimum waiting time (minutes)		
	4	7	15
200-240	0.25-3.7 kW	-	5.5-45 kW
380-480	0.37-7.5 kW	-	11-90 kW
525-600	0.75-7.5 kW	-	11-90 kW
525-690	-	1.1-7.5 kW	11-90 kW

High voltage may be present even when the warning LED indicator lights are off.

Table 1.4 Discharge Time

**⚠ WARNING****LEAKAGE CURRENT HAZARD**

Leakage currents exceed 3.5 mA. Failure to ground the frequency converter properly can result in death or serious injury.

- Ensure the correct grounding of the equipment by a certified electrical installer.

**⚠ WARNING****EQUIPMENT HAZARD**

Contact with rotating shafts and electrical equipment can result in death or serious injury.

- Ensure that only trained and qualified personnel perform installation, start up, and maintenance.
- Ensure that electrical work conforms to national and local electrical codes.
- Follow the procedures in this document.

**⚠ WARNING****UNINTENDED MOTOR ROTATION  
WINDMILLING**

Unintended rotation of permanent magnet motors creates voltage and can charge the unit, resulting in death, serious injury, or equipment damage.

- Ensure that permanent magnet motors are blocked to prevent unintended rotation.

**⚠ CAUTION****INTERNAL FAILURE HAZARD**

An internal failure in the frequency converter can result in serious injury, when the frequency converter is not properly closed.

- Ensure that all safety covers are in place and securely fastened before applying power.



## 2 Product Overview

### 2.1 Introduction

This chapter provides an overview of the frequency converter's primary assemblies and circuitry. It describes the internal electrical and signal processing functions. A description of the internal control structure is also included.

Also described are automated and optional frequency converter functions available for designing robust operating systems with sophisticated control and status reporting performance.

#### 2.1.1 Product Dedication to Water and Wastewater Applications

The VLT® AQUA Drive FC 202 is designed for water and wastewater applications. The integrated SmartStart wizard and the quick menu *Water and Pumps* guide the user through the commissioning process. The range of standard and optional features includes:

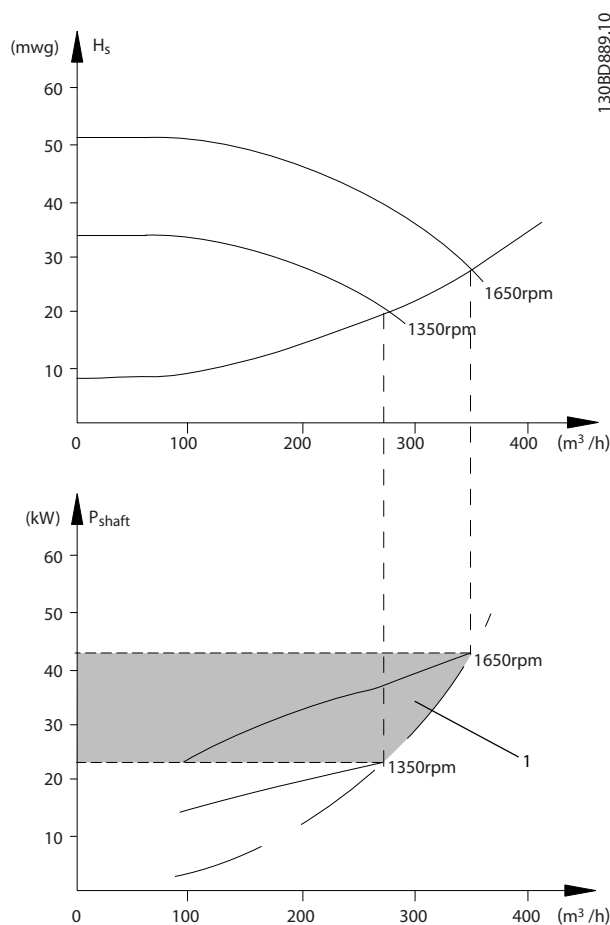
- Cascade control
- Dry-run detection
- End of curve detection
- Motor alternation
- Deragging
- Initial and final ramp
- Check valve ramp
- STO
- Low-flow detection
- Pre lube
- Flow confirmation
- Pipe fill mode
- Sleep mode
- Real-time clock
- Password protection
- Overload protection
- Smart logic control
- Minimum speed monitor
- Free programmable texts for information, warnings and alerts

### 2.1.2 Energy Savings

When comparing with alternative control systems and technologies, a frequency converter is the optimum energy control system for controlling fan and pump systems.

By using a frequency converter to control the flow, around 50% of energy savings can be achieved in typical applications, if the pump speed is reduced by 20%.

*Illustration 2.1* shows an example of the achievable energy reduction.



1	Energy saving
---	---------------

**Illustration 2.1 Example: Energy Saving**

### 2.1.3 Example of Energy Savings

As shown in *Illustration 2.2*, the flow is controlled by changing the pump speed, measured in RPM. By reducing the speed only 20% from the rated speed, the flow is also reduced by 20%. This is because the flow is directly proportional to the speed. The consumption of electricity, however, is reduced by up to almost 50%. If the system only needs to supply a flow that corresponds to 100% a few days in a year, while the average is below 80% of the rated flow for the remainder of the year, the amount of energy saved is even greater than 50%.

*Illustration 2.2* describes the dependence of flow, pressure and power consumption on pump speed in RPM for centrifugal pumps.

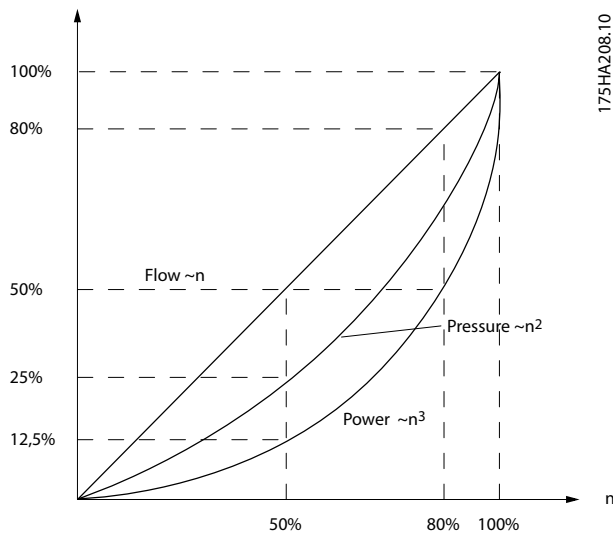


Illustration 2.2 Affinity Laws for Centrifugal Pumps

Flow:  $\frac{Q_1}{Q_2} = \frac{n_1}{n_2}$   
 Pressure:  $\frac{H_1}{H_2} = \left(\frac{n_1}{n_2}\right)^2$   
 Power:  $\frac{P_1}{P_2} = \left(\frac{n_1}{n_2}\right)^3$

Assuming an equal efficiency in the speed range.

Q=Flow	P=Power
Q <sub>1</sub> =Flow 1	P <sub>1</sub> =Power 1
Q <sub>2</sub> =Reduced flow	P <sub>2</sub> =Reduced power
H=Pressure	n=Speed regulation
H <sub>1</sub> =Pressure 1	n <sub>1</sub> =Speed 1
H <sub>2</sub> =Reduced pressure	n <sub>2</sub> =Reduced speed

Table 2.1 Affinity Laws

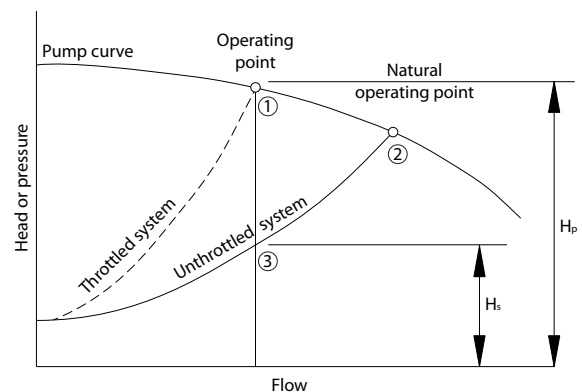
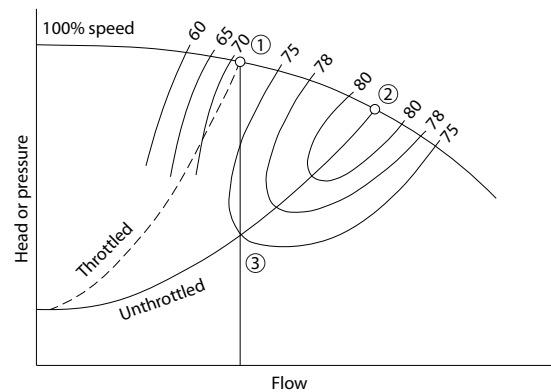
### 2.1.4 Valve Control versus Speed Control of Centrifugal Pumps

#### Valve control

As the demand for process requirements in water systems varies, the flow has to be adjusted accordingly. Frequently used methods for flow adaptation are throttling or recycling using valves.

A recycle valve that is opened too wide can cause the pump to run at the end of the pump curve, with a high flow rate at a low pump head. These conditions do not only cause a waste of energy due to the high speed of the pump, but can also lead to pump cavitation with resultant pump damage.

Throttling the flow with a valve, adds a pressure drop across the valve (HP-HS). This can be compared with accelerating and pulling the brake at the same time, in an attempt to reduce car speed. *Illustration 2.3* shows that throttling makes the system curve turn from point (2) on the pump curve to a point with significantly reduced efficiency (1).

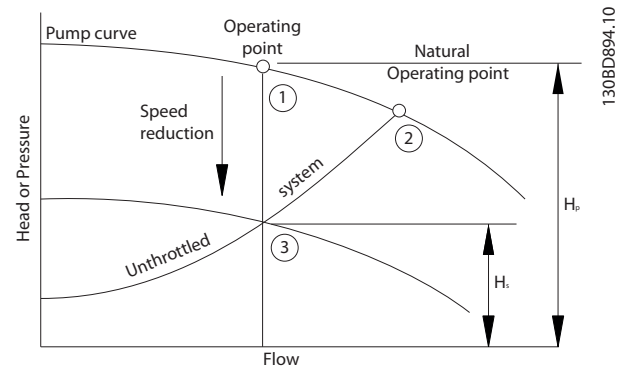


1	Operating point using a throttle valve
2	Natural operating point
3	Operating point using speed control

Illustration 2.3 Flow Reduction by Valve Control (Throttling)

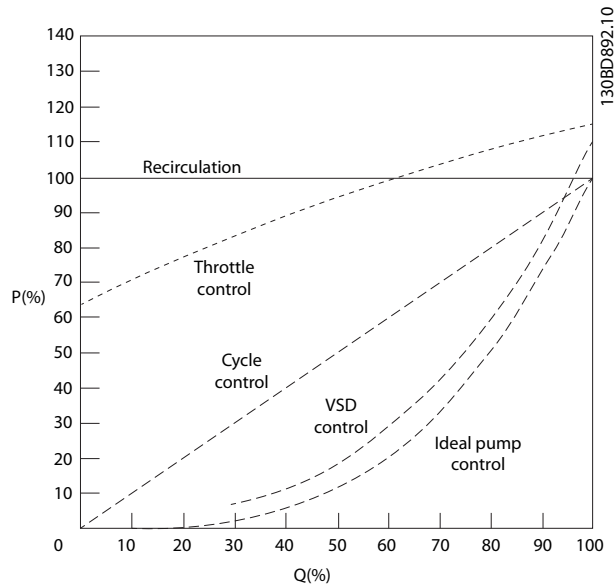
**Speed control**

The same flow can be adjusted by reducing the speed of the pump, as shown in *Illustration 2.4*. Reducing the speed moves the pump curve down. The point of operation is the new intersection point of the pump curve and the system curve (3). The energy savings can be calculated by applying the affinity laws as described in *chapter 2.1.3 Example of Energy Savings*.



1	Operating point using a throttle valve
2	Natural operating point
3	Operating point using speed control

**Illustration 2.4 Flow Reduction by Speed Control**

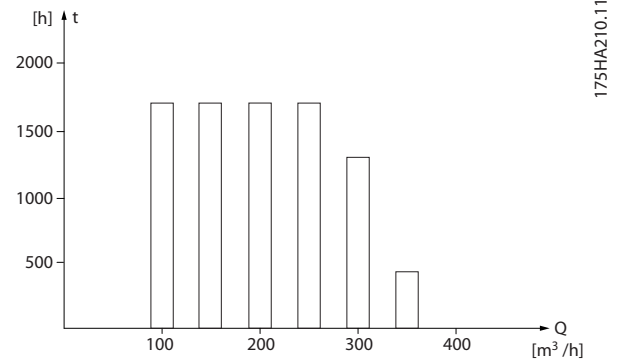


**Illustration 2.5 Comparative Flow Control Curves**

**2.1.5 Example with Varying Flow over 1 Year**

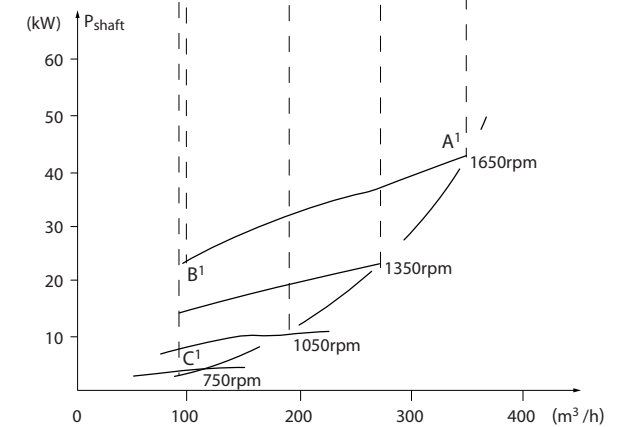
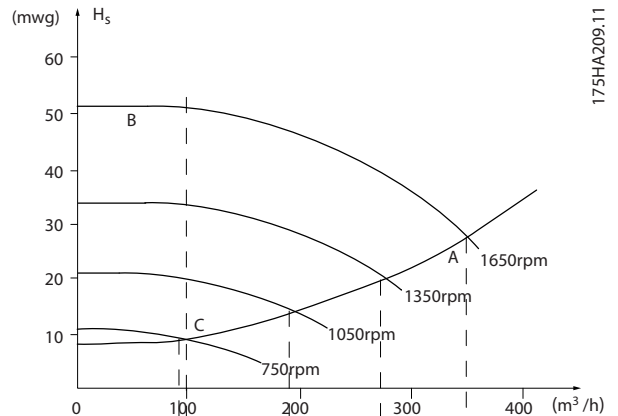
This example is calculated based on pump characteristics obtained from a pump datasheet, shown in *Illustration 2.7*.

The result obtained shows energy savings in excess of 50% at the given flow distribution over a year, see *Illustration 2.6*. The payback period depends on the price of electricity and the price of the frequency converter. In this example, payback is less than a year, when compared with valves and constant speed.



t [h]	Duration of flow. See also Table 2.2.
Q [m³/h]	Flowrate

**Illustration 2.6 Flow Distribution over 1 Year (Duration versus Flowrate )**



**Illustration 2.7 Energy Consumption at Different Speeds**

Flow rate	Distribution		Valve regulation		Frequency converter control	
	%	Duration	Power	Consumption	Power	Consumption
[m <sup>3</sup> /h]		[h]	[kW]	[kWh]	[kW]	[kWh]
350	5	438	42.5 <sup>1)</sup>	18.615	42.5 <sup>1)</sup>	18.615
300	15	1314	38.5	50.589	29.0	38.106
250	20	1752	35.0	61.320	18.5	32.412
200	20	1752	31.5	55.188	11.5	20.148
150	20	1752	28.0	49.056	6.5	11.388
100	20	1752	23.0 <sup>2)</sup>	40.296	3.5 <sup>3)</sup>	6.132
<b>Σ</b>	10	8760	–	275.064	–	26.801
	0					

Table 2.2 Result

1) Power reading at point A1

2) Power reading at point B1

3) Power reading at point C1

### 2.1.6 Improved Control

Using a frequency converter to control the flow or pressure of a system improves control.

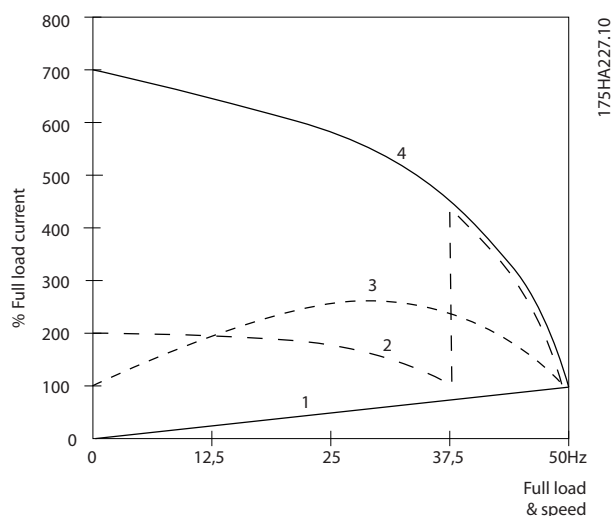
A frequency converter can vary the speed of the fan or pump, obtaining variable control of flow and pressure. Furthermore, a frequency converter can quickly adapt the speed of the fan or pump to new flow or pressure conditions in the system.

Obtain simple control of process (flow, level or pressure) utilising the built-in PI control.

### 2.1.7 Star/Delta Starter or Soft Starter

When large motors are started, it is necessary in many countries to use equipment that limits the start-up current. In more traditional systems, a star/delta starter or soft starter is widely used. Such motor starters are not required if a frequency converter is used.

As illustrated in *Illustration 2.8*, a frequency converter does not consume more than rated current.



1	VLT® AQUA Drive FC 202
2	Star/delta starter
3	Soft starter
4	Start directly on mains

Illustration 2.8 Start-up Current

## 2.2 Description of Operation

The frequency converter supplies a regulated amount of mains AC power to the motor to control its speed. The frequency converter supplies variable frequency and voltage to the motor.

The frequency converter is divided into 4 main modules:

- Rectifier
- Intermediate DC bus circuit
- Inverter
- Control and regulation

*Illustration 2.9* is a block diagram of the internal components of the frequency converter. See *Table 2.3* for their functions.

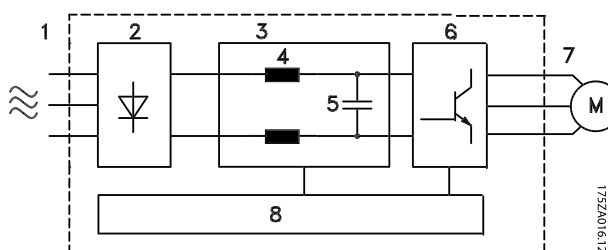


Illustration 2.9 Frequency Converter Block Diagram

Area	Title	Functions
1	Mains input	<ul style="list-style-type: none"> <li>3-phase AC mains power supply to the frequency converter.</li> </ul>
2	Rectifier	<ul style="list-style-type: none"> <li>The rectifier bridge converts the AC input to DC current to supply inverter power.</li> </ul>
3	DC bus	<ul style="list-style-type: none"> <li>Intermediate DC bus circuit handles the DC current.</li> </ul>
4	DC reactors	<ul style="list-style-type: none"> <li>Filter the intermediate DC circuit voltage.</li> <li>Provide mains transient protection.</li> <li>Reduce RMS current.</li> <li>Raise the power factor reflected back to the line.</li> <li>Reduce harmonics on the AC input.</li> </ul>
5	Capacitor bank	<ul style="list-style-type: none"> <li>Stores the DC power.</li> <li>Provides ride-through protection for short power losses.</li> </ul>
6	Inverter	<ul style="list-style-type: none"> <li>Converts the DC into a controlled PWM AC waveform for a controlled variable output to the motor.</li> </ul>
7	Output to motor	<ul style="list-style-type: none"> <li>Regulated 3-phase output power to the motor.</li> </ul>

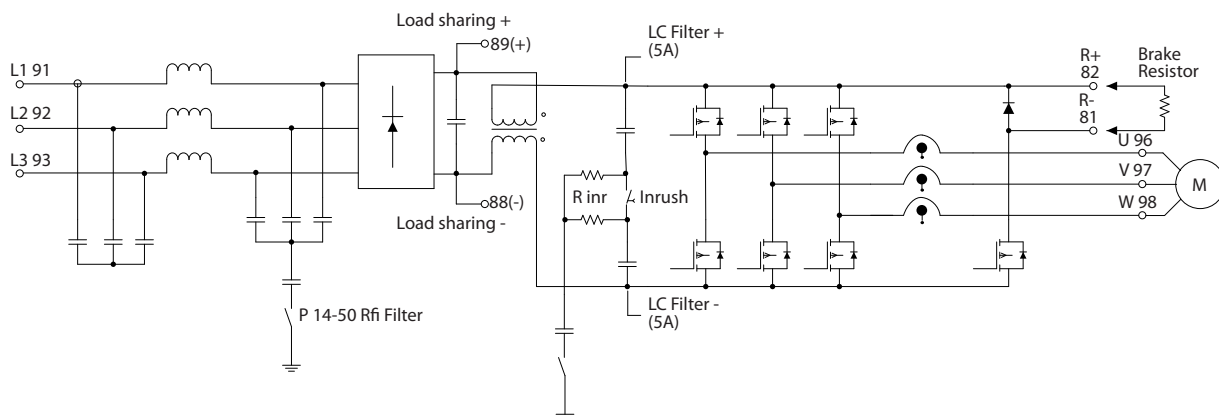
Area	Title	Functions
8	Control circuitry	<ul style="list-style-type: none"> <li>Input power, internal processing, output, and motor current are monitored to provide efficient operation and control.</li> <li>User interface and external commands are monitored and performed.</li> <li>Status output and control can be provided.</li> </ul>

Table 2.3 Legend to Illustration 2.9

The frequency converter rectifies AC voltage from mains into DC voltage, after which this DC voltage is converted into an AC current with a variable amplitude and frequency.

The frequency converter supplies the motor with variable voltage/current and frequency, which enables variable speed control of 3-phased, standard asynchronous motors and non-salient PM motors.

The frequency converter manages various motor control principles such as U/f special motor mode and VVC+. Short-circuit behavior of the frequency converter depends on the 3 current transducers in the motor phases.



130BA193.14

Illustration 2.10 Frequency Converter Structure

## 2.3 Sequence of Operation

### 2.3.1 Rectifier Section

When power is first applied to the frequency converter, it enters through the input terminals (L1, L2, and L3) and on to the disconnect and/or RFI filter option, depending on the unit's configuration.

### 2.3.2 Intermediate Section

Following the rectifier section, voltage passes to the intermediate section. This rectified voltage is smoothed by an sine-wave filter circuit consisting of the DC bus inductor and the DC bus capacitor bank.

The DC bus inductor provides series impedance to changing current. This aids the filtering process while reducing harmonic distortion to the input AC current waveform normally inherent in rectifier circuits.

### 2.3.3 Inverter Section

In the inverter section, once a run command and speed reference are present, the IGBTs begin switching to create the output waveform. This waveform, as generated by the Danfoss VVC<sup>+</sup> PWM principle at the control card, provides optimal performance and minimal losses in the motor.

### 2.3.4 Brake Option

For frequency converters equipped with the dynamic brake option, a brake IGBT along with terminals 81(R-) and 82(R+) are included for connecting an external brake resistor.

The function of the brake IGBT is to limit the voltage in the intermediate circuit, whenever the maximum voltage limit is exceeded. It does this by switching the externally mounted resistor across the DC bus to remove excess DC voltage present on the bus capacitors.

External brake resistor placement has the advantages of selecting the resistor based on application need, dissipating the energy outside of the control panel, and protecting the converter from overheating if the brake resistor is overloaded.

The brake IGBT gate signal originates on the control card and is delivered to the brake IGBT via the power card and gate drive card. Additionally, the power and control cards monitor the brake IGBT and brake resistor connection for short-circuits and overloads. For pre-fuse specifications, refer to *chapter 7.1 Electrical Data*. See also *chapter 7.7 Fuses and Circuit Breakers*.

### 2.3.5 Load Sharing

Units with the built-in load sharing option contain terminals (+) 89 DC and (-) 88 DC. Within the frequency converter, these terminals connect to the DC bus in front of the DC link reactor and bus capacitors.

For more information contact Danfoss.

The load-sharing terminals can connect in 2 different configurations.

1. In the first method, the terminals tie the DC-bus circuits of multiple frequency converters together. This allows a unit that is in a regenerative mode to share its excess bus voltage with another unit that is running a motor. Load sharing in this manner can reduce the need for external dynamic brake resistors, while also saving energy. The number of units that can be connected in this way is infinite, as long as each unit has the same voltage rating. In addition, depending on the size and number of units, it may be necessary to install DC reactors and DC fuses in the DC link connections, and AC reactors on the mains. Attempting such a configuration requires specific considerations. Contact Danfoss for assistance.
2. In the second method, the frequency converter is powered exclusively from a DC source. This requires:
  - 2a A DC source.
  - 2b A means to soft charge the DC bus at power-up.

Again, attempting such a configuration requires specific considerations. Contact Danfoss for assistance.

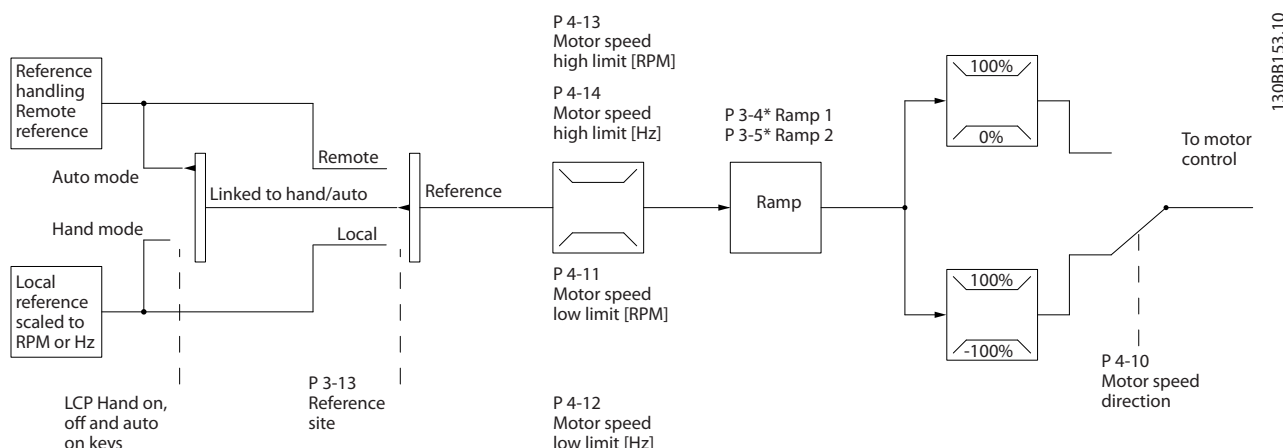
## 2.4 Control Structures

### 2.4.1 Control Structure Open Loop

When operating in open-loop mode, the frequency converter responds to input commands manually via the LCP keys or remotely via the analog/digital inputs or serial bus.

In the configuration shown in *Illustration 2.11*, the frequency converter operates in open-loop mode. It receives input from either the LCP (hand mode) or via a remote signal (auto mode). The signal (speed reference) is received and conditioned with programmed minimum and maximum motor speed limits (in RPM and Hz), ramp-up

and ramp-down times, and the direction of motor rotation. The reference is then passed on to control the motor.



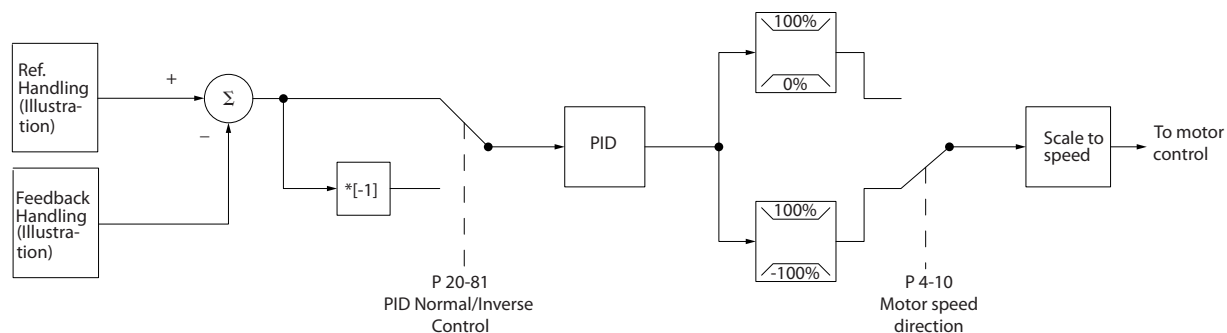
130BB153.10

Illustration 2.11 Open-loop Mode Block Diagram

### 2.4.2 Control Structure Closed Loop

In closed-loop mode, an internal PID controller allows the frequency converter to process system reference and feedback signals to act as an independent control unit. The converter can provide status and alarm messages, along

with many other programmable options, for external system monitoring while operating independently in closed loop.



130BA359.12

Illustration 2.12 Block Diagram of Closed-loop Controller

For example, consider a pump application in which the speed of a pump is controlled so that the static pressure in a pipe is constant (see *Illustration 2.12*). The frequency converter receives a feedback signal from a sensor in the system. It compares this feedback to a setpoint reference value and determines the error, if any, between these 2 signals. It then adjusts the speed of the motor to correct this error.

reduce the pressure. In a similar way, if the pipe pressure is lower than the setpoint reference, the frequency converter speeds up to increase the pressure provided by the pump.

While the default values for the frequency converter in closed loop often provide satisfactory performance, system control can often be optimised by tuning the PID parameters. *Auto tuning* is provided for this optimisation.

The desired static pressure setpoint is the reference signal to the frequency converter. A static pressure sensor measures the actual static pressure in the pipe and provides this information to the frequency converter as a feedback signal. If the feedback signal is greater than the setpoint reference, the frequency converter slows to

Other programmable features include:

- Inverse regulation - motor speed increases when a feedback signal is high.
- Start-up frequency - lets the system quickly reach an operating status before the PID controller takes over.
- Built-in lowpass filter - reduces feedback signal noise.

### 2.4.3 Local (Hand On) and Remote (Auto On) Control

The frequency converter can be operated manually via the LCP, or remotely via analog and digital inputs and serial bus.

#### Active reference and configuration mode

The active reference is either a local reference or a remote reference. Remote reference is the default setting.

- To use the local reference, perform configuration in manual mode, known as *Hand On* mode. To enable manual mode, adapt parameter settings in parameter group 0-4\* *LCP Keypad*. For more information, refer to the *programming guide*.
- To use the remote reference, perform configuration in *Auto On* mode, which is the default mode. In *Auto On* mode, it is possible to control the frequency converter via the digital inputs and various serial interfaces (RS485, USB, or an optional fieldbus).
- *Illustration 2.13* illustrates the configuration mode resulting from active reference selection, either local or remote.
- *Illustration 2.14* illustrates manual configuration mode for local reference.

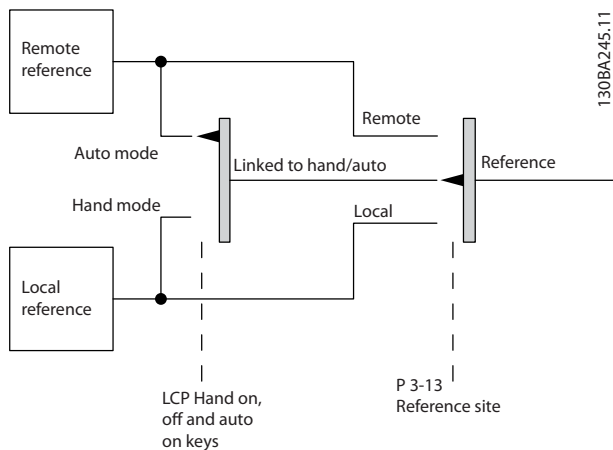


Illustration 2.13 Active Reference

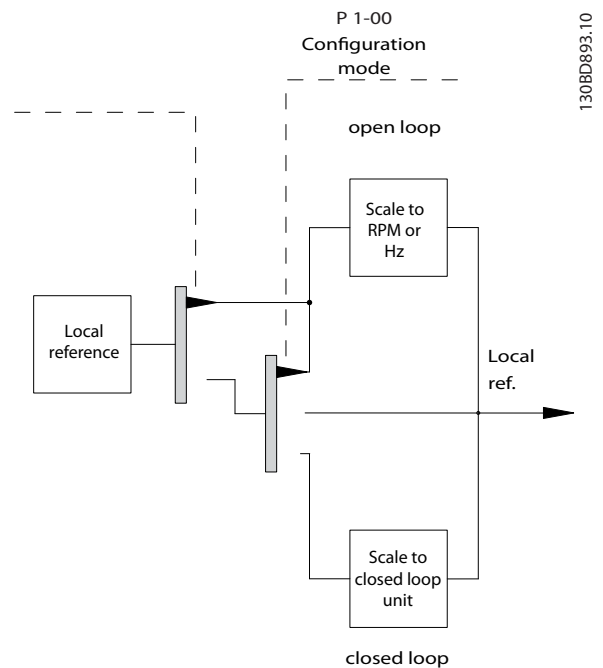


Illustration 2.14 Configuration Mode

#### Application control principle

Either the remote reference or the local reference is active at any time. Both cannot be active simultaneously. Set the application control principle (that is, open loop or closed loop) in 1-00 *Configuration Mode*, as shown in *Table 2.4*. When the local reference is active, set the application control principle in 1-05 *Local Mode Configuration*. Set the reference site in 3-13 *Reference Site*, as shown in *Table 2.4*.

For more information refer to the *Programming Guide*.

[Hand On] [Auto On] LCP Keys	Reference Site 3-13 <i>Reference Site</i>	Active Reference
Hand	Linked to Hand/Auto	Local
Hand⇒Off	Linked to Hand/Auto	Local
Auto	Linked to Hand/Auto	Remote
Auto ⇒Off	Linked to Hand/Auto	Remote
All keys	Local	Local
All keys	Remote	Remote

Table 2.4 Local and Remote Reference Configurations



## 2.4.4 Reference Handling

Reference handling is applicable in both open and closed loop operation.

### Internal and external references

Up to 8 internal preset references can be programmed into the frequency converter. The active internal preset reference can be selected externally through digital control inputs or the serial communications bus.

External references can also be supplied to the converter, most commonly through an analog control input. All reference sources and the bus reference are added to produce the total external reference. The external reference, the preset reference, the setpoint, or the sum of all 3 can be selected as the active reference. This reference can be scaled.

The scaled reference is calculated as follows:

$$\text{Reference} = X + X \times \left( \frac{Y}{100} \right)$$

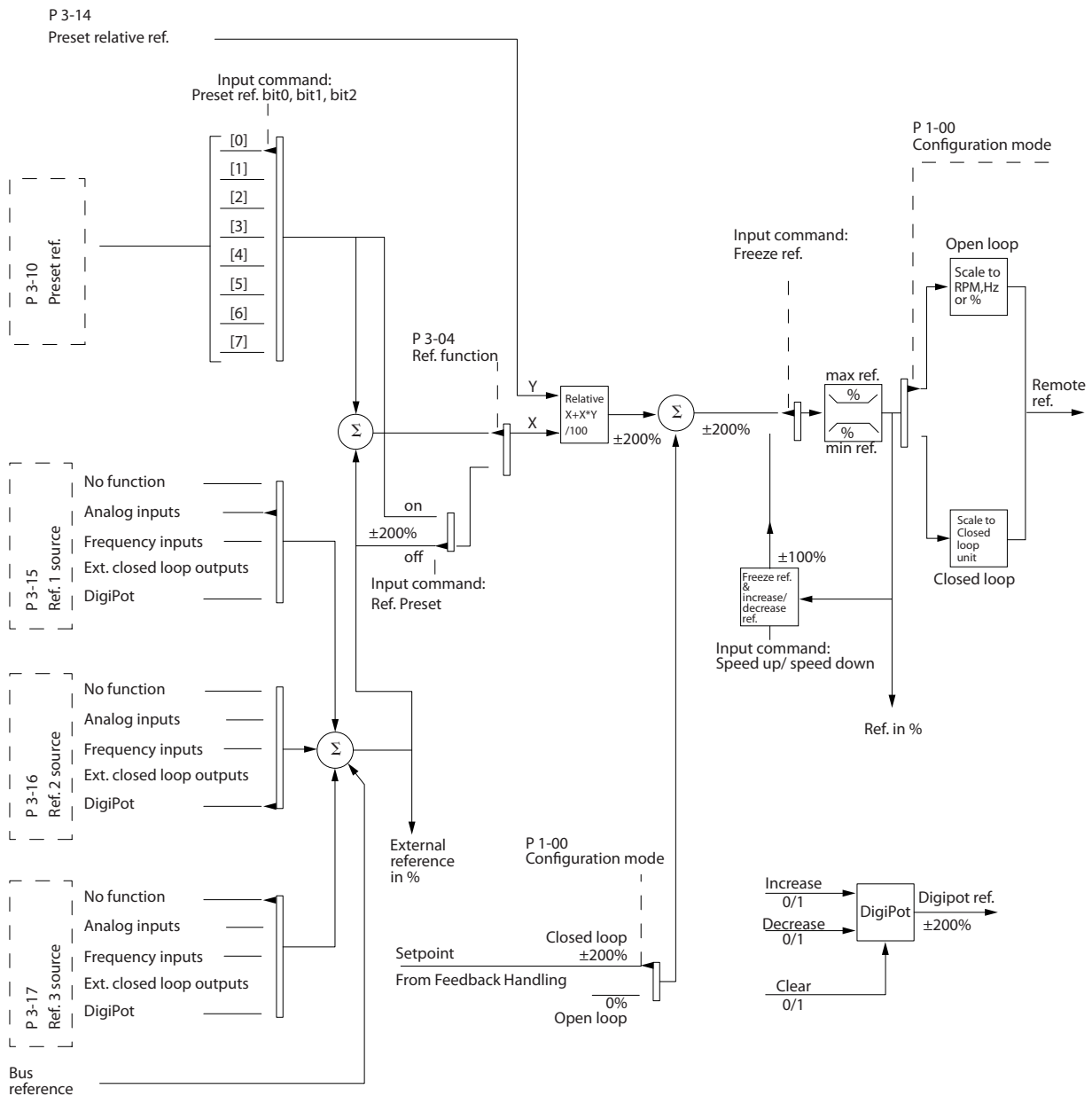
Where X is the external reference, the preset reference, or the sum of these and Y is 3-14 Preset Relative Reference in [%].

If Y, 3-14 Preset Relative Reference, is set to 0%, the scaling does not affect the reference.

### Remote reference

A remote reference is comprised of the following (see *Illustration 2.15*).

- Preset references
- External references (analog inputs, pulse frequency inputs, digital potentiometer inputs, and serial communication bus references)
- A preset relative reference
- A feedback controlled setpoint



130BA357.12

Illustration 2.15 Block Diagram Showing Remote Reference Handling

### 2.4.5 Feedback Handling

Feedback handling can be configured to work with applications requiring advanced control, such as multiple setpoints and multiple types of feedback (see *Illustration 2.16*). Three types of control are common:

#### Single zone, single setpoint

This is a basic feedback configuration. Setpoint 1 is added to any other reference (if any) and the feedback signal is selected.

#### Multi zone, single setpoint

This uses 2 or 3 feedback sensors but only one setpoint. The feedback can be added, subtracted, or averaged. In addition, the maximum or minimum value can be used. Setpoint 1 is used exclusively in this configuration.

#### Multi zone, setpoint/feedback

The setpoint/feedback pair with the largest difference controls the speed of the frequency converter. The maximum attempts to keep all zones at or below their respective setpoints, while minimum attempts to keep all zones at or above their respective setpoints.

#### Example

A 2-zone, 2-setpoint application. Zone 1 setpoint is 15 bar and the feedback is 5.5 bar. Zone 2 setpoint is 4.4 bar and the feedback is 4.6 bar. If maximum is selected, the zone 1 setpoint and feedback are sent to the PID controller, since it has the smaller difference (feedback is higher than setpoint, resulting in a negative difference). If minimum is selected, the zone 2 setpoint and feedback is sent to the PID controller, since it has the larger difference (feedback is lower than setpoint, resulting in a positive difference).

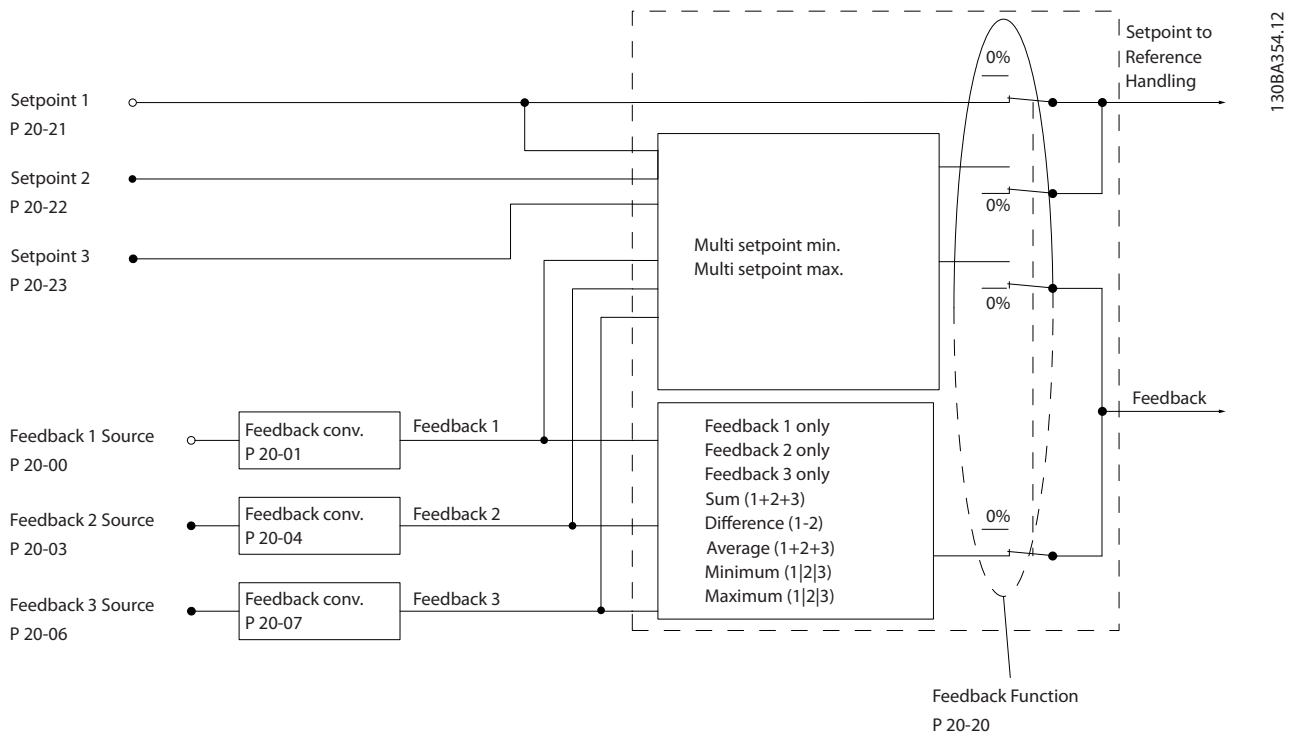


Illustration 2.16 Block Diagram of Feedback Signal Processing

### Feedback conversion

In some applications, it is useful to convert the feedback signal. One example is using a pressure signal to provide flow feedback. Since the square root of pressure is proportional to flow, the square root of the pressure signal yields a value proportional to the flow. This is shown in *Illustration 2.17*.

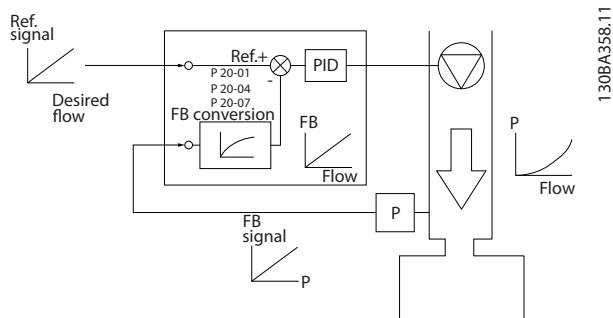


Illustration 2.17 Feedback Conversion

## 2.5 Automated Operational Functions

Automated operational features are active as soon as the frequency converter is operating. Most of them require no programming or set-up. Understanding that these features are present can optimise a system design and possibly avoid introducing redundant components or functionality.

For details of any set-up required, in particular motor parameters, refer to the *Programming Guide*.

The frequency converter has a range of built-in protection functions to protect itself and the motor it is running.

### 2.5.1 Short Circuit Protection

#### Motor (phase-phase)

The frequency converter is protected against short circuits on the motor side by current measurement in each of the 3 motor phases or in the DC link. A short circuit between 2 output phases causes an overcurrent in the inverter. The inverter is turned off when the short-circuit current exceeds the permitted value (Alarm 16 Trip Lock).

#### Mains side

A frequency converter that works correctly limits the current it can draw from the supply. Still, it is recommended to use fuses and/or circuit breakers on the supply side as protection in case of component breakdown inside the frequency converter (first fault). See *chapter 7.7 Fuses and Circuit Breakers* for more information.

### NOTICE

To ensure compliance with IEC 60364 for CE or NEC 2009 for UL, it is mandatory to use fuses and/or circuit breakers.

### Brake resistor

The frequency converter is protected from a short-circuit in the brake resistor.

### Load sharing

To protect the DC bus against short-circuits and the frequency converters from overload, install DC fuses in series with the load sharing terminals of all connected units. See *chapter 2.3.5 Load Sharing* for more information.

## 2.5.2 Overvoltage Protection

### Motor-generated overvoltage

The voltage in the intermediate circuit is increased when the motor acts as a generator. This occurs in following cases:

- The load drives the motor (at constant output frequency from the frequency converter), for example, the load generates energy.
- During deceleration (ramp-down) if the moment of inertia is high, the friction is low and the ramp-down time is too short for the energy to be dissipated as a loss in the frequency converter, the motor, and the installation.
- Incorrect slip compensation setting may cause higher DC-link voltage.
- Back EMF from PM motor operation. If coasted at high RPM, the PM motor back EMF may potentially exceed the maximum voltage tolerance of the frequency converter and cause damage. To help prevent this, the value of *4-19 Max Output Frequency* is automatically limited via an internal calculation based on the value of *1-40 Back EMF at 1000 RPM*, *1-25 Motor Nominal Speed*, and *1-39 Motor Poles*.

### NOTICE

To avoid motor overspeeding (for example, due to excessive windmilling effects or uncontrolled water flow), equip the frequency converter with a brake resistor.

The overvoltage can be handled by either using a brake function (*2-10 Brake Function*) or using overvoltage control (*2-17 Over-voltage Control*).

### Overvoltage control (OVC)

OVC reduces the risk of the frequency converter tripping due to an overvoltage on the DC-link. This is managed by automatically extending the ramp-down time.

**NOTICE**

OVC can be activated for PM motors (PM VVC+).

**Brake functions**

Connect a brake resistor for dissipation of surplus brake energy. Connecting a brake resistor prevents excessively high DC-link voltage during braking.

An AC brake is an alternative to improve braking without using a brake resistor. This function controls an overmagnetisation of the motor when running as a generator creating extra energy. This function can improve the OVC. Increasing the electrical losses in the motor allows the OVC function to increase the braking torque without exceeding the overvoltage limit.

**NOTICE**

AC braking is not as effective as dynamic braking with a resistor.

### 2.5.3 Missing Motor Phase Detection

The *missing motor phase* function (4-58 *Missing Motor Phase Function*) is enabled by default to avoid motor damage in the case that a motor phase is missing. The default setting is 1000 ms, but it can be adjusted for a faster detection.

### 2.5.4 Mains Phase Imbalance Detection

Operation under severe mains imbalance conditions reduces the lifetime of the motor. Conditions are considered severe if the motor is operated continuously near nominal load. The default setting trips the frequency converter in case of mains imbalance (14-12 *Function at Mains Imbalance*).

### 2.5.5 Switching on the Output

Adding a switch to the output between the motor and the frequency converter is permitted. Fault messages may appear. Enable flying start to catch a spinning motor.

### 2.5.6 Overload Protection

**Torque limit**

The torque limit feature protects the motor against overload, independent of the speed. Torque limit is controlled in 4-16 *Torque Limit Motor Mode* or 4-17 *Torque Limit Generator Mode* and the time before the torque limit warning trips is controlled in 14-25 *Trip Delay at Torque Limit*.

**Current limit**

The current limit is controlled in 4-18 *Current Limit*.

**Speed limit**

Define lower and upper limits for the operating speed range using the following parameters:

- 4-11 *Motor Speed Low Limit [RPM]* or
- 4-12 *Motor Speed Low Limit [Hz]* and 4-13 *Motor Speed High Limit [RPM]*, or
- 4-14 *Motor Speed High Limit [Hz]*

For example, the operating speed range can be defined as between 30 and 50/60Hz.

4-19 *Max Output Frequency* limits the maximum output speed the frequency converter can provide.

**ETR**

ETR is an electronic feature that simulates a bimetal relay based on internal measurements. The characteristic is shown in *Illustration 2.18*.

**Voltage limit**

The frequency converter turns off to protect the transistors and the intermediate circuit capacitors when a certain hard-coded voltage level is reached.

**Overtemperature**

The frequency converter has built-in temperature sensors and reacts immediately to critical values via hard-coded limits.

### 2.5.7 Automatic Derating

The frequency converter constantly checks for critical levels:

- High temperature on the control card or heat sink
- High motor load
- High DC-link voltage
- Low motor speed

As a response to a critical level, the frequency converter adjusts the switching frequency. For high internal temperatures and low motor speed, the frequency converters can also force the PWM pattern to SFAVM.

**NOTICE**

The automatic derating is different when 14-55 *Output Filter* is set to [2] *Sine-Wave Filter Fixed*.

### 2.5.8 Automatic Energy Optimisation

Automatic energy optimisation (AEO) directs the frequency converter to continuously monitor the load on the motor and adjust the output voltage to maximise efficiency. Under light load, the voltage is reduced and the motor current is minimised. The motor benefits from increased efficiency, reduced heating, and quieter operation. There is no need to select a V/Hz curve because the frequency converter automatically adjusts motor voltage.

### 2.5.9 Automatic Switching Frequency Modulation

The frequency converter generates short electrical pulses to form an AC wave pattern. The switching frequency is the rate of these pulses. A low switching frequency (slow pulsing rate) causes audible noise in the motor, making a higher switching frequency preferable. A high switching frequency, however, generates heat in the frequency converter which can limit the amount of current available to the motor.

Automatic switching frequency modulation regulates these conditions automatically to provide the highest switching frequency without overheating the frequency converter. By providing a regulated high switching frequency, it quiets motor operating noise at slow speeds, when audible noise control is critical, and produces full output power to the motor when the demand requires.

### 2.5.10 Automatic Derating for High Switching Frequency

The frequency converter is designed for continuous, full load operation at switching frequencies between 3.0 and 4.5 kHz (note that this frequency range is dependent on power size). A switching frequency which exceeds the maximum permissible range generates increased heat in the frequency converter and requires the output current to be derated.

An automatic feature of the frequency converter is load-dependent switching frequency control. This feature allows the motor to benefit from as high a switching frequency as the load permits.

### 2.5.11 Automatic Derating for Overtemperature

Automatic overtemperature derating works to prevent tripping the frequency converter at high temperature. Internal temperature sensors measure conditions to protect the power components from overheating. The converter can automatically reduce its switching frequency to maintain its operating temperature within safe limits. After reducing the switching frequency, the converter can also reduce the output frequency and current by as much as 30% to avoid an overtemperature trip.

### 2.5.12 Auto Ramping

A motor trying to accelerate a load too quickly for the current available can cause the converter to trip. The same is true for too quick a deceleration. Auto ramping protects against this by extending the motor ramping rate

(acceleration or deceleration) to match the available current.

### 2.5.13 Current Limit Circuit

When a load exceed the current capability of the frequency converter normal operation (from an undersized converter or motor), current limit reduces the output frequency to slow the motor and reduce the load. An adjustable timer is available to limit operation in this condition for 60 s or less. The factory default limit is 110% of the rated motor current to minimise overcurrent stress.

### 2.5.14 Power Fluctuation Performance

The frequency converter withstands mains fluctuations such as transients, momentary drop-outs, short voltage drops and surges. The frequency converter automatically compensates for input voltages  $\pm 10\%$  from the nominal to provide full rated motor voltage and torque. With auto restart selected, the frequency converter automatically powers up after a voltage trip. With flying start, the frequency converter synchronises to motor rotation before start.

### 2.5.15 Motor Soft Start

The frequency converter supplies the right amount of current to the motor to overcome load inertia and bring the motor up to speed. This avoids full mains voltage being applied to a stationary or slow turning motor, which generates high current and heat. This inherent soft start feature reduces thermal load and mechanical stress, extends motor life, and provides quieter system operation.

### 2.5.16 Resonance Damping

High frequency motor resonance noise can be eliminated through resonance damping. Automatic or manually selected frequency damping is available.

### 2.5.17 Temperature-controlled Fans

The internal cooling fans are temperature controlled by sensors in the frequency converter. The cooling fan often is not running during low load operation or when in sleep mode or standby. This reduces noise, increases efficiency, and extends the operating life of the fan.

### 2.5.18 EMC Compliance

Electromagnetic interference (EMI) or radio frequency interference (RFI, in case of radio frequency) is disturbance that can affect an electrical circuit due to electromagnetic induction or radiation from an external source. The

frequency converter is designed to comply with the EMC product standard for drives IEC 61800-3 as well as the European standard EN 55011. To comply with the emission levels in EN 55011, the motor cable must be shielded and properly terminated. For more information regarding EMC performance, see *chapter 3.2.2 EMC Test Results*.

### 2.5.19 Current Measurement on All Three Motor Phases

Output current to the motor is continuously measured on all 3 phases to protect both the frequency converter and motor against short-circuits, ground faults, and phase loss. Output ground faults are instantly detected. If a motor phase is lost, the frequency converter stops immediately and reports which phase is missing.

### 2.5.20 Galvanic Isolation of Control Terminals

All control terminals and output relay terminals are galvanically isolated from mains power. This means the controller circuitry is completely protected from the input current. The output relay terminals require their own grounding. This isolation meets the stringent protective extra-low voltage (PELV) requirements for isolation.

The components that make up the galvanic isolation are:

- Power supply, including signal isolation.
- Gate drive for the IGBTs, trigger transformers, and optocouplers.
- The output current Hall effect transducers.

## 2.6 Custom Application Functions

Custom application features are the most common features programmed in the frequency converter for enhanced system performance. They require minimum programming or set-up. Understanding that these features are available can optimise the system design and possibly avoid introducing redundant components or functionality. See the *programming guide* for instructions on activating these functions.

### 2.6.1 Automatic Motor Adaptation

Automatic motor adaptation (AMA) is an automated test procedure used to measure the electrical characteristics of the motor. AMA provides an accurate electronic model of the motor. It allows the frequency converter to calculate optimal performance and efficiency with the motor. Running the AMA procedure also maximises the automatic energy optimisation feature of the frequency converter. AMA is performed without the motor rotating and without uncoupling the load from the motor.

## 2.6.2 Motor Thermal Protection

Motor thermal protection can be provided in 3 ways:

- Via direct temperature sensing via one of the following:
  - PTC sensor in the motor windings and connected on a standard AI or DI.
  - PT100 or PT1000 in the motor windings and motor bearings, connected on VLT® Sensor Input Card MCB 114.
  - PTC thermistor input on VLT® PTC Thermistor Card MCB 112 (ATEX approved).
- Mechanical thermal switch (Klixon type) on a DI.
- Via the built-in electronic thermal relay (ETR) for asynchronous motors.

ETR calculates motor temperature by measuring current, frequency, and operating time. The frequency converter displays the thermal load on the motor in percentage and can issue a warning at a programmable overload setpoint. Programmable options at the overload allow the frequency converter to stop the motor, reduce output, or ignore the condition. Even at low speeds, the frequency converter meets I2t Class 20 electronic motor overload standards.

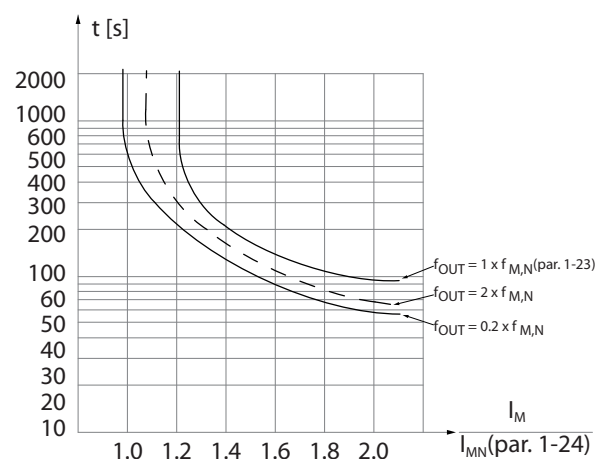


Illustration 2.18 ETR Characteristics

The X-axis in *Illustration 2.18* shows the ratio between  $I_{\text{motor}}$  and  $I_{\text{motor}}$  nominal. The Y-axis shows the time in seconds before the ETR cuts off and trips the frequency converter. The curves show the characteristic nominal speed, at twice the nominal speed and at 0.2 x the nominal speed. At lower speed, the ETR cuts off at lower heat due to less cooling of the motor. In that way, the motor is protected from being overheated even at low speed. The ETR feature calculates the motor temperature based on actual current and speed. The calculated temperature is visible as a read-out parameter in *16-18 Motor Thermal*.

### 2.6.3 Mains Drop-out

During a mains drop-out, the frequency converter keeps running until the intermediate circuit voltage drops below the minimum stop level, which is typically 15% below the lowest rated supply voltage. The mains voltage before the drop-out and the motor load determines how long it takes for the frequency converter to coast.

The frequency converter can be configured (*14-10 Mains Failure*) to different types of behaviour during mains drop-out,

- Trip Lock once the DC link is exhausted.
- Coast with flying start whenever mains return (*1-73 Flying Start*).
- Kinetic back-up.
- Controlled ramp-down.

#### Flying start

This selection makes it possible to catch a motor that is spinning freely due to a mains drop-out. This option is relevant for centrifuges and fans.

#### Kinetic back-up

This selection ensures that the frequency converter runs as long as there is energy in the system. For short mains drop-out, the operation is restored upon mains return, without bringing the application to a stop or losing control at any time. Several variants of kinetic back-up can be selected.

Configure the behaviour of the frequency converter at mains drop-out, in *14-10 Mains Failure* and *1-73 Flying Start*.

### 2.6.4 Built-in PID Controllers

The 4 built-in proportional, integral, derivative (PID) controllers eliminate the need for auxiliary control devices.

One of the PID controllers maintains constant control of closed-loop systems where regulated pressure, flow, temperature, or other system requirements must be maintained. The frequency converter can provide self-reliant control of the motor speed in response to feedback signals from remote sensors. The frequency converter accommodates 2 feedback signals from 2 different devices. This feature allows regulating a system with different feedback requirements. The frequency converter makes control decisions by comparing the 2 signals to optimise system performance.

Use the 3 additional and independent controllers for controlling other process equipment, such as chemical feed pumps, valve control or for aeration with different levels.

### 2.6.5 Automatic Restart

The frequency converter can be programmed to automatically restart the motor after a minor trip, such as momentary power loss or fluctuation. This feature eliminates the need for manual resetting and enhances automated operation for remotely controlled systems. The number of restart attempts as well as the duration between attempts can be limited.

### 2.6.6 Flying Start

Flying start allows the frequency converter to synchronise with an operating motor rotating at up to full speed, in either direction. This prevents trips due to overcurrent draw. It minimises mechanical stress to the system since the motor receives no abrupt change in speed when the frequency converter starts.

### 2.6.7 Full Torque at Reduced Speed

The frequency converter follows a variable V/Hz curve to provide full motor torque even at reduced speeds. Full output torque can coincide with the maximum designed operating speed of the motor. This is unlike variable torque converters that provide reduced motor torque at low speed, or constant torque converters that provide excess voltage, heat, and motor noise at less than full speed.

### 2.6.8 Frequency Bypass

In some applications, the system may have operational speeds that create a mechanical resonance. This can generate excessive noise and possibly damage mechanical components in the system. The frequency converter has 4 programmable bypass-frequency bandwidths. These allow the motor to step over speeds that induce system resonance.

### 2.6.9 Motor Preheat

To preheat a motor in a cold or damp environment, a small amount of DC current can be trickled continuously into the motor to protect it from condensation and a cold start. This can eliminate the need for a space heater.

### 2.6.10 Four Programmable Set-ups

The frequency converter has 4 set-ups that can be independently programmed. Using multi-setup, it is possible to switch between independently programmed functions activated by digital inputs or a serial command. Independent set-ups are used, for example, to change references, or for day/night or summer/winter operation, or



to control multiple motors. The active set-up is displayed on the LCP.

Setup data can be copied from frequency converter to frequency converter by downloading the information from the removable LCP.

### 2.6.11 Dynamic Braking

Dynamic Brake is established by:

- **Resistor brake**  
A brake IGBT keeps the overvoltage under a certain threshold by directing the brake energy from the motor to the connected brake resistor (2-10 Brake Function = [1]).
- **AC brake**  
The brake energy is distributed in the motor by changing the loss conditions in the motor. The AC brake function cannot be used in applications with high cycling frequency since this overheats the motor (2-10 Brake Function = [2]).

### 2.6.12 DC Braking

Some applications may require braking a motor to slow or stop it. Applying DC current to the motor brakes the motor and can eliminate the need for a separate motor brake. DC braking can be set to activate at a predetermined frequency or upon receiving a signal. The rate of braking can also be programmed.

### 2.6.13 Sleep Mode

Sleep mode automatically stops the motor when demand is low for a specified period of time. When the system demand increases, the converter restarts the motor. Sleep mode provides energy savings and reduces motor wear. Unlike a setback clock, the converter is always available to run when the preset wake-up demand is reached.

### 2.6.14 Run Permissive

The converter can wait for a remote *system ready* signal before starting. When this feature is active, the converter remains stopped until receiving permission to start. Run permissive ensures that the system or auxiliary equipment is in the proper state before the converter is allowed to start the motor.

### 2.6.15 Smart Logic Control (SLC)

Smart logic control (SLC) is a sequence of user-defined actions (see 13-52 *SL Controller Action* [x]) executed by the SLC when the associated user defined event (see 13-51 *SL Controller Event* [x]) is evaluated as TRUE by the SLC. The condition for an event can be a particular status or that the output from a logic rule or a comparator operand becomes TRUE. That leads to an associated action as shown in *Illustration 2.19*.

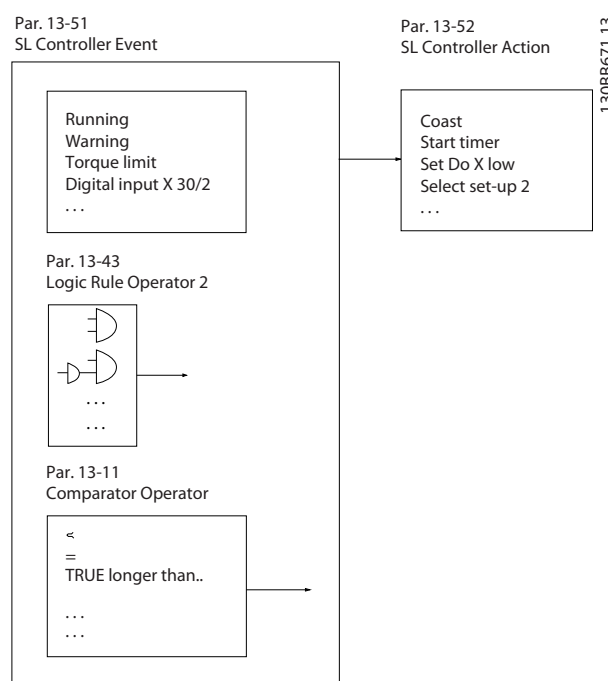
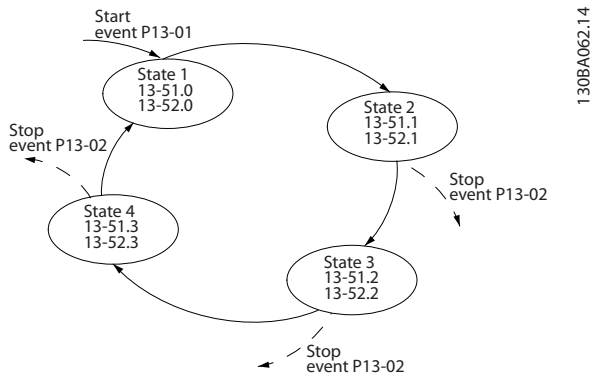


Illustration 2.19 SCL Event and Action

Events and actions are each numbered and linked in pairs (states). This means that when *event* [0] is fulfilled (attains the value TRUE), *action* [0] is executed. After this, the conditions of *event* [1] is evaluated and if evaluated TRUE, *action* [1] is executed and so on. Only one *event* is evaluated at any time. If an *event* is evaluated as FALSE, nothing happens (in the SLC) during the current scan interval and no other *events* are evaluated. This means that when the SLC starts, it evaluates *event* [0] (and only *event* [0]) each scan interval. Only when *event* [0] is evaluated TRUE, the SLC executes *action* [0] and starts evaluating *event* [1]. It is possible to programme from 1 to 20 *events* and *actions*.

When the last *event/action* has been executed, the sequence starts over again from *event* [0]/*action* [0].

*Illustration 2.20* shows an example with 4 *event/actions*:



130BA062.14

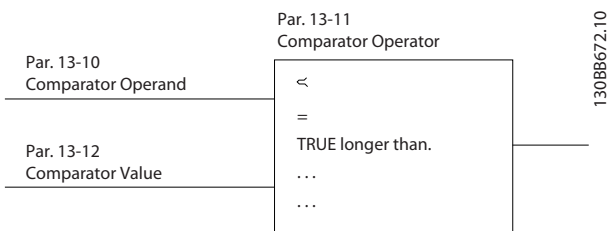
Illustration 2.20 Order of Execution when 4 Events/Actions are Programmed

### 2.6.16 STO Function

The frequency converter is available with STO functionality via control terminal 37. STO disables the control voltage of the power semiconductors of the frequency converter output stage. This in turn prevents generating the voltage required to rotate the motor. When the STO (terminal 37) is activated, the frequency converter issues an alarm, trips the unit, and coasts the motor to a stop. Manual restart is required. The STO function can be used as an emergency stop for the frequency converter. In the normal operating mode when STO is not required, use the regular stop function. When using automatic restart, ensure the requirements of ISO 12100-2 paragraph 5.3.2.5 are fulfilled.

### Comparators

Comparators are used for comparing continuous variables (output frequency, output current, analog input etc.) to fixed preset values.

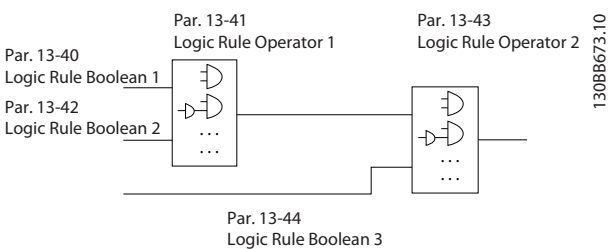


130BB672.10

Illustration 2.21 Comparators

### Logic Rules

Combine up to 3 boolean inputs (TRUE/FALSE inputs) from timers, comparators, digital inputs, status bits and events using the logical operators AND, OR, and NOT.



130BB673.10

Illustration 2.22 Logic Rules

The logic rules, timers, and comparators are also available for use outside of the SLC sequence.

For an example of SLC, refer to *chapter 4.3 Application Setup Examples.3*

### Liability conditions

It is the responsibility of the user to ensure personnel installing and operating the STO function:

- Read and understand the safety regulations concerning health, safety, and accident prevention.
- Have a good knowledge of the generic and safety standards applicable to the specific application.

A user is defined as:

- Integrator
- Operator
- Service technician
- Maintenance technician

### Standards

Use of STO on terminal 37 requires that the user satisfies all provisions for safety including relevant laws, regulations and guidelines. The optional STO function complies with the following standards:

- EN 954-1: 1996 Category 3
- IEC 60204-1: 2005 category 0 – uncontrolled stop
- IEC 61508: 1998 SIL2
- IEC 61800-5-2: 2007 – STO function
- IEC 62061: 2005 SIL CL2
- ISO 13849-1: 2006 Category 3 PL d
- ISO 14118: 2000 (EN 1037) – prevention of unexpected startup

The information and instructions here are not sufficient for a proper and safe use of the STO functionality. For full information about STO, refer to the *VLT® Safe Torque Off Operating Instructions*.

## Protective measures

- Qualified and skilled personnel are required for installation and commissioning of safety engineering systems.
- The unit must be installed in an IP54 cabinet or in an equivalent environment. In special applications, a higher IP degree is required.
- The cable between terminal 37 and the external safety device must be short-circuit protected according to ISO 13849-2 table D.4.
- When external forces influence the motor axis (for example, suspended loads), to eliminate potential hazards, additional measures are required (for example, a safety holding brake).

## 2.7 Fault, Warning and Alarm Functions

The frequency converter monitors many aspects of system operation including mains conditions, motor load and performance, as well as converter status. An alarm or warning does not necessarily indicate a problem with the frequency converter itself. It may be a condition outside of the converter that is being monitored for performance limits. The converter has various pre-programmed fault, warning and alarm responses. Select additional alarm and warning features to enhance or modify system performance.

This section describes common alarm and warning features. Understanding that these features are available can optimise a system design and possibly avoid introducing redundant components or functionality.

### 2.7.1 Operation at Overtemperature

By default, the frequency converter issues an alarm and trip at overtemperature. If *Autoderate and Warning* is selected, the frequency converter will warn of the condition but continue to run and attempt to cool itself by first reducing its switching frequency. Then, if necessary, it reduces the output frequency.

Autoderating does not replace the user settings for derating for ambient temperature (see *chapter 5.3 Derating for Ambient Temperature*).

### 2.7.2 High and Low Reference Warning

In open-loop operation, the reference signal directly determines the speed of the converter. The display shows a flashing reference high or low warning when the programmed maximum or minimum is reached.

### 2.7.3 High and Low Feedback Warning

In closed-loop operation, the selected high and low feedback values are monitored by the converter. The display shows a flashing high or flashing low warning when appropriate. The converter can also monitor feedback signals in open-loop operation. While the signals do not affect the operation of the converter in open loop, they can be useful for system status indication locally or via serial communication. The frequency converter handles 39 different units of measure.

### 2.7.4 Phase Imbalance or Phase Loss

Excessive ripple current in the DC bus indicates either a mains phase imbalance or phase loss. When a power phase to the converter is lost, the default action is to issue an alarm and trip the unit to protect the DC bus capacitors. Other options are to issue a warning and reduce output current to 30% of full current or to issue a warning and continue normal operation. Operating a unit connected to an imbalanced line may be desirable until the imbalance is corrected.

### 2.7.5 High Frequency Warning

Useful in staging on additional equipment such as pumps or cooling fans, the converter can warn when the motor speed is high. A specific high frequency setting can be entered into the converter. If the output exceeds the set warning frequency, the unit displays a high frequency warning. A digital output from the converter can signal external devices to stage on.

### 2.7.6 Low Frequency Warning

Useful in staging off equipment, the converter can warn when the motor speed is low. A specific low frequency setting can be selected for warning and to stage off external devices. The unit will not issue a low frequency warning when it is stopped nor upon start up until after the operating frequency has been reached.

### 2.7.7 High Current Warning

This function is similar to high frequency warning, except a high current setting is used to issue a warning and stage on additional equipment. The function is not active when stopped or at start up until the set operating current has been reached.

### 2.7.8 Low Current Warning

This function is similar to low frequency warning (see *chapter 2.7.6 Low Frequency Warning*), except a low current setting is used to issue a warning and stage off equipment. The function is not active when stopped or at start up until the set operating current has been reached.

### 2.7.9 No Load/Broken Belt Warning

This feature can be used for monitoring a no-load condition, for example a V-belt. After a low current limit has been stored in the converter, if loss of the load is detected, the converter can be programmed to issue an alarm and trip or to continue operation and issue a warning.

### 2.7.10 Lost Serial Interface

The frequency converter can detect loss of serial communication. A time delay of up to 99 s is selectable to avoid a response due to interruptions on the serial communications bus. When the delay is exceeded, options available include for the unit to:

- Maintain its last speed.
- Go to maximum speed.
- Go to a preset speed.
- Stop and issue a warning.

## 2.8 User Interfaces and Programming

The frequency converter uses parameters for programming its application functions. Parameters provide a description of a function and a menu of options to either select from or for entering numeric values. A sample programming menu is shown in *Illustration 2.23*.

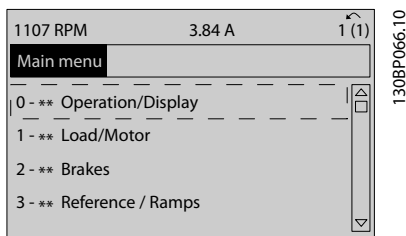


Illustration 2.23 Sample Programming Menu

#### Local user interface

For local programming, parameters are accessible by pressing either [Quick Menu] or [Main Menu] on the LCP.

The Quick Menu is intended for initial start up and motor characteristics. The Main Menu accesses all parameters and allows for advanced applications programming.

#### Remote user interface

For remote programming, Danfoss offers a software program for developing, storing, and transferring programming information. MCT 10 Set-up Software allows the user to connect a PC to the frequency converter and perform live programming rather than using the LCP keypad. Or programming can be done off-line and simply downloaded to the unit. The entire converter profile can be loaded onto the PC for back-up storage or analysis. A USB connector and RS485 terminal are available for connecting to the frequency converter.

MCT 10 Set-up Software is available for free download at [www.VLT-software.com](http://www.VLT-software.com). A CD is also available by requesting part number 130B1000. A user's manual provides detailed operation instructions. See also *chapter 2.8.2 PC Software*.

#### Programming control terminals

- Each control terminal has specified functions it is capable of performing.
- Parameters associated with the terminal enable the function selections.
- For proper converter functioning using control terminals, the terminals must be:
  - Wired properly.
  - Programmed for the intended function.

### 2.8.1 Local Control Panel

The local control panel (LCP) is a graphic display on the front of the unit, which provides the user interface through push-button controls and displays status messages, warnings and alarms, programming parameters, and more. A numeric display is also available with limited display options. *Illustration 2.24* shows the LCP.

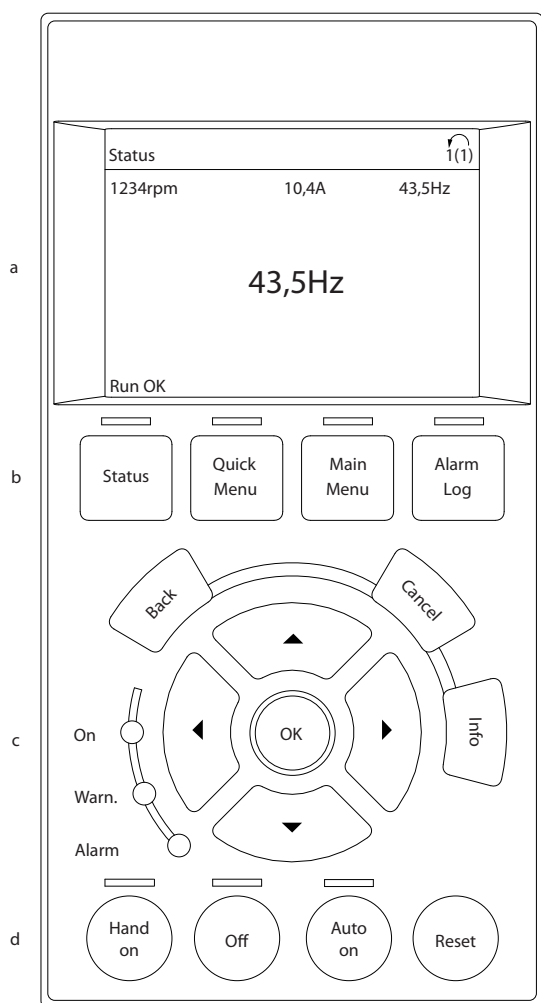


Illustration 2.24 Local Control Panel

## 2.8.2 PC Software

The PC is connected via a standard (host/device) USB cable, or via the RS485 interface.

USB is a serial bus utilising 4 shielded wires with ground pin 4 connected to the shield in the PC USB port. By connecting the PC to a frequency converter through the USB cable, there is a potential risk of damaging the PC USB host controller. All standard PCs are manufactured without galvanic isolation in the USB port.

Any ground potential difference caused by not following the recommendations described in the *operating instructions*, can damage the USB host controller through the shield of the USB cable.

It is recommended to use a USB isolator with galvanic isolation to protect the PC USB host controller from ground potential differences, when connecting the PC to a frequency converter through a USB cable.

Do not to use a PC power cable with a ground plug when the PC is connected to the frequency converter through a USB cable. It reduces the ground potential difference, but

does not eliminate all potential differences due to the ground and shield connected in the PC USB port.

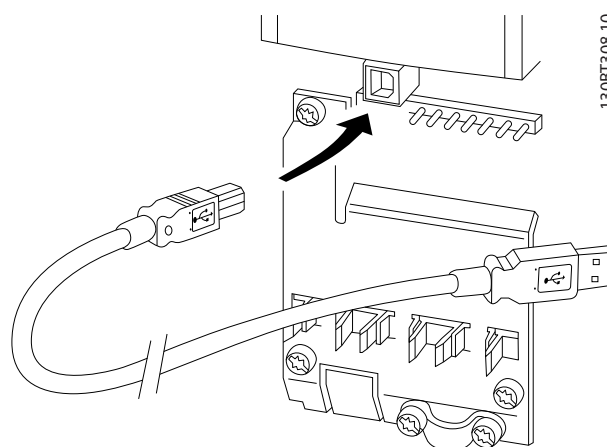


Illustration 2.25 USB Connection

### 2.8.2.1 MCT 10 Set-up Software

The MCT 10 Set-up Software is designed for commissioning and servicing the frequency converter including guided programming of cascade controller, real-time clock, smart logic controller, and preventive maintenance. This software provides easy control of details as well as a general overview of systems, large or small. The tool handles all frequency converter series, VLT® advanced active filters and VLT® soft starter related data.

#### Example 1: Data storage in PC via MCT 10 Set-up Software

1. Connect a PC to the unit via USB or via the RS485 interface.
2. Open MCT 10 Set-up Software.
3. Select the USB port or the RS485 interface.
4. Select *copy*.
5. Select the *project* section.
6. Select *paste*.
7. Select *save as*.

All parameters are now stored.

#### Example 2: Data transfer from PC to frequency converter via MCT 10 Set-up Software

1. Connect a PC to the unit via USB port or via the RS485 interface.
2. Open MCT 10 Set-up Software.
3. Select *Open* – stored files are shown.
4. Open the appropriate file.
5. Select *Write to drive*.

All parameters are now transferred to the frequency converter.

A separate manual for MCT 10 Set-up Software is available. Download the software and the manual from [www.danfoss.com/BusinessAreas/DrivesSolutions/Software-download/](http://www.danfoss.com/BusinessAreas/DrivesSolutions/Software-download/).

### 2.8.2.2 VLT® Harmonics Calculation Software MCT 31

The MCT 31 harmonic calculation PC tool enables easy estimation of the harmonic distortion in a given application. Both the harmonic distortion of Danfoss frequency converters as well as non-Danfoss frequency converters with additional harmonic reduction devices, such as Danfoss AHF filters and 12-18-pulse rectifiers, can be calculated.

MCT 31 can also be downloaded from [www.danfoss.com/BusinessAreas/DrivesSolutions/Software-download/](http://www.danfoss.com/BusinessAreas/DrivesSolutions/Software-download/).

### 2.8.2.3 Harmonic Calculation Software (HCS)

HCS is an advanced version of the harmonic calculation tool. The calculated results are compared to relevant norms and can be printed afterwards.

For more information, see [www.danfoss-hcs.com/Default.asp?LEVEL=START](http://www.danfoss-hcs.com/Default.asp?LEVEL=START)

## 2.9 Maintenance

Danfoss frequency converter models up to 90 kW are maintenance-free. High power frequency converters (rated at 110 kW or higher) have built-in filter mats, which require periodic cleaning by the operator, depending on the exposure to dust and contaminants. Maintenance intervals for the cooling fans (approximately 3 years) and capacitors (approximately 5 years) are recommended in most environments.

### 2.9.1 Storage

Like all electronic equipment, frequency converters must be stored in a dry location. Periodic forming (capacitor charging) is not necessary during storage.

It is recommended to keep the equipment sealed in its packaging until installation.

## 3 System Integration

This chapter describes the considerations necessary to integrate the frequency converter into a system design.

The chapter is divided into these sections:

- *Chapter 3.1 Ambient Operating Conditions*  
Ambient operating conditions for the frequency converter including environment, enclosures, temperature, derating, and other considerations.
- *Chapter 3.3 Mains Integration*  
Input into the frequency converter from the mains side including power, harmonics, monitoring, cabling, fusing, and other considerations.
- *Chapter 3.2 EMC, Harmonics and Earth Leakage Protection*  
Input (regeneration) from the frequency converter to the power grid including power, harmonics, monitoring, and other considerations.
- *Chapter 3.4 Motor Integration*  
Output from the frequency converter to the motor including motor types, load, monitoring, cabling, and other considerations.
- *Chapter 3.5 Additional Inputs and Outputs, Chapter 3.6 Mechanical Planning*  
Integration of the frequency converter input and output for optimal system design including frequency converter/motor matching, system characteristics, and other considerations.

A comprehensive system design anticipates potential problem areas while implementing the most effective combination of converter features. The information that follows provides guidelines for planning and specifying a motor-control system incorporating frequency converters.

Operational features provide a range of design concepts, from simple motor speed control to a fully integrated automation system with feedback handling, operational status reporting, automated fault responses, remote programming, and more.

A complete design concept includes detailed specification of needs and use.

- Frequency converter types
- Motors
- Mains requirements
- Control structure and programming
- Serial communication
- Equipment size, shape, weight

- Power and control cabling requirements; type and length
- Fuses
- Auxiliary equipment
- Transportation and storage

See *chapter 3.9 System Design Checklist* for a practical guide for selection and design.

Understanding features and strategy options can optimise a system design and possibly avoid introducing redundant components or functionality.

### 3.1 Ambient Operating Conditions

#### 3.1.1 Humidity

Although the frequency converter can operate properly at high humidity (up to 95% relative humidity), avoid condensation. There is a specific risk of condensation when the frequency converter is colder than moist ambient air. Moisture in the air can also condense on the electronic components and cause short-circuits. Condensation occurs in units without power. It is advisable to install a cabinet heater when condensation is possible due to ambient conditions. Avoid installation in areas subject to frost.

Alternatively, operating the frequency converter in stand-by mode (with the unit connected to the mains) reduces the risk of condensation. Ensure the power dissipation is sufficient to keep the frequency converter circuitry free of moisture.

#### 3.1.2 Temperature

Minimum and maximum ambient temperature limits are specified for all frequency converters. Avoiding extreme ambient temperatures prolongs the life of the equipment and maximises overall system reliability. Follow the recommendations listed for maximum performance and equipment longevity.

- Although the frequency converter can operate at temperatures down to -10 °C, proper operation at rated load is only guaranteed at 0 °C or higher.
- Do not exceed the maximum temperature limit.
- The lifetime of electronic components decreases by 50% for every 10 °C when operated above the design temperature.
- Even devices with IP54, IP55, or IP66 protection ratings must adhere to the specified ambient temperature ranges.

- Additional air conditioning of the cabinet or installation site may be required.

### 3.1.3 Cooling

Frequency converters dissipate power in the form of heat. The following recommendations are necessary for effective cooling of the units.

- Maximum air temperature to enter enclosure must never exceed 40 °C (104 °F).
- Day/night average temperature must not exceed 35 °C (95 °F).
- Mount the unit to allow for free cooling airflow through the cooling fins. See *chapter 3.6.1 Clearance* for correct mounting clearances.
- Provide minimum front and rear clearance requirements for cooling airflow. See the *operating instructions* for proper installation requirements.

#### 3.1.3.1 Fans

The frequency converter has built-in fans to ensure optimum cooling. The main fan forces the air flow along the cooling fins on the heat sink, ensuring a cooling of the internal air. Some power sizes have a small secondary fan close to the control card, ensuring that the internal air is circulated to avoid hot spots.

The main fan is controlled by the internal temperature in the frequency converter and the speed gradually increases along with temperature, reducing noise and energy consumption when the need is low, and ensuring maximum cooling when the need is there. The fan control can be adapted via *14-52 Fan Control* to accommodate any application, also to protect against negative effects of cooling in cold climates. In case of overtemperature inside the frequency converter, it derates the switching frequency and pattern. See *chapter 5.1 Derating* for more info.

#### 3.1.3.2 Calculation of Airflow Required for Cooling the Frequency Converter

The airflow required to cool a frequency converter, or multiple frequency converters in one enclosure, can be calculated as follows:

1. Determine the power loss at maximum output for all frequency converters from data tables in *chapter 7 Specifications*.
2. Add power loss values of all frequency converters that can operate at same time. The resultant sum is the heat Q to be transferred. Multiply the result

with the factor f, read from *Table 3.1*. For example, f = 3.1 m<sup>3</sup> x K/Wh at sea level.

3. Determine the highest temperature of the air entering the enclosure. Subtract this temperature from the required temperature inside the enclosure, for example 45 °C (113 °F).
4. Divide the total from step 2 by the total from step 3.

The calculation is expressed by the formula:

$$V = \frac{f \times Q}{T_i - T_A}$$

where

V = airflow in m<sup>3</sup>/h

f = factor in m<sup>3</sup> x K/Wh

Q = heat to be transferred in W

T<sub>i</sub> = temperature inside the enclosure in °C

T<sub>A</sub> = ambient temperature in °C

f = cp x ρ (specific heat of air x density of air)

#### **NOTICE**

Specific heat of air (cp) and density of air (ρ) are not constants, but depend on temperature, humidity, and atmospheric pressure. Therefore, they depend on the altitude above sea level.

*Table 3.1* shows typical values of the factor f, calculated for different altitudes.

Altitude	Specific heat of air cp	Density of air ρ	Factor f
[m]	[kJ/kgK]	[kg/m <sup>3</sup> ]	[m <sup>3</sup> ·K/Wh]
0	0.9480	1.225	3.1
500	0.9348	1.167	3.3
1000	0.9250	1.112	3.5
1500	0.8954	1.058	3.8
2000	0.8728	1.006	4.1
2500	0.8551	0.9568	4.4
3000	0.8302	0.9091	4.8
3500	0.8065	0.8633	5.2

**Table 3.1 Factor f, Calculated for Different Altitudes**

#### **Example**

What is the airflow required to cool 2 frequency converters (heat losses 295 W and 1430 W) running simultaneously, mounted in an enclosure with an ambient temperature peak of 37 °C?

1. The sum of the heat losses of both frequency converters is 1725 W.
2. Multiplying 1725 W by 3.3 m<sup>3</sup> x K/Wh gives 5693 m x K/h.
3. Subtracting 37 °C from 45 °C gives 8 °C (=8 K).
4. Dividing 5693 m x K/h by 8 K gives: 711.6 m<sup>3</sup>h.



If the airflow is required in CFM, use the conversion 1 m<sup>3</sup>/h = 0.589 CFM.

For the example above, 711.6 m<sup>3</sup>/h = 418.85 CFM.

### 3.1.4 Motor-generated Overvoltage

The DC voltage in the intermediate circuit (DC bus) increases when the motor acts as a generator. This can occur in 2 ways:

- The load drives the motor when the frequency converter is operated at a constant output frequency. This is generally referred to as an overhauling load.
- During deceleration, if the inertia of the load is high and the deceleration time of the converter is set to a short value.

The frequency converter cannot regenerate energy back to the input. Therefore, it limits the energy accepted from the motor when set to enable autoramping. The frequency converter attempts to do this by automatically lengthening the ramp-down time, if the overvoltage occurs during deceleration. If this is unsuccessful, or if the load drives the motor when operating at a constant frequency, the converter shuts down and displays a fault when a critical DC bus voltage level is reached.

### 3.1.5 Acoustic Noise

Acoustic noise from the frequency converter comes from 3 sources:

- DC-link (intermediate circuit) coils
- RFI filter choke
- Internal fans

See *Table 7.60* for acoustic noise ratings.

### 3.1.6 Vibration and Shock

The frequency converter is tested according to a procedure based on the IEC 68-2-6/34/35 and 36. These tests subject the unit to 0.7 g forces, over the range of 18 to 1000 Hz randomly, in 3 directions, for 2 hours. All Danfoss frequency converters comply with requirements that correspond to these conditions when the unit is wall- or floor-mounted, as well as when mounted within panels, or bolted to walls or floors.

## 3.1.7 Aggressive Atmospheres

### 3.1.7.1 Gases

Aggressive gases, such as hydrogen sulphide, chlorine, or ammonia can damage frequency converter electrical and mechanical components. Contamination of the cooling air can also cause the gradual decomposition of PCB tracks and door seals. Aggressive contaminants are often present in sewage treatment plants or swimming pools. A clear sign of an aggressive atmosphere is corroded copper.

In aggressive atmospheres, restricted IP enclosures are recommended along with conformal-coated circuit boards. See *Table 3.2* for conformal-coating values.

#### **NOTICE**

The frequency converter comes standard with class 3C2 coating of circuit boards. On request, class 3C3 coating is available.

Gas type	Unit	Class				
		3C1	3C2		3C3	
			Average value	Max. value <sup>1)</sup>	Average value	Max. value <sup>1)</sup>
Sea salt	n/a	None	Salt mist		Salt mist	
Sulphur oxides	mg/m <sup>3</sup>	0.1	0.3	1.0	5.0	10
Hydrogen sulphide	mg/m <sup>3</sup>	0.01	0.1	0.5	3.0	10
Chlorine	mg/m <sup>3</sup>	0.01	0.1	0.03	0.3	1.0
Hydrogen chloride	mg/m <sup>3</sup>	0.01	0.1	0.5	1.0	5.0
Hydrogen fluoride	mg/m <sup>3</sup>	0.003	0.01	0.03	0.1	3.0
Ammonia	mg/m <sup>3</sup>	0.3	1.0	3.0	10	35
Ozone	mg/m <sup>3</sup>	0.01	0.05	0.1	0.1	0.3
Nitrogen	mg/m <sup>3</sup>	0.1	0.5	1.0	3.0	9.0

**Table 3.2 Conformal-coating Class Ratings**

<sup>1)</sup> Maximum values are transient peak values not to exceed 30 minutes per day.

### 3.1.7.2 Dust Exposure

Installation of frequency converters in environments with high dust exposure is often unavoidable. Dust affects wall- or frame-mounted units with IP55 or IP66 protection ratings, and also cabinet-mounted devices with IP21 or IP20 protection ratings. Consider the 3 aspects described in this section when frequency converters are installed in such environments.

**Reduced cooling**

Dust forms deposits on the surface of the device and inside on circuit boards and the electronic components. These deposits act as insulation layers and hamper heat transfer to the ambient air, reducing the cooling capacity. The components become warmer. This causes accelerated aging of the electronic components, and the service life of the unit decreases. Dust deposits on the heat sink in the back of the unit also decrease the service life of the unit.

**Cooling fans**

The airflow for cooling the unit is produced by cooling fans, usually located on the back of the device. The fan rotors have small bearings into which dust can penetrate and act as an abrasive. This leads to bearing damage and fan failure.

**Filters**

High-power frequency converters are equipped with cooling fans that expel hot air from the interior of the device. Above a certain size, these fans are fitted with filter mats. These filters can become quickly clogged when used in dusty environments. Preventive measures are necessary under these conditions.

**Periodic maintenance**

Under the conditions described above, it is advisable to clean the frequency converter during periodic maintenance. Remove dust off the heat sink and fans and clean the filter mats.

### 3.1.7.3 Potentially Explosive Atmospheres

Systems operated in potentially explosive atmospheres must fulfill special conditions. EU Directive 94/9/EC describes the operation of electronic devices in potentially explosive atmospheres.

Motors controlled by frequency converters in potentially explosive atmospheres must be monitored for temperature using a PTC temperature sensor. Motors with ignition protection class d or e are approved for this environment.

- d classification consists of ensuring that if a spark occurs, it is contained in a protected area. While not requiring approval, special wiring and containment are required.
- d/e combination is the most often used in potentially explosive atmospheres. The motor itself has an e ignition protection class, while the motor cabling and connection environment is in compliance with the e classification. The restriction on the e connection space consists of the maximum voltage allowed in this space. The output voltage of a frequency converter is usually limited to the mains voltage. The modulation of the output voltage may generate unallowable high peak voltage for e classification. In practice, using a sine-wave filter at the frequency

converter output has proven to be an effective means to attenuate the high peak voltage.

**NOTICE**

**Do not install a frequency converter in a potentially explosive atmosphere. Install the frequency converter in a cabinet outside of this area. Using a sine-wave filter at the output of the frequency converter is also recommended to attenuate the dU/dt voltage rise and peak voltage. Keep the motor cables as short as possible.**

**NOTICE**

**Frequency converters with the MCB 112 option have PTB-certified motor thermistor sensor monitoring capability for potentially explosive atmospheres. Shielded motor cables are not necessary when frequency converters are operated with sine-wave output filters.**

### 3.1.8 IP Rating Definitions

		Against penetration by solid foreign objects	Against access to hazardous parts by
First digit	0	(not protected)	(not protected)
	1	≥50 mm diameter	Back of hand
	2	12.5 mm diameter	Finger
	3	2.5 mm diameter	Tool
	4	≥1.0 mm diameter	Wire
	5	Dust protected	Wire
	6	Dust-tight	Wire
		<b>Against water penetration with harmful effect</b>	
Second digit	0	(not protected)	
	1	Drops falling vertically	
	2	Drops at 15° angle	
	3	Spraying water	
	4	Splashing water	
	5	Water jets	
	6	Powerful water jets	
	7	Temporary immersion	
		<b>Additional information specifically for</b>	
First letter	A		Back of hand
	B		Finger
	C		Tool
	D		Wire
		<b>Additional information specifically for</b>	
Additional letter	H	High-voltage device	
	M	Device moving during water test	
	S	Device stationary during water test	
	W	Weather conditions	

Table 3.3 IEC 60529 Definitions for IP Ratings

#### 3.1.8.1 Cabinet Options and Ratings

Danfoss frequency converters are available with 3 different protection ratings:

- IP00 or IP20 for cabinet installation.
- IP54 or IP55 for local mounting.
- IP66 for critical ambient conditions, such as extremely high (air) humidity or high concentrations of dust or aggressive gases.

### 3.1.9 Radio Frequency Interference

The main objective in practice is to obtain systems that operate stably without radio frequency interference between components. To achieve a high level of immunity, it is recommended to use frequency converters with high-quality RFI filters.

Use Category C1 filters specified in the EN 61800-3 which conform to the Class B limits of the general standard EN 55011.

Place warning notices on the frequency converter if RFI filters do not correspond to Category C1 (Category C2 or lower). The responsibility for proper labelling rests with the operator.

In practice, there are 2 approaches to RFI filters:

- Built in to the equipment
  - Built-in filters take up space in the cabinet but eliminate additional costs for fitting, wiring, and material. However, the most important advantage is the perfect EMC conformance and cabling of integrated filters.
- External options
  - Optional external RFI filters that are installed on the input of the frequency converter cause a voltage drop. In practice, this means that the full mains voltage is not present at the frequency converter input and a higher-rated converter may be necessary. The maximum length of the motor cable for compliance with EMC limits ranges from 1–50 m. Costs are incurred for material, cabling, and assembly. EMC conformance is not tested.

#### **NOTICE**

To ensure interference-free operation of the frequency converter/motor system, always use a category C1 RFI filter.

#### **NOTICE**

VLT® AQUA Drive units are supplied as standard with built-in RFI filters conforming to category C1 (EN 61800-3) for use with 400 V mains systems and power ratings up to 90 kW or category C2 for power ratings of 110 to 630 kW. VLT® AQUA Drive units conform to C1 with shielded motor cables up to 50 m or C2 with shielded motor cables up to 150 m. Refer to Table 3.4 for details.

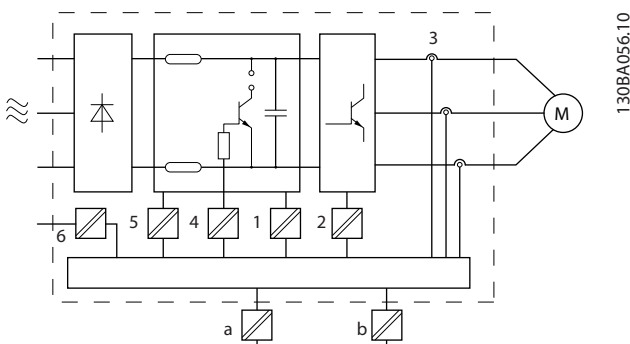
### 3.1.10 PELV and Galvanic Isolation Compliance

Ensure the protection against electric shock, when the electrical supply is of the protective extra-low voltage (PELV) type and the installation complies with local and national PELV regulations.

To maintain PELV at the control terminals, all connections must be PELV, such as thermistors being reinforced/double insulated. All Danfoss frequency converter control and relay terminals comply with PELV (excluding grounded Delta leg above 400 V).

Galvanic (ensured) isolation is obtained by fulfilling requirements for higher isolation and by providing the relevant creepage/clearance distances. These requirements are described in the EN 61800-5-1 standard.

Electrical isolation is provided as shown in *Illustration 3.1*. The components described comply with both PELV and the galvanic isolation requirements.



1	Power supply (SMPS) including signal isolation of V DC, indicating the intermediate current voltage
2	Gate drive for the IGBTs
3	Current transducers
4	Opto-coupler, brake module
5	Internal inrush, RFI, and temperature measurement circuits
6	Custom relays
a	Galvanic isolation for the 24 V back-up option
b	Galvanic isolation for the RS485 standard bus interface

Illustration 3.1 Galvanic Isolation

#### Installation at high altitude

Installations exceeding high altitude limits may not comply with PELV requirements. The isolation between components and critical parts could be insufficient. There is a risk for overvoltage. Reduce the risk for over-voltage using external protective devices or galvanic isolation.

For installations at high altitude, contact Danfoss regarding PELV compliance.

- 380–500 V (enclosure A, B and C): above 2000 m (6500 ft)
- 380–500 V (enclosure D, E, and F): above 3000 m (9800 ft)
- 525–690 V: above 2000 m (6500 ft)

### 3.1.11 Storage

Like all electronic equipment, frequency converters must be stored in a dry location. Periodic forming (capacitor charging) is not necessary during storage.

It is recommended to keep the equipment sealed in its packaging until installation.

## 3.2 EMC, Harmonics and Earth Leakage Protection

### 3.2.1 General Aspects of EMC Emissions

Frequency converters (and other electrical devices) generate electronic or magnetic fields that may interfere with their environment. The electromagnetic compatibility (EMC) of these effects depends on the power and the harmonic characteristics of the devices.

Uncontrolled interaction between electrical devices in a system can degrade compatibility and impair reliable operation. Interference may take the form of mains harmonics distortion, electrostatic discharges, rapid voltage fluctuations, or high-frequency interference. Electrical devices generate interference along with being affected by interference from other generated sources.

Electrical interference usually arises at frequencies in the range 150 kHz to 30 MHz. Airborne interference from the frequency converter system in the range 30 MHz to 1 GHz is generated from the inverter, motor cable, and the motor.

Capacitive currents in the motor cable coupled with a high  $dU/dt$  from the motor voltage generate leakage currents, as shown in *Illustration 3.2*.

The use of a screened motor cable increases the leakage current (see *Illustration 3.2*) because screened cables have higher capacitance to ground than unscreened cables. If the leakage current is not filtered, it causes greater interference on the mains in the radio frequency range below approximately 5 MHz. Since the leakage current ( $I_1$ ) is carried back to the unit through the screen ( $I_2$ ), there is, in principle, only a small electro-magnetic field ( $I_4$ ) from the screened motor cable according to *Illustration 3.2*.

The screen reduces the radiated interference, but increases the low-frequency interference on the mains. Connect the motor cable screen to the frequency converter enclosure

as well as on the motor enclosure. This is best done by using integrated screen clamps so as to avoid twisted screen ends (pigtails). Pigtails increase the screen impedance at higher frequencies, which reduces the screen effect and increases the leakage current ( $I_4$ ).

If a screened cable is used for relay, control cable, signal interface and brake, mount the screen on the enclosure at both ends. In some situations, however, it is necessary to break the screen to avoid current loops.

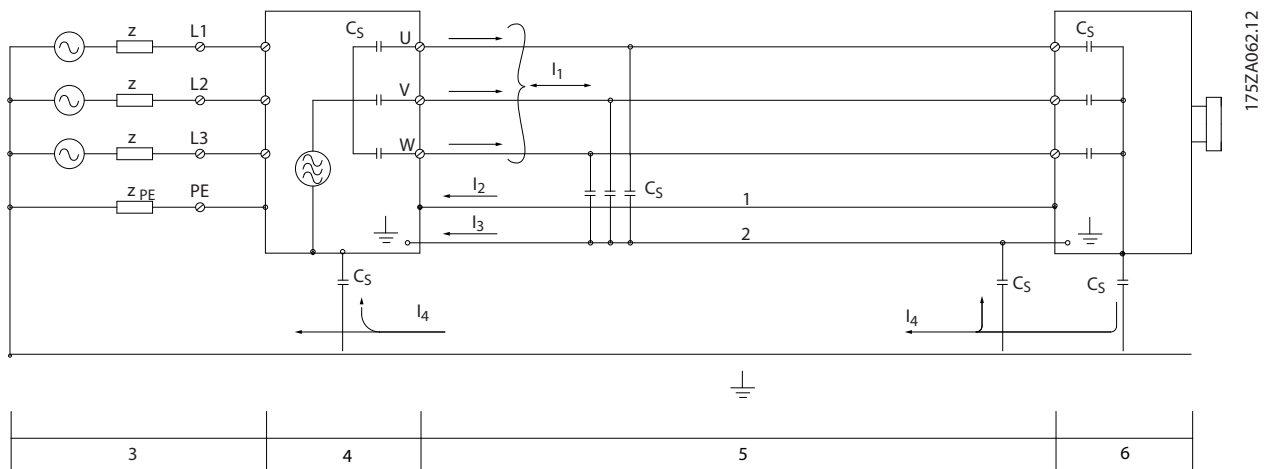
If the screen is to be placed on a mounting plate for the frequency converter, the mounting plate must be made of metal, to convey the screen currents back to the unit. Moreover, ensure good electrical contact from the

mounting plate through the mounting screws to the frequency converter chassis.

When using unscreened cables, some emission requirements are not complied with, although most immunity requirements are observed.

To reduce the interference level from the entire system (unit+installation), make motor and brake cables as short as possible. Avoid placing cables with a sensitive signal level alongside motor and brake cables. Radio interference higher than 50 MHz (airborne) is especially generated by the control electronics.

3



1	Ground wire	3	AC mains supply	5	Screened motor cable
2	Screen	4	Frequency converter	6	Motor

Illustration 3.2 Generation of Leakage Currents

### 3.2.2 EMC Test Results

The following test results have been obtained using a system with a frequency converter, a screened control cable, a control box with potentiometer, as well as a single motor and screened motor cable (Ölflex Classic 100 CY) at nominal switching frequency. *Table 3.4* states the maximum motor cable lengths for compliance.

**3**
**NOTICE**

Conditions may change significantly for other set-ups.

**NOTICE**

 Consult *Table 3.17* for parallel motor cables.

RFI filter type			Conducted emission			Radiated emission		
			Cable length [m]			Cable length [m]		
Standards and requirements	EN 55011	Class B	Class A Group 1	Class A Group 2	Class B	Class A Group 1	Class A Group 2	
		Housing, trades and light industries	Industrial environment	Industrial environment	Housing, trades and light industries	Industrial environment	Industrial environment	
	EN/IEC 61800-3	Category C1	Category C2	Category C3	Category C1	Category C2	Category C3	
		First environment Home and office	First environment Home and office	Second environment Industrial	First environment Home and office	First environment Home and office	Second environment Industrial	
<b>H1</b>								
FC 202	0.25-45 kW 200-240 V	T2	50	150	150	No	Yes	Yes
	1.1-7.5 kW 200-240 V	S2	50	100/150 <sup>5)</sup>	100/150 <sup>5)</sup>	No	Yes	Yes
	0.37-90 kW 380-480 V	T4	50	150	150	No	Yes	Yes
	7.5 kW 380-480 V	S4	50	100/150 <sup>5)</sup>	100/150 <sup>5)</sup>	No	Yes	Yes
<b>H2</b>								
FC 202	0.25-3.7 kW 200-240 V	T2	No	No	5	No	No	No
	5.5-45 kW 200-240 V	T2	No	No	25	No	No	No
	1.1-7.5 kW 200-240 V	S2	No	No	25	No	No	No
	0.37-7.5 kW 380-480 V	T4	No	No	5	No	No	No
	11-90 kW 380-380 V <sup>4)</sup>	T4	No	No	25	No	No	No
	7.5 kW 380-480 V	S4	No	No	25	No	No	No
	11-30 kW 525-690 V <sup>1, 4)</sup>	T7	No	No	25	No	No	No
	37-90 kW 525-690 V <sup>2, 4)</sup>	T7	No	No	25	No	No	No
<b>H3</b>								
FC 202	0.25-45 kW 200-240 V	T2	10	50	50	No	Yes	Yes
	0.37-90 kW 380-480 V	T4	10	50	50	No	Yes	Yes
<b>H4</b>								
FC 202	1.1-30 kW 525-690 V <sup>1)</sup>	T7	No	100	100	No	Yes	Yes
	37-90 kW 525-690 V <sup>2)</sup>	T7	No	150	150	No	Yes	Yes
<b>Hx<sup>1)</sup></b>								
FC 202	1.1-90 kW 525-600 V	T6	No	No	No	No	No	No
	15-22 kW 200-240 V	S2	No	No	No	No	No	No
	11-37 kW 380-480 V	S4	No	No	No	No	No	No

**Table 3.4 EMC Test Results (Emission) Maximum Motor Cable Length**

1) Enclosure size B2.

2) Enclosure size C2.

3) Hx versions can be used according to EN/IEC 61800-3 category C4.

4) T7, 37-90 kW complies with class A group 1 with 25 m motor cable. Some restrictions for the installation apply (contact Danfoss for details).

5) 100 m for phase-neutral, 150 m for phase-phase (but not from TT or TN). Single-phase frequency converters are not intended for 2-phase supply from a TT or TN network.

Hx, H1, H2, H3, H4 or H5 is defined in the type code pos. 16–17 for EMC filters.

Hx – No EMC filters built in the frequency converter.

H1 – Integrated EMC filter. Fulfill EN 55011 Class A1/B and EN/IEC 61800-3 Category 1/2.

H2 – A limited RFI filter only containing capacitors and without a common-mode coil. Fulfill EN 55011 Class A2 and EN/IEC 61800-3 Category 3.

H3 – Integrated EMC filter. Fulfill EN 55011 class A1/B and EN/IEC 61800-3 Category 1/2.

H4 – Integrated EMC filter. Fulfill EN 55011 class A1 and EN/IEC 61800-3 Category 2.

H5 – Marine versions. Ruggedised version, fulfills same emissions levels as H2 versions.

### 3.2.3 Emission Requirements

The EMC product standard for frequency converters defines 4 categories (C1, C2, C3 and C4) with specified requirements for emission and immunity. Table 3.5 states the definition of the 4 categories and the equivalent classification from EN 55011.

Category	Definition	Equivalent emission class in EN 55011
C1	Frequency converters installed in the first environment (home and office) with a supply voltage less than 1000 V.	Class B
C2	Frequency converters installed in the first environment (home and office) with a supply voltage less than 1000 V, which are neither plug-in nor movable and are intended to be installed and commissioned by a professional.	Class A Group 1
C3	Frequency converters installed in the second environment (industrial) with a supply voltage lower than 1000 V.	Class A Group 2
C4	Frequency converters installed in the second environment with a supply voltage equal to or above 1000 V or rated current equal to or above 400 A or intended for use in complex systems.	No limit line. Make an EMC plan.

Table 3.5 Correlation between IEC 61800-3 and EN 55011

When the generic (conducted) emission standards are used, the frequency converters are required to comply with the limits in Table 3.6.

Environment	Generic emission standard	Equivalent emission class in EN 55011
First environment (home and office)	EN/IEC 61000-6-3 Emission standard for residential, commercial and light industrial environments.	Class B

Environment	Generic emission standard	Equivalent emission class in EN 55011
Second environment (industrial environment)	EN/IEC 61000-6-4 Emission standard for industrial environments.	Class A Group 1

Table 3.6 Correlation between Generic Emission Standards and EN 55011

### 3.2.4 Immunity Requirements

The immunity requirements for frequency converters depend on the environment where they are installed. The requirements for the industrial environment are higher than the requirements for the home and office environment. All Danfoss frequency converters comply with the requirements for the industrial environment and consequently comply also with the lower requirements for home and office environment with a large safety margin.

To document immunity against electrical interference, the following immunity tests have been made in accordance with following basic standards:

- **EN 61000-4-2 (IEC 61000-4-2):** Electrostatic discharges (ESD): Simulation of electrostatic discharges from human beings.
- **EN 61000-4-3 (IEC 61000-4-3):** Incoming electromagnetic field radiation, amplitude modulated simulation of the effects of radar and radio communication equipment as well as mobile communications equipment.
- **EN 61000-4-4 (IEC 61000-4-4):** Burst transients: Simulation of interference brought about by switching a contactor, relay or similar devices.
- **EN 61000-4-5 (IEC 61000-4-5):** Surge transients: Simulation of transients brought about for example by lightning that strikes near installations.
- **EN 61000-4-6 (IEC 61000-4-6):** RF Common mode: Simulation of the effect from radio-transmission equipment joined by connection cables.

See Table 3.7.

Basic standard	Burst <sup>2)</sup> IEC 61000-4-42)	Surge <sup>2)</sup> IEC 61000-4-5	ESD <sup>2)</sup> IEC 61000-4-2	Radiated electromagnetic field IEC 61000-4-3	RF common mode voltage IEC 61000-4-6
Acceptance criterion	B	B	B	A	A
Voltage range: 200-240 V, 380-500 V, 525-600 V, 525-690 V					
Line	4 kV CM	2 kV/2 Ω DM 4 kV/12 Ω CM	—	—	10 V <sub>RMS</sub>
Motor	4 kV CM	4 kV/2 Ω <sup>1)</sup>	—	—	10 V <sub>RMS</sub>
Brake	4 kV CM	4 kV/2 Ω <sup>1)</sup>	—	—	10 V <sub>RMS</sub>
Load sharing	4 kV CM	4 kV/2 Ω <sup>1)</sup>	—	—	10 V <sub>RMS</sub>
Control wires	2 kV CM	2 kV/2 Ω <sup>1)</sup>	—	—	10 V <sub>RMS</sub>
Standard bus	2 kV CM	2 kV/2 Ω <sup>1)</sup>	—	—	10 V <sub>RMS</sub>
Relay wires	2 kV CM	2 kV/2 Ω <sup>1)</sup>	—	—	10 V <sub>RMS</sub>
Application and Fieldbus options	2 kV CM	2 kV/2 Ω <sup>1)</sup>	—	—	10 V <sub>RMS</sub>
LCP cable	2 kV CM	2 kV/2 Ω <sup>1)</sup>	—	—	10 V <sub>RMS</sub>
External 24 V DC	2 V CM	0.5 kV/2 Ω DM 1 kV/12 Ω CM	—	—	10 V <sub>RMS</sub>
Enclosure	—	—	8 kV AD 6 kV CD	10 V/m	—

**Table 3.7 EMC Immunity Form**

1) Injection on cable shield

2) Values typically obtained by testing

### 3.2.5 Motor Insulation

Modern motors for use with frequency converters have a high degree of insulation to account for new generation high-efficiency IGBTs with high dU/dt. For retrofit in old motors, confirm the motor insulation or mitigate with dU/dt filter or, if necessary, a sine-wave filter.

For motor cable lengths ≤ the maximum cable length listed in *chapter 7.5 Cable Specifications*, the motor insulation ratings listed in *Table 3.8* are recommended. If a motor has lower insulation rating, it is recommended to use a dU/dt or sine-wave filter.

Nominal mains voltage [V]	Motor insulation [V]
U <sub>N</sub> ≤ 420	Standard U <sub>LL</sub> = 1300
420 V < U <sub>N</sub> ≤ 500	Reinforced U <sub>LL</sub> = 1600
500 V < U <sub>N</sub> ≤ 600	Reinforced U <sub>LL</sub> = 1800
600 V < U <sub>N</sub> ≤ 690	Reinforced U <sub>LL</sub> = 2000

**Table 3.8 Motor Insulation**

### 3.2.6 Motor Bearing Currents

To minimise bearing and shaft currents, ground the following to the driven machine:

- Frequency converter
- Motor
- Driven machine

#### Standard mitigation strategies

1. Use an insulated bearing.
2. Apply rigorous installation procedures:
  - 2a Ensure that the motor and load motor are aligned.
  - 2b Strictly follow the EMC Installation guideline.
  - 2c Reinforce the PE so the high frequency impedance is lower in the PE than the input power leads.
  - 2d Provide a good high frequency connection between the motor and the frequency converter, for instance, by screened cable which has a 360° connection in the motor and the frequency converter.
  - 2e Make sure that the impedance from frequency converter to building ground



is lower than the grounding impedance of the machine. This can be difficult for pumps.

- 2f Make a direct ground connection between the motor and load motor.
- 3. Lower the IGBT switching frequency.
- 4. Modify the inverter waveform, 60° AVIM vs. SFAVM.
- 5. Install a shaft grounding system or use an isolating coupling.
- 6. Apply conductive lubrication.
- 7. Use minimum speed settings if possible.
- 8. Try to ensure the line voltage is balanced to ground. This can be difficult for IT, TT, TN-CS or Grounded leg systems.
- 9. Use a dU/dt or sine-wave filter.

### 3.2.7 Harmonics

Electrical devices with diode rectifiers, such as fluorescent lights, computers, copiers, fax machines, various laboratory equipment and telecommunications systems, can add harmonic distortion to a mains power supply. Frequency converters use a diode bridge input, which can also contribute to harmonic distortion.

The frequency converter does not draw current uniformly from the power line. This non-sinusoidal current has components that are multiples of the fundamental current frequency. These components are referred to as harmonics. It is important to control the total harmonic distortion on the mains supply. Although the harmonic currents do not directly affect electrical energy consumption, they generate heat in wiring and transformers and can affect other devices on the same power line.

#### 3.2.7.1 Harmonic Analysis

Various characteristics of a building's electrical system determine the exact harmonic contribution of the converter to the THD of a facility and its ability to meet IEEE standards. Generalisations about the harmonic contribution of frequency converters on a specific facility is difficult. When necessary, perform an analysis of the system harmonics to determine equipment effects.

A frequency converter takes up a non-sinusoidal current from mains, which increases the input current I<sub>RMS</sub>. A non-sinusoidal current is transformed by means of a Fourier series analysis and split up into sine-wave currents with different frequencies, i.e. different harmonic currents I<sub>N</sub> with 50 Hz or 60 Hz as the fundamental frequency.

The harmonics do not affect the power consumption directly, but increase the heat losses in the installation

(transformer, inductors, cables). Consequently, in power plants with a high percentage of rectifier load, harmonic currents should be kept at a low level to avoid overload of the transformer, inductors, and cables.

Abbreviation	Description
f <sub>1</sub>	fundamental frequency
I <sub>1</sub>	fundamental current
U <sub>1</sub>	fundamental voltage
I <sub>n</sub>	harmonic currents
U <sub>n</sub>	harmonic voltage
n	harmonic order

Table 3.9 Harmonics-related Abbreviations

	Fundamental current (I <sub>1</sub> )	Harmonic current (I <sub>n</sub> )		
		I <sub>5</sub>	I <sub>7</sub>	I <sub>11</sub>
Current	I <sub>1</sub>	I <sub>5</sub>	I <sub>7</sub>	I <sub>11</sub>
Frequency [Hz]	50	250	350	550

Table 3.10 Transformed Non-sinusoidal Current

Current	Harmonic current				
	I <sub>RMS</sub>	I <sub>1</sub>	I <sub>5</sub>	I <sub>7</sub>	I <sub>11-49</sub>
Input current	1.0	0.9	0.4	0.2	< 0.1

Table 3.11 Harmonic Currents Compared to the RMS Input Current

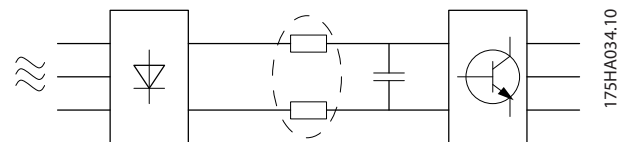


Illustration 3.3 Intermediate Circuit Coils

### NOTICE

Some of the harmonic currents can disturb communication equipment connected to the same transformer or cause resonance in connection with power-factor correction capacitors.

To ensure low harmonic currents, the frequency converter is equipped with passive filters. DC-coils reduce the total harmonic distortion (THD) to 40%.

The voltage distortion on the mains supply voltage depends on the size of the harmonic currents multiplied by the mains impedance for the frequency in question. The total voltage distortion (THD) is calculated on the basis of the individual voltage harmonics using this formula:

$$THD = \frac{\sqrt{U_5^2 + U_7^2 + \dots + U_N^2}}{U_1}$$

### 3.2.7.2 Harmonics Emission Requirements

#### Equipment connected to the public supply network

Option	Definition
1	IEC/EN 61000-3-2 Class A for 3-phase balanced equipment (for professional equipment only up to 1 kW total power).
2	IEC/EN 61000-3-12 Equipment 16 A-75 A and professional equipment as from 1 kW up to 16 A phase current.

Table 3.12 Harmonics Emission Standards

### 3.2.7.3 Harmonics Test Results (Emission)

Power sizes up to PK75 in T2 and T4 complies with IEC/EN 61000-3-2 Class A. Power sizes from P1K1 and up to P18K in T2 and up to P90K in T4 complies with IEC/EN 61000-3-12, Table 4. Power sizes P110 - P450 in T4 also complies with IEC/EN 61000-3-12 even though not required because currents are above 75 A.

Table 3.13 describes that the short-circuit power of the supply  $S_{sc}$  at the interface point between the user's supply and the public system ( $R_{sce}$ ) is greater than or equal to:

$$SSC = \sqrt{3} \times RSCE \times Umains \times Iequ = \sqrt{3} \times 120 \times 400 \times Iequ$$

	Individual harmonic current $I_n/I_1$ (%)			
	$I_5$	$I_7$	$I_{11}$	$I_{13}$
Actual (typical)	40	20	10	8
Limit for $R_{sce} \geq 120$	40	25	15	10
	Harmonic current distortion factor (%)			
	THD	PWHD		
Actual (typical)	46	45		
Limit for $R_{sce} \geq 120$	48	46		

Table 3.13 Harmonics Test Results (Emission)

It is the responsibility of the installer or user of the equipment to ensure, by consultation with the distribution network operator if necessary, that the equipment is connected only to a supply with a short-circuit power  $S_{sc}$  greater than or equal to that specified in the equation. Consult the distribution network operator to connect other power sizes to the public supply network.

Compliance with various system level guidelines: The harmonic current data in Table 3.13 are provided in accordance with IEC/EN61000-3-12 with reference to the power drive systems product standard. They may be used as the basis for calculation of the influence harmonic currents have on the power supply system and for the documentation of compliance with relevant regional guidelines: IEEE 519 -1992; G5/4.

### 3.2.7.4 Effect of Harmonics in a Power Distribution System

In Illustration 3.4 a transformer is connected on the primary side to a point of common coupling PCC1, on the medium voltage supply. The transformer has an impedance  $Z_{xfr}$  and feeds a number of loads. The point of common coupling where all loads are connected together is PCC2. Each load is connected through cables that have an impedance  $Z_1, Z_2, Z_3$ .

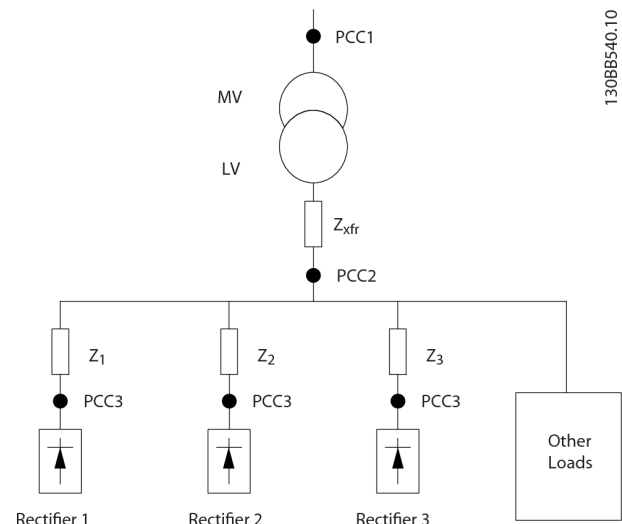


Illustration 3.4 Small Distribution System

Harmonic currents drawn by non-linear loads cause distortion of the voltage because of the voltage drop on the impedances of the distribution system. Higher impedances result in higher levels of voltage distortion.

Current distortion relates to apparatus performance and it relates to the individual load. Voltage distortion relates to system performance. It is not possible to determine the voltage distortion in the PCC knowing only the load's harmonic performance. To predict the distortion in the PCC, the configuration of the distribution system and relevant impedances must be known.

A commonly used term for describing the impedance of a grid is the short-circuit ratio  $R_{sce}$ , defined as the ratio between the short circuit apparent power of the supply at the PCC ( $S_{sc}$ ) and the rated apparent power of the load ( $S_{equ}$ ).

$$R_{sce} = \frac{S_{sc}}{S_{equ}}$$

$$\text{where } S_{sc} = \frac{U^2}{Z_{supply}} \text{ and } S_{equ} = U \times I_{equ}$$

#### The negative effect of harmonics is 2-fold

- Harmonic currents contribute to system losses (in cabling, transformer).
- Harmonic voltage distortion causes disturbance to other loads and increase losses in other loads.

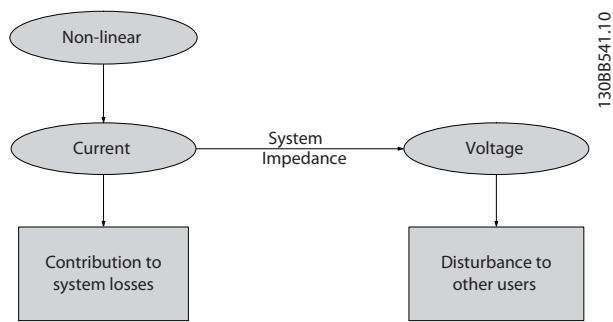


Illustration 3.5 Negative Effects of Harmonics

### 3.2.7.5 Harmonic Limitation Standards and Requirements

The requirements for harmonic limitation can be:

- Application-specific requirements.
- Standards that must be observed.

The application-specific requirements are related to a specific installation where there are technical reasons for limiting the harmonics.

**Example**

A 250 kVA transformer with 2 110 kW motors connected is sufficient, if one of the motors is connected directly online and the other is supplied through a frequency converter. However, the transformer is undersized if both motors are frequency-converter supplied. Using additional means of harmonic reduction within the installation or selecting low harmonic drive variants makes it possible for both motors to run with frequency converters.

There are various harmonic mitigation standards, regulations, and recommendations. Different standards apply in different geographical areas and industries. The following standards are the most common:

- IEC61000-3-2
- IEC61000-3-12
- IEC61000-3-4
- IEEE 519
- G5/4

See the *AHF 005/010 Design Guide* for specific details on each standard.

In Europe, the maximum THVD is 8% if the plant is connected via the public grid. If the plant has its own transformer, the limit is 10% THVD. The VLT® AQUA Drive is designed to withstand 10% THVD.

### 3.2.7.6 Harmonic Mitigation

In cases where additional harmonic suppression is required, Danfoss offers a wide range of mitigation equipment. These are:

- 12-pulse drives
- AHF filters
- Low Harmonic Drives
- Active Filters

The choice of the right solution depends on several factors:

- The grid (background distortion, mains unbalance, resonance and type of supply (transformer/generator).
- Application (load profile, number of loads and load size).
- Local/national requirements/regulations (IEEE519, IEC, G5/4, etc.).
- Total cost of ownership (initial cost, efficiency, maintenance, etc.).

Always consider harmonic mitigation if the transformer load has a non-linear contribution of 40% or more.

Danfoss offers tools for calculation of harmonics, see *chapter 2.8.2 PC Software*.

### 3.2.8 Earth Leakage Current

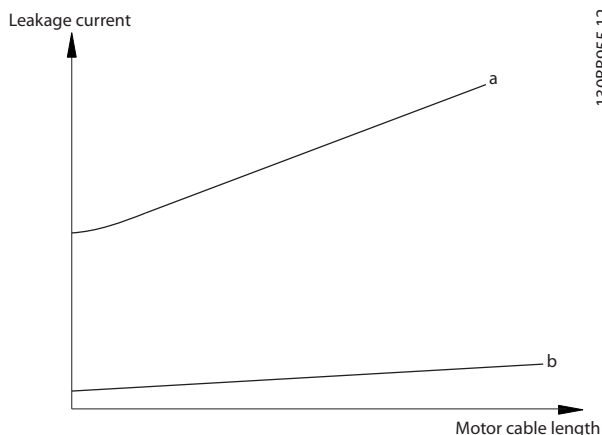
Follow national and local codes regarding protective earthing of equipment where leakage current exceeds 3.5 mA.

Frequency converter technology implies high frequency switching at high power. This generates a leakage current in the ground connection.

The earth leakage current is made up of several contributions and depends on various system configurations, including:

- RFI filtering
- Motor cable length
- Motor cable screening
- Frequency converter power

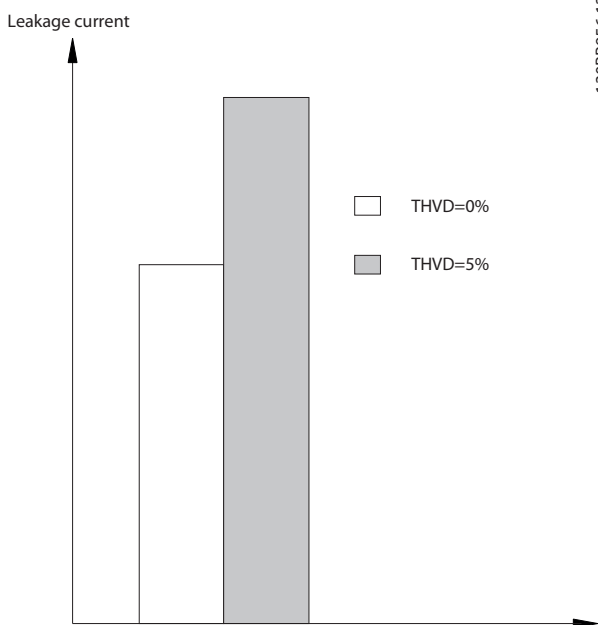
3



1308B955.12

Illustration 3.6 Motor Cable Length and Power Size Influence on Leakage Current. Powersize a > Powersize b

The leakage current also depends on the line distortion.



1308B956.12

Illustration 3.7 Line Distortion Influences Leakage Current

Compliance with EN/IEC61800-5-1 (power drive system product standard) requires special care if the leakage current exceeds 3.5 mA. Reinforce grounding with the following protective earth connection requirements:

- Ground wire (terminal 95) of at least 10 mm<sup>2</sup> cross-section.
- 2 separate ground wires both complying with the dimensioning rules.

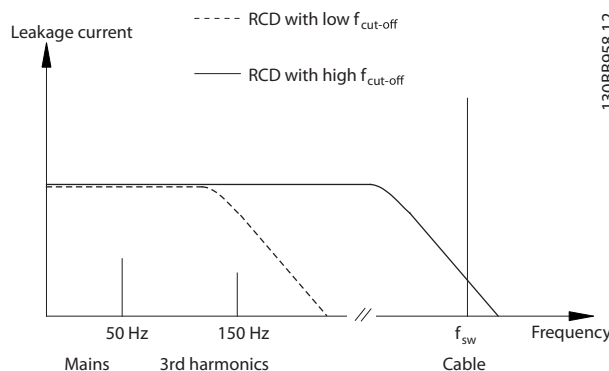
See EN/IEC61800-5-1 and EN50178 for further information.

Using RCDs

Where residual current devices (RCDs), also known as earth leakage circuit breakers (ELCBs), are used, comply with the following:

- Use RCDs of type B only as they are capable of detecting AC and DC currents.
- Use RCDs with a delay to prevent faults due to transient ground currents.
- Dimension RCDs according to the system configuration and environmental considerations.

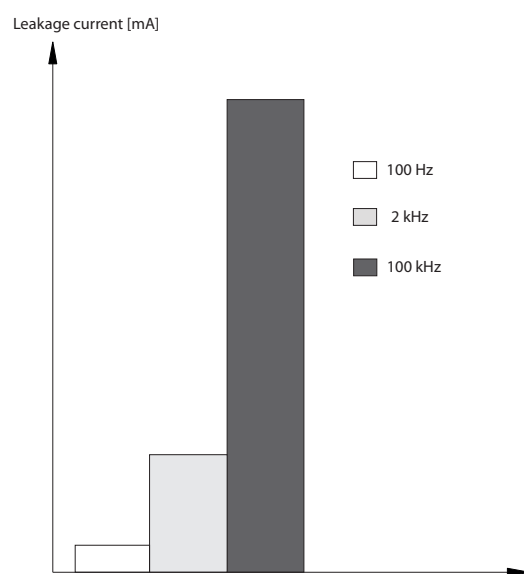
The leakage current includes several frequencies originating from both the mains frequency and the switching frequency. Whether the switching frequency is detected depends on the type of RCD used.



1308B958.12

Illustration 3.8 Main Contributions to Leakage Current

The amount of leakage current detected by the RCD depends on the cut-off frequency of the RCD.



1308B957.11

Illustration 3.9 Influence of the RCD Cut-off Frequency on Leakage Current

### 3.3 Mains Integration

#### 3.3.1 Mains Configurations and EMC Effects

There are several types of AC mains systems for supplying power to frequency converters. Each affects the EMC characteristics of the system. The 5-wire TN-S systems are regarded as best for EMC, while the isolated IT system is the least desirable.

System type	Description
TN Mains Systems	There are 2 types of TN mains distribution systems: TN-S and TN-C.
TN-S	A 5-wire system with separate neutral (N) and protective earth (PE) conductors. It provides the best EMC properties and avoids transmitting interference.
TN-C	A 4-wire system with a common neutral and protective earth (PE) conductor throughout the system. The combined neutral and protective earth conductor results in poor EMC characteristics.
TT Mains Systems	A 4-wire system with a grounded neutral conductor and individual grounding of the converter units. It has good EMC characteristics when grounded properly.
IT Mains System	An isolated 4-wire system with the neutral conductor either not grounded or grounded via an impedance.

Table 3.14 AC Mains System Types

#### 3.3.2 Low-frequency Mains Interference

##### 3.3.2.1 Non-sinusoidal Mains Supply

The mains voltage is rarely a uniform sinusoidal voltage with constant amplitude and frequency. This is partly due to loads that draw non-sinusoidal currents from the mains or have non-linear characteristics, such as computers, television sets, switching power supplies, energy-efficient lamps, and frequency converters. Deviations are unavoidable and permissible within certain limits.

##### 3.3.2.2 EMC Directives Compliance

In most of Europe, the basis for the objective assessment of the quality of mains power is the Electromagnetic Compatibility of Devices Act (EMVG). Compliance with this regulation ensures that all devices and networks connected to electrical distribution systems fulfill their intended purpose without generating problems.

Standard	Definition
EN 61000-2-2, EN 61000-2-4, EN 50160	Defines the mains voltage limits to observe in public and industrial power grids.
EN 61000-3-2, 61000-3-12	Regulates mains interference generated by connected devices.
EN 50178	Monitors electronic equipment for use in power installations.

Table 3.15 EN Design Standards for Mains Power Quality

##### 3.3.2.3 Interference-free Frequency Converters

Every frequency converter generates mains interference. Present standards only define frequency ranges up to 2 kHz. Some converters shift the mains interference in the region above 2 kHz, which is not addressed by the standard, and label them as interference-free. Limits for this region are currently being studied. Frequency converters do not shift mains interference.

##### 3.3.2.4 How Mains Interference Occurs

Mains interference distortion of the sinusoidal waveform caused by the pulsating input currents is referred to generally as harmonics. Derived from Fourier analysis, it is assessed up to 2.5 kHz, corresponding to the 50th harmonic of the mains frequency.

The input rectifiers of frequency converters generate this typical form of harmonic interference on the mains. When frequency converters are connected to 50 Hz mains systems, the 3rd harmonic (150 Hz), 5th harmonic (250 Hz) or 7th harmonic (350 Hz) show the strongest effects. The overall harmonic content is called the total harmonic distortion (THD).

##### 3.3.2.5 Effects of Mains Interference

Harmonics and voltage fluctuations are 2 forms of low-frequency mains interference. They have a different appearance at their origin than at any other point in the mains system when a load is connected. Consequently, a range of influences must be determined collectively when assessing the effects of mains interference. These include the mains feed, structure, and loads.

Undervoltage warnings and higher functional losses can occur as a result of mains interference.

###### Undervoltage warnings

- Incorrect voltage measurements due to distortion of the sinusoidal mains voltage.
- Cause incorrect power measurements because only RMS-true measuring takes harmonic content into account.

**Higher losses**

- Harmonics reduce the active power, apparent power, and reactive power.
- Distort electrical loads resulting in audible interference in other devices, or, in worst case, even destruction.
- Shorten the lifetime of devices as a result of heating.

**NOTICE**

Excessive harmonic content puts a load on power factor correction equipment and may even cause its destruction. For this reason, provide chokes for power factor correction equipment when excessive harmonic content is present.

**3.3.3 Analysing Mains Interference**

To avoid impairment of mains power quality, a variety of methods are available for analysing systems or devices that generate harmonic currents. Mains analysis programs, such as harmonic calculation software (HCS), analyse system designs for harmonics. Specific countermeasures can be tested beforehand and ensure subsequent system compatibility.

For analysing mains systems, go to <http://www.danfoss-hcs.com/Default.asp?LEVEL=START> for software download.

**NOTICE**

Danfoss has a very high level of EMC expertise and provides EMC analyses with detailed evaluation or mains calculations to customers in addition to training courses, seminars, and workshops.

**3.3.4 Options for Reducing Mains Interference**

Generally speaking, mains interference from converters is reduced by limiting the amplitude of pulsed currents. This improves the power factor  $\lambda$  (lambda).

Several methods are recommended to avoid mains harmonics:

- Input chokes or DC-link chokes in the frequency converters.
- Passive filters.
- Active filters.
- Slim DC links.
- Active front end and low harmonic drives.
- Rectifiers with 12, 18 or 24 pulses per cycle.

**3.3.5 Radio Frequency Interference**

Frequency converters generate radio frequency interference (RFI) due to their variable-width current pulses. Converters and motor cables radiate these components and conduct them into the mains system.

RFI filters are used to reduce this interference on the mains. They provide noise immunity to protect devices against high-frequency conducted interference. They also reduce interference emitted to the mains cable or radiation from the mains cable. The filters are intended to limit interference to a specified level. Built-in filters are often standard equipment rated for specific immunity.

**NOTICE**

All VLT® AQUA Drive frequency converters are equipped with integrated mains interference chokes as standard.

**3.3.6 Classification of the Operating Site**

Knowing the requirements for the environment the frequency converter is intended to operate in is the most important factor regarding EMC compliance.

**3.3.6.1 Environment 1/Class B: Residential**

Operating sites connected to the public low-voltage power grid, including light industrial areas, are classified as Environment 1/Class B. They do not have their own high-voltage or medium-voltage distribution transformers for a separate mains system. The environment classifications apply both inside and outside buildings. Some general examples are business areas, residential buildings, restaurants, car parks, and entertainment facilities.

**3.3.6.2 Environment 2/Class A: Industrial**

Industrial environments are not connected to the public power grid. Instead, they have their own high-voltage or medium-voltage distribution transformers. The environment classifications apply both inside and outside the buildings.

They are defined as industrial and are characterised by specific electromagnetic conditions:

- The presence of scientific, medical or industrial devices.
- Switching of large inductive and capacitive loads.
- The occurrence of strong magnetic fields (for example, due to high currents).

### 3.3.6.3 Special Environments

In areas with medium-voltage transformers clearly demarcated from other areas, the user decides which type of environment to classify their facility. The user is responsible for ensuring the electromagnetic compatibility necessary to enable the trouble-free operation of all devices within specified conditions. Some examples of special environments are shopping centres, supermarkets, filling stations, office buildings, and warehouses.

### 3.3.6.4 Warning Labels

When a frequency converter does not conform to Category C1, provide a warning notice. This is the responsibility of the user. Interference elimination are based on classes A1, A2, and B in EN 55011. The user is ultimately responsible for the appropriate classification of devices and the cost of remedying EMC problems.

### 3.3.7 Use with Isolated Input Source

Most utility power in the United States is referenced to earth ground. Although not in common use in the United States, the input power may be an isolated source. All Danfoss frequency converters may be used with isolated input source as well as with ground reference power lines.

### 3.3.8 Power Factor Correction

Power factor correction equipment serves to reduce the phase shift ( $\varphi$ ) between the voltage and the current to move the power factor closer to unity ( $\cos \varphi$ ). This is necessary when a large number of inductive loads, such as motors or lamp ballasts, are used in an electrical distribution system. Frequency converters with an isolated DC link do not draw any reactive power from the mains system or generate any phase power-factor correction shifts. They have a  $\cos \varphi$  of approximately 1.

For this reason, speed-controlled motors do not have to take into account when dimensioning power factor correction equipment. However, the current drawn by the phase-correction equipment rises because frequency converters generate harmonics. The load and heat factor on the capacitors increases as the number of harmonic generators increases. As a result, fit chokes in the power-factor correction equipment. The chokes also prevent resonance between load inductances and the capacitance. Converters with  $\cos \varphi < 1$  also require chokes in the power factor correction equipment. Also consider the higher reactive power level, for cable dimensions.

### 3.3.9 Input Power Delay

To ensure that the input surge suppression circuitry performs correctly, observe a time delay between successive applications of input power.

Table 3.16 shows the minimum time that must be allowed between applications of input power.

Input voltage [V]	380	415	460	600
Waiting time [s]	48	65	83	133

Table 3.16 Input Power Delay

### 3.3.10 Mains Transients

Transients are brief voltage peaks in the range of a few thousand volts. They can occur in all types of power distribution systems, including industrial and residential environments.

Lightning strikes are a common cause of transients. However, they are also caused by switching large loads on line or off, or switching other mains transients equipment, such as power factor correction equipment. Transients can also be caused by short-circuits, tripping of circuit breakers in power distribution systems, and inductive coupling between parallel cables.

EN 61000-4-1 standard describes the forms of these transients and how much energy they contain. Their harmful effects can be limited by various methods. Gas-filled surge arresters and spark gaps provide first-level protection against high-energy transients. For second-level protection, most electronic devices, including frequency converters, use voltage-dependent resistors (varistors) to attenuate transients.

### 3.3.11 Operation with a Standby Generator

Use back-up power systems, when the continued operation is necessary in the event of mains failure. They are also used in parallel with the public power grid to achieve higher mains power. This is common practice for combined heat and power units, taking advantage of the high efficiency achieved with this form of energy conversion. When back-up power is provided by a generator, the mains impedance is usually higher than when power is taken from the public grid. This causes the total harmonic distortion to increase. With proper design, generators can operate in a system containing devices that induce harmonics.

System design consideration with a stand-by generator is recommended.

- When the system is switched from mains operation to generator, the harmonic load usually increases.
- Designers must calculate or measure the increase in the harmonic load to ensure that the power quality conforms to regulations to prevent harmonic problems and equipment failure.
- Avoid asymmetric loading of the generator must be avoided since it causes increased losses and may increase total harmonic distortion.
- A 5/6 stager of the generator winding attenuates the 5th and 7th harmonics, but it allows the 3rd harmonic to increase. A 2/3 stager reduces the 3rd harmonic.
- When possible, the operator should disconnect power factor correction equipment because it causes resonance in the system.
- Chokes or active absorption filters can attenuate harmonics as well as resistive loads operated in parallel.
- Capacitive loads operated in parallel create an additional load due to unpredictable resonance effects.

A more precise analysis is possible using mains analysis software, such as HCS. For analysing mains systems, go to <http://www.danfoss-hcs.com/Default.asp?LEVEL=START> for software download.

When operating with harmonic-inducing devices, the maximum loads based on trouble-free facility operation are shown in the harmonic limits table.

#### Harmonic limits

- B2 and B6 rectifiers⇒maximum 20% of rated generator load.
- B6 rectifier with choke⇒maximum 20–35% of rated generator load, depending on the composition.
- Controlled B6 rectifier⇒maximum 10% of rated generator load.

## 3.4 Motor Integration

### 3.4.1 Motor Selection Considerations

The frequency converter can induce electrical stress on a motor. Consider, therefore, the following effects on the motor when matching motor with frequency converter:

- Insulation stress
- Bearing stress
- Thermal stress

### 3.4.2 Sine-wave and dU/dt Filters

Output filters provide benefits to some motors to reduce electrical stress and allow for longer cable length. Output options include sine-wave filters (also called LC filters) and dU/dt filters. The dU/dt filters reduce the sharp rise rate of the pulse. Sine-wave filters smooth the voltage pulses to convert them into a nearly sinusoidal output voltage. With some frequency converters, sine-wave filters comply with EN 61800-3 RFI category C2 for unshielded motor cables, see *chapter 3.7.5 Sine-wave Filters*.

For more information on sine-wave and dU/dt filter options, refer to *chapter 3.7.5 Sine-wave Filters* and *chapter 3.7.6 dU/dt Filters*.

For more information on sine-wave and dU/dt filter ordering numbers, refer to and *chapter 6.2.9 dU/dt Filters*.

### 3.4.3 Proper Motor Grounding

Proper grounding of the motor is imperative for personal safety and to meet EMC electrical requirements for low voltage equipment. Proper grounding is necessary for the effective use of shielding and filters. Design details must be verified for proper EMC implementation.

### 3.4.4 Motor Cables

Motor cable recommendations and specifications are provided in *chapter 7.5 Cable Specifications*.

All types of 3-phase asynchronous standard motors can be used with a frequency converter unit. The factory setting is for clockwise rotation with the frequency converter output connected as follows.



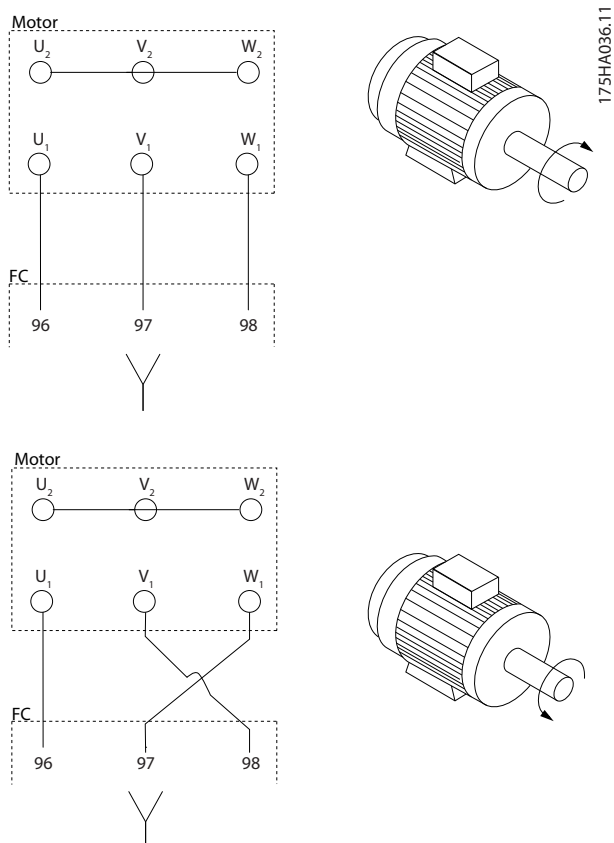


Illustration 3.10 Terminal Connection for Clockwise and Counter-clockwise Rotation

Change the direction of rotation by switching 2 phases in the motor cable or by changing the setting of 4-10 Motor Speed Direction.

### 3.4.5 Motor Cable Shielding

Frequency converters generate steep-edged pulses on their outputs. These pulses contain high-frequency components (extending into the gigahertz range), which cause undesirable radiation from the motor cable. Shielded motor cables reduce this radiation.

The purposes of shielding are to:

- Reduce the magnitude of radiated interference.
- Improve the interference immunity of individual devices.

The shield captures the high-frequency components and conducts them back to the interference source, in this case the frequency converter. Shielded motor cables also provide immunity to interference from nearby external sources.

Even good shielding does not fully eliminate the radiation. System components located in radiation environments must operate without degradation.

### 3.4.6 Connection of Multiple Motors

#### NOTICE

Problems may arise at start and at low RPM values if motor sizes are widely different because small motors' relatively high ohmic resistance in the stator calls for a higher voltage at start and at low RPM values.

The frequency converter can control several parallel-connected motors. When using parallel motor connection, observe the following:

- VCC<sup>+</sup> mode may be used in some applications.
- The total current consumption of the motors must not exceed the rated output current  $I_{INV}$  for the frequency converter.
- Do not use common joint connection for long cable lengths, see *Illustration 3.12*.
- The total motor cable length specified in *Table 3.4*, is valid as long as the parallel cables are kept short (less than 10 m each), see *Illustration 3.14* and *Illustration 3.15*.
- Consider voltage drop across the motor cable, see *Illustration 3.15*.
- For long parallel cables, use an LC filter, see *Illustration 3.15*.
- For long cables without parallel connection, see *Illustration 3.16*.

#### NOTICE

When motors are connected in parallel, set 1-01 Motor Control Principle to [0] U/f.

3

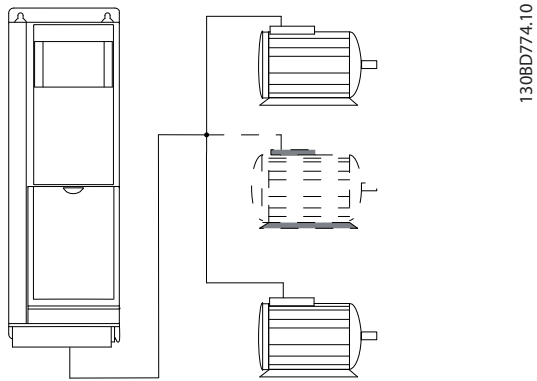


Illustration 3.11 Common Joint Connection for Short Cable Lengths

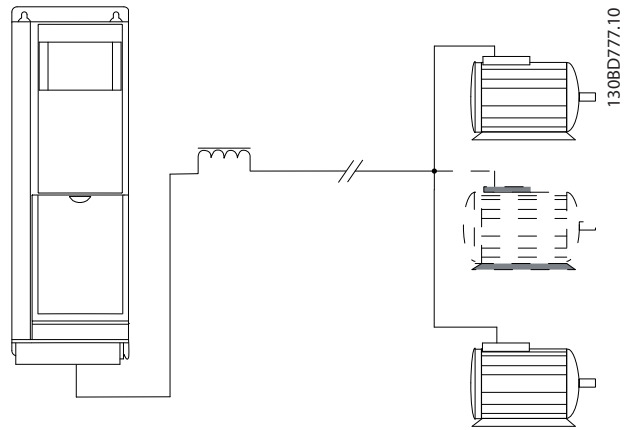


Illustration 3.14 Parallel Cables with Load

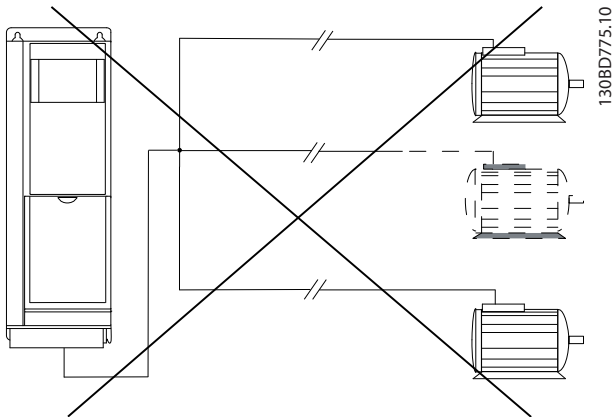


Illustration 3.12 Common Joint Connection for Long Cable Lengths

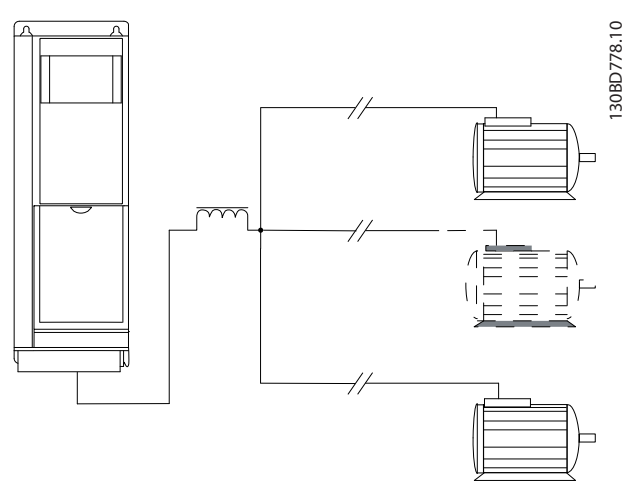


Illustration 3.15 LC Filter for Long Parallel Cables

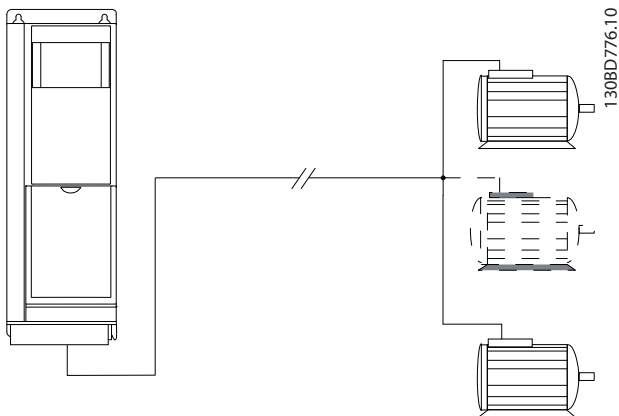


Illustration 3.13 Parallel Cables without Load

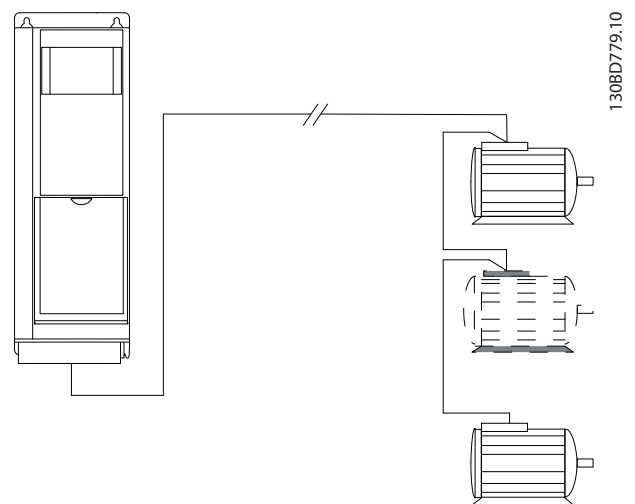


Illustration 3.16 Long Cables in Series Connection

Enclosure sizes	Power Size [kW]	Voltage [V]	1 cable [m]	2 cables [m]	3 cables [m]	4 cables [m]
A1, A2, A4, A5	0.37–0.75	400	150	45	8	6
		500	150	7	4	3
A2, A4, A5	1.1–1.5	400	150	45	20	8
		500	150	45	5	4
A2, A4, A5	2.2–4	400	150	45	20	11
		500	150	45	20	6
A3, A4, A5	5.5–7.5	400	150	45	20	11
		500	150	45	20	11
B1, B2, B3, B4, C1, C2, C3, C4	11–90	400	150	75	50	37
		500	150	75	50	37
A3	1.1–7.5	525–690	100	50	33	25
B4	11–30	525–690	150	75	50	37
C3	37–45	525–690	150	75	50	37

Table 3.17 Maximum Cable Length for Each Parallel Cable

### 3.4.7 Control Wire Isolation

Harmonic interference generated by motor cabling can degrade control signals in the converter control wiring and result in control faults. Motor cables and control wiring should be separate. Interference effects decrease significantly with separation.

- The distance between control wiring and motor cables should be more than 200 mm.
- Divider strips are essential with smaller separations or interference may be coupled in or transferred.
- Control cable shields must be connected at both ends in the same way as motor cable shields.
- Shielded cables with twisted conductors provide highest attenuation. The attenuation of the magnetic field increases from around 30 dB with a single shield to 60 dB with a double shield and to approximately 75 dB if the conductors are also twisted.

### 3.4.8 Motor Thermal Protection

The frequency converter provides motor thermal protection in several ways:

- Torque limit protects the motor from overload independent of the speed.
- Minimum speed limits the minimum operating speed range, for instance between 30 and 50/60 Hz.
- Maximum speed limits the maximum output speed.
- Input is available for an external thermistor.

- Electronic thermal relay (ETR) for asynchronous motors simulates a bi-metal relay based on internal measurements. The ETR measures actual current, speed and time to calculate motor temperature and protect the motor from being overheated by issuing a warning or cutting power to the motor. The characteristics of the ETR are shown in *Illustration 3.17*.

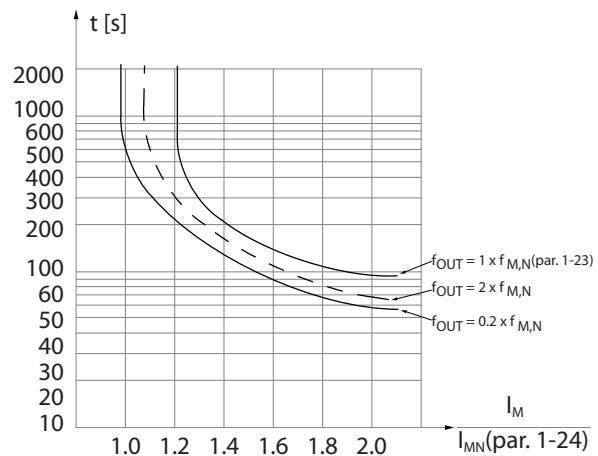


Illustration 3.17 Electronic Thermal Relay Characteristics

The X-axis shows the ratio between  $I_{motor}$  and  $I_{motor}$  nominal. The Y-axis shows the time in seconds before the ETR cut off and trip. The curves show the characteristic nominal speed, at twice the nominal speed and at 0.2 x the nominal speed.

At lower speed, the ETR cuts off at lower heat due to less cooling of the motor. In that way, the motor is protected from overheating even at low speed. The ETR feature calculates the motor temperature based on actual current and speed.

### 3.4.9 Output Contactor

Although not generally a recommended practice, operating an output contactor between the motor and the frequency converter does not cause damage to the frequency converter. Closing a previously opened output contactor may connect a running frequency converter to a stopped motor. This may cause the frequency converter to trip and display a fault.

### 3.4.10 Brake Functions

To brake the load on the motor shaft, use either a static (mechanical) or dynamic brake.

### 3.4.11 Dynamic Braking

Dynamic brake is established by the following:

- Resistor brake: A brake IGBT keeps the overvoltage below a prescribed threshold by directing brake energy from the motor to the brake resistor.
- AC brake: The brake energy is distributed in the motor by changing the loss conditions in the motor. The AC brake function cannot be used in applications with high cycling frequency since this will overheat the motor.
- DC brake: An over-modulated DC current added to the AC current works as an eddy-current brake.

### 3.4.12 Brake Resistor Calculation

A brake resistor is required to manage heat dissipation and DC-link voltage increase during electrically-generated braking. Using a brake resistor ensures that the energy is absorbed in the brake resistor and not in the frequency converter. For more information see the *Brake Resistor Design Guide*.

#### Duty cycle calculation

When the amount of kinetic energy transferred to the resistor in each braking period is unknown, calculate the average power on the basis of the cycle time and braking time (known as the intermittent duty cycle). The resistor intermittent duty cycle is an indication of the cycle when the resistor is active (see *Illustration 3.18*). Motor suppliers often use S5 when stating the permissible load, which is an expression of intermittent duty cycle.

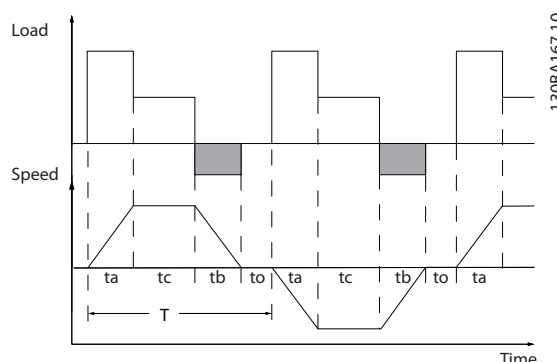


Illustration 3.18 Brake Resistor Duty Cycle

Calculate the intermittent duty cycle for the resistor as follows:

$$\text{Duty cycle} = t_b / T$$

T = cycle time in seconds

t<sub>b</sub> is the braking time in seconds (of the cycle time)

Danfoss offers brake resistors with duty cycles of 5%, 10%, and 40%. When a 10% duty cycle is applied, the brake resistors absorb brake power for 10% of the cycle time. The remaining 90% of the cycle time is used to dissipate excess heat.

Ensure the brake resistor is dimensioned for the required braking time.

#### Brake resistance calculation

To prevent the frequency converter from cutting out for protection when the motor brakes, select resistor values on the basis of the peak braking power and the intermediate circuit voltage. Calculate resistance of the brake resistor as follows:

$$R_{br} = \frac{U_{dc}^2}{P_{peak}} [\Omega]$$

The brake resistor performance depends on the DC-link voltage (U<sub>dc</sub>).

U<sub>dc</sub> is the voltage at which the brake is activated. The FC-series brake function is settled depending on the mains supply.

Mains supply input [V AC]	Brake active [V DC]	High voltage warning [V DC]	Over voltage alarm [V DC]
FC 202 3x200-240	390	405	410
FC 202 3x380-480	778	810	820
FC 202 3x525-600 <sup>1)</sup>	943	965	975
FC 202 3x525-600 <sup>2)</sup>	1099	1109	1130
FC 202 3x525-690	1099	1109	1130

Table 3.18 DC-link Voltage (U<sub>dc</sub>)

1) Enclosure sizes A, B, C

2) Enclosure sizes D, E, F

Use the brake resistance  $R_{rec}$ , to ensure that the frequency converter is able to brake at the highest braking torque ( $M_{br(\%)}$ ) of 160%. The formula can be written as:

$$R_{rec} [\Omega] = \frac{U_{dc}^2 \times 100}{P_{motor} \times M_{br}(\%) \times \eta_{VLT} \times \eta_{motor}}$$

$\eta_{motor}$  is typically at 0.90

$\eta_{VLT}$  is typically at 0.98

When a higher brake resistor resistance is selected, 160%/150%/110% braking torque cannot be obtained, and there is a risk that the frequency converter cuts out of DC-Link overvoltage for protection.

For braking at lower torque, for example 80% torque, it is possible to install a brake resistor with lower power rating. Calculate size using the formula for calculating  $R_{rec}$ .

Frequency converter D and F enclosure sizes contain more than one brake chopper. Use a brake resistor for each chopper for those enclosure sizes.

The *VLT® Brake Resistor MCE 101 Design Guide* contains the most up-to-date selection data, and describes the calculation steps in more detail, including:

- Calculation of braking power
- Calculation of brake resistor peak power
- Calculation of brake resistor average power
- Braking of inertia

### 3.4.13 Brake Resistor Cabling

#### EMC (twisted cables/shielding)

To meet the specified EMC performance of the frequency converter, use screened cables/wires. If unscreened wires are used, it is recommended to twist the wires to reduce the electrical noise from the wires between the brake resistor and the frequency converter.

For enhanced EMC performance, use a metal screen.

### 3.4.14 Brake Resistor and Brake IGBT

#### Brake resistor power monitor

In addition, the brake power monitor function makes it possible to read out the momentary power and the mean power for a selected time period. The brake can also monitor the power energising and make sure it does not exceed a limit selected in *2-12 Brake Power Limit (kW)*. In *2-13 Brake Power Monitoring*, select the function to carry out when the power transmitted to the brake resistor exceeds the limit set in *2-12 Brake Power Limit (kW)*.

## NOTICE

**Monitoring the brake power does not fulfil a safety function. The brake resistor circuit is not ground leakage protected.**

The brake is protected against short-circuiting of the brake resistor, and the brake transistor is monitored to ensure that short-circuiting of the transistor is detected. Use a relay or digital output to protect the brake resistor against overloading in the event of a fault in the frequency converter.

*Overvoltage control (OVC)* can be selected as an alternative brake function in *2-17 Over-voltage Control*. If the DC-link voltage increases, this function is active for all units. The function ensures that a trip can be avoided. This is done by increasing the output frequency to limit the voltage from the DC link. It is a useful function, e.g. if the ramp-down time is too short since tripping of the frequency converter is avoided. In this situation the ramp-down time is extended.

### 3.4.15 Energy Efficiency

#### Efficiency of the frequency converter

The load on the frequency converter has little effect on its efficiency.

This also means that the frequency converter efficiency does not change when other U/f characteristics are selected. However, the U/f characteristics do influence the efficiency of the motor.

The efficiency declines a little when the switching frequency is set to a value above 5 kHz. The efficiency is also slightly reduced when the motor cable is longer than 30 m.

#### Efficiency calculation

Calculate the efficiency of the frequency converter at different loads based on *Illustration 3.19*. Multiply the factor in this graph with the specific efficiency factor listed in *chapter 7.1 Electrical Data*.

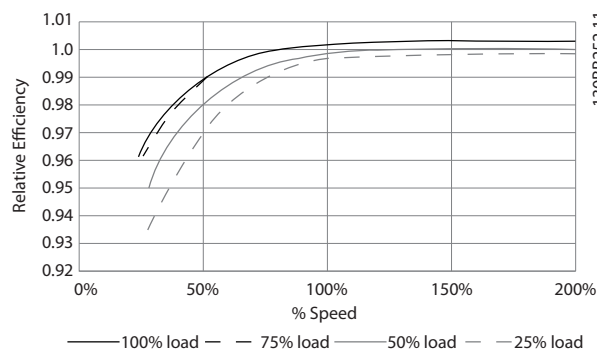


Illustration 3.19 Typical Efficiency Curves

Example: Assume a 55 kW, 380-480 V AC frequency converter with 25% load at 50% speed. The graph is showing 0.97 rated efficiency for a 55 kW frequency converter is 0.98. The actual efficiency is then:  $0.97 \times 0.98 = 0.95$ .

#### Motor efficiency

The efficiency of a motor connected to the frequency converter depends on magnetising level. The efficiency of the motor depends on the type of motor.

- In the range of 75-100% of the rated torque, the efficiency of the motor is practically constant, both when it is controlled by the frequency converter and when it runs directly on mains.
- The influence from the U/f characteristic on small motors is marginal. However, in motors from 11 kW and up, the efficiency advantage is significant.
- The switching frequency does not affect the efficiency of small motors. Motors from 11 kW and up have their efficiency improved 1-2%. This is because the sine-shape of the motor current is almost perfect at high switching frequency.

#### System efficiency

To calculate the system efficiency, multiply the efficiency of the frequency converter by the efficiency of the motor.

### 3.5 Additional Inputs and Outputs

#### 3.5.1 Wiring Schematic

When wired and properly programmed, the control terminals provide:

- Feedback, reference, and other input signals to the frequency converter.
- Output status and fault conditions from the frequency converter.
- Relays to operate auxiliary equipment.
- A serial communication interface.
- 24 V common.

Control terminals are programmable for various functions by selecting parameter options through the local control panel (LCP) on the front of the unit or external sources. Most control wiring is customer-supplied, unless specified in the factory order.

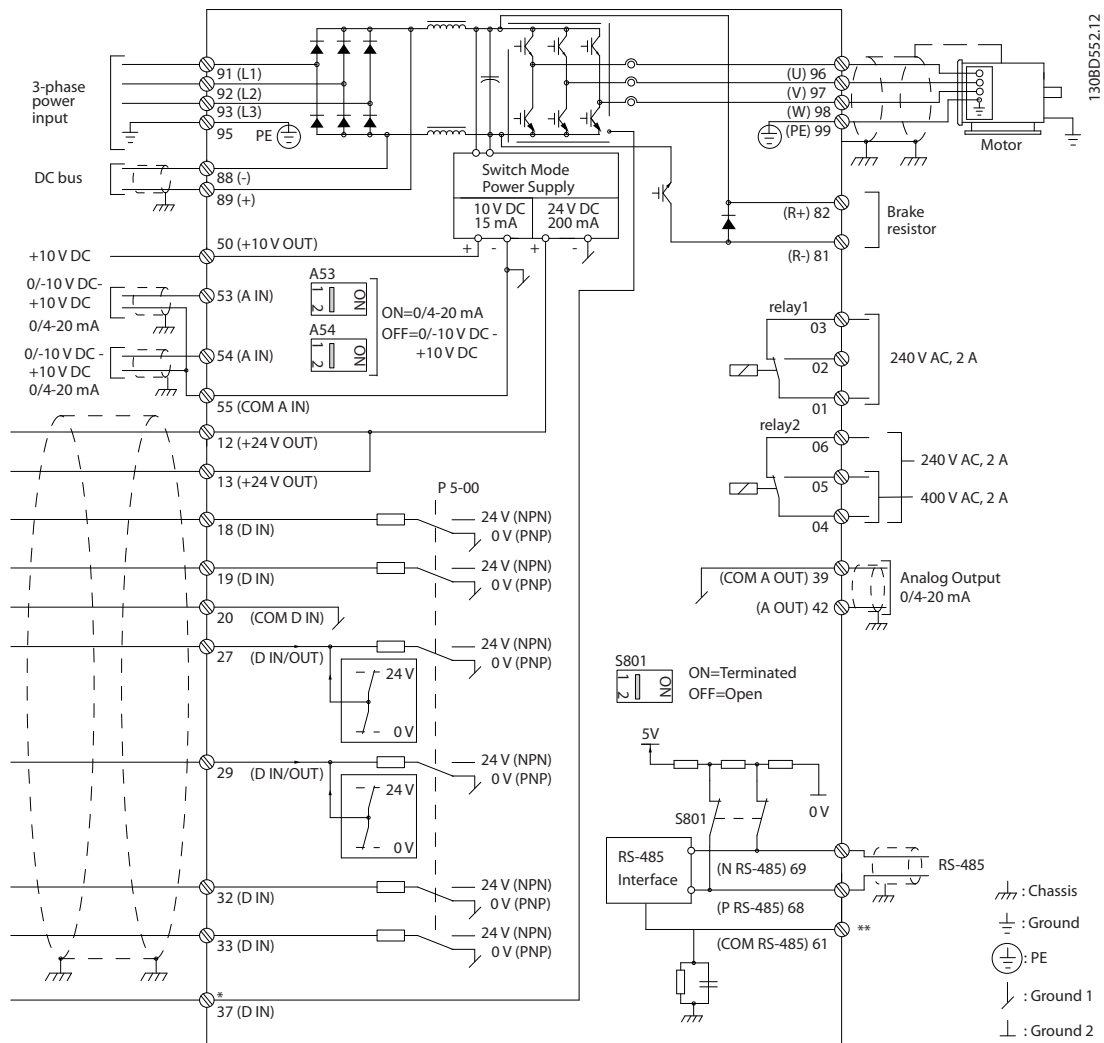


Illustration 3.20 Basic Wiring Schematic

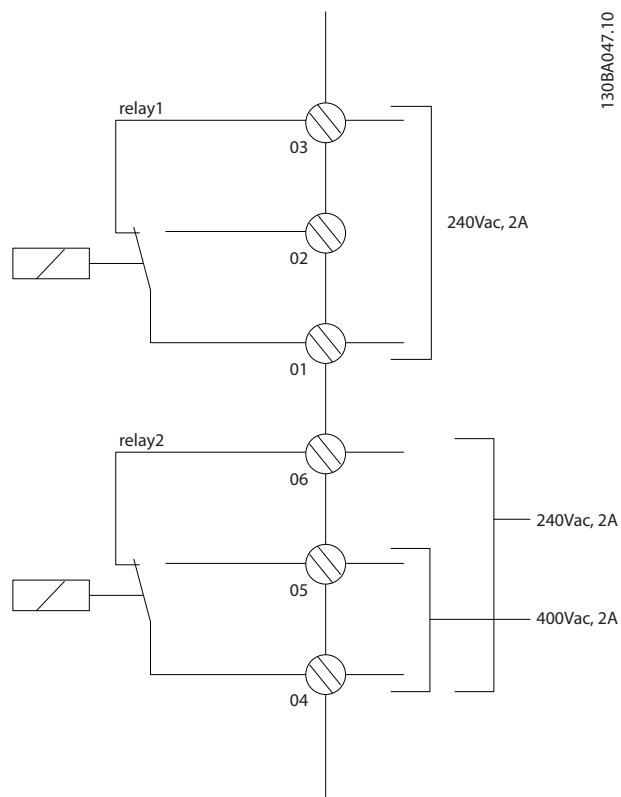
A=Analog, D=Digital

\*Terminal 37 (optional) is used for STO. For STO installation instructions, refer to the *VLT® Safe Torque Off Operating Instructions*.

\*\*Do not connect cable screen.

3

### 3.5.2 Relay Connections



130BA047.10

For more information about relays, refer to *chapter 7 Specifications* and *chapter 8.3 Relay Terminal Drawings*.

For more information about relay options, refer to *chapter 3.7 Options and Accessories*.

Relay	Terminal <sup>1)</sup>	Description
1	1	common
	2	normally open maximum 240 V
	3	normally closed maximum 240 V
2	4	common
	5	normally closed maximum 240 V
	6	normally closed maximum 240 V
1	01-02	make (normally open)
	01-03	break (normally closed)
2	04-05	make (normally open)
	04-06	break (normally closed)

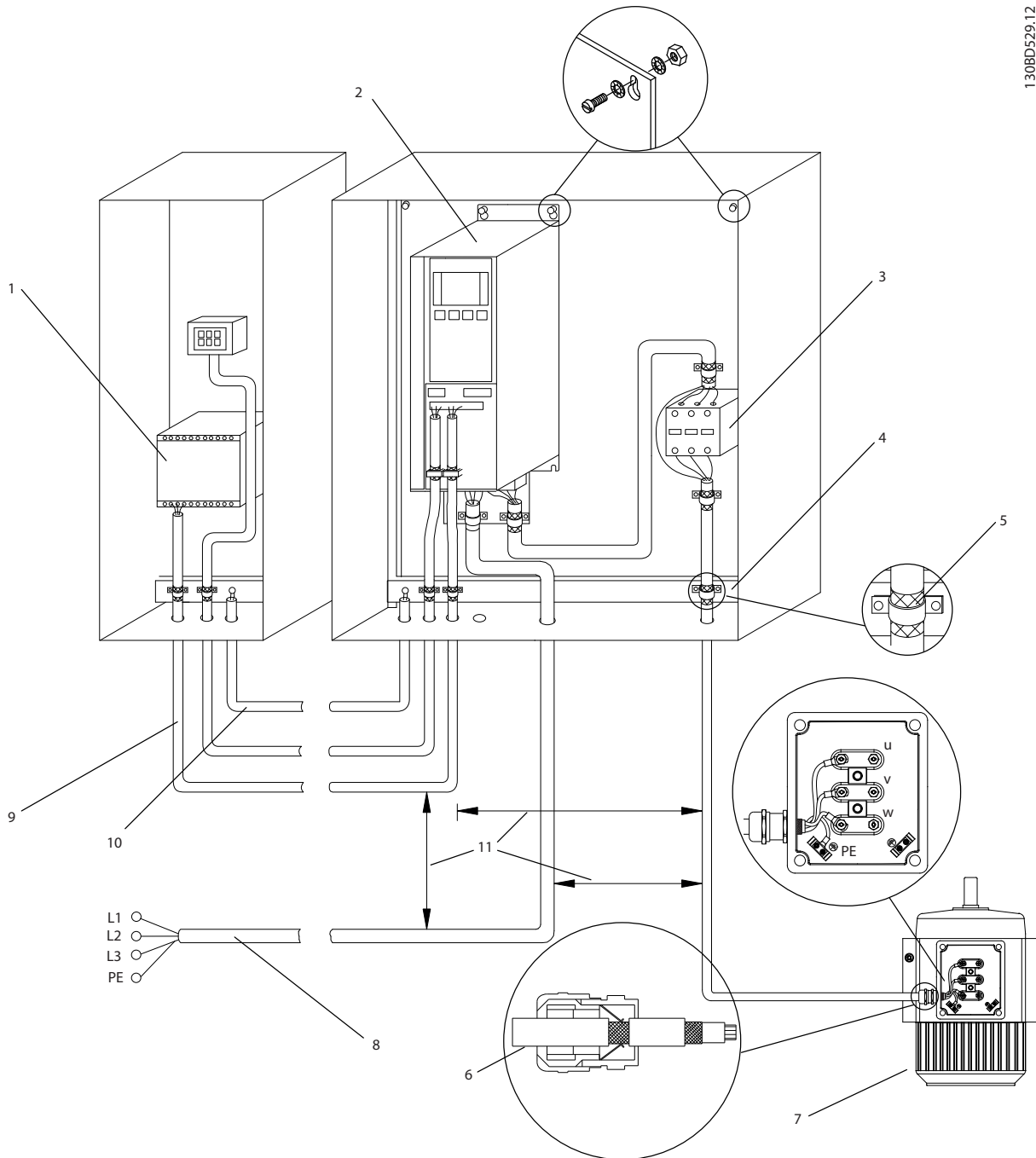
Illustration 3.21 Relay Outputs 1 and 2, Maximum Voltages

1) To add more relay outputs, install VLT<sup>®</sup> Relay Option Module MCB 105 or VLT<sup>®</sup> Relay Option Module MCB 113.



3.5.3 EMC-compliant Electrical Connection

130BD529.12



1	PLC	7	Motor, 3-phase and PE (screened)
2	Frequency converter	8	Mains, 3-phase and reinforced PE (not screened)
3	Output contactor	9	Control wiring (screened)
4	Cable clamp	10	Potential equalisation min. 16 mm <sup>2</sup> (0.025 in)
5	Cable insulation (stripped)	11	Clearance between control cable, motor cable and mains cable: Minimum 200 mm
6	Cable gland		

Illustration 3.22 EMC-compliant Electrical Connection

For more information about EMC, see *chapter 2.5.18 EMC Compliance* and *chapter 3.2 EMC, Harmonics and Earth Leakage Protection*.

**NOTICE**

**EMC INTERFERENCE**

Use screened cables for motor and control wiring, and separate cables for input power, motor wiring and control wiring. Failure to isolate power, motor, and control cables can result in unintended behaviour or reduced performance. Minimum 200 mm (7.9 in.) clearance between power, motor, and control cables is required.

3

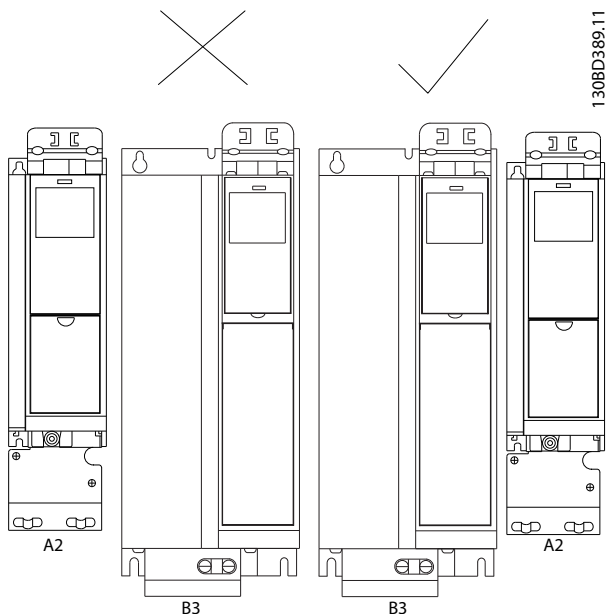
**3.6 Mechanical Planning**

**3.6.1 Clearance**

Side-by-side installation is suitable for all enclosure sizes, except when an IP21/IP4X/TYPE 1 enclosure kit is used (see *chapter 3.7 Options and Accessories*).

**Horizontal clearance, IP20**

IP20 A and B enclosure sizes can be arranged side-by-side with no clearance. However the correct mounting order is important. *Illustration 3.23* shows how to mount correctly.



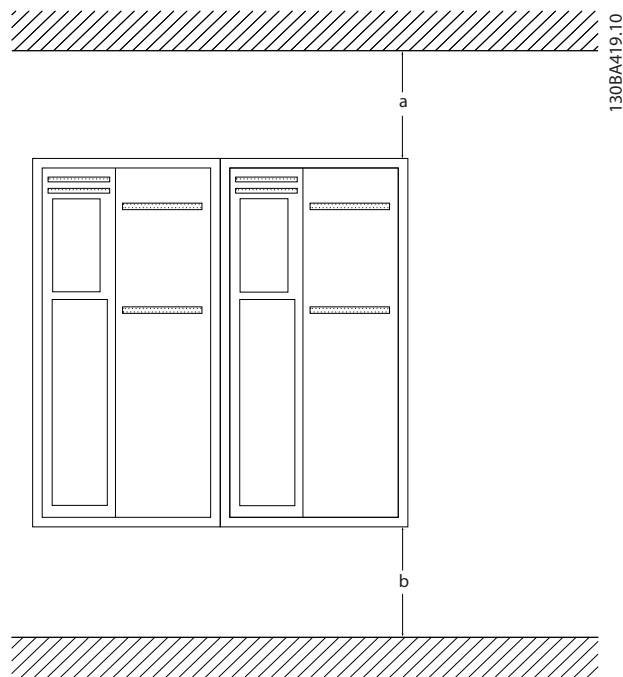
**Illustration 3.23 Correct Side-by-side Mounting with no Clearance**

**Horizontal clearance, IP21 enclosure kit**

When the IP21 enclosure kit is used on enclosure sizes A1, A2 or A3, ensure a clearance between the frequency converters of minimum 50 mm.

**Vertical clearance**

For optimal cooling conditions, ensure vertical clearance for free air passage above and below the frequency converter. See *Illustration 3.24*.



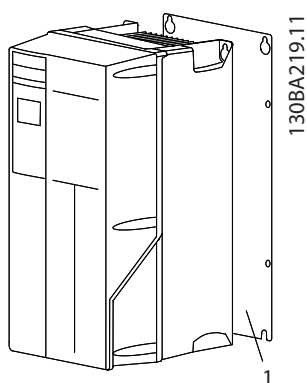
Enclosure size	A1*/A2/A3/A4/A5/B1	B2/B3/B4/C1/C3	C2/C4
a [mm]	100	200	225
b [mm]	100	200	225

**Illustration 3.24 Vertical Clearance**

### 3.6.2 Wall Mounting

When mounting on a flat wall, no back plate is required.

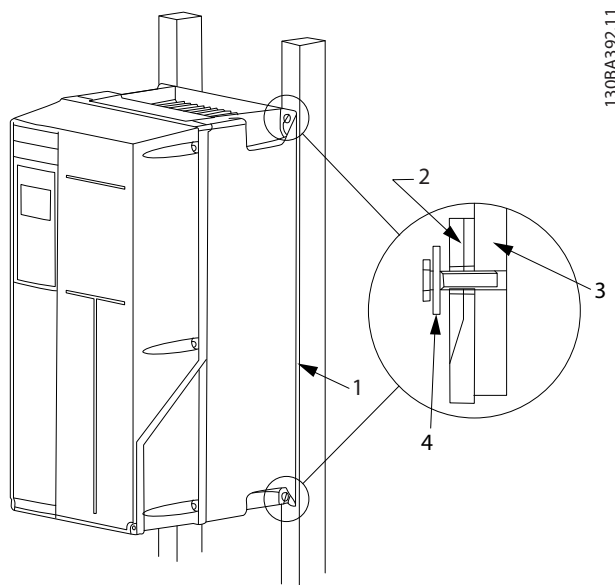
When mounting on an uneven wall, use a back plate to ensure sufficient cooling air over the heat sink. Use the back plate with enclosures A4, A5, B1, B2, C1 and C2 only.



1	Back plate
---	------------

Illustration 3.25 Mounting with Back Plate

For frequency converters with protection rating IP66, use a fibre or nylon washer to protect the epoxy coating.



1	Back plate
2	Frequency converter with IP66 enclosure
3	Back plate
4	Fibre washer

Illustration 3.26 Mounting with Back Plate for Protection Rating IP66

### 3.6.3 Access

To plan accessibility for cabling before mounting, refer to the drawings in *chapter 8.1 Mains Connection Drawings (3-phases)* and *chapter 8.2 Motor Connection Drawings*.

## 3.7 Options and Accessories

### Options

For ordering numbers, see *chapter 6 Typecode and Selection*

#### Mains shielding

- Lexan® shielding mounted in front of incoming power terminals and input plate to protect from accidental contact when the enclosure door is open.
- Space heaters and thermostat: Mounted on the cabinet interior of F frames, space heaters controlled via automatic thermostat prevents condensation inside the enclosure. The thermostat default settings turn on the heaters at 10 °C (50 °F) and turn them off at 15.6 °C (60 °F).

#### RFI filters

- Frequency converter feature integrated Class A2 RFI filters as standard. If additional levels of RFI/EMC protection are required, they can be obtained using optional Class A1 RFI filters, which provide suppression of radio frequency interference and electromagnetic radiation in accordance with EN 55011.

#### Residual current device (RCD)

Uses the core balance method to monitor ground fault currents in grounded and high-resistance grounded systems (TN and TT systems in IEC terminology). There is a pre-warning (50% of main alarm set-point) and a main alarm set-point. Associated with each setpoint is an SPDT alarm relay for external use, which requires an external *window-type* current transformer (supplied and installed by the customer).

- Integrated into the frequency converter's safe torque off circuit
- IEC 60755 Type B device monitors, pulsed DC, and pure DC ground fault currents
- LED bar graph indicator of the ground fault current level from 10-100% of the setpoint
- Fault memory
- TEST/RESET key

**Insulation resistance monitor (IRM)**

Monitors the insulation resistance in ungrounded systems (IT systems in IEC terminology) between the system phase conductors and ground. There is an ohmic pre-warning and a main alarm setpoint for the insulation level.

Associated with each setpoint is an SPDT alarm relay for external use. Note: Only one insulation resistance monitor can be connected to each ungrounded (IT) system.

- Integrated into the frequency converter's safe-stop circuit
- LCD display of insulation resistance
- Fault memory
- INFO, TEST, and RESET keys

**Brake chopper (IGBTs)**

- Brake terminals with an IGBT brake chopper circuit allow for the connection of external brake resistors. For more information on brake resistors, refer to *chapter 3.4.12 Brake Resistor Calculation* and .

**Regeneration terminals**

- These terminals allow connection of regeneration units to the DC bus on the capacitor bank side of the DC-link reactors for regenerative braking. The F-frame regeneration terminals are sized for approximately ½ the power rating of the frequency converter. Consult the factory for regeneration power limits based on the specific frequency converter size and voltage

**Load sharing terminals**

- These terminals connect to the DC bus on the rectifier side of the DC link reactor and allow for the sharing of DC bus power among multiple drives. The F-frame load sharing terminals are sized for approximately 1/3 the power rating of the frequency converter. Consult the factory for load sharing limits based on the specific frequency converter size and voltage.

**Fuses**

- Fuses are recommended for fast-acting current overload protection of the frequency converter. Fuse protection limits frequency converter damage and minimises service time in the event of a failure. Fuses are required to meet marine certification.

**Disconnect**

- A door-mounted handle allows for the manual operation of a power disconnect switch to enable and disable power to the frequency converter, increasing safety during servicing. The disconnect is interlocked with the enclosure doors to prevent them from being opened while power is still applied.

**Circuit breakers**

- A circuit breaker can be remotely tripped but must be manually reset. Circuit breakers are interlocked with the enclosure doors to prevent them from being opened while power is still applied. When a circuit breaker is ordered as an option, fuses are also included for fast-acting current overload protection of the frequency converter.

**Contactors**

- An electrically controlled contactor switch allows for the remote enabling and disabling of power to the frequency converter. If the IEC emergency stop option is ordered, the Pilz Safety monitors an auxiliary contact on the contactor.

**Manual motor starters**

Provide 3-phase power for electric cooling blowers often required for larger motors. Power for the starters is provided from the load side of any supplied contactor, circuit breaker, or disconnect switch and from the input side of the Class 1 RFI filter (optional). Power is fused before each motor starter, and is off when the incoming power to the frequency converter is off. Up to two starters are allowed (one if a 30-amp, fuse-protected circuit is ordered). Integrated into the frequency converter's safe torque off circuit.

Unit features include:

- Operation switch (on/off).
- Short-circuit and overload protection with test function.
- Manual reset function.

**30 Amp, fuse-protected terminals**

- 3-phase power matching incoming mains voltage for powering auxiliary customer equipment.
- Not available if 2 manual motor starters are selected.
- Terminals are off when the incoming power to the frequency converter is off.
- Power for the fused-protected terminals is provided from the load side of any supplied contactor, circuit breaker, or disconnect switch and from the input side of the Class 1 RFI filter (optional).

**24 V DC power supply**

- 5 Amp, 120 W, 24 V DC.
- Protected against output overcurrent, overload, short-circuits, and overtemperature.
- For powering customer-supplied accessory devices such as sensors, PLC I/O, contactors, temperature probes, indicator lights, and/or other electronic hardware.

- Diagnostics include a dry DC-ok contact, a green DC-ok LED, and a red overload LED.

#### External temperature monitoring

- Designed for monitoring temperatures of external system components, such as the motor windings and/or bearings. Includes 8 universal input modules plus 2 dedicated thermistor input modules. All 10 modules are integrated into the frequency converter's safe torque off circuit and can be monitored via a fieldbus network (requires the purchase of a separate module/bus coupler). Order a safe torque off brake option to select external temperature monitoring.

#### Serial communications

##### PROFIBUS DP V1 MCA 101

- PROFIBUS DP V1 gives wide compatibility, a high level of availability, support for all major PLC vendors, and compatibility with future versions.
- Fast, efficient communication, transparent installation, advanced diagnosis and parameterisation and auto-configuration of process data via GSD-file.
- A-cyclic parameterisation using PROFIBUS DP V1, PROFIdrive or Danfoss FC profile state machines, PROFIBUS DP V1, Master Class 1 and 2 Ordering number 130B1100 uncoated – 130B1200 coated (Class G3/ISA S71.04-1985).

##### DeviceNet MCA 104

- This modern communications model offers key capabilities that allow operators effectively determine what information is needed and when.
- It benefits from ODVA's strong conformance testing policies, which ensure that products are interoperable. Ordering number 130B1102 uncoated 130B1202 coated (Class G3/ISA S71.04-1985).

##### PROFINET RT MCA 120

The PROFINET option offers connectivity to PROFINET-based networks via the PROFINET protocol. The option is able to handle a single connection with an actual packet interval down to 1 ms in both directions.

- Built-in web server for remote diagnosis and reading out of basic frequency converter parameters.
- An e-mail notification can be configured for sending an e-mail message to one or several receivers, if certain warnings or alarms occur, or have cleared again.
- TCP/IP for easy access to frequency converter configuration data from MCT 10 Set-up Software.
- FTP (File Transfer Protocol) file uploaded and download.

- Support of DCP (discovery and configuration protocol).

##### EtherNet IP MCA 121

EtherNet becomes the future standard for communication on the factory floor. The EtherNet option is based on the newest technology available for the Industrial use and handles even the most demanding requirements. EtherNet/IP extends commercial off-the-shelf EtherNet to the common industrial protocol (CIP™) the same upper-layer protocol and object model found in DeviceNet. The MCA 121 offers advanced features as:

- Built-in high performance switch enabling line-topology, and eliminating the need for external switches.
- Advanced switch and diagnosis functions.
- A built-in web server.
- An e-mail client for service notification.

##### Modbus TCP MCA 122

The Modbus option offers connectivity to Modbus TCP-based networks, such as Groupe Schneider PLC system via the Modbus TCP Protocol. The option is able to handle a single connection with an actual packet interval down to 5 ms in both directions.

- Built-in web-server for remote diagnosis and reading out basic frequency converter parameters.
- An e-mail notification can be configured for sending an e-mail message to one or several receivers, if certain warnings or alarms occur, or have cleared again.
- 2 ethernet ports with built-in switch.
- FTP (file transfer protocol) file uploaded and download.
- Protocol automatic IP address configuration.

#### More Options

##### General purpose I/O MCB 101

The I/O option offers an extended number of control inputs and outputs.

- 3 digital inputs 0–24 V: Logic 0<5 V; Logic 1>10 V
- 2 analog inputs 0–10 V: Resolution 10 bit plus sign
- 2 digital outputs NPN/PNP push pull
- 1 analog output 0/4–20 mA
- Spring-loaded connection
- Separate parameter settings Ordering number 130B1125 uncoated – 130B1212 coated (Class G3/ISA S71.04-1985)

##### Relay option MCB 105

Enables to extend relay functions with 3 additional relay outputs.

- Maximum terminal load: AC-1 resistive load: 240 V AC 2 A AC-15
- Inductive load @cos  $\phi$  0.4: 240 V AC 0.2 A DC-1
- Resistive load: 24 V DC 1 A DC-13
- Inductive load: @cos  $\phi$  0.4: 24 V DC 0.1 A
- Minimum terminal load: DC 5 V: 10 mA
- Maximum switch rate at rated load/min. load: 6 min-1/20 s-1
- Ordering number 130B1110 uncoated–130B1210 coated (Class G3/ISA S71.04-1985)

#### Analog I/O option MCB 109

This analog input/output option is easily fitted in the frequency converter for upgrading to advanced performance and control using the additional inputs/outputs. This option also upgrades the frequency converter with a battery backup supply for the clock built into the frequency converter. This provides stable use of all frequency converter clock functions as timed actions.

- 3 analog inputs, each configurable as both voltage and temperature input.
- Connection of 0–10 V analog signals as well as PT1000 and NI1000 temperature inputs.
- 3 analog outputs each configurable as 0–10 V outputs.
- Included back-up supply for the standard clock function in the frequency converter. The back-up battery typically lasts for 10 years, depending on environment. Ordering number 130B1143 uncoated – 130B1243 coated (Class G3/ISA S71.04-1985).

#### PTC thermistor card MCB 112

With the MCB 112 PTC thermistor card, all Danfoss frequency converters with STO can be used to supervise motors in potentially explosive atmospheres. MCB 112 offers superior performance compared to the built-in ETR function and thermistor terminal.

- Protects the motor from overheating.
- ATEX-approved for use with EX d and EX e motors.
- Uses the safe torque off function of Danfoss frequency converters to stop the motor in case of over temperature.
- Certified for use to protect motors in zones 1, 2, 21, and 22.
- Certified up to SIL2.

#### Sensor input card MCB 114

The option protects the motor from being overheated by monitoring the bearings and windings temperature in the motor. The limits, as well as the action, are adjustable and

the individual sensor temperature is visible as a read out in the display or by field bus.

- Protects the motor from overheating.
- 3 self-detecting sensor inputs for 2 or 3 wire PT100/PT1000 sensors.
- One additional analog input 4–20 mA.

#### Extended cascade controller MCO 101

Easily fitted and upgrades the built-in cascade controller to operate more pumps and more advanced pump control in master/slave mode.

- Up to 6 pumps in standard cascade set-up
- Up to 6 pumps in master/slave set-up
- Technical specification: See MCB 105 relay option

#### Extended relay card MCB 113

The extended relay card MCB 113 adds inputs/outputs to VLT® AQUA Drive for increased flexibility.

- 7 digital inputs: 0–24 V
- 2 analog outputs: 0/4–20 mA
- 4 SPDT relays
- Rating of load relays: 240 V AC/2 A (Ohm)
- Meets NAMUR recommendations
- Galvanic isolation capability Ordering number 130B1164 uncoated – 130B1264 coated (Class G3/ISA S71.04-1985)

#### MCO 102 advanced cascade controller

Extends the capabilities of the standard cascade controller built into frequency converters.

- Provides 8 additional relays for staging of additional motors.
- Provides accurate flow, pressure, and level control for optimising the efficiency of systems that use multiple pumps or blowers.
- Master/slave mode runs all blowers/pumps at the same speed, potentially reducing the energy consumption to less than half that of valve throttling or traditional, across-the-line on/off cycling.
- Lead-pump alternation assures that multiple pumps or blowers are used equally.

#### 24 V DC supply option MCB 107

The option is used to connect an external DC supply to keep the control section and any installed option active when mains power is down.

- Input voltage range: 24 V DC +/- 15% (max. 37 V in 10 s).
- Maximum input current: 2.2 A.
- Maximum cable length: 75 m.

- Input capacitance load: <10 uF.
  - Power-up delay: <0.6 s.
  - Easy to install in frequency converters in existing machines.
  - Keeps the control board and options active during power cuts.
  - Keeps fieldbuses active during power cuts
- Ordering number 130B1108 uncoated – 130B1208 coated (Class G3/ISA S71.04-1985).

### 3.7.1 Communication Options

- VLT® PROFIBUS DP V1 MCA 101
- VLT® DeviceNet MCA 104
- VLT® PROFINET MCA 120
- VLT® EtherNet/IP MCA 121
- VLT® Modbus TCP MCA 122

For further information, refer to *chapter 7 Specifications*.

### 3.7.2 Input/Output, Feedback and Safety Options

- VLT® General Purpose I/O Module MCB 101
- VLT® Relay Card MCB 105
- VLT® PTC Thermistor Card MCB 112
- VLT® Extended Relay Card MCB 113
- VLT® Sensor Input Option MCB 114

For further information, refer to *chapter 7 Specifications*.

### 3.7.3 Cascade Control Options

The cascade controller options extend the number of available relays. Once one of the options is installed, the parameters needed to support the cascade controller functions will be available through the control panel.

MCO 101 and 102 are add-on options extending the supported number of pumps and the functionalities of the built-in cascade controller in the VLT® AQUA Drive.

The following options for cascade control are available for the VLT® AQUA Drive:

- Built-in basic cascade controller (standard cascade controller)
- MCO 101 (extended cascade controller)
- MCO 102 (advanced cascade controller)

For further information, see *chapter 7 Specifications*.

The extended cascade controller can be used in 2 different modes:

- With the extended features controlled by parameter group 27-\*\*. *Cascade CTL Option*.
- To extend the number of available relays for the basic cascade controlled by parameter group 25-\*\*. *Cascade Controller*.

MCO 101 allows using a total of 5 relays for cascade control. MCO 102 allows controlling a total of 8 pumps. The options are able to alternate the lead pump with 2 relays per pump.

#### **NOTICE**

If MCO 102 is installed, the relay option MCB 105 can extend the number of relays to 13.

#### **Application**

Cascade control is a common control system used to control parallel pumps or fans in an energy-efficient way.

The cascade controller option enables control of multiple pumps configured in parallel by:

- Automatically turning individual pumps on/off.
- Controlling the speed of the pumps.

When using cascade controllers, the individual pumps are automatically turned on (staged) and turned off (de-staged) as needed in order to satisfy the required system output for flow or pressure. The speed of pumps connected to the VLT® AQUA Drive is also controlled to provide a continuous range of system output.

#### **Designated use**

The cascade controller options are designed for pump applications, however, it is also possible to use cascade controllers in any application requiring multiple motors configured in parallel.

#### **Operating principle**

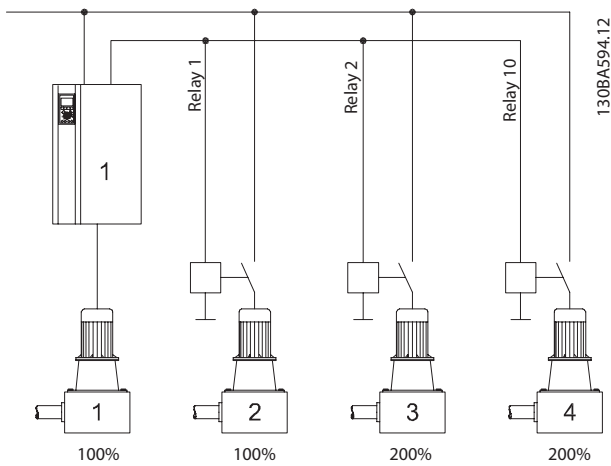
The cascade controller software runs from a single frequency converter with the cascade controller option. It controls a set of pumps, each controlled by a frequency converter or connected to a contactor or a soft starter.

Additional frequency converters in the system (slave frequency converters) do not need any cascade controller option card. They are operated in open-loop mode and receive their speed reference from the master frequency converter. Pumps connected to slave frequency converters are referred to as variable speed pumps.

Pumps connected to mains through a contactor or soft starter are referred to as fixed speed pumps.

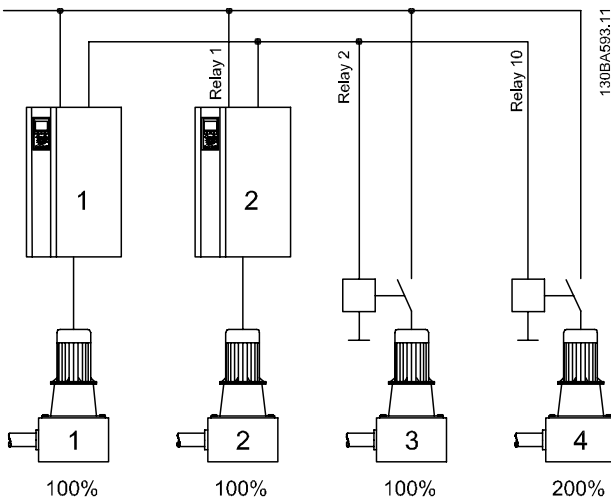
Each pump, variable speed or fixed speed, is controlled by a relay in the master frequency converter.

The cascade controller options can control a mix of variable speed and fixed speed pumps.



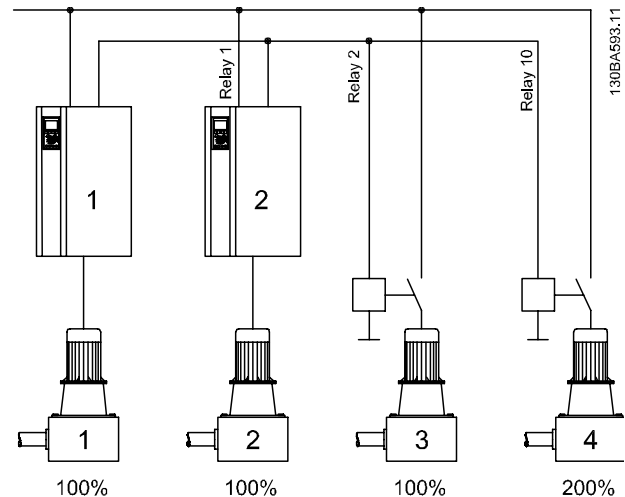
Built-in	1 VSP + 2 FSP parameter group 25-** Cascade Controller
MCO 101	1 VSP + 5 FSP parameter group 25-** Cascade Controller
MCO 102	1 VSP + 8 FSP parameter group 25-** Cascade Controller

Illustration 3.27 Application Overview



Built-in	-
MCO 101	1 to 6 VSP + 1 to 5 FSP (maximum 6 pumps) parameter group 27-** Cascade CTL Option
MCO 102	1 to 8 VSP + 1 to 7 FSP (maximum 8 pumps) parameter group 27-** Cascade CTL Option

Illustration 3.28 Application Overview



Built-in	-
MCO 101	6 VSP parameter group 27-** Cascade CTL Option
MCO 102	8 VSP parameter group 27-** Cascade CTL Option

Illustration 3.29 Application Overview

VSP = Variable speed pump (directly connected to the frequency converter)

FSP = Fixed speed pump (the motor could be connected via contactor, soft starter or star/delta starter)

### 3.7.4 Brake Resistors

In applications where the motor is used as a brake, energy is generated in the motor and sent back into the frequency converter. If the energy cannot be transported back to the motor, it increases the voltage in the frequency converter DC line. In applications with frequent braking and/or high inertia loads, this increase may lead to an overvoltage trip in the frequency converter and, finally, a shut down. Brake resistors are used to dissipate the excess energy resulting from the regenerative braking. The resistor is selected based on its ohmic value, its power dissipation rate and its physical size. Danfoss offers a wide variety of different resistors that are specially designed to Danfoss frequency converters. See *chapter 3.4.12 Brake Resistor Calculation* for dimensioning of brake resistors. For ordering numbers refer to *chapter 6.2 Options, Accessories, and Spare Parts*.

### 3.7.5 Sine-wave Filters

When a motor is controlled by a frequency converter, resonance noise is heard from the motor. This noise, which is the result of the motor design, arises every time an inverter switch in the frequency converter is activated. The frequency of the resonance noise thus corresponds to the switching frequency of the frequency converter.



Danfoss supplies a sine-wave filter to dampen the acoustic motor noise.

The filter reduces the ramp-up time of the voltage, the peak load voltage  $U_{PEAK}$  and the ripple current  $\Delta I$  to the motor, which means that current and voltage become almost sinusoidal. Consequently, the acoustic motor noise is reduced to a minimum.

The ripple current in the sine-wave filter coils also causes some noise. Solve the problem by integrating the filter in a cabinet or similar.

### 3.7.6 dU/dt Filters

Danfoss supplies dU/dt filters which are differential-mode, low-pass filters that reduce motor terminal phase-to-phase peak voltages and reduce the rise time to a level that lowers the stress on the insulation at the motor windings. This is especially an issue with short motor cables.

Compared to sine-wave filters (see *chapter 3.7.5 Sine-wave Filters*), the dU/dt filters have a cut off frequency above the switching frequency.

### 3.7.7 Common-mode Filters

High-frequency common-mode cores (HF-CM cores) reduce electromagnetic interference and eliminate bearing damage by electrical discharge. They are special nanocrystalline magnetic cores, which have superior filtering performance compared to regular ferrite cores. The HF-CM core acts like a common-mode inductor between phases and ground.

Installed around the 3 motor phases (U, V, W), the common mode filters reduce high-frequency common-mode currents. As a result, high-frequency electromagnetic interference from the motor cable is reduced.

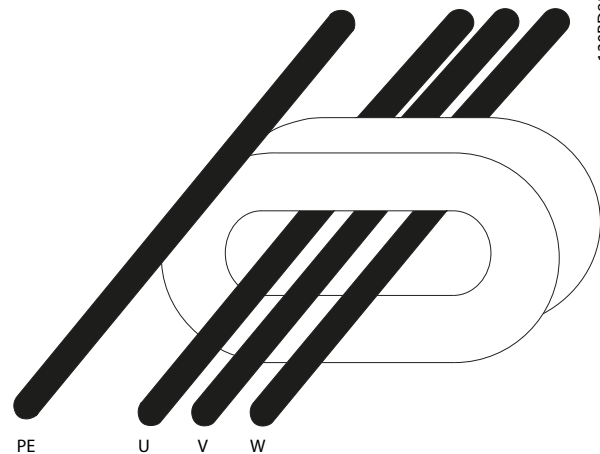
The number of cores required is dependent on motor cable length and frequency converter voltage. Each kit consists of 2 cores. Refer to *Table 3.19* to determine the number of cores required.

Cable length <sup>1)</sup> [m]	Enclosure size				
	A and B		C		D
	T2/T4	T7	T2/T4	T7	T7
50	2	4	2	2	4
100	4	4	2	4	4
150	4	6	4	4	4
300	4	6	4	4	6

**Table 3.19** Number of Cores

1) Where longer cables are required, stack additional HF-CM cores.

Install the HF-CM cores by passing the 3 motor phase cables (U, V, W) through each core, as shown in *Illustration 3.30*.



**Illustration 3.30** HF-CM Core with Motor Phases

### 3.7.8 Harmonic Filters

The Danfoss AHF 005 and AHF 010 are advanced harmonic filters, not to be compared with traditional harmonic trap filters. The Danfoss harmonic filters have been specially designed to match the Danfoss frequency converters.

By connecting the Danfoss harmonic filters AHF 005 or AHF 010 in front of a Danfoss frequency converter, the total harmonic current distortion generated back to the mains is reduced to 5% and 10%.

### 3.7.9 IP21/NEMA Type 1 Enclosure Kit

IP20/IP4X top/NEMA TYPE 1 is an optional enclosure element available for IP20 compact units. If the enclosure kit is used, an IP20 unit is upgraded to comply with enclosure IP21/4X top/TYPE 1.

The IP4X top can be applied to all standard IP20 FC 202 variants.

3

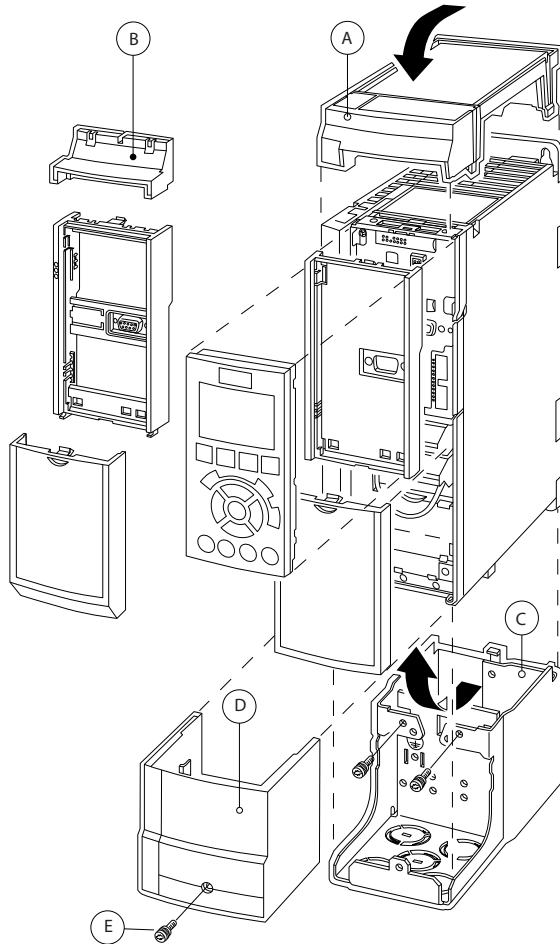
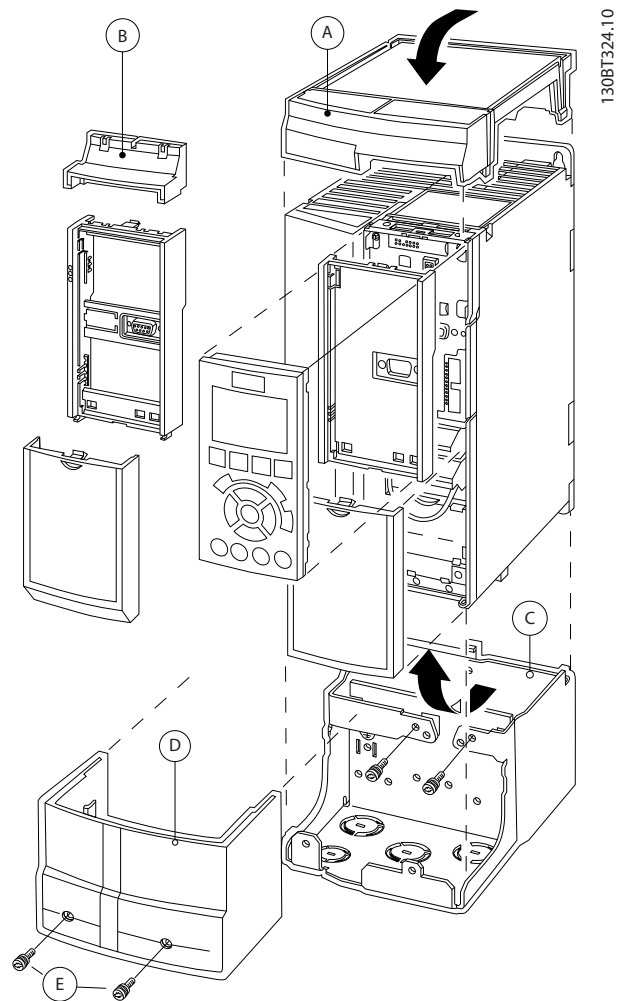


Illustration 3.31 Enclosure Size A2

130BT323:10



130BT324:10

A	Top cover
B	Brim
C	Base part
D	Base cover
E	Screw(s)

Illustration 3.32 Enclosure Size A3

Place the top cover as shown. If an A or B option is used, the brim must be fitted to cover the top inlet. Place the base part C at the bottom of the frequency converter and use the clamps from the accessory bag to fasten the cables correctly.

Holes for cable glands:

- Size A2: 2x M25 and 3xM32
- Size A3: 3xM25 and 3xM32

Enclosure type	Height A [mm]	Width B [mm]	Depth C <sup>1)</sup> [mm]
A2	372	90	205
A3	372	130	205
B3	475	165	249
B4	670	255	246
C3	755	329	337
C4	950	391	337

Table 3.20 Dimensions

1) If option A/B is used, the depth increases (see chapter 7.8 Power Ratings, Weight and Dimensions for details)

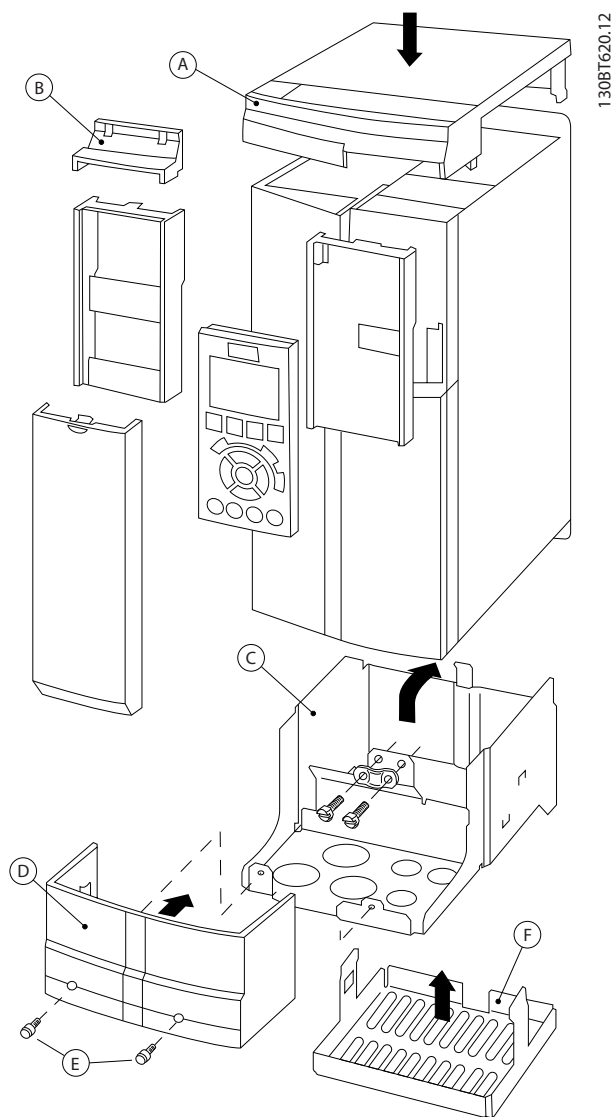


Illustration 3.33 Enclosure Size B3

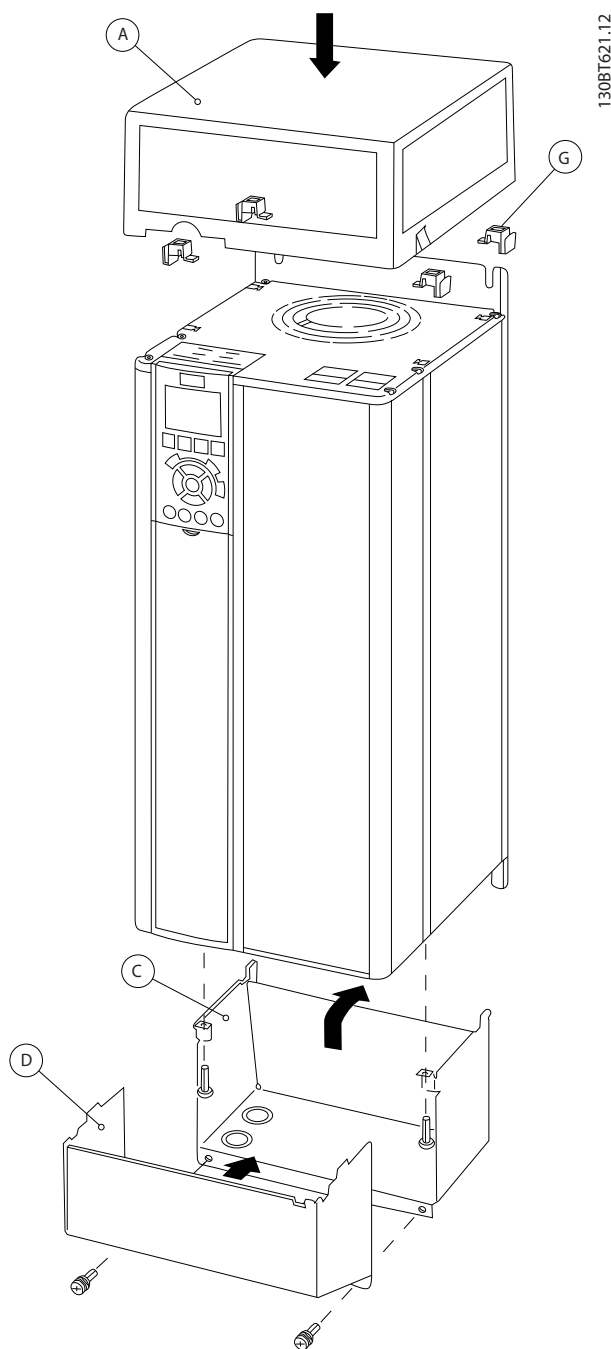


Illustration 3.34 Enclosure Sizes B4, C3, and C4

A	Top cover
B	Brim
C	Base part
D	Base cover
E	Screw(s)
F	Fan cover
G	Top clip

Table 3.21 Legend to Illustration 3.33 and Illustration 3.34

When option module A and/or option module B is/are used, fit the brim (B) to the top cover (A).

**NOTICE**

Side-by-side installation is not possible when using the IP21/IP4X/TYPE 1 Enclosure Kit

3

3.7.10 Remote Mounting Kit for LCP

The LCP can be moved to the front of an enclosure by using the remote built-in kit. The fastening screws must be tightened with a torque of maximum 1 Nm.

The LCP enclosure is rated IP66.

Enclosure	IP66 front
Maximum cable length between LCP and unit	3 m
Communication standard	RS485

Table 3.22 Technical Data

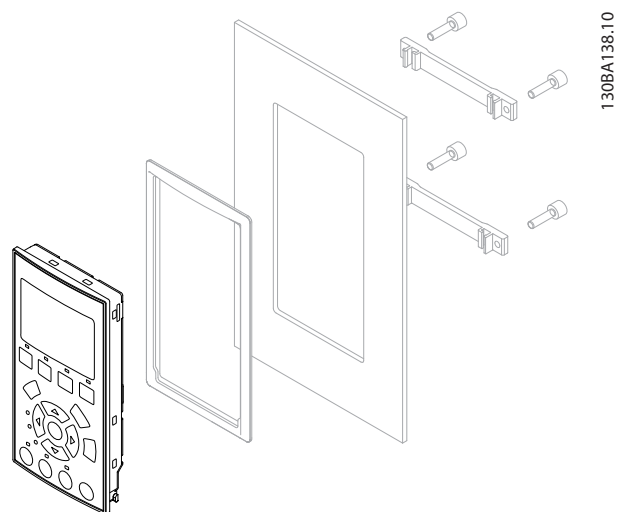


Illustration 3.35 LCP Kit with Graphical LCP, Fasteners, 3 m Cable and Gasket  
Ordering Number 130B1113

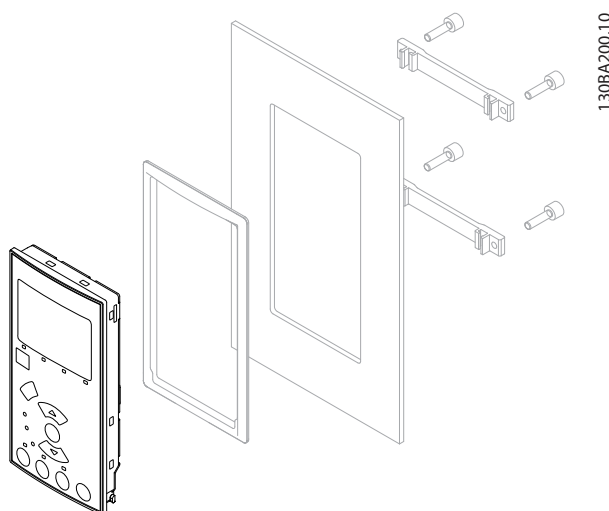


Illustration 3.36 LCP Kit with Numerical LCP, Fasteners and Gasket  
Ordering Number 130B1114

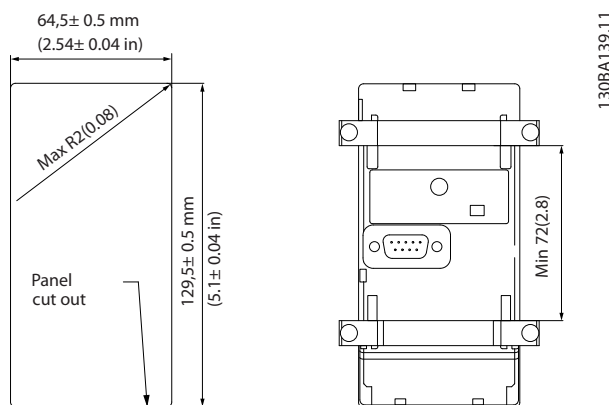


Illustration 3.37 Dimensions of LCP Kit

### 3.7.11 Mounting Bracket for Enclosure Sizes A5, B1, B2, C1 and C2

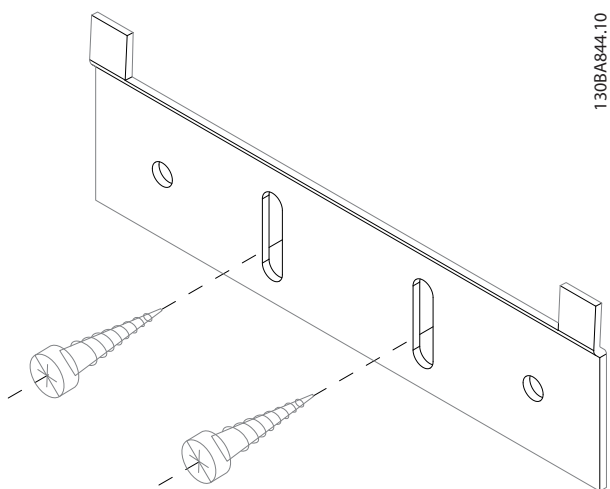


Illustration 3.38 Lower Bracket

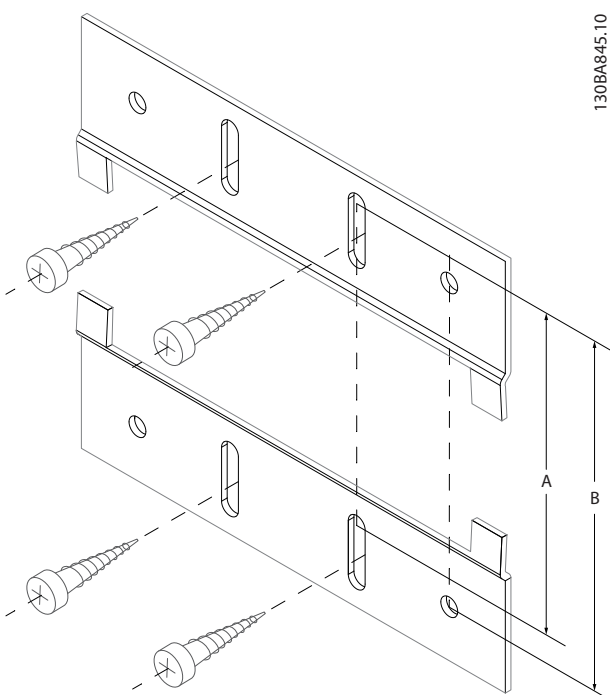


Illustration 3.39 Upper Bracket

See dimensions in *Table 3.23*.

Enclosure Size	IP	A [mm]	B [mm]	Ordering number
A5	55/66	480	495	130B1080
B1	21/55/66	535	550	130B1081
B2	21/55/66	705	720	130B1082
B3	21/55/66	730	745	130B1083
B4	21/55/66	820	835	130B1084

Table 3.23 Details of Mounting Brackets

### 3.8 Serial Interface RS485

#### 3.8.1 Overview

RS485 is a 2-wire bus interface compatible with multi-drop network topology, that is, nodes can be connected as a bus, or via drop cables from a common trunk line. A total of 32 nodes can be connected to 1 network segment. Repeaters divide network segments, see *Illustration 3.40*.

**NOTICE**

Each repeater functions as a node within the segment in which it is installed. Each node connected within a given network must have a unique node address across all segments.

Terminate each segment at both ends, using either the termination switch (S801) of the frequency converters or a biased termination resistor network. Always use screened twisted pair (STP) cable for bus cabling, and follow good common installation practice.

Low-impedance ground connection of the screen at every node is important, including at high frequencies. Thus, connect a large surface of the screen to ground, for example, with a cable clamp or a conductive cable gland. It may be necessary to apply potential-equalising cables to maintain the same earth potential throughout the network, particularly in installations with long cables. To prevent impedance mismatch, always use the same type of cable throughout the entire network. When connecting a motor to the frequency converter, always use screened motor cable.

Cable	Screened twisted pair (STP)
Impedance [ $\Omega$ ]	120
Cable length [m]	Maximum 1200 (including drop lines) Maximum 500 station-to-station

Table 3.24 Cable Specifications

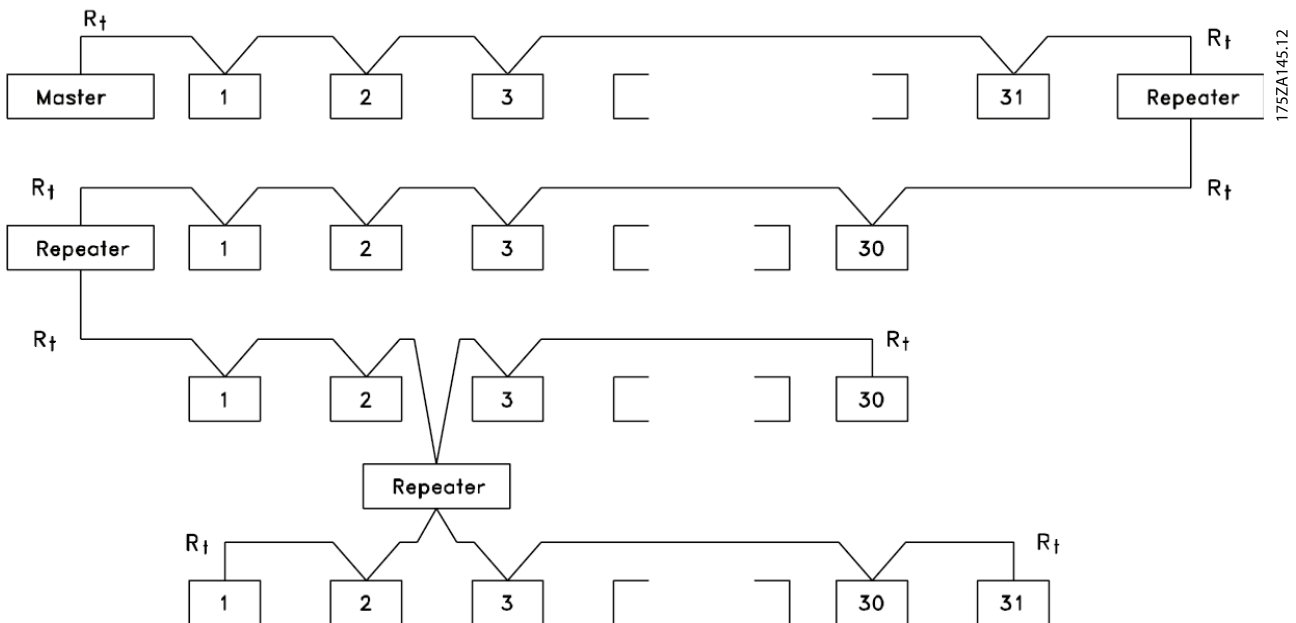


Illustration 3.40 RS485 Bus Interface

		Parameters	
FC		Function	Setting
+24 V	12	8-30 Protocol	FC*
+24 V	13	8-31 Address	1*
D IN	18	8-32 Baud Rate	9600*
D IN	19	* = Default value	
COM	20	<b>Notes/comments:</b>	
D IN	27	Select protocol, address and baud rate in the above mentioned parameters.	
D IN	29	D IN 37 is an option.	
D IN	32		
D IN	33		
D IN	37		
+10 V	50		
A IN	53		
A IN	54		
COM	55		
A OUT	42		
COM	39		
R1	01, 02, 03		
R2	04, 05, 06		
	61, 68, 69	RS-485	

Table 3.25 RS485 Network Connection

### 3.8.2 Network Connection

One or more frequency converters can be connected to a control (or master) using the RS485 standardised interface. Terminal 68 is connected to the P signal (TX+, RX+), while terminal 69 is connected to the N signal (TX-,RX-). See drawings in *chapter 3.5.1 Wiring Schematic*.

If more than one frequency converter is connected to a master, use parallel connections.

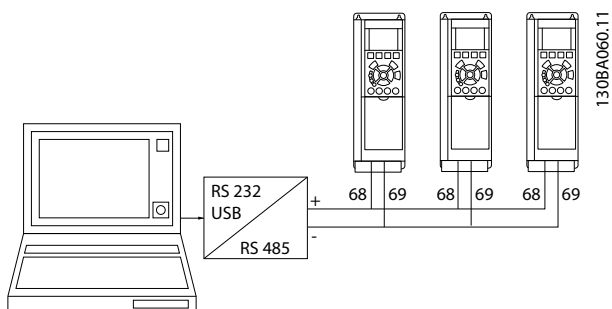


Illustration 3.41 Parallel Connections

To avoid potential equalising currents in the screen, wire according to *Illustration 3.20*.

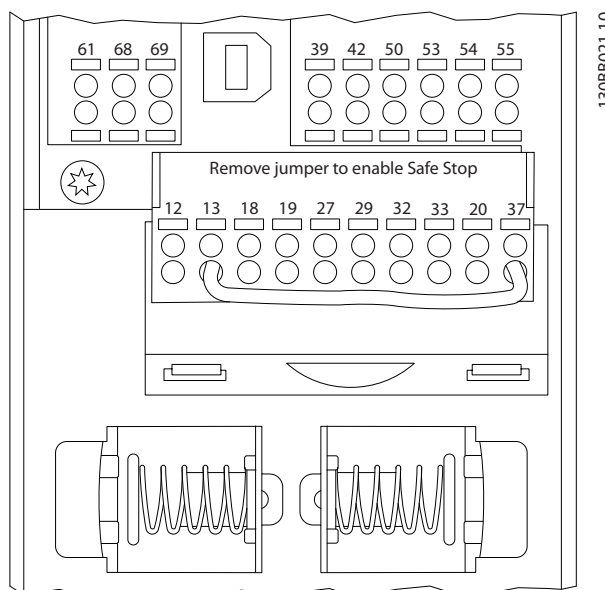


Illustration 3.42 Control Card Terminals

### 3.8.3 RS485 Bus Termination

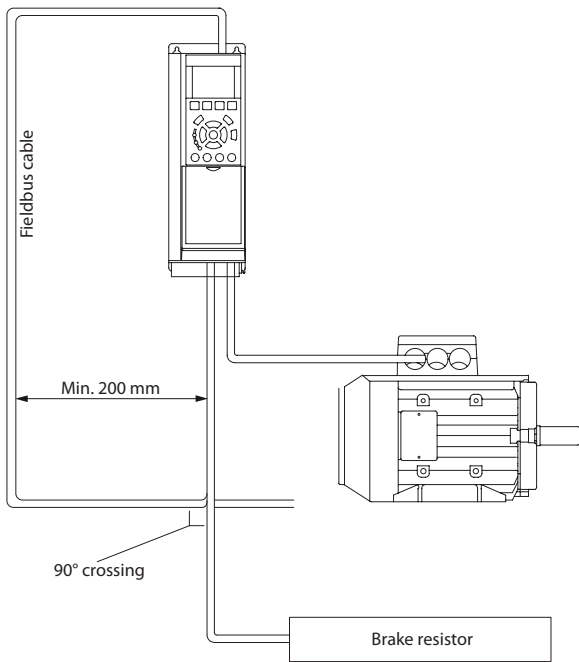
Terminate RS485 bus with a resistor network at both ends. For this purpose, set switch S801 on the control card to ON.

Set the communication protocol to *8-30 Protocol*.

### 3.8.4 EMC Precautions

The following EMC precautions are recommended to achieve interference-free operation of the RS485 network.

Observe relevant national and local regulations, for example, regarding protective earth connection. Keep the RS485 communication cable away from motor and brake resistor cables to avoid coupling of high frequency noise from one cable to another. Normally, a distance of 200 mm (8 inches) is sufficient, but keeping the greatest possible distance between the cables is recommended, especially where cables run in parallel over long distances. When crossing is unavoidable, the RS485 cable must cross motor and brake resistor cables at an angle of 90°.



1308D507.11

Illustration 3.43 Cable Routing

### 3.8.5 FC Protocol Overview

The FC protocol, also referred to as FC bus or standard bus, is the Danfoss standard fieldbus. It defines an access technique according to the master-slave principle for communications via a serial bus.

1 master and a maximum of 126 slaves can be connected to the bus. The master selects the individual slaves via an address character in the telegram. A slave itself can never transmit without first being requested to do so, and direct message transfer between the individual slaves is not possible. Communications occur in the half-duplex mode. The master function cannot be transferred to another node (single-master system).

The physical layer is RS485, thus utilising the RS485 port built into the frequency converter. The FC protocol supports different telegram formats:

- A short format of 8 bytes for process data.
- A long format of 16 bytes that also includes a parameter channel.
- A format used for texts.

### 3.8.6 Network Configuration

Set the following parameters to enable the FC protocol for the frequency converter:

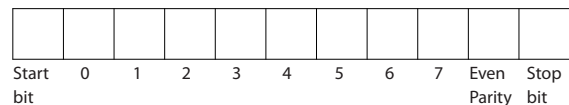
Parameter number	Setting
8-30 Protocol	FC
8-31 Address	1–126
8-32 Baud Rate	2400–115200
8-33 Parity / Stop Bits	Even parity, 1 stop bit (default)

Table 3.26 FC Protocol Parameters

### 3.8.7 FC Protocol Message Framing Structure

#### 3.8.7.1 Content of a Character (byte)

Each character transferred begins with a start bit. Then 8 data bits are transferred, corresponding to a byte. Each character is secured via a parity bit. This bit is set at 1 when it reaches parity. Parity is when there is an equal number of 1s in the 8 data bits and the parity bit in total. A stop bit completes a character, thus consisting of 11 bits in all.



195NA036.10

Illustration 3.44 Content of a Character

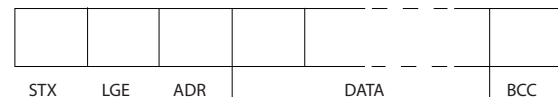
#### 3.8.7.2 Telegram Structure

Each telegram has the following structure:

- Start character (STX)=02 hex.
- A byte denoting the telegram length (LGE).
- A byte denoting the frequency converter address (ADR).

A number of data bytes (variable, depending on the type of telegram) follows.

A data control byte (BCC) completes the telegram.



195NA099.10

Illustration 3.45 Telegram Structure



### 3.8.7.3 Telegram Length (LGE)

The telegram length is the number of data bytes plus the address byte ADR and the data control byte BCC.

4 data bytes	LGE=4+1+1=6 bytes
12 data bytes	LGE=12+1+1=14 bytes
Telegrams containing texts	10 <sup>1</sup> +n bytes

**Table 3.27 Length of Telegrams**

1) 10 represents the fixed characters, while n is variable (depending on the length of the text).

### 3.8.7.4 Frequency Converter Address (ADR)

2 different address formats are used.

The address range of the frequency converter is either 1-31 or 1-126.

- Address format 1-31
  - Bit 7=0 (address format 1-31 active).
  - Bit 6 is not used.
  - Bit 5=1: Broadcast, address bits (0-4) are not used.
  - Bit 5=0: No Broadcast.
  - Bit 0-4=frequency converter address 1-31.
- Address format 1-126
  - Bit 7=1 (address format 1-126 active).
  - Bit 0-6=frequency converter address 1-126.
  - Bit 0-6 =0 Broadcast.

The slave returns the address byte unchanged to the master in the response telegram.

### 3.8.7.5 Data Control Byte (BCC)

The checksum is calculated as an XOR-function. Before the first byte in the telegram is received, the calculated checksum is 0.

3

### 3.8.7.6 The Data Field

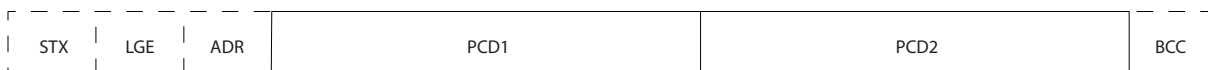
The structure of data blocks depends on the type of telegram. There are 3 telegram types, and the type applies for both control telegrams (master→slave) and response telegrams (slave→master).

The 3 types of telegram are:

#### Process block (PCD)

The PCD is made up of a data block of 4 bytes (2 words) and contains:

- Control word and reference value (from master to slave).
- Status word and present output frequency (from slave to master).

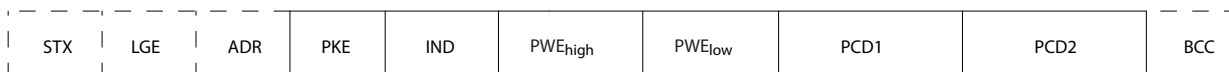


130BA269.10

Illustration 3.46 Process Block

#### Parameter block

The parameter block is used to transfer parameters between master and slave. The data block is made up of 12 bytes (6 words) and also contains the process block.

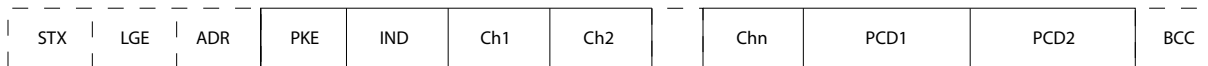


130BA271.10

Illustration 3.47 Parameter Block

#### Text block

The text block is used to read or write texts via the data block.



130BA270.10

Illustration 3.48 Text Block

### 3.8.7.7 The PKE Field

The PKE field contains 2 sub-fields:

- Parameter command and response AK.
- Parameter number PNU.

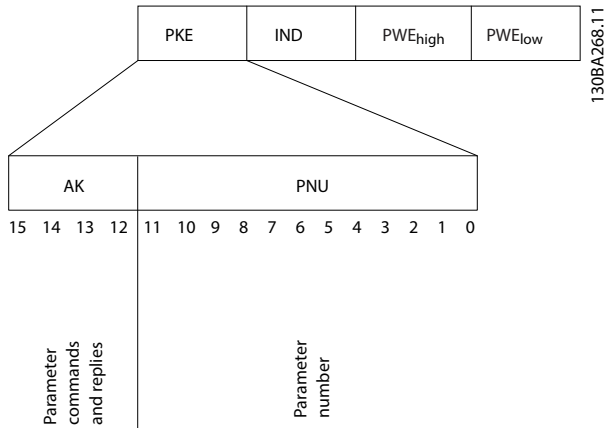


Illustration 3.49 PKE Field

Bits number 12-15 transfer parameter commands from master to slave and return processed slave responses to the master.

Bit number				Parameter command
15	14	13	12	
0	0	0	0	No command
0	0	0	1	Read parameter value
0	0	1	0	Write parameter value in RAM (word)
0	0	1	1	Write parameter value in RAM (double word)
1	1	0	1	Write parameter value in RAM and EEPROM (double word)
1	1	1	0	Write parameter value in RAM and EEPROM (word)
1	1	1	1	Read/write text

Table 3.28 Parameter Commands Master⇒Slave

Bit number				Response
15	14	13	12	
0	0	0	0	No response
0	0	0	1	Parameter value transferred (word)
0	0	1	0	Parameter value transferred (double word)
0	1	1	1	Command cannot be performed
1	1	1	1	text transferred

Table 3.29 Response Slave⇒Master

If the command cannot be performed, the slave sends this response:

0111 Command cannot be performed

- and issues a fault report (see Table 3.30) in the parameter value (PWE):

PWE low (hex)	Fault report
0	The parameter number used does not exist.
1	There is no write access to the defined parameter.
2	Data value exceeds the parameter's limits.
3	The sub index used does not exist.
4	The parameter is not the array type.
5	The data type does not match the defined parameter.
11	Data change in the defined parameter is not possible in the frequency converter's present mode. Certain parameters can only be changed when the motor is turned off.
82	There is no bus access to the defined parameter.
83	Data change is not possible because factory set-up is selected

Table 3.30 Parameter Value Fault Report

### 3.8.7.8 Parameter Number (PNU)

Bits number 0-11 transfer parameter numbers. The function of the relevant parameter is defined in the parameter description in the *Programming Guide*.

### 3.8.7.9 Index (IND)

The index is used together with the parameter number to read/write-access parameters with an index, e.g. 15-30 Alarm Log: Error Code. The index consists of 2 bytes, a low byte and a high byte.

Only the low byte is used as an index.

### 3.8.7.10 Parameter Value (PWE)

The parameter value block consists of 2 words (4 bytes), and the value depends on the defined command (AK). The master prompts for a parameter value when the PWE block contains no value. To change a parameter value (write), write the new value in the PWE block and send from the master to the slave.

When a slave responds to a parameter request (read command), the present parameter value in the PWE block is transferred and returned to the master. If a parameter does not contain a numerical value, but several data options, e.g. 0-01 Language where [0] is English, and [4] is Danish, select the data value by entering the value in the PWE block. Serial communication is only capable of reading parameters containing data type 9 (text string).

15-40 FC Type to 15-53 Power Card Serial Number contain data type 9.

For example, read the unit size and mains voltage range in 15-40 FC Type. When a text string is transferred (read), the length of the telegram is variable, and the texts are of different lengths. The telegram length is defined in the

second byte of the telegram, LGE. When using text transfer, the index character indicates whether it is a read or a write command.

To read a text via the PWE block, set the parameter command (AK) to F hex. The index character high-byte must be 4.

Some parameters contain text that can be written to via the serial bus. To write a text via the PWE block, set the parameter command (AK) to F hex. The index characters high-byte must be 5.

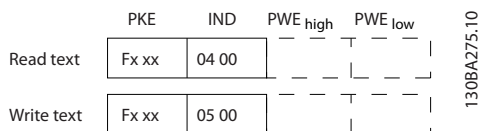


Illustration 3.50 Text via PWE Block

### 3.8.7.11 Supported Data Types

Unsigned means that there is no operational sign in the telegram.

Data types	Description
3	Integer 16
4	Integer 32
5	Unsigned 8
6	Unsigned 16
7	Unsigned 32
9	Text string
10	Byte string
13	Time difference
33	Reserved
35	Bit sequence

Table 3.31 Supported Data Types

### 3.8.7.12 Conversion

The various attributes of each parameter are displayed in factory setting. Parameter values are transferred as whole numbers only. Conversion factors are therefore used to transfer decimals.

4-12 Motor Speed Low Limit [Hz] has a conversion factor of 0.1. To preset the minimum frequency to 10 Hz, transfer the value 100. A conversion factor of 0.1 means that the value transferred is multiplied by 0.1. The value 100 is therefore read as 10.0.

Examples:

- 0 s⇒conversion index 0
- 0.00 s⇒conversion index -2
- 0 ms⇒conversion index -3
- 0.00 ms⇒conversion index -5

### 3.8.7.13 Process Words (PCD)

The block of process words is divided into 2 blocks of 16 bits, which always occur in the defined sequence.

PCD 1	PCD 2
Control telegram (master⇒slave control word)	Reference-value
Control telegram (slave⇒master) status word	Present output frequency

Table 3.32 Process Words (PCD)

## 3.8.8 FC Protocol Examples

### 3.8.8.1 Writing a Parameter Value

Change 4-14 Motor Speed High Limit [Hz] to 100 Hz. Write the data in EEPROM.

PKE=E19E hex - Write single word in 4-14 Motor Speed High Limit [Hz].  
 IND=0000 hex  
 PWEHIGH=0000 hex  
 PWELOW=03E8 hex - Data value 1000, corresponding to 100 Hz, see chapter 3.8.7.12 Conversion.

The telegram looks like this:

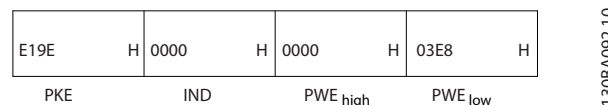


Illustration 3.51 Write Data in EEPROM

## NOTICE

4-14 Motor Speed High Limit [Hz] is a single word, and the parameter command for write in EEPROM is E. Parameter number 4-14 is 19E in hexadecimal.

The response from the slave to the master is:

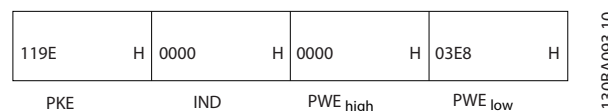


Illustration 3.52 Response from Slave

### 3.8.8.2 Reading a Parameter Value

Read the value in 3-41 Ramp 1 Ramp Up Time.

PKE=1155 hex - Read parameter value in 3-41 Ramp 1 Ramp Up Time.  
 IND=0000 hex  
 PWEHIGH=0000 hex  
 PWELOW=0000 hex

1155	H	0000	H	0000	H	0000	H
PKE		IND		PWE <sub>high</sub>		PWE <sub>low</sub>	

130BA094.10

Illustration 3.53 Parameter Value

If the value in 3-41 Ramp 1 Ramp Up Time is 10 s, the response from the slave to the master is

1155	H	0000	H	0000	H	03E8	H
PKE		IND		PWE <sub>high</sub>		PWE <sub>low</sub>	

130BA267.10

Illustration 3.54 Response from Slave

3E8 hex corresponds to 1000 decimal. The conversion index for 3-41 Ramp 1 Ramp Up Time is -2, i.e. 0.01. 3-41 Ramp 1 Ramp Up Time is of the type *Unsigned 32*.

### 3.8.9 Modbus RTU Protocol

#### 3.8.9.1 Assumptions

Danfoss assumes that the installed controller supports the interfaces in this document, and strictly observes all requirements and limitations stipulated in the controller and frequency converter.

The built-in Modbus RTU (Remote Terminal Unit) is designed to communicate with any controller that supports the interfaces defined in this document. It is assumed that the user has full knowledge of the capabilities and limitations of the controller.

#### 3.8.9.2 Modbus RTU Overview

Regardless of the type of physical communication networks, the Modbus RTU overview describes the process a controller uses to request access to another device. This process includes how the Modbus RTU responds to requests from another device, and how errors are detected and reported. It also establishes a common format for the layout and contents of message fields.

During communications over a Modbus RTU network, the protocol:

- Determines how each controller learns its device address.
- Recognises a message addressed to it.
- Determines which actions to take.
- Extracts any data or other information contained in the message.

If a reply is required, the controller constructs the reply message and sends it.

Controllers communicate using a master-slave technique in which only the master can initiate transactions (called

queries). Slaves respond by supplying the requested data to the master, or by taking the action requested in the query.

The master can address individual slaves, or initiate a broadcast message to all slaves. Slaves return a response to queries that are addressed to them individually. No responses are returned to broadcast queries from the master. The Modbus RTU protocol establishes the format for the master's query by providing:

- The device (or broadcast) address.
- A function code defining the requested action.
- Any data to be sent.
- An error-checking field.

The slave's response message is also constructed using Modbus protocol. It contains fields confirming the action taken, any data to be returned, and an error-checking field. If an error occurs in receipt of the message, or if the slave is unable to perform the requested action, the slave constructs an error message, and send it in response, or a time-out occurs.

#### 3.8.9.3 Frequency Converter with Modbus RTU

The frequency converter communicates in Modbus RTU format over the built-in RS485 interface. Modbus RTU provides access to the control word and bus reference of the frequency converter.

The control word allows the modbus master to control several important functions of the frequency converter:

- Start
- Stop of the frequency converter in various ways:
  - Coast stop
  - Quick stop
  - DC brake stop
  - Normal (ramp) stop
- Reset after a fault trip
- Run at a variety of preset speeds
- Run in reverse
- Change the active set-up
- Control the frequency converter's built-in relay

The bus reference is commonly used for speed control. It is also possible to access the parameters, read their values, and, where possible, write values to them. This permits a range of control options, including controlling the setpoint of the frequency converter when its internal PI controller is used.

### 3.8.9.4 Network Configuration

To enable Modbus RTU on the frequency converter, set the following parameters:

Parameter	Setting
8-30 Protocol	Modbus RTU
8-31 Address	1-247
8-32 Baud Rate	2400-115200
8-33 Parity / Stop Bits	Even parity, 1 stop bit (default)

Table 3.33 Modbus RTU Parameters

### 3.8.10 Modbus RTU Message Framing Structure

#### 3.8.10.1 Frequency Converter with Modbus RTU

The controllers are set up to communicate on the Modbus network using RTU mode, with each byte in a message containing 2 4-bit hexadecimal characters. The format for each byte is shown in Table 3.34.

Start bit	Data byte	Stop/parity	Stop

Table 3.34 Format for Each Byte

Coding system	8-bit binary, hexadecimal 0–9, A–F. 2 hexadecimal characters contained in each 8-bit field of the message.
Bits per byte	1 start bit. 8 data bits, least significant bit sent first; 1 bit for even/odd parity; no bit for no parity. 1 stop bit if parity is used; 2 bits if no parity.
Error check field	Cyclical redundancy check (CRC).

#### 3.8.10.2 Modbus RTU Message Structure

The transmitting device places a Modbus RTU message into a frame with a known beginning and ending point. This allows receiving devices to begin at the start of the message, read the address portion, determine which device is addressed (or all devices, if the message is broadcast), and to recognise when the message is completed. Partial messages are detected and errors set as a result. Characters for transmission must be in hexadecimal 00 to FF format in each field. The frequency converter continuously monitors the network bus, also during silent intervals. When the first field (the address field) is received, each frequency converter or device decodes it to determine which device is being addressed. Modbus RTU messages addressed to zero are broadcast messages. No response is permitted for broadcast messages. A typical message frame is shown in Table 3.35.

Start	Address	Function	Data	CRC check	End
T1-T2-T3-T4	8 bits	8 bits	N x 8 bits	16 bits	T1-T2-T3-T4

Table 3.35 Typical Modbus RTU Message Structure

#### 3.8.10.3 Start/Stop Field

Messages start with a silent period of at least 3.5 character intervals. This is implemented as a multiple of character intervals at the selected network baud rate (shown as Start T1-T2-T3-T4). The first field to be transmitted is the device address. Following the last transmitted character, a similar period of at least 3.5 character intervals marks the end of the message. A new message can begin after this period. The entire message frame must be transmitted as a continuous stream. If a silent period of more than 1.5 character intervals occurs before completion of the frame, the receiving device flushes the incomplete message and assumes that the next byte is the address field of a new message. Similarly, if a new message begins before 3.5 character intervals after a previous message, the receiving device considers it a continuation of the previous message. This causes a time-out (no response from the slave), since the value in the final CRC field is not valid for the combined messages.

#### 3.8.10.4 Address Field

The address field of a message frame contains 8 bits. Valid slave device addresses are in the range of 0–247 decimal. The individual slave devices are assigned addresses in the range of 1–247. (0 is reserved for broadcast mode, which all slaves recognise.) A master addresses a slave by placing the slave address in the address field of the message. When the slave sends its response, it places its own address in this address field to let the master know which slave is responding.

#### 3.8.10.5 Function Field

The function field of a message frame contains 8 bits. Valid codes are in the range of 1–FF. Function fields are used to send messages between master and slave. When a message is sent from a master to a slave device, the function code field tells the slave what kind of action to perform. When the slave responds to the master, it uses the function code field to indicate either a normal (error-free) response, or that some kind of error occurred (called an exception response). For a normal response, the slave simply echoes the original function code. For an exception response, the slave returns a code that is equivalent to the original function code with its most significant bit set to logic 1. In addition, the slave places a unique code into the data field of the response message. This tells the master what kind of error occurred, or the reason for the

exception. Also refer to *chapter 3.8.10.10 Function Codes Supported by Modbus RTU* and *chapter 3.8.10.11 Modbus Exception Codes*.

### 3.8.10.6 Data Field

The data field is constructed using sets of 2 hexadecimal digits, in the range of 00–FF hexadecimal. These are made up of 1 RTU character. The data field of messages sent from a master to slave device contains additional information, which the slave must use to take the action defined by the function code. This can include items such as coil or register addresses, the quantity of items to be handled, and the count of actual data bytes in the field.

### 3.8.10.7 CRC Check Field

Messages include an error-checking field, operating based on a cyclical redundancy check (CRC) method. The CRC field checks the contents of the entire message. It is applied regardless of any parity check method used for the individual characters of the message. The CRC value is calculated by the transmitting device, which appends the CRC as the last field in the message. The receiving device recalculates a CRC during receipt of the message and compares the calculated value to the actual value received in the CRC field. If the 2 values are unequal, a bus time-out results. The error-checking field contains a 16-bit binary value implemented as 2 8-bit bytes. When this is done, the low-order byte of the field is appended first, followed by the high-order byte. The CRC high-order byte is the last byte sent in the message.

### 3.8.10.8 Coil Register Addressing

In Modbus, all data is organised in coils and holding registers. Coils hold a single bit, whereas holding registers hold a 2-byte word (16 bits). All data addresses in Modbus messages are referenced to zero. The first occurrence of a data item is addressed as item number 0. For example: The coil known as *coil 1* in a programmable controller is addressed as the data address field of a Modbus message. *Coil 127 decimal* is addressed as *coil 007EHEX (126 decimal)*. *Holding register 40001* is addressed as *register 0000* in the data address field of the message. The function code field already specifies a holding-register operation. Therefore, the 4XXXX reference is implicit. *Holding register 40108* is addressed as *register 006BHEX (107 decimal)*.

Coil number	Description	Signal direction
1–16	Frequency converter control word.	Master to slave
17–32	Frequency converter speed or setpoint reference range 0x0–0xFFFF (-200% ... ~200%).	Master to slave
33–48	Frequency converter status word (see <i>Table 3.38</i> )	Slave to master
49–64	Open-loop mode: Frequency converter output frequency. Closed-loop mode: Frequency converter feedback signal.	Slave to master
65	Parameter write control (master to slave)	Master to slave
	0 = Parameter changes are written to the RAM of the frequency converter.	
	1 = Parameter changes are written to the RAM and EEPROM of the frequency converter.	
66–65536	Reserved	

Table 3.36 Coil Descriptions

Coil	0	1
01	Preset reference LSB	
02	Preset reference MSB	
03	DC brake	No DC brake
04	Coast stop	No coast stop
05	Quick stop	No quick stop
06	Freeze freq.	No freeze freq.
07	Ramp stop	Start
08	No reset	Reset
09	No jog	Jog
10	Ramp 1	Ramp 2
11	Data not valid	Data valid
12	Relay 1 off	Relay 1 on
13	Relay 2 off	Relay 2 on
14	Set up LSB	
15	Set up MSB	
16	No reversing	Reversing

Table 3.37 Frequency Converter Control Word (FC Profile)

Coil	0	1
33	Control not ready	Control ready
34	Frequency converter not ready	Frequency converter ready
35	Coasting stop	Safety closed
36	No alarm	Alarm
37	Not used	Not used
38	Not used	Not used
39	Not used	Not used
40	No warning	Warning
41	Not at reference	At reference
42	Hand mode	Auto mode
43	Out of frequency range	In frequency range
44	Stopped	Running
45	Not used	Not used
46	No voltage warning	Voltage warning
47	Not in current limit	Current limit
48	No thermal warning	Thermal warning

**Table 3.38 Frequency Converter Status Word (FC Profile)**

Register number	Description
00001-00006	Reserved
00007	Last error code from an FC data object interface
00008	Reserved
00009	Parameter index <sup>1)</sup>
00010-00990	000 parameter group (parameters 0-01 through 0-99)
01000-01990	100 parameter group (parameters 1-00 through 1-99)
02000-02990	200 parameter group (parameters 2-00 through 2-99)
03000-03990	300 parameter group (parameters 3-00 through 3-99)
04000-04990	400 parameter group (parameters 4-00 through 4-99)
...	...
49000-49990	4900 parameter group (parameters 49-00 through 49-99)
50000	Input data: Frequency converter control word register (CTW).
50010	Input data: Bus reference register (REF).
...	...
50200	Output data: Frequency converter status word register (STW).
50210	Output data: Frequency converter main actual value register (MAV).

**Table 3.39 Holding Registers**

1) Used to specify the index number to be used when accessing an indexed parameter.

### 3.8.10.9 How to Control the Frequency Converter

Codes available for use in the function and data fields of a Modbus RTU message are listed in *chapter 3.8.10.10 Function Codes Supported by Modbus RTU* and *chapter 3.8.10.11 Modbus Exception Codes*.

### 3.8.10.10 Function Codes Supported by Modbus RTU

Modbus RTU supports use of the function codes (see *Table 3.40*) in the function field of a message.

Function	Function code (hex)
Read coils	1
Read holding registers	3
Write single coil	5
Write single register	6
Write multiple coils	F
Write multiple registers	10
Get communication event counter	B
Report slave ID	11

**Table 3.40 Function Codes**

Function	Function code	Sub-function code	Sub-function
Diagnostics	8	1	Restart communication
		2	Return diagnostic register
		10	Clear counters and diagnostic register
		11	Return bus message count
		12	Return bus communication error count
		13	Return slave error count
		14	Return slave message count

**Table 3.41 Function Codes and Sub-function Codes**



### 3.8.10.11 Modbus Exception Codes

For a full explanation of the structure of an exception code response, refer to *chapter 3.8.10.5 Function Field*.

Code	Name	Meaning
1	Illegal function	The function code received in the query is not an allowable action for the server (or slave). This may be because the function code is only applicable to newer devices, and was not implemented in the unit selected. It could also indicate that the server (or slave) is in the wrong state to process a request of this type, for example because it is not configured and is being asked to return register values.
2	Illegal data address	The data address received in the query is not an allowable address for the server (or slave). More specifically, the combination of reference number and transfer length is invalid. For a controller with 100 registers, a request with offset 96 and length 4 would succeed, a request with offset 96 and length 5 generates exception 02.
3	Illegal data value	A value contained in the query data field is not an allowable value for server (or slave). This indicates a fault in the structure of the remainder of a complex request, such as that the implied length is incorrect. It specifically does NOT mean that a data item submitted for storage in a register has a value outside the expectation of the application program, since the Modbus protocol is unaware of the significance of any particular value of any particular register.
4	Slave device failure	An unrecoverable error occurred while the server (or slave) was attempting to perform the requested action.

Table 3.42 Modbus Exception Codes

## 3.8.11 Access to Parameters

### 3.8.11.1 Parameter Handling

The PNU (parameter number) is translated from the register address contained in the Modbus read or write message. The parameter number is translated to Modbus as (10 x parameter number) decimal. Example: Reading 3-12 *Catch up/slow Down Value* (16 bit): The holding register 3120 holds the parameters value. A value of 1352 (Decimal), means that the parameter is set to 12.52%

Reading 3-14 *Preset Relative Reference* (32bit): The holding registers 3410 & 3411 holds the parameter's value. A value of 11300 (decimal), means that the parameter is set to 1113.00.

For information on the parameters, size and converting index, consult the *programming guide*.

### 3.8.11.2 Storage of Data

The coil 65 decimal determines whether data written to the frequency converter is stored in EEPROM and RAM (coil 65=1) or only in RAM (coil 65=0).

### 3.8.11.3 IND (Index)

Some parameters in the frequency converter are array parameters, for example, 3-10 *Preset Reference*. Since the Modbus does not support arrays in the holding registers, the frequency converter has reserved the holding register 9 as pointer to the array. Before reading or writing an array parameter, set the holding register 9. Setting the holding register to the value of 2 causes all following read/write to array parameters to be to the index 2.

### 3.8.11.4 Text Blocks

Parameters stored as text strings are accessed in the same way as the other parameters. The maximum text block size is 20 characters. If a read request for a parameter is for more characters than the parameter stores, the response is truncated. If the read request for a parameter is for fewer characters than the parameter stores, the response is space filled.

### 3.8.11.5 Conversion Factor

Since a parameter value can only be transferred as a whole number, a conversion factor must be used to transfer decimals.

### 3.8.11.6 Parameter Values

#### Standard data types

Standard data types are int 16, int 32, uint 8, uint 16 and uint 32. They are stored as 4x registers (40001–4FFFF). The parameters are read using function 03 hex *Read Holding Registers*. Parameters are written using the function 6 hex *Preset Single Register* for 1 register (16 bits), and the function 10 hex *Preset Multiple Registers* for 2 registers (32 bits). Readable sizes range from 1 register (16 bits) up to 10 registers (20 characters).

#### Non-standard data types

Non-standard data types are text strings and are stored as 4x registers (40001–4FFFF). The parameters are read using function 03 hex *Read Holding Registers* and written using function 10 hex *Preset Multiple Registers*. Readable sizes range from 1 register (2 characters) up to 10 registers (20 characters).

### 3.8.12 FC Drive Control Profile

#### 3.8.12.1 Control Word According to FC Profile (8-10 Control Profile=FC profile)

3

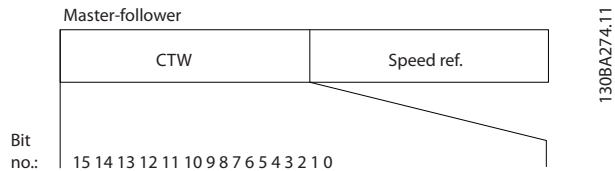


Illustration 3.55 Control Word

Bit	Bit value=0	Bit value=1
00	Reference value	External selection lsb
01	Reference value	External selection msb
02	DC brake	Ramp
03	Coasting	No coasting
04	Quick stop	Ramp
05	Hold output frequency	Use ramp
06	Ramp stop	Start
07	No function	Reset
08	No function	Jog
09	Ramp 1	Ramp 2
10	Data invalid	Data valid
11	No function	Relay 01 active
12	No function	Relay 02 active
13	Parameter set-up	Selection lsb
14	Parameter set-up	Selection msb
15	No function	Reverse

Table 3.43 Control Word Bits

#### Explanation of the Control Bits

##### Bits 00/01

Bits 00 and 01 are used to select between the 4 reference values, which are pre-programmed in 3-10 Preset Reference according to Table 3.44.

Programmed ref. value	Parameter	Bit 01	Bit 00
1	3-10 Preset Reference [0]	0	0
2	3-10 Preset Reference [1]	0	1
3	3-10 Preset Reference [2]	1	0
4	3-10 Preset Reference [3]	1	1

Table 3.44 Reference Values

#### NOTICE

Make a selection in 8-56 Preset Reference Select to define how bit 00/01 gates with the corresponding function on the digital inputs.

##### Bit 02, DC brake

Bit 02=0 leads to DC braking and stop. Set braking current and duration in 2-01 DC Brake Current and 2-02 DC Braking Time.

Bit 02=1 leads to ramping.

##### Bit 03, Coasting

Bit 03=0: The frequency converter immediately releases the motor, (the output transistors are shut off) and it coasts to a standstill.

Bit 03=1: The frequency converter starts the motor, if the other starting conditions are met.

Make a selection in 8-50 Coasting Select to define how bit 03 gates with the corresponding function on a digital input.

##### Bit 04, Quick stop

Bit 04=0: Makes the motor speed ramp down to stop (set in 3-81 Quick Stop Ramp Time).

##### Bit 05, Hold output frequency

Bit 05=0: The present output frequency (in Hz) freezes. Change the frozen output frequency only with the digital inputs (5-10 Terminal 18 Digital Input to 5-15 Terminal 33 Digital Input) programmed to Speed up and Slow down.

#### NOTICE

If freeze output is active, the frequency converter can only be stopped by the following:

- Bit 03 coasting stop
- Bit 02 DC braking
- Digital input (5-10 Terminal 18 Digital Input to 5-15 Terminal 33 Digital Input) programmed to DC braking, Coasting stop, or Reset and coasting stop.

##### Bit 06, Ramp stop/start

Bit 06=0: Causes a stop and makes the motor speed ramp down to stop via the selected ramp down parameter.

Bit 06=1: Permits the frequency converter to start the motor, if the other starting conditions are met.

Make a selection in 8-53 Start Select to define how bit 06 Ramp stop/start gates with the corresponding function on a digital input.

##### Bit 07, Reset

Bit 07=0: No reset.

Bit 07=1: Resets a trip. Reset is activated on the signal's leading edge, for example, when changing from logic 0 to logic 1.

**Bit 08, Jog**

Bit 08=1: The output frequency is determined by 3-19 Jog Speed [RPM].

**Bit 09, Selection of ramp 1/2**

Bit 09=0: Ramp 1 is active (3-41 Ramp 1 Ramp Up Time to 3-42 Ramp 1 Ramp Down Time).

Bit 09=1: Ramp 2 (3-51 Ramp 2 Ramp Up Time to 3-52 Ramp 2 Ramp Down Time) is active.

**Bit 10, Data not valid/Data valid**

Tells the frequency converter whether to use or ignore the control word.

Bit 10=0: The control word is ignored.

Bit 10=1: The control word is used. This function is relevant because the telegram always contains the control word, regardless of the telegram type. Turn off the control word, if it should not be used when updating or reading parameters.

**Bit 11, Relay 01**

Bit 11=0: Relay not activated.

Bit 11=1: Relay 01 activated provided that Control word bit 11 is selected in 5-40 Function Relay.

**Bit 12, Relay 04**

Bit 12=0: Relay 04 is not activated.

Bit 12=1: Relay 04 is activated provided that Control word bit 12 is selected in 5-40 Function Relay.

**Bit 13/14, Selection of set-up**

Use bits 13 and 14 to select from the 4 menu set-ups according to Table 3.45.

Set-up	Bit 14	Bit 13
1	0	0
2	0	1
3	1	0
4	1	1

Table 3.45 Specification of Menu Set-ups

The function is only possible when [9] Multi Set-Ups is selected in 0-10 Active Set-up.

Make a selection in 8-55 Set-up Select to define how bit 13/14 gates with the corresponding function on the digital inputs.

**Bit 15 Reverse**

Bit 15=0: No reversing.

Bit 15=1: Reversing. In the default setting, reversing is set to digital in 8-54 Reversing Select. Bit 15 causes reversing only when Ser. communication, Logic or or Logic and is selected.

3.8.12.2 Status Word According to FC Profile (STW) (8-10 Control Profile=FC profile)

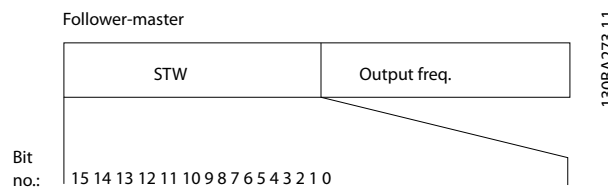


Illustration 3.56 Status Word

Bit	Bit=0	Bit=1
00	Control not ready	Control ready
01	Drive not ready	Drive ready
02	Coasting	Enable
03	No error	Trip
04	No error	Error (no trip)
05	Reserved	-
06	No error	Triplock
07	No warning	Warning
08	Speed ≠ reference	Speed = reference
09	Local operation	Bus control
10	Out of frequency limit	Frequency limit OK
11	No operation	In operation
12	Drive OK	Stopped, auto start
13	Voltage OK	Voltage exceeded
14	Torque OK	Torque exceeded
15	Timer OK	Timer exceeded

Table 3.46 Status Word Bits

**Explanation of the status bits**

**Bit 00, Control not ready/ready**

Bit 00=0: The frequency converter trips.

Bit 00=1: The frequency converter controls are ready but the power component does not necessarily receive any power supply (in case of external 24 V supply to controls).

**Bit 01, Drive ready**

Bit 01=1: The frequency converter is ready for operation but the coasting command is active via the digital inputs or via serial communication.

**Bit 02, Coasting stop**

Bit 02=0: The frequency converter releases the motor.

Bit 02=1: The frequency converter starts the motor with a start command.

**Bit 03, No error/trip**

Bit 03=0 : The frequency converter is not in fault mode.

Bit 03=1: The frequency converter trips. To re-establish operation, enter [Reset].

**Bit 04, No error/error (no trip)**

Bit 04=0: The frequency converter is not in fault mode.

Bit 04=1: The frequency converter shows an error but does not trip.

**Bit 05, Not used**

Bit 05 is not used in the status word.

**Bit 06, No error/triplock**

Bit 06=0: The frequency converter is not in fault mode.  
 Bit 06=1: The frequency converter is tripped and locked.

**Bit 07, No warning/warning**

Bit 07=0: There are no warnings.  
 Bit 07=1: A warning has occurred.

**Bit 08, Speed≠reference/speed=reference**

Bit 08=0: The motor is running, but the present speed is different from the preset speed reference. It might, for example, be the case when the speed ramps up/down during start/stop.  
 Bit 08=1: The motor speed matches the preset speed reference.

**Bit 09, Local operation/bus control**

Bit 09=0: [Stop/Reset] is activated on the control unit or *Local control* in 3-13 Reference Site is selected. Control via serial communication is not possible.  
 Bit 09=1 It is possible to control the frequency converter via the fieldbus/serial communication.

**Bit 10, Out of frequency limit**

Bit 10=0: The output frequency has reached the value in 4-11 Motor Speed Low Limit [RPM] or 4-13 Motor Speed High Limit [RPM].  
 Bit 10=1: The output frequency is within the defined limits.

**Bit 11, No operation/in operation**

Bit 11=0: The motor is not running.  
 Bit 11=1: The frequency converter has a start signal or the output frequency is greater than 0 Hz.

**Bit 12, Drive OK/stopped, autostart**

Bit 12=0: There is no temporary overtemperature on the inverter.  
 Bit 12=1: The inverter stops because of overtemperature, but the unit does not trip and resumes operation once the overtemperature stops.

**Bit 13, Voltage OK/limit exceeded**

Bit 13=0: There are no voltage warnings.  
 Bit 13=1: The DC-voltage in the frequency converter's intermediate circuit is too low or too high.

**Bit 14, Torque OK/limit exceeded**

Bit 14=0: The motor current is lower than the torque limit selected in 4-18 Current Limit.  
 Bit 14=1: The torque limit in 4-18 Current Limit is exceeded.

**Bit 15, Timer OK/limit exceeded**

Bit 15=0: The timers for motor thermal protection and thermal protection are not exceeded 100%.  
 Bit 15=1: One of the timers exceeds 100%.

All bits in the STW are set to 0 if the connection between the interbus option and the frequency converter is lost, or an internal communication problem has occurred.

3.8.12.3 Bus Speed Reference Value

Speed reference value is transmitted to the frequency converter in a relative value in %. The value is transmitted in the form of a 16-bit word; in integers (0–32767) the value 16384 (4000 hex) corresponds to 100%. Negative figures are formatted by means of 2's complement. The actual output frequency (MAV) is scaled in the same way as the bus reference.

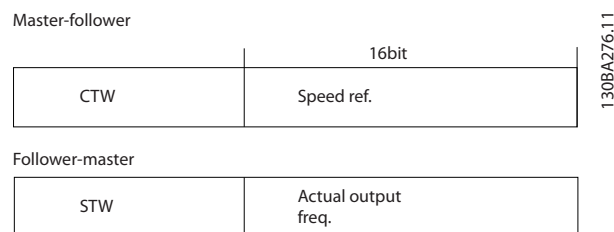


Illustration 3.57 Actual Output Frequency (MAV)

The reference and MAV are scaled as follows:

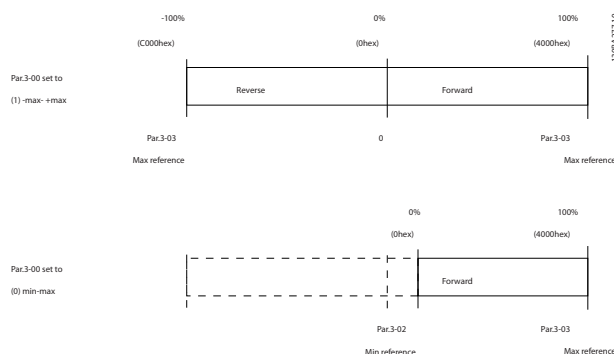


Illustration 3.58 Reference and MAV

### 3.8.12.4 Control Word according to PROFdrive Profile (CTW)

The control word is used to send commands from a master (for example, a PC) to a slave.

Bit	Bit=0	Bit=1
00	Off 1	On 1
01	Off 2	On 2
02	Off 3	On 3
03	Coasting	No coasting
04	Quick stop	Ramp
05	Hold frequency output	Use ramp
06	Ramp stop	Start
07	No function	Reset
08	Jog 1 Off	Jog 1 On
09	Jog 2 Off	Jog 2 On
10	Data invalid	Data valid
11	No function	Slow down
12	No function	Catch up
13	Parameter set-up	Selection lsb
14	Parameter set-up	Selection msb
15	No function	Reverse

Table 3.47 Control Word Bits

#### Explanation of the control bits

##### Bit 00, OFF 1/ON 1

Normal ramp stops using the ramp times of the actual selected ramp.

Bit 00=0 leads to the stop and activation of the output relay 1 or 2 if the output frequency is 0 Hz and if [Relay 123] has been selected in *5-40 Function Relay*.

When bit 0=1, the frequency converter is in State 1: *Switching on inhibited*.

##### Bit 01, Off 2/On 2

Coasting stop

When bit 01=0, a coasting stop and activation of the output relay 1 or 2 occurs if the output frequency is 0 Hz and if [Relay 123] has been selected in *5-40 Function Relay*.

##### Bit 02, Off 3/On 3

Quick stop using the ramp time of *3-81 Quick Stop Ramp Time*. When bit 02=0, a quick stop and activation of the output relay 1 or 2 occurs if the output frequency is 0 Hz and if [Relay 123] has been selected in *5-40 Function Relay*.

When bit 02=1, the frequency converter is in State 1: *Switching on inhibited*.

##### Bit 03, Coasting/No coasting

Coasting stop bit 03=0 leads to a stop.

When bit 03=1, the frequency converter can start if the other start conditions are satisfied.

#### **NOTICE**

The selection in *8-50 Coasting Select* determines how bit 03 is linked with the corresponding function of the digital inputs.

##### Bit 04, Quick stop/Ramp

Quick stop using the ramp time of *3-81 Quick Stop Ramp Time*.

When bit 04=0, a quick stop occurs.

When bit 04=1, the frequency converter can start if the other start conditions are satisfied.

#### **NOTICE**

The selection in *8-51 Quick Stop Select* determines how bit 04 is linked with the corresponding function of the digital inputs.

##### Bit 05, Hold frequency output/Use ramp

When bit 05=0, the current output frequency is being maintained even if the reference value is modified.

When bit 05=1, the frequency converter can perform its regulating function again; operation occurs according to the respective reference value.

##### Bit 06, Ramp stop/Start

Normal ramp stop using the ramp times of the actual ramp as selected. In addition, activation of the output relay 01 or 04 if the output frequency is 0 Hz and if relay 123 has been selected in *5-40 Function Relay*.

Bit 06=0 leads to a stop.

When bit 06=1, the frequency converter can start if the other start conditions are fulfilled.

#### **NOTICE**

The selection in *8-53 Start Select* determines how bit 06 is linked with the corresponding function of the digital inputs.

##### Bit 07, No function/Reset

Reset after switching off.

Acknowledges event in fault buffer.

When bit 07=0, no reset occurs.

When there is a slope change of bit 07 to 1, a reset occurs after switching off.

##### Bit 08, Jog 1 Off/On

Activation of the pre-programmed speed in *8-90 Bus Jog 1 Speed*. JOG 1 is only possible if bit 04=0 and bit 00-03=1.

##### Bit 09, Jog 2 Off/On

Activation of the pre-programmed speed in *8-91 Bus Jog 2 Speed*. Jog 2 is only possible if bit 04=0 and bit 00-03=1.

##### Bit 10, Data invalid/valid

Is used to tell the frequency converter whether the control word is to be used or ignored.

Bit 10=0 causes the control word to be ignored,

Bit 10=1 causes the control word to be used. This function is relevant because the control word is always contained in the telegram, regardless of which type of telegram is used. It is possible to turn off the control word, if it should not be used for updating or reading parameters.

**Bit 11, No function/Slow down**

Is used to reduce the speed reference value by the amount given in 3-12 *Catch up/slow Down Value*.

When bit 11=0, no modification of the reference value occurs.

When bit 11=1, the reference value is reduced.

**Bit 12, No function/Catch up**

Is used to increase the speed reference value by the amount given in 3-12 *Catch up/slow Down Value*.

When bit 12=0, no modification of the reference value occurs.

When bit 12=1, the reference value is increased.

If both slowing down and accelerating are activated (bit 11 and 12=1), slowing down has priority, that is, the speed reference value is reduced.

**Bits 13/14, Set-up selection**

Bits 13 and 14 are used to select between the 4 parameter set-ups according to *Table 3.48*.

The function is only possible if [9] *Multi Set-up* has been selected in 0-10 *Active Set-up*. The selection in 8-55 *Set-up Select* determines how bits 13 and 14 are linked with the corresponding function of the digital inputs. Changing set-up while running is only possible if the set-ups have been linked in 0-12 *This Set-up Linked to*.

Set-up	Bit 13	Bit 14
1	0	0
2	1	0
3	0	1
4	1	1

Table 3.48 Set-up Selection

**Bit 15, No function/Reverse**

Bit 15=0 causes no reversing.

Bit 15=1 causes reversing.

**NOTICE**

In the factory settings reversing is set to *digital* in 8-54 *Reversing Select*.

**NOTICE**

Bit 15 causes reversing only when *Ser. communication, Logic or or Logic and* is selected.

**3.8.12.5 Status Word according to PROFIdrive Profile (STW)**

The status word is used to notify a master (for example, a PC) about the status of a slave.

Bit	Bit=0	Bit=1
00	Control not ready	Control ready
01	Drive not ready	Drive ready
02	Coasting	Enable
03	No error	Trip
04	Off 2	On 2
05	Off 3	On 3
06	Start possible	Start not possible
07	No warning	Warning
08	Speed≠reference	Speed=reference
09	Local operation	Bus control
10	Out of frequency limit	Frequency limit OK
11	No operation	In operation
12	Drive OK	Stopped, autostart
13	Voltage OK	Voltage exceeded
14	Torque OK	Torque exceeded
15	Timer OK	Timer exceeded

Table 3.49 Status Word Bits

**Explanation of the status bits**

**Bit 00, Control not ready/ready**

When bit 00=0, bit 00, 01 or 02 of the control word is 0 (OFF 1, OFF 2 or OFF 3) – or the frequency converter is switched off (trip).

When bit 00=1, the frequency converter control is ready, but there is not necessarily power supply to the unit present (in the event of external 24 V supply of the control system).

**Bit 01, Drive not ready/ready**

Same significance as bit 00, however, there is a supply of the power unit. The frequency converter is ready when it receives the necessary start signals.

**Bit 02, Coasting/Enable**

When bit 02=0, bit 00, 01 or 02 of the control word is 0 (Off 1, Off 2 or Off 3 or coasting) – or the frequency converter is switched off (trip).

When bit 02=1, bit 00, 01 or 02 of the control word is 1; the frequency converter has not tripped.

**Bit 03, No error/Trip**

When bit 03=0, no error condition of the frequency converter exists.

When bit 03=1, the frequency converter has tripped and requires a reset signal before it can start.

**Bit 04, On 2/Off 2**

When bit 01 of the control word is 0, then bit 04=0.

When bit 01 of the control word is 1, then bit 04=1.

**Bit 05, On 3/Off 3**

When bit 02 of the control word is 0, then bit 05=0.

When bit 02 of the control word is 1, then bit 05=1.

**Bit 06, Start possible/Start not possible**

If [1] *PROFD*rive has been selected in 8-10 *Control Profile*, bit 06 is 1 after a switch-off acknowledgment, after activation of Off2 or Off3, and after switching on the mains voltage, *Start not possible* is reset, with bit 00 of the control word is set to 0 and bits 01, 02 and 10 are set to 1.

**Bit 07, No warning/Warning**

Bit 07=0 means that there are no warnings.  
Bit 07=1 means that a warning has occurred.

**Bit 08, Speed≠reference/Speed=reference**

When bit 08=0, the current speed of the motor deviates from the set speed reference value. This may occur, for example, when the speed is being changed during start/stop through ramp up/down.

When bit 08=1, the current speed of the motor corresponds to the set speed reference value.

**Bit 09, Local operation/Bus control**

Bit 09=0 indicates that the frequency converter has been stopped with [Stop] on the LCP, or that [Linked to hand] or [Local] has been selected in 3-13 *Reference Site*.

When bit 09=1, the frequency converter can be controlled through the serial interface.

**Bit 10, Out of frequency limit/Frequency limit OK**

When bit 10=0, the output frequency is outside the limits set in 4-52 *Warning Speed Low* and 4-53 *Warning Speed High*.

When bit 10=1, the output frequency is within the indicated limits.

**Bit 11, No operation/Operation**

When bit 11=0, the motor does not turn.

When bit 11=1, the frequency converter has a start signal, or the output frequency is higher than 0 Hz.

**Bit 12, Drive OK/Stopped, autostart**

When bit 12=0, there is no temporary overloading of the inverter.

When bit 12=1, the inverter has stopped due to overloading. However, the frequency converter has not switched off (trip) and starts again after the overloading has ended.

**Bit 13, Voltage OK/Voltage exceeded**

When bit 13=0, the voltage limits of the frequency converter are not exceeded.

When bit 13=1, the direct voltage in the intermediate circuit of the frequency converter is too low or too high.

**Bit 14, Torque OK/Torque exceeded**

When bit 14=0, the motor torque is below the limit selected in 4-16 *Torque Limit Motor Mode* and 4-17 *Torque Limit Generator Mode*.

When bit 14=1, the limit selected in 4-16 *Torque Limit Motor Mode* or 4-17 *Torque Limit Generator Mode* is exceeded.

**Bit 15, Timer OK/Timer exceeded**

When bit 15=0, the timers for the thermal motor protection and thermal frequency converter protection have not exceeded 100%.

When bit 15=1, one of the timers has exceeded 100%.

### 3.9 System Design Checklist

Table 3.50 provides a checklist for integrating a frequency converter into a motor control system. The list is intended as a reminder of the general categories and options necessary for specifying the system requirements.

**3**

Category	Details	Notes	<input checked="" type="checkbox"/>
FC Model			
<b>Power</b>			
	Volts		
	Current		
<b>Physical</b>			
	Dimensions		
	Weight		
<b>Ambient operating conditions</b>			
	Temperature		
	Altitude		
	Humidity		
	Air quality/dust		
	Derating requirements		
<b>Enclosure size</b>			
<b>Input</b>			
<b>Cables</b>			
	Type		
	Length		
<b>Fuses</b>			
	Type		
	Size		
	Rating		
<b>Options</b>			
	Connectors		
	Contacts		
	Filters		
<b>Output</b>			
<b>Cables</b>			
	Type		
	Length		
<b>Fuses</b>			
	Type		
	Size		
	Rating		
<b>Options</b>			
	Filters		
<b>Control</b>			
<b>Wiring</b>			
	Type		
	Length		
	Terminal connections		
<b>Communication</b>			
	Protocol		
	Connection		
	Wiring		
<b>Options</b>			
	Connectors		



Category	Details	Notes	<input type="checkbox"/>
	Contacts		
	Filters		
<b>Motor</b>			
	Type		
	Rating		
	Voltage		
	Options		
<b>Special tools and equipment</b>			
	Moving and storage		
	Mounting		
	Electrical connection		

3

Table 3.50 System Design Checklist

## 4 Application Examples

### 4.1 Application Feature Overview

The VLT® AQUA Drive FC 202 is designed for water and wastewater applications. The wide range of standard and optional features includes optimised SmartStart and quick menu with a focus on water and wastewater applications:

- **Cascade control**  
Basic cascade control is built-in as standard, with a capacity of up to 3 pumps. Cascade control provides speed control of a single pump in a multi pump system. This is a cost attractive solution, for example for booster sets. Systems with multiple variable speed pumps require the extended cascade controller (MCO 101) or the advanced cascade controller (MCO 102).
- **Motor alternation**  
The motor alternation functionality is suitable for applications with 2 motors or 2 pumps sharing 1 frequency converter.
- **Flow compensation**  
Flow compensation adapts the setpoint according to the flow, and enables mounting of the pressure sensor close to the pump.
- **Dry-run detection**  
The feature prevents damage of the pump by avoiding dry-running and pump overheat
- **End-of-curve detection**  
The feature detects when the pump is running at maximum speed and the setpoint cannot be reached for a user defined time period.
- **Deragging**  
This preventive or reactive cleaning feature is designed for pumps in wastewater applications. See *chapter 4.2.3 29-1\* Deragging Function* for details.
- **Initial/final ramps**  
Programming of short ramp times to/from minimum speed protects bearings, and ensures sufficient cooling in applications with submersible pumps.
- **Check valve protection**  
A slow ramp-down rate protects check valves and prevents water hammering
- **STO**  
STO enables safe stop (coast) when a critical situation arises.
- **Low-flow detection**  
This feature detects no-flow or low-flow conditions of the system.
- **Sleep mode**  
The sleep mode feature saves energy by stopping the pump when there is no demand.
- **Pipe fill mode**  
Pipe fill mode comprises functionalities to fill pipes smoothly and avoid water hammering. This feature provides different modes for horizontal and vertical pipes.
- **Real-time clock**
- **Smart logic control (SLC)**  
SLC comprises programming of a sequence consisting of events and actions. SLC offers a wide range of PLC functions using comparators, logic rules and timers.
- **Pre/post Lube**  
See *chapter 4.2.4 Pre/post Lube* for details.
- **Flow confirmation**  
See *chapter 4.2.5 29-5\* Flow Confirmation* for details.
- **Advanced minimum speed monitoring for submersible pumps**  
See *chapter 4.2.6 Advanced Minimum Speed Monitoring for Submersible Pumps* for details.
- **Preventive maintenance**  
The preventive maintenance feature enables programming of scheduled service intervals into the frequency converter.

### 4.2 Selected Application Features

#### 4.2.1 SmartStart

With the SmartStart wizard, it is now easier and more cost-efficient to commission the frequency converter. SmartStart is activated at the first power up or after a factory reset and guides users through a series of easy steps to ensure the correct and most efficient motor control. The SmartStart can also be started directly via the quick menu. Select settings on the 28-language graphical control panel.

- Single pump/motor in open or closed loop
- Motor alternation: When 2 motors share 1 frequency converter.
- Basic cascade control: Speed control of a single pump in a multi-pump system. This is a cost-attractive solution in, for example, booster sets.
- Master-follower: Control up to 8 frequency converters and pumps to ensure smooth operation of the overall pump system.

### 4.2.2 Quick Menu Water and Pumps

The quick menu entry water and pumps provides quick access to the most common water and pump features of the VLT® AQUA Drive:

- Special ramps (initial/final ramp, check valve ramp)
- Sleep mode
- Deragging
- Dry-run detection
- End of curve detection
- Flow compensation
- Pipe fill mode for horizontal, vertical and mixed pipe systems
- Control performance
- Minimum speed monitor

### 4.2.3 29-1\* Deragging Function

The purpose of the deragging feature is to free the pump blade of debris in waste water applications so that the pump operates normally.

A deragging event is defined as the time when the frequency converter starts to derag to when the deragging finishes. When a derag is started, the frequency converter ramps first to a stop and then an off delay expires before the first cycle begins.

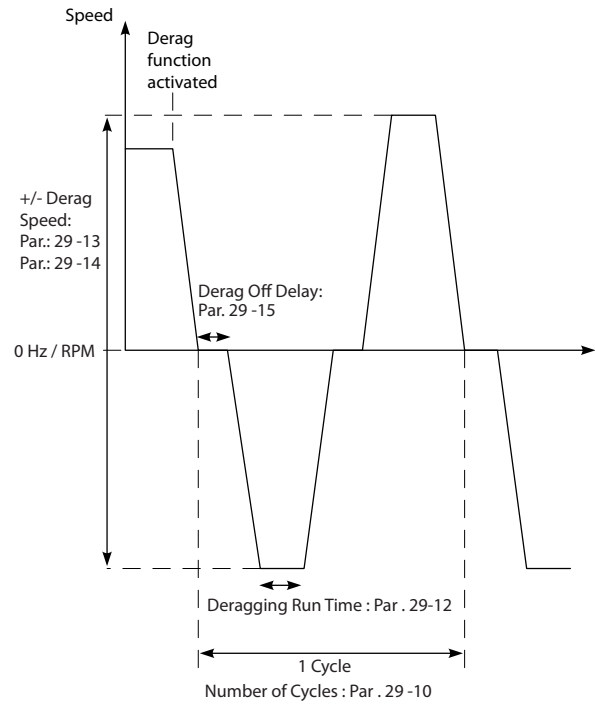


Illustration 4.1 Derag Function

If a derag is triggered from a frequency converter-stopped state, the first off delay is skipped. The deragging event may consist of several cycles. One cycle consisting of one pulse in the reverse direction followed by one pulse in the forward direction. Deragging is considered finished after the specified number of cycles has completed. More specifically, on the last pulse (it will always be forward) of the last cycle, the derag is considered finished after the deragging run time expires (the frequency converter is running at derag speed). In between pulses, the frequency converter output coasts for a specified off delay time to let debris in the pump settle.

#### **NOTICE**

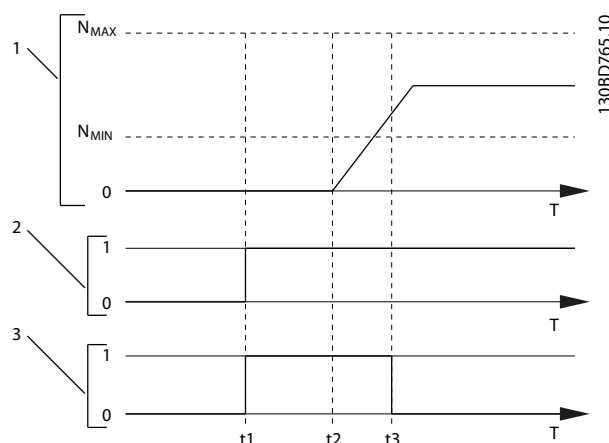
**Do not enable deragging if the pump cannot operate in reverse direction.**

There are 3 different notifications for an ongoing deragging event:

- Status in the LCP: *Auto Remote Derag*.
- A bit in the extended status word (Bit 23, 80 0000 hex).
- A digital output can be configured to reflect the active deragging status.

Depending on the application and the purpose of using it, this feature can be used as a preventive or reactive measure and can be triggered/started in the following ways:

- On each start command (29-11 Derag at Start/ Stop)
- On each stop command (29-11 Derag at Start/ Stop)
- On each start/stop command (29-11 Derag at Start/Stop)
- On digital input (parameter group 5-1\* Digital Inputs)
- On drive action with the smart logic controller (13-52 SL Controller Action)
- As timed action (parameter group 23-\*\* Time-based Functions)
- On high power (parameter group 29-2\* Derag Power Tuning)



1	Speed curve
2	Start command (for example, terminal 18)
3	Pre lube output signal
t <sub>1</sub>	Start command issued (for example, terminal 18 is set active). The start delay timer (1-71 Start Delay) and the pre lube timer (29-41 Pre Lube Time).
t <sub>2</sub>	The start delay timer expires. The frequency converter starts to ramp up.
t <sub>3</sub>	The pre lube timer (29-41 Pre Lube Time) expires.

Illustration 4.2 Pre/post Lube Function Example

### 4.2.4 Pre/post Lube

Certain motors require lubrication of their mechanical parts before and during running to prevent damage/wear. This is especially the case when the motor has not been running for extended periods of time. Pre-lube also supports applications that may require certain exhaust fans to be running. The Pre-lube feature signals an external device to start performing a specific action for a user-defined period of time beginning at the rising edge of a run command (for example, start request). Furthermore, a start delay (1-71 Start Delay) can be entered such that the pre-lube only occurs while the frequency converter is stopped and the pre-lube completes just before the frequency converter starts to ramp up. Pre-lube can also be configured such that the external device remains signalled at all times when the frequency converter is in a running state or such that the signal stays on after the motor has stopped (29-42 Post Lube Time). Application examples include a device to lubricate the mechanical parts of a motor/pump or some type of exhaust fan unit.

An example use case for a lubrication device would be to start lubrication at the rising edge of a start request. Delay the start for a period of time and stop lubrication when the delay expires and the frequency converter starts.

Illustration 4.2 shows a different usage of the feature. In this case, the delay expires while the frequency converter is already ramping up. See the related parameters in Table 4.1.

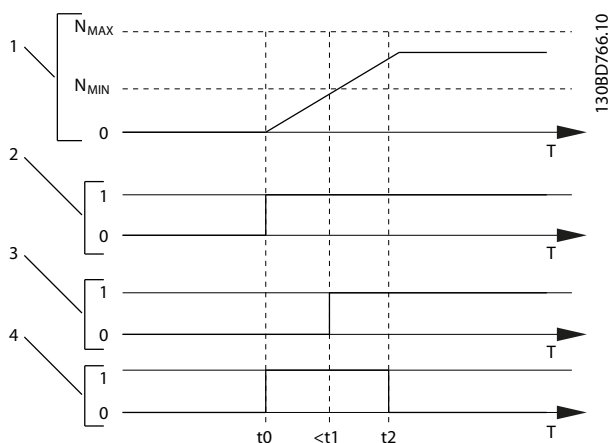
Parameter and Name	Description	Settings	Unit
29-40 Pre/Post Lube Function	Select the pre/post lube function. Use 1-71 Start Delay to set the delay before the motor will start ramping.	[0]*Disabled [1] Pre lube only [2] Pre & running [3] Pre & running & post	-
29-41 Pre Lube Time	Enter the duration of the signal after the start signal. Used only when [1] Pre lube Only is selected in 29-40 Pre/Post Lube Function.	0-600 (*10)	s
29-42 Post Lube Time	Select the duration of the signal after the motor has stopped. Used only when [3] Pre & running & post is selected in 29-40 Pre/Post Lube Function.	0-600 (*10)	s

Table 4.1 Pre/Post Lube Parameters

### 4.2.5 29-5\* Flow Confirmation

The flow confirmation feature is designed for applications where there is a need for the motor/pump to run while waiting for an external event. The flow confirmation monitor expects to get a digital input from a sensor on a gate valve, flow switch, or a similar external device indicating that the device is in the open position and flow is possible. In *29-50 Validation Time*, a user defines how long the VLT® AQUA Drive FC 202 waits for the digital input signal from the external device to confirm the flow. After the flow is confirmed, the frequency converter checks the signal again after the flow verification time and then runs normally. The LCP status reads "Verifying flow" while the flow monitor is active.

The frequency converter trips with the alarm *Flow Not Confirmed*, if the expected digital input signal becomes inactive before either the flow validation time or the flow verification time expires.



1	Speed curve
2	Start command (for example, terminal 18)
3	Digital signal from an external device that confirms that the flow is possible.
4	Flow verification
$t_0$	Start command issued (for example, terminal 18 is set active)
$t_1$	Digital signal from an external device becomes active before <i>29-50 Validation Time</i> expires.
$t_2$	When <i>29-51 Verification Time</i> passes, the frequency converter checks the signal from the external device again and then runs normally.

Illustration 4.3 Flow Confirmation

Parameter and Name	Description	Settings	Unit
<i>29-50 Validation Time</i>	The digital input must be active during the validation time.	0.1–999.0 (*size dependent)	s
<i>29-51 Verification Time</i>	Flow will be confirmed if, at the end of the verification time, the digital input is still active.	0.1–255.0 (*15)	s

Table 4.2 Flow Confirmation Parameters

#### NOTICE

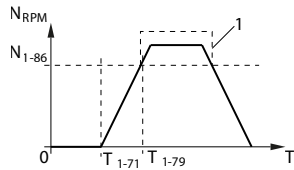
The parameters are only visible on the LCP when a digital input is configured as flow confirmation.

### 4.2.6 Advanced Minimum Speed Monitoring for Submersible Pumps

Some pumps are very sensitive to operating at low speed. Typical reasons for this are insufficient cooling or lubrication at low speed.

Under overload conditions, the frequency converter protects itself using its integral protection features, which include lowering the speed. For example, the current limit controller can lower the speed. This means that, in some cases, the speed may go lower than the speed specified in *4-11 Motor Speed Low Limit [RPM]* and *4-12 Motor Speed Low Limit [Hz]*.

The advanced minimum-speed monitoring feature trips the frequency converter if the speed drops below a certain value. If the pump motor of the pump does not reach the speed specified in *1-86 Trip Speed Low [RPM]* within the time specified in *1-79 Pump Start Max Time to Trip* (ramping up takes too long), the frequency converter trips. Timers for *1-71 Start Delay* and *1-79 Pump Start Max Time to Trip* start at the same time when the start command is issued. For instance, this means that if the value in *1-71 Start Delay* is more than or equal to the value in *1-79 Pump Start Max Time to Trip*, the frequency converter never starts.



T <sub>1-71</sub>	1-71 Start Delay.
T <sub>1-79</sub>	1-79 Pump Start Max Time to Trip. This time includes the time in T <sub>1-71</sub> .
N <sub>1-86</sub>	1-86 Trip Speed Low [RPM]. If the speed drops below this value during normal operation, the frequency converter trips.
1	Normal operation.

- Parameter settings are the regional default values unless otherwise indicated (selected in 0-03 Regional Settings).
- Parameters associated with the terminals and their settings are shown next to the drawings.
- Required switch settings for analog terminals A53 or A54 are also shown.

**NOTICE**

When the optional STO feature is used, a jumper wire may be required between terminal 12 (or 13) and terminal 37 for the frequency converter to operate when using factory default programming values.

Illustration 4.4 Advanced Minimum Speed Monitoring

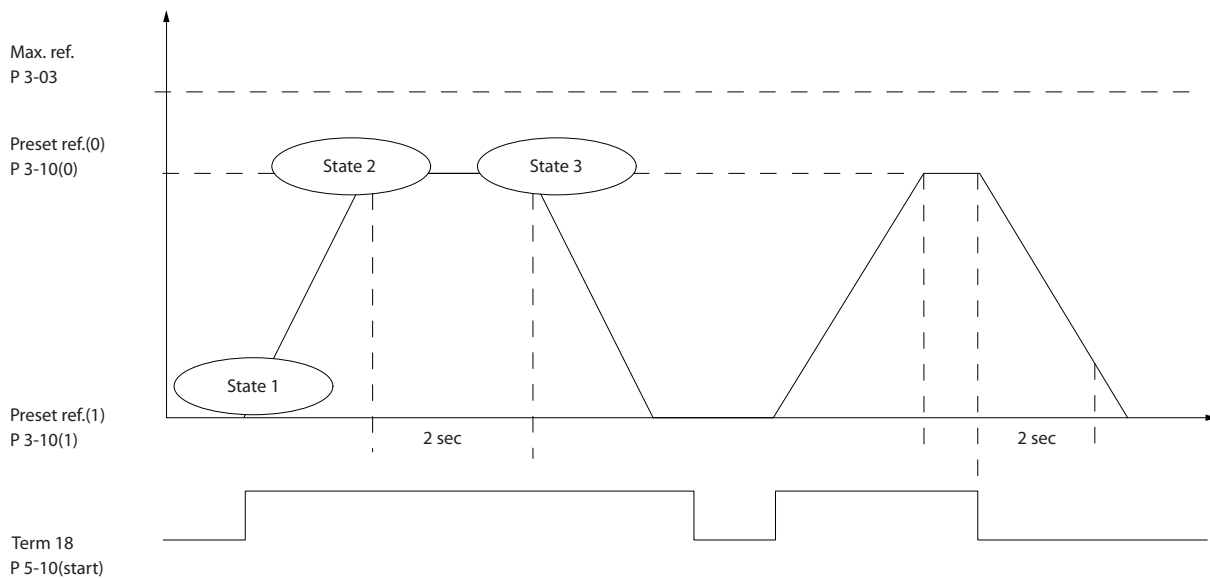
4.3 Application Set-up Examples

The examples in this section are intended as a quick reference for common applications.

SLC Application Example

One sequence 1:

1. Start.
2. Ramp up.
3. Run at reference speed 2 s.
4. Ramp down.
5. Hold shaft until stop.



130BA157.11

Illustration 4.5 Ramp Up/Ramp Down

Set the ramping times in 3-41 Ramp 1 Ramp Up Time and 3-42 Ramp 1 Ramp Down Time to the desired times

$$tramp = \frac{t_{acc} \times n_{norm} (par. 1 - 25)}{ref [RPM]}$$

Set terminal 27 to [0] No Operation (5-12 Terminal 27 Digital Input)

Set preset reference 0 to first preset speed (3-10 Preset Reference [0]) in percentage of maximum reference speed (3-03 Maximum Reference). Example: 60%

Set preset reference 1 to second preset speed (3-10 Preset Reference [1] Example: 0% (zero).

Set the timer 0 for constant running speed in 13-20 SL Controller Timer [0]. Example: 2 s

Set Event 1 in 13-51 SL Controller Event [1] to [1] True.

Set Event 2 in 13-51 SL Controller Event [2] to [4] On Reference.

Set Event 3 in 13-51 SL Controller Event [3] to [30] Time Out 0.

Set Event 4 in 13-51 SL Controller Event [4] to [0] False.

Set Action 1 in 13-52 SL Controller Action [1] to [10] Select preset 0.

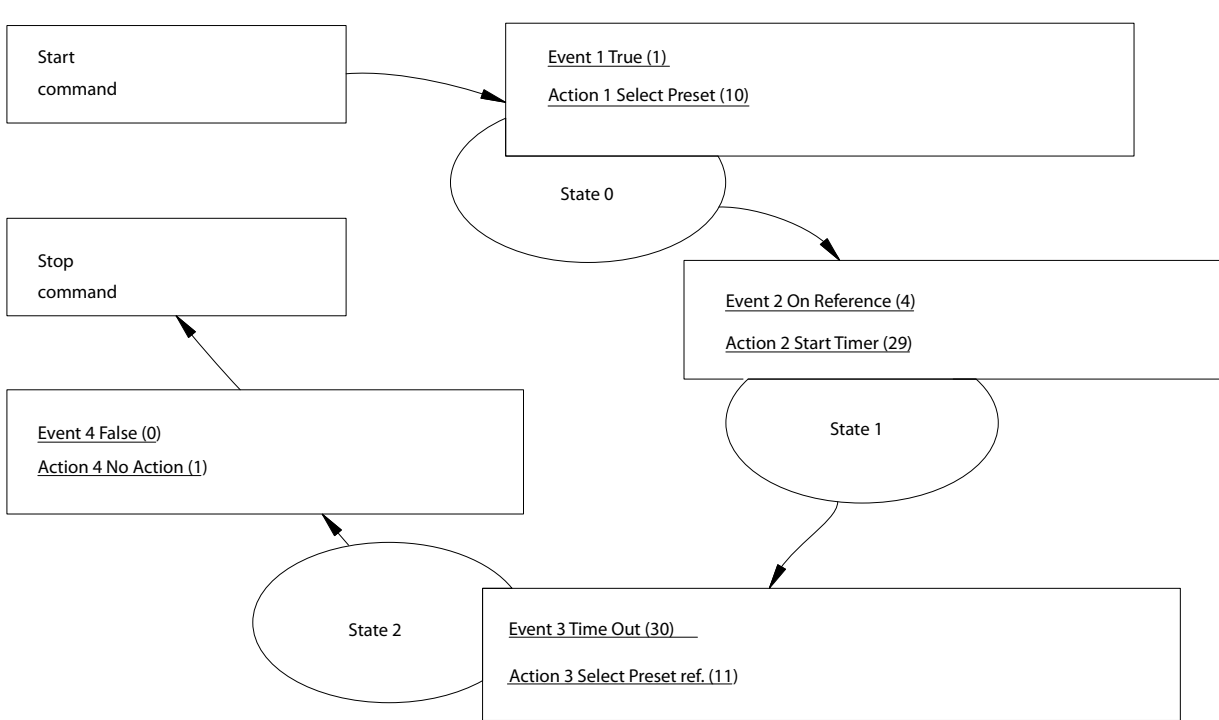
Set Action 2 in 13-52 SL Controller Action [2] to [29] Start Timer 0.

Set Action 3 in 13-52 SL Controller Action [3] to [11] Select preset 1.

Set Action 4 in 13-52 SL Controller Action [4] to [1] No Action.

Set the in 13-00 SL Controller Mode to ON.

Start/stop command is applied on terminal 18. If the stop signal is applied, the frequency converter ramps down and goes into free mode.



130BA148.12

Illustration 4.6 SLC Application Example

### 4.3.1 Submersible Pump Application

The system consists of a submersible pump controlled by a Danfoss VLT® AQUA Drive and a pressure transmitter. The transmitter gives a 4-20 mA feedback signal to the frequency converter, which keeps a constant pressure by controlling the speed of the pump. To design a frequency converter for a submersible pump application, there are a few important issues to consider. Select the frequency converter according to motor current.

1. The motor is a so-called *CAN motor* with a stainless steel can between the rotor and stator. There is a larger and a more magnetic resistant air-gap than on a normal motor, hence a weaker field, which results in the motors being designed with a higher rated current than a normal motor with similar rated power.
2. The pump contains thrust bearings that are damaged when running below minimum speed, which is normally 30 Hz.
3. The motor reactance is nonlinear in submersible pump motors and, therefore, automatic motor adaption (AMA) may not be possible. Normally, submersible pumps are operated with long motor cables that might eliminate the nonlinear motor reactance and enable the frequency converter to perform AMA. If AMA fails, the motor data can be set from parameter group 1-3\* *Adv. Motor Data* (see the motor datasheet). Be aware that, if AMA has succeeded, the frequency converter will compensate for the voltage drop in the long motor cables, so if the advanced motor data are set manually, the length of the motor cable must be considered to optimise system performance.
4. It is important that the system be operated with a minimum of wear and tear on the pump and motor. A Danfoss sine-wave filter can lower the motor insulation stress and increase lifetime (check actual motor insulation and the frequency converter dU/dt specification). Note that most manufacturers of submersible pumps require the use of output filters.
5. EMC performance can be difficult to achieve due to the fact that the special pump cable, which is able to withstand the wet conditions in the well is normally unscreened. A solution could be to use a screened cable above the well and fix the screen to the well pipe if it is made of steel. A sine-wave filter also reduces the EMI from unscreened motor cables.

The special CAN motor is used due to the wet installation conditions. The frequency converter needs to be designed for the system according to output current to be able to run the motor at nominal power.

To prevent damage to the thrust bearings of the pump, and to ensure sufficient motor cooling as quickly as possible, it is important to ramp the pump from stop to minimum speed as quick as possible. Well-known manufacturers of submersible pumps recommend that the pump is ramped to min. speed (30 Hz) in max. 2-3 s. The VLT® AQUA Drive FC 202 is designed with initial and final ramp for these applications. The initial and final ramps are 2 individual ramps, where initial ramp, if enabled, ramps the motor from stop to minimum speed and automatically switches to normal ramp, when minimum speed is reached. Final ramp will do the opposite from minimum speed to stop in a stop situation. Consider also enabling advanced minimum speed monitoring as described in *chapter 4.2 Selected Application Features*.

To achieve additional pump protection, use the dry-run detection function. Refer to the *programming guide* for further information.

Pipe-fill mode can be enabled to prevent water hammering. The Danfoss frequency converter is capable of filling vertical pipes using the PID controller to ramp up the pressure slowly with a user specified rate (units/second). If enabled, the frequency converter enters pipe-fill mode when it reaches minimum speed after start-up. The pressure is slowly ramped up until it reaches a user-specified filled set point, where the frequency converter automatically disables pipe fill mode and continues in normal closed-loop operation.

#### Electrical Wiring

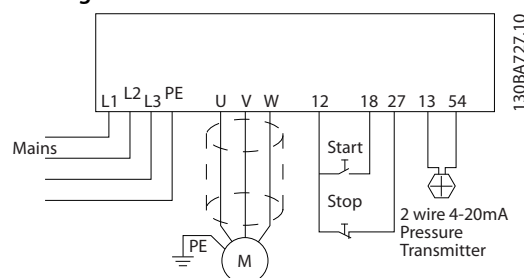


Illustration 4.7 Wiring for Submersible Pump Application



**NOTICE**

Set the analog input 2, (terminal 54) format to mA. (switch 202).

**Parameter Settings**

Parameter
1-20 Motor Power [kW]/1-21 Motor Power [HP]
1-22 Motor Voltage
1-24 Motor Current
1-28 Motor Rotation Check
Enable reduced automatic motor adaptation in 1-29 Automatic Motor Adaptation (AMA)

**Table 4.3 Relevant Parameters for Submersible Pump Application**

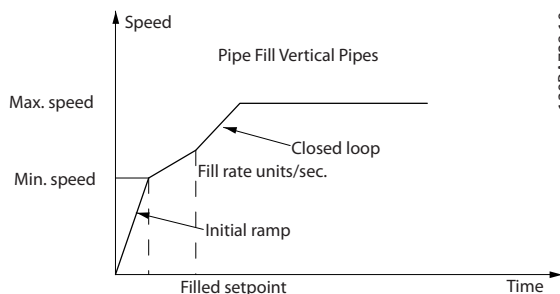
Parameter	Setting
3-02 Minimum Reference	The minimum reference unit matches the unit in 20-12 Reference/Feedback Unit
3-03 Maximum Reference	The maximum reference unit matches the unit in 20-12 Reference/Feedback Unit
3-84 Initial Ramp Time	(2 s)
3-88 Final Ramp Time	(2 s)
3-41 Ramp 1 Ramp Up Time	(8 s depending on size)
3-42 Ramp 1 Ramp Down Time	(8 s depending on size)
4-11 Motor Speed Low Limit [RPM]	(30 Hz)
4-13 Motor Speed High Limit [RPM]	(50/60 Hz)
Use the <i>Closed-loop wizard</i> under <i>Quick Menu_Function_Set-up</i> , to easily set up the feedback settings in the PID controller.	

**Table 4.4 Example of Settings for Submersible Pump Application**

Parameter	Setting
29-00 Pipe Fill Enable	
29-04 Pipe Fill Rate	(Feedback units/s)
29-05 Filled Setpoint	(Feedback units)

**Table 4.5 Example of Settings for Pipe-Fill Mode**

**Performance**

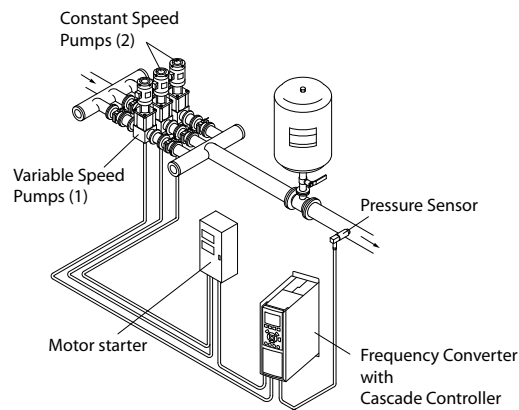


**Illustration 4.8 Pipe Fill-Mode, Performance Curve**

**4.3.2 BASIC Cascade Controller**

The BASIC cascade controller is used for pump applications where a certain pressure (head) or level must be maintained over a wide dynamic range. Running a large pump at variable speed over a wide range is not an ideal solution because of low pump efficiency at lower speed. In a practical way, the limit is 25% of the rated full-load speed for the pump.

In the BASIC cascade controller, the frequency converter controls a variable speed (lead) motor as the variable speed pump and can stage up to 2 additional constant speed pumps on and off. Connect the additional constant speed pumps directly to mains or via soft starters. By varying the speed of the initial pump, variable speed control of the entire system is provided. The variable speed maintains constant pressure, which results in reduced system stress, and quieter operation in pumping systems.



**Illustration 4.9 BASIC Cascade Controller**

**Fixed lead pump**

The motors must be of equal size. The BASIC cascade controller allows the frequency converter to control up to 3 equal pumps using the frequency converter's 2 built-in relays. When the variable pump (lead) is connected directly to the frequency converter, the 2 built-in relays control the other two pumps. When lead pump alternations are enabled, pumps are connected to the built-in relays and the frequency converter can operate 2 pumps.

**Lead pump alternation**

The motors must be of equal size. This function makes it possible to cycle the frequency converter between the pumps in the system (maximum of 2 pumps). In this operation, the run time between pumps is equalised, reducing the required pump maintenance and increasing reliability and lifetime of the system. The alternation of the lead pump can take place at a command signal or at staging (adding another pump).

The command can be a manual alternation or an alternation event signal. If the alternation event is selected, the lead pump alternation takes place every time the event occurs. Selections include:

- Whenever an alternation timer expires;
- at a predefined time of day;
- or when the lead pump goes into sleep mode.

The actual system load determines staging.

A separate parameter limits alternation only to take place if total capacity required is >50%. Total pump capacity is determined as lead pump plus fixed speed pumps capacities.

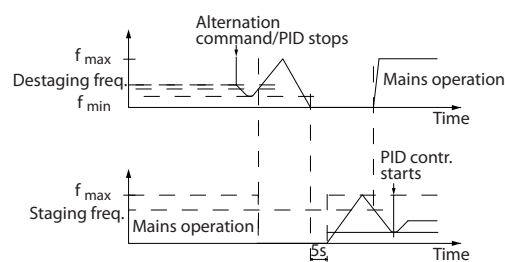
#### Bandwidth management

In cascade control systems, to avoid frequent switching of fixed speed pumps, the desired system pressure is kept within a bandwidth rather than at a constant level. The staging bandwidth provides the required bandwidth for operation. When a large and quick change in system pressure occurs, the override bandwidth overrides the staging bandwidth to prevent immediate response to a short duration pressure change. An override bandwidth timer can be programmed to prevent staging until the system pressure has stabilised and normal control is established.

When the cascade controller is enabled and the frequency converter issues a trip alarm, the system head is maintained by staging and destaging fixed speed pumps. To prevent frequent staging and destaging and minimise pressure fluctuations, a wider fixed speed bandwidth is used instead of the staging bandwidth.

#### 4.3.3 Pump Staging with Lead Pump Alternation

With lead pump alternation enabled, a maximum of 2 pumps are controlled. At an alternation command, the PID stops, the lead pump ramps to minimum frequency ( $f_{\min}$ ) and, after a delay, it ramps to maximum frequency ( $f_{\max}$ ). When the speed of the lead pump reaches the de-staging frequency, the fixed speed pump is cut out (de-staged). The lead pump continues to ramp up and then ramps down to a stop and the 2 relays are cut out.



130BA364:10

Illustration 4.10 Lead Pump Alternation

After a time delay, the relay for the fixed speed pump cuts in (staged) and this pump becomes the new lead pump. The new lead pump ramps up to maximum speed and then down to minimum speed. When ramping down and reaching the staging frequency, the old lead pump is now cut in (staged) on the mains as the new fixed-speed pump.

If the lead pump has been running at minimum frequency ( $f_{\min}$ ) for a programmed amount of time, with a fixed speed pump running, the lead pump contributes little to the system. When programmed value of the timer expires, the lead pump is removed, avoiding water heating problems.

#### 4.3.4 System Status and Operation

If the lead pump goes into sleep mode, the function is displayed on the LCP. It is possible to alternate the lead pump on a sleep mode condition.

When the cascade controller is enabled, the operation status for each pump and the cascade controller is displayed on the LCP. Information displayed includes:

- Pumps status is a readout of the status for the relays assigned to each pump. The display shows pumps that are disabled, off, running on the frequency converter or running on the mains/motor starter.
- Cascade status is a readout of the status for the cascade controller. The display shows that the cascade controller is disabled, all pumps are off, and emergency has stopped all pumps, all pumps are running, fixed speed pumps are being staged/de-staged and lead pump alternation is occurring.
- De-stage at no-flow ensures that all fixed-speed pumps are stopped individually until the no-flow status disappears.

### 4.3.5 Cascade Controller Wiring Diagram

Illustration 4.11 shows an example with the built-in BASIC cascade controller with 1 variable-speed pump (lead) and 2 fixed-speed pumps, a 4–20 mA transmitter and system safety interlock.

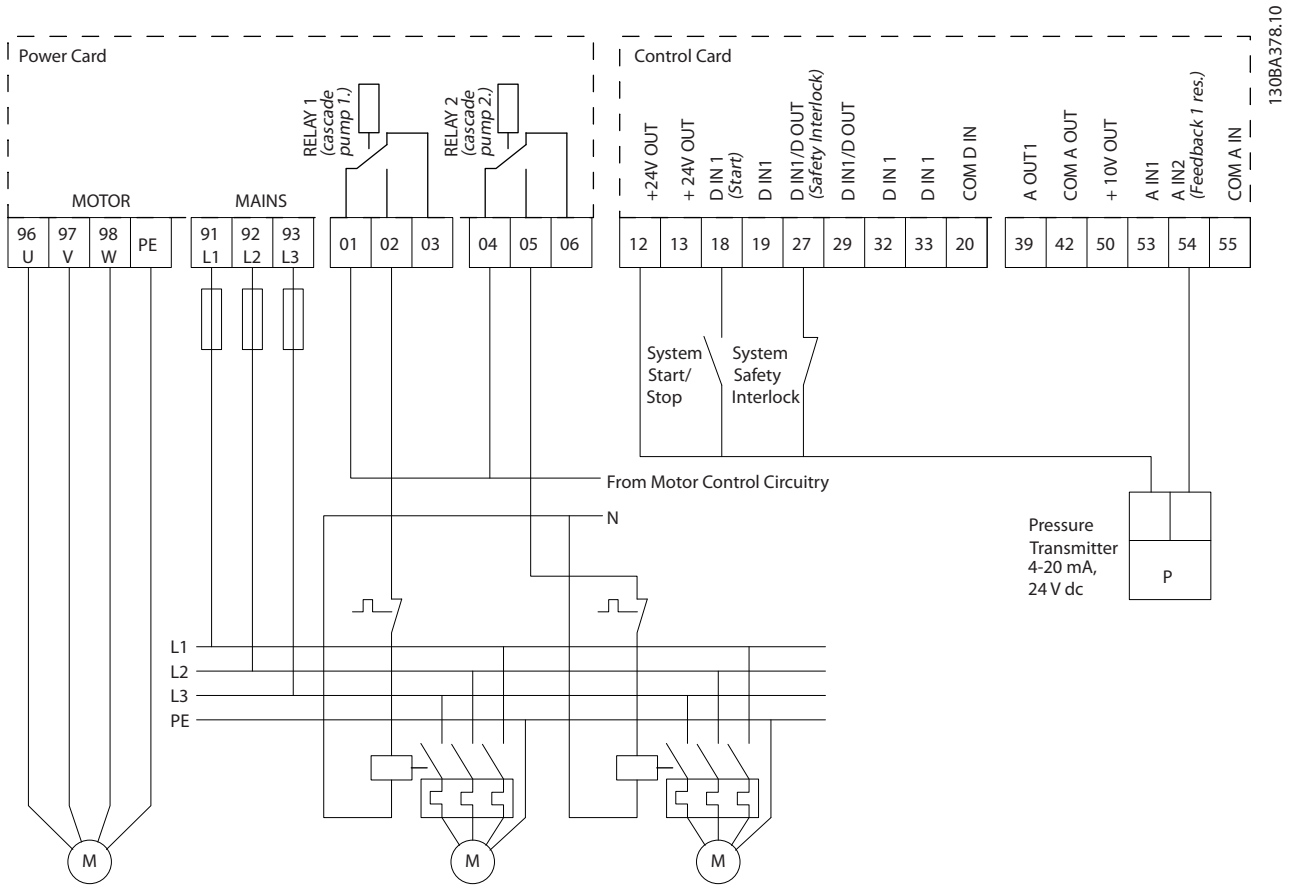


Illustration 4.11 Cascade Controller Wiring Diagram

### 4.3.6 Fixed Variable Speed Pump Wiring Diagram

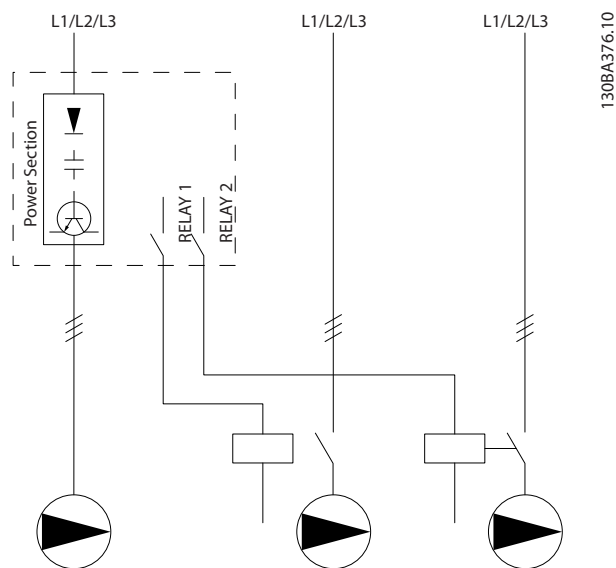


Illustration 4.12 Fixed Variable Speed Pump Wiring Diagram

- K1 blocks for K2 via the mechanical interlock, preventing mains from being connected to the output of the frequency converter (via K1).
- Auxiliary break contact on K1 prevents K3 from cutting in.
- Relay 2 controls contactor K4 for on/off control of the fixed speed pump.
- At alternation, both relays de-energise and now Relay 2 is energised as the first relay.

For a detailed description of commissioning for mixed pump and master/slave applications, refer to *VL7<sup>®</sup> Cascade Controller Options MCO 101/102 Operating Instructions*.

### 4.3.7 Lead Pump Alternation Wiring Diagram

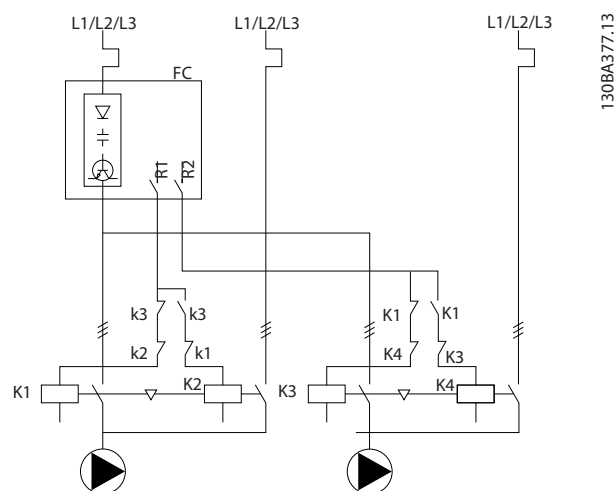


Illustration 4.13 Lead Pump Alternation Wiring Diagram

Every pump must be connected to 2 contactors (K1/K2 and K3/K4) with a mechanical interlock. Thermal relays or other motor protection devices must be applied according to local regulation and/or individual demands.

- Relay 1 (R1) and Relay 2 (R2) are the built-in relays in the frequency converter.
- When all relays are de-energised, the first built-in relay that is energised cuts in the contactor corresponding to the pump controlled by the relay. For example, Relay 1 cuts in contactor K1, which becomes the lead pump.

### 4.3.8 External Alarm Reset

		Parameters	
		Function	Setting
		5-11 Terminal 19 Digital Input * = Default value	[1] Reset
		<b>Notes/comments:</b> D IN 37 is an option.	

Table 4.6 External Alarm Reset

4.3.9 Feedback

		Parameters	
FC		Function	Setting
+24 V	12	6-22 Terminal 54 Low Current	4 mA*
+24 V	13	6-23 Terminal 54 High Current	20 mA*
D IN	18	6-24 Terminal 54 Low Ref./Feedb. Value	0*
D IN	19	6-25 Terminal 54 High Ref./Feedb. Value	50*
COM	20	* = Default value	
D IN	27	<b>Notes/comments:</b> D IN 37 is an option.	
D IN	29		
D IN	32		
D IN	33		
D IN	37		
+10 V	50		
A IN	53		
A IN	54		
COM	55		
A OUT	42		
COM	39		

Table 4.7 Analog Current Feedback Transducer

		Parameters	
FC		Function	Setting
+24 V	12	6-20 Terminal 54 Low Voltage	0.07 V*
+24 V	13	6-21 Terminal 54 High Voltage	10 V*
D IN	18	6-24 Terminal 54 Low Ref./Feedb. Value	0*
D IN	19	6-25 Terminal 54 High Ref./Feedb. Value	50*
COM	20	* = Default value	
D IN	27	<b>Notes/comments:</b> D IN 37 is an option.	
D IN	29		
D IN	32		
D IN	33		
D IN	37		
+10 V	50		
A IN	53		
A IN	54		
COM	55		
A OUT	42		
COM	39		

Table 4.8 Analog Voltage Feedback Transducer (3-wire)

		Parameters	
FC		Function	Setting
+24 V	12	6-20 Terminal 54 Low Voltage	0.07 V*
+24 V	13	6-21 Terminal 54 High Voltage	10 V*
D IN	18	6-24 Terminal 54 Low Ref./Feedb. Value	0*
D IN	19	6-25 Terminal 54 High Ref./Feedb. Value	50*
COM	20	* = Default value	
D IN	27	<b>Notes/comments:</b> D IN 37 is an option.	
D IN	29		
D IN	32		
D IN	33		
D IN	37		
+10 V	50		
A IN	53		
A IN	54		
COM	55		
A OUT	42		
COM	39		

Table 4.9 Analog Voltage Feedback Transducer (4-wire)

4.3.10 Speed

		Parameters	
FC		Function	Setting
+24 V	12	6-10 Terminal 53 Low Voltage	0.07 V*
+24 V	13	6-11 Terminal 53 High Voltage	10 V*
D IN	18	6-14 Terminal 53 Low Ref./Feedb. Value	0 Hz
D IN	19	6-15 Terminal 53 High Ref./Feedb. Value	50 Hz
COM	20	* = Default value	
D IN	27	<b>Notes/comments:</b> D IN 37 is an option.	
D IN	29		
D IN	32		
D IN	33		
D IN	37		
+10 V	50		
A IN	53		
A IN	54		
COM	55		
A OUT	42		
COM	39		

Table 4.10 Analog Speed Reference (Voltage)

		Parameters	
FC		Function	Setting
+24 V	12	6-12 Terminal 53	4 mA*
+24 V	13	Low Current	
D IN	18	6-13 Terminal 53	20 mA*
D IN	19	High Current	
COM	20	6-14 Terminal 53	0 Hz
D IN	27	Low Ref./Feedb.	
D IN	29	Value	
D IN	32	6-15 Terminal 53	50 Hz
D IN	33	High Ref./Feedb.	
D IN	37	Value	
		* = Default value	
		<b>Notes/comments:</b> D IN 37 is an option.	

Table 4.11 Analog Speed Reference (Current)

4.3.11 Run/Stop

		Parameters	
FC		Function	Setting
+24 V	12	5-10 Terminal 18	[8] Start*
+24 V	13	Digital Input	
D IN	18	5-12 Terminal 27	[7] External interlock
D IN	19	Digital Input	
COM	20	* = Default value	
		<b>Notes/comments:</b> D IN 37 is an option.	

Table 4.13 Run/Stop Command with External Interlock

		Parameters	
FC		Function	Setting
+24 V	12	6-10 Terminal 53	0.07 V*
+24 V	13	Low Voltage	
D IN	18	6-11 Terminal 53	10 V*
D IN	19	High Voltage	
COM	20	6-14 Terminal 53	0 Hz
D IN	27	Low Ref./Feedb.	
D IN	29	Value	
D IN	32	6-15 Terminal 53	1500 Hz
D IN	33	High Ref./Feedb.	
D IN	37	Value	
		* = Default value	
		<b>Notes/comments:</b> D IN 37 is an option.	

Table 4.12 Speed Reference (Using a Manual Potentiometer)

		Parameters	
FC		Function	Setting
+24 V	12	5-10 Terminal 18	[8] Start*
+24 V	13	Digital Input	
D IN	18	5-12 Terminal 27	[7] External interlock
D IN	19	Digital Input	
COM	20	* = Default value	
		<b>Notes/comments:</b> If parameter 5-12 Terminal 27 Digital Input is set to [0] no operation, a jumper wire to terminal 27 is not needed. D IN 37 is an option.	

Table 4.14 Run/Stop Command without External Interlock

		Parameters	
FC		Function	Setting
+24 V	120	5-10 Terminal 18 <i>Digital Input</i>	[8] Start*
+24 V	130		
D IN	180	5-11 Terminal 19 <i>Digital Input</i>	[52] Run Permissive
D IN	190		
COM	200	5-12 Terminal 27 <i>Digital Input</i>	[7] External interlock
D IN	270		
D IN	290	5-40 Function <i>Relay</i>	[167] Start command act.
D IN	320		
D IN	330		
D IN	370		
		* = Default value	
		<b>Notes/comments:</b> D IN 37 is an option.	
+10 V	500		
A IN	530		
A IN	540		
COM	550		
A OUT	420		
COM	390		
R1	010		
	020		
	030		
R2	040		
	050		
	060		

Table 4.15 Run Permissive

		Parameters	
VLT		Function	Setting
+24 V	120	1-90 Motor Thermal Protection	[2] Thermistor trip
+24 V	130		
D IN	180		
D IN	190	1-93 Thermistor Source	[1] Analog input 53
COM	200	* = Default Value	
D IN	270		
D IN	290		
D IN	320		
D IN	330		
D IN	370		
		<b>Notes/comments:</b> If only a warning is desired, parameter <i>1-90 Motor Thermal Protection</i> should be set to [1] <i>Thermistor warning</i> . D IN 37 is an option.	
+10 V	500		
A IN	530		
A IN	540		
COM	550		
A OUT	420		
COM	390		
		U - I A53	

Table 4.16 Motor Thermistor

### 4.3.12 Motor Thermistor

## ⚠ WARNING

### THERMISTOR INSULATION

Risk of personal injury or equipment damage.

- Use only thermistors with reinforced or double insulation to meet PELV insulation requirements.

## 5 Special Conditions

This section provides detailed data regarding the operating of the frequency converter in conditions that require derating. In some conditions, derating is performed manually. In other conditions, the frequency converter performs a degree of automatic derating when necessary. Derating ensures proper performance at critical stages where the alternative can be a trip.

### 5.1 Manual Derating

#### 5.1.1 When to Consider Derating

Consider derating when any of the following conditions are present:

- Operating above 1000 m (low air pressure)
- Low-speed operation
- Long motor cables
- Cables with a large cross-section
- High ambient temperature

For more information, refer to *chapter 5.3 Derating for Ambient Temperature*.

#### 5.1.2 Derating for Running at Low Speed

When a motor is connected to a frequency converter, it is necessary to check that the cooling of the motor is adequate.

The level of heating depends on the load on the motor, as well as the operating speed and time.

##### Constant torque applications (CT mode)

A problem may occur at low RPM values in constant torque applications. In a constant torque application, a motor may overheat at low speeds due to less cooling air from the motor integral fan.

Therefore, if the motor is to be run continuously at an RPM value lower than half the rated value, the motor must be supplied with additional air cooling (or a motor designed for this type of operation may be used).

An alternative is to reduce the load level of the motor by selecting a larger motor. However, the design of the frequency converter puts a limit on the motor size.

##### Variable (quadratic) torque applications (VT)

In VT applications such as centrifugal pumps and fans, where the torque is proportional to the square of the speed and the power is proportional to the cube of the speed, there is no need for additional cooling or derating of the motor.

### 5.1.3 Derating for Low Air Pressure

The cooling capability of air is decreased at lower air pressure.

Below 1000 m altitude, no derating is necessary. At altitudes above 1000 m, derate the maximum output current ( $I_{out}$ ) at ambient temperature ( $T_{AMB}$ ) in accordance with *Illustration 5.1*. At altitudes above 2000 m, contact Danfoss regarding PELV.

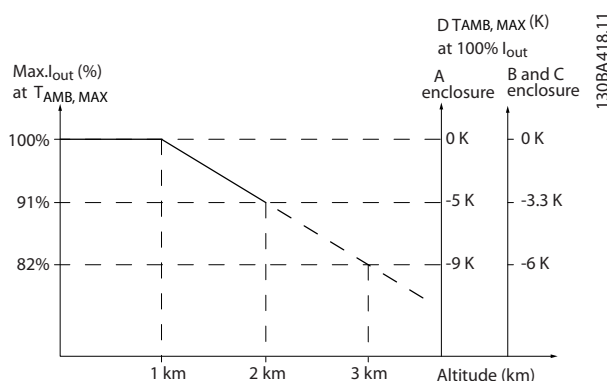


Illustration 5.1 Derating of Output Current versus Altitude at  $T_{AMB, MAX}$  for Enclosure Sizes A, B and C.

An alternative is to lower the ambient temperature at high altitudes and thereby ensure 100% output current at high altitudes. As an example of how to read the graph, the situation at 2000 m is elaborated for an enclosure size B with  $T_{AMB, MAX} = 50\text{ }^\circ\text{C}$ . At a temperature of  $45\text{ }^\circ\text{C}$  ( $T_{AMB, MAX} - 3.3\text{ K}$ ), 91% of the rated output current is available. At a temperature of  $41.7\text{ }^\circ\text{C}$ , 100% of the rated output current is available.

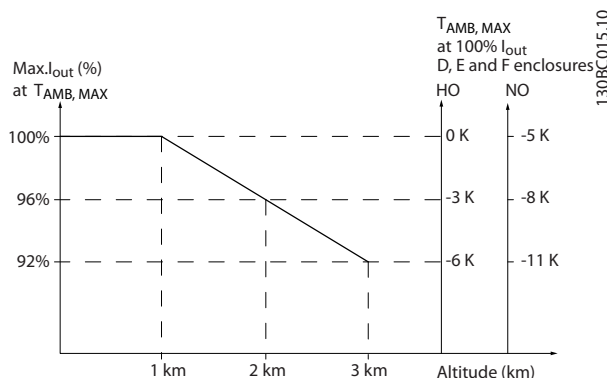


Illustration 5.2 Derating of Output Current versus Altitude at  $T_{AMB, MAX}$  for Enclosure Sizes D3h.



## 5.2 Derating for Long Motor Cables or Cables with Larger Cross-Section

### NOTICE

Applicable for frequency converters up to 90 kW only. The maximum cable length for this frequency converter is 300 m unscreened and 150 m screened cable. The frequency converter has been designed to work using a motor cable with a rated cross-section. If a cable with a larger cross-section is used, reduce the output current by 5% for every step the cross-section is increased. Increased cable cross-section leads to increased capacity to earth, and thus an increased earth leakage current.

## 5.3 Derating for Ambient Temperature

The average temperature ( $T_{AMB,AVG}$ ) measured over 24 hours must be at least 5 °C lower than the maximum permitted ambient temperature ( $T_{AMB,MAX}$ ). If the frequency converter operates at high ambient temperatures, then decrease the continuous output current. Derating depends on the switching pattern, which can be set to 60° AVM or SFAVM in *14-00 Switching Pattern*.

### 5.3.1 Derating for Ambient Temperature, Enclosure Size A

#### 60° AVM – Pulse Width Modulation

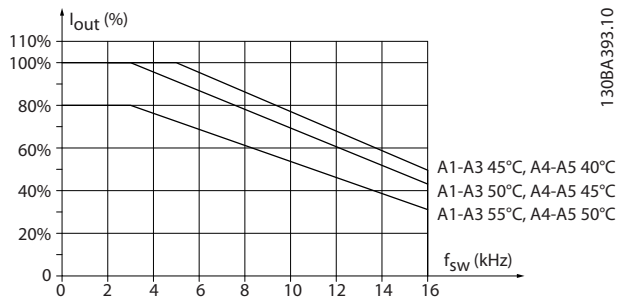


Illustration 5.3 Derating of  $I_{out}$  for Different  $T_{AMB, MAX}$  for Enclosure Size A, using 60° AVM

#### SFAVM – Stator Frequency Asynchron Vector Modulation

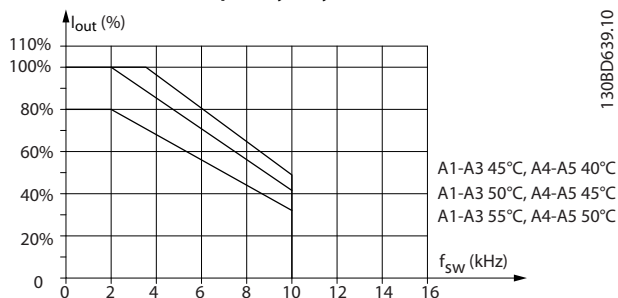


Illustration 5.4 Derating of  $I_{out}$  for Different  $T_{AMB, MAX}$  for Enclosures Type A, using SFAVM

When using only 10 m motor cable or less in enclosure size A, less derating is necessary. This is due to the fact that the length of the motor cable has a relatively high impact on the recommended derating.

#### 60° AVM

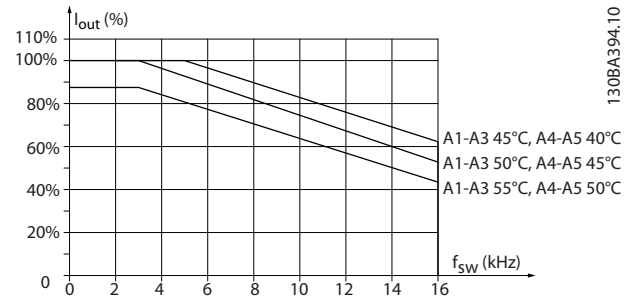


Illustration 5.5 Derating of  $I_{out}$  for Different  $T_{AMB, MAX}$  for Enclosures Type A, using 60° AVM and Maximum 10 m Motor Cable

#### SFAVM

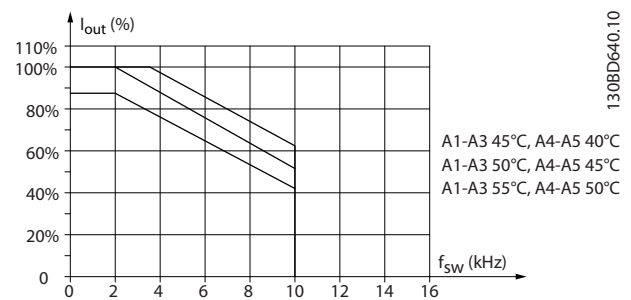


Illustration 5.6 Derating of  $I_{out}$  for Different  $T_{AMB, MAX}$  for Enclosures Type A, using SFAVM and Maximum 10 m Motor Cable

### 5.3.2 Derating for Ambient Temperature, Enclosure Size B

#### Enclosure B, T2, and T4

#### 60° AVM – Pulse Width Modulation

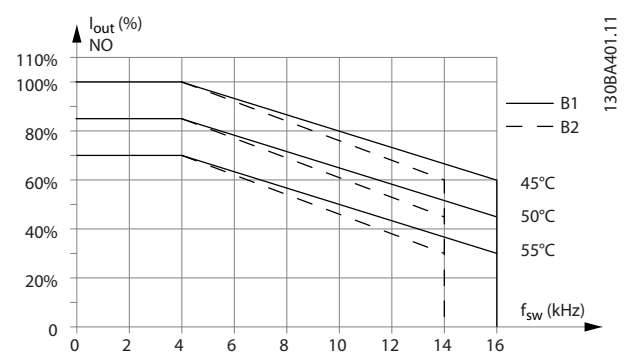


Illustration 5.7 Derating of  $I_{out}$  for different  $T_{AMB, MAX}$  for Enclosure Sizes B1 and B2, using 60° AVM in Normal Overload Mode (110% Overtorque)

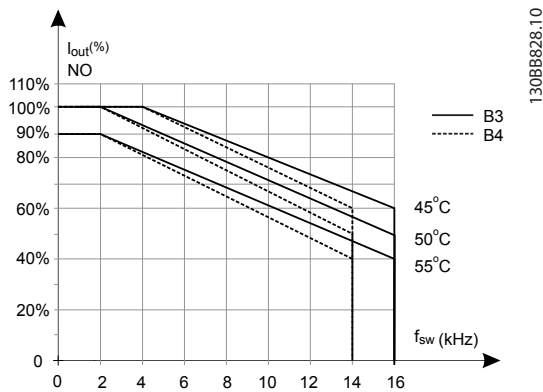


Illustration 5.8 Derating of  $I_{out}$  for different  $T_{AMB, MAX}$  for Enclosure Sizes B3 and B4, using 60° AVM in Normal Overload Mode (110% Overtorque)

Enclosures B, T6  
60° AVM – Pulse Width Modulation

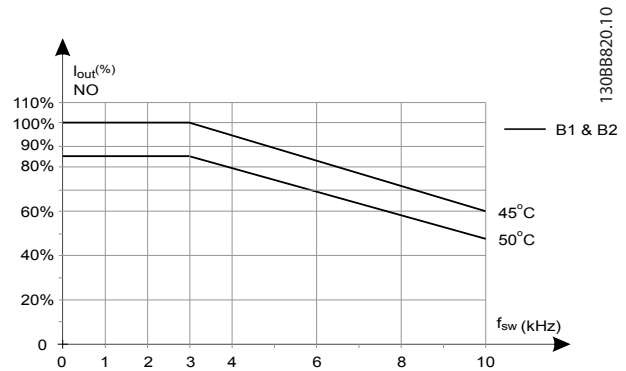


Illustration 5.11 Output Current Derating with Switching Frequency and Ambient Temperature for 600 V Frequency Converters, Enclosure Sizes B, 60 AVM, NO

SFAVM – Stator Frequency Asynchron Vector Modulation

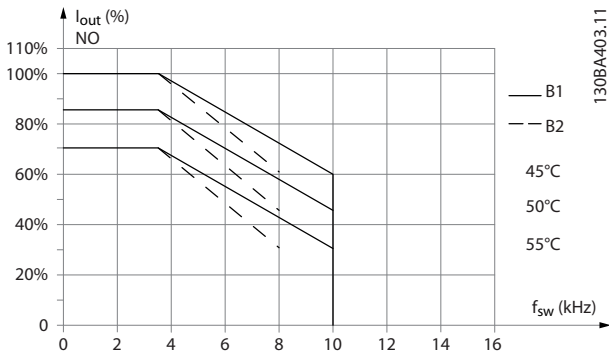


Illustration 5.9 Derating of  $I_{out}$  for different  $T_{AMB, MAX}$  for Enclosure Sizes B1 and B2, using SFAVM in Normal Overload Mode (110% Overtorque)

SFAVM – Stator Frequency Asynchron Vector Modulation

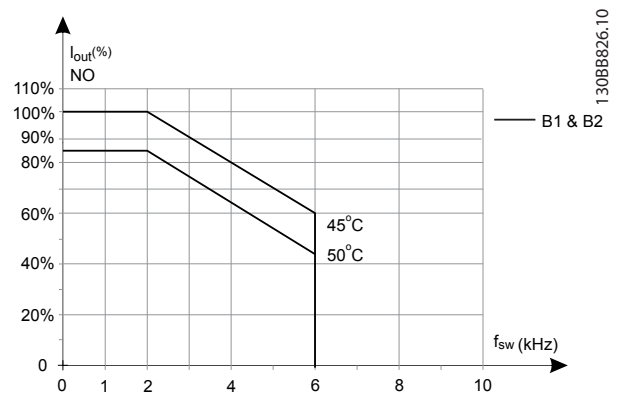


Illustration 5.12 Output Current Derating with Switching Frequency and Ambient Temperature for 600 V Frequency Converters, Enclosure Size B; SFAVM, NO

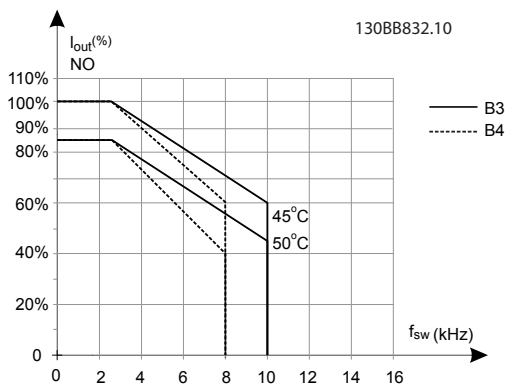
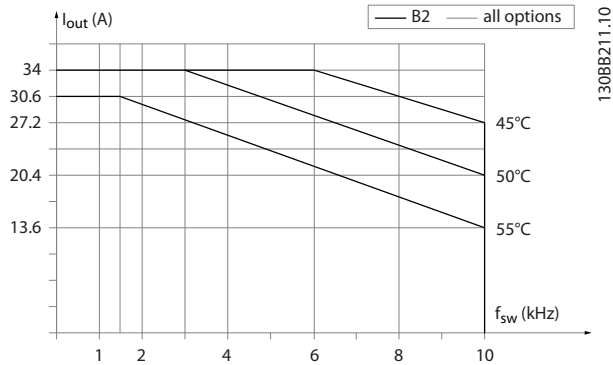


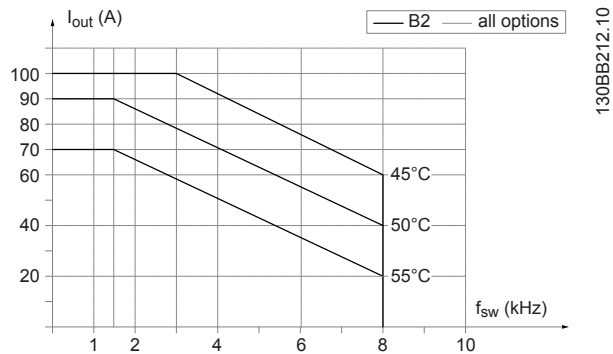
Illustration 5.10 Derating of  $I_{out}$  for different  $T_{AMB, MAX}$  for Enclosure Sizes B3 and B4, using SFAVM in Normal Overload Mode (110% Overtorque)

**Enclosures B, T7**  
**Enclosures B2 and B4, 525-690 V**  
**60° AVM – Pulse Width Modulation**



**Illustration 5.13** Output Current Derating with Switching Frequency and Ambient Temperature for Enclosure Sizes B2 and B4, 60° AVM.

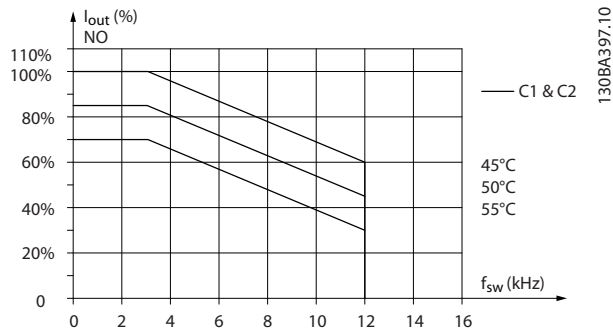
**SFAVM – Stator Frequency Asyncon Vector Modulation**



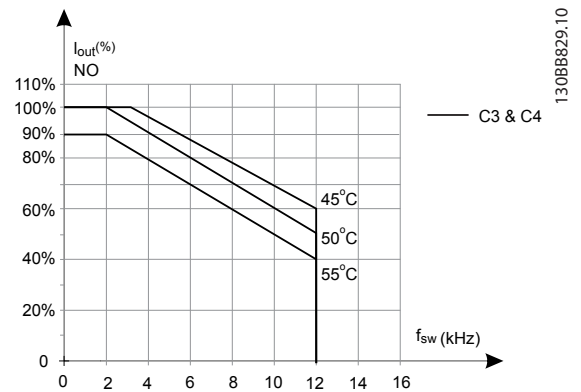
**Illustration 5.14** Output Current Derating with Switching Frequency and Ambient Temperature for Enclosure Sizes B2 and B4, SFAVM.

**5.3.3 Derating for Ambient Temperature, Enclosure Size C**

**Enclosures C, T2, and T4**  
**60° AVM – Pulse Width Modulation**

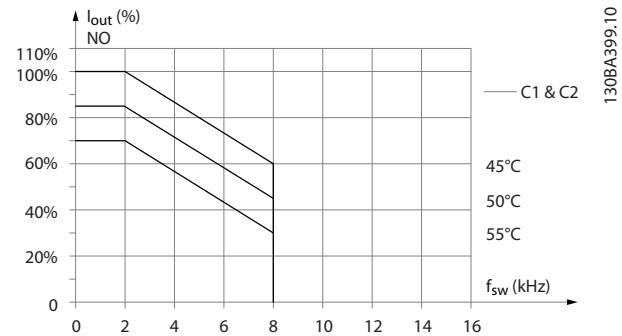


**Illustration 5.15** Derating of  $I_{out}$  for Different  $T_{AMB, MAX}$  for Enclosure Sizes C1 and C2, using 60° AVM in Normal Overload Mode (110% Over Torque)

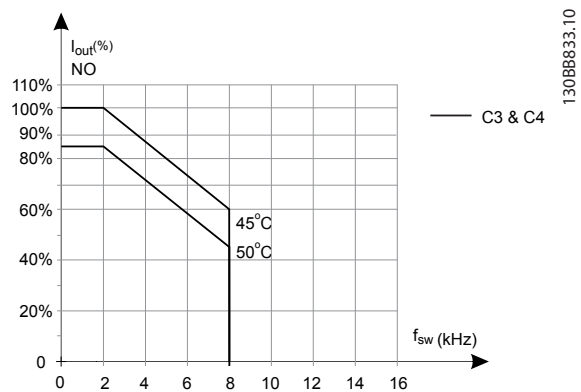


**Illustration 5.16** Derating of  $I_{out}$  for Different  $T_{AMB, MAX}$  for Enclosure Sizes C3 and C4, using 60° AVM in Normal Overload Mode (110% Over Torque)

**SFAVM – Stator Frequency Asyncon Vector Modulation**



**Illustration 5.17** Derating of  $I_{out}$  for Different  $T_{AMB, MAX}$  for Enclosure Sizes C1 and C2, using SFAVM in Normal Overload Mode (110% Over Torque)



**Illustration 5.18** Derating of  $I_{out}$  for Different  $T_{AMB, MAX}$  for Enclosure Sizes C3 and C4, using SFAVM in Normal Overload Mode (110% Over Torque)

5

Enclosure Sizes C, T6

60° AVM – Pulse Width Modulation

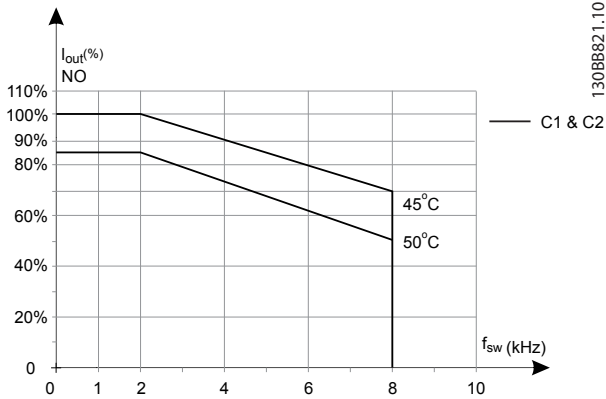


Illustration 5.19 Output Current Derating with Switching Frequency and Ambient Temperature for 600 V Frequency Converters, Enclosure Sizes C, 60° AVM, NO

SFAVM – Stator Frequency Asyncon Vector Modulation

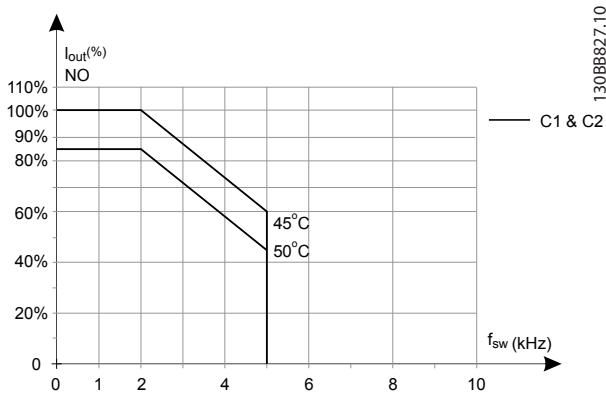


Illustration 5.20 Output Current Derating with Switching Frequency and Ambient Temperature for 600 V Frequency Converters, Enclosure Sizes C; SFAVM, NO

Enclosure Size C, T7

60° AVM – Pulse Width Modulation

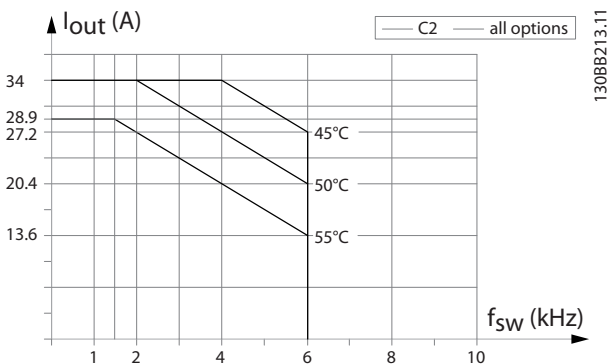


Illustration 5.21 Output Current Derating with Switching Frequency and Ambient Temperature for Enclosure Size C2, 60° AVM.

SFAVM – Stator Frequency Asyncon Vector Modulation

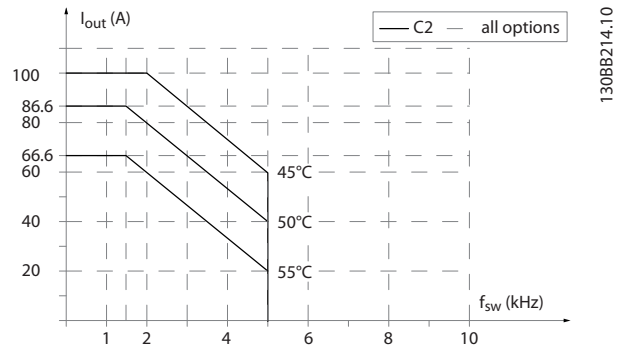


Illustration 5.22 Output Current Derating with Switching Frequency and Ambient Temperature for Enclosure Size C2, SFAVM.

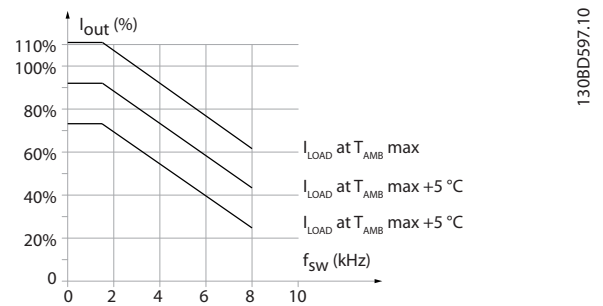


Illustration 5.23 Output Current Derating with Switching Frequency and Ambient Temperature for Enclosure Size C3

## 6 Typecode and Selection

### 6.1 Ordering

1	2	3	4	5	6	7	8	9	10	11	12	13	14	15	16	17	18	19	20	21	22	23	24	25	26	27	28	29	30	31	32	33	34	35	36	37	38	39
F	C	-				P				T										X	X	S	X	X	X	X	A		B		C						D	

130BB836.10

Illustration 6.1 Type Code Example

Configure the right frequency converter for the right application from the internet-based drive configurator and generate the type code string. The drive configurator automatically generates an 8-digit ordering number for delivery to the local sales office.

The Drive Configurator can also establish a project list with several products and send it to a Danfoss sales representative.

Access the drive configurator on the global Internet site: [www.danfoss.com/drives](http://www.danfoss.com/drives).

#### 6.1.1 Type Code

An example of the type code is:

FC-202PK75T4E20H1BGXXXXXXXA0BXCXXXXD0

The meaning of the characters in the string can be found in *Table 6.1* and *Table 6.2*. In the example above, a PROFIBUS DP V1 and a 24 V back-up option are built-in.

Description	Position	Possible choices <sup>1)</sup>
Product group	1-2	FC
Drive series	4-6	202: FC 202
Power rating	8-10	0.25–90 kW
Phases	11	S: Single phase T: Three phases
Mains voltage	12	2: 200–240 V 4: 380–480 V 6: 525–600 V 7: 525–690 V
Enclosure	13-15	E20: IP20 E55: IP 55/NEMA Type 12 P20: IP20 (with back plate) P21: IP21/NEMA Type 1 (with back plate) P55: IP55/NEMA Type 12 (with back plate) Z20: IP 20 <sup>1)</sup> E66: IP 66

Description	Position	Possible choices <sup>1)</sup>
RFI filter	16-17	Hx: No EMC filters built into the frequency converter H1: Integrated EMC filter. Fulfill EN 55011 Class A1/B and EN/IEC 61800-3 Category 1/2 H2: No additional EMC filter. Fulfill EN 55011 Class A2 and EN/IEC 61800-3 Category 3 H3: Integrated EMC filter. Fulfill EN 55011 class A1/B and EN/IEC 61800-3 Category 1/2 H4: Integrated EMC filter. Fulfill EN 55011 class A1 and EN/IEC 61800-3 Category 2 H5: Marine versions. Fulfill same emissions levels as H2 versions
Brake	18	B: Brake chopper included X: No brake chopper included T: Safe torque off No brake <sup>1)</sup> U: Safe torque off brake chopper <sup>1)</sup>
Display	19	G: Graphical local control panel (LCP) N: Numerical local control panel (LCP) X: No local control panel
Coating PCB	20	C: Coated PCB R: Coated PCB + Ruggedised X: No coated PCB
Mains option	21	X: No mains option 1: Mains disconnect 3: Mains disconnect and fuse 5: Mains disconnect, Fuse and load sharing 7: Fuse 8: Mains disconnect and load sharing A: Fuse and load sharing D: Load sharing
Adaptation	22	X: Standard cable entries O: European metric thread in cable entries S: Imperial cable entries
Adaptation	23	X: No adaptation

# 6

Description	Position	Possible choices <sup>1)</sup>
Software release	24-27	SXXX: Latest release – standard software
Software language	28	X: Not used

**Table 6.1 Ordering Type Code**

- 1) Some of the available choices depend on the enclosure size.  
 2) Only available for frequency converters  $\geq 75$  kW.  
 3) Only available for frequency converters  $\geq 355$  kW.

Description	Position	Possible choices
A options	29-30	AX: No A option A0: MCA 101 PROFIBUS DP V1 (standard) A4: MCA 104 DeviceNet (standard) AN: MCA 121 Ethernet IP AL: MCA 120 ProfiNet AQ: MCA 122 Modbus TCP
B options	31-32	BX: No option BY: MCO 101 extended cascade control BK: MCB 101 general purpose I/O option BP: MCB 105 relay option B0: MCB 109 I/O option with RTC back-up B2: MCB 112 PTC thermistor card B4: MCB 114 VLT sensor input
C0 options	33-34	CX: No option
C1 options	35	X: No option R: MCB 113 Ext. relay card 5: MCO 102 Advanced cascade control
C option software	36-37	XX: Standard controller
D options	38-39	DX: No option D0: Extended 24 V DC back-up

**Table 6.2 Ordering Type Code, Options**

### NOTICE

For power sizes over 90 kW, see the *VLT® AQUA Drive FC 202 110-1400 kW Design Guide*.

## 6.1.2 Software Language

The frequency converter is automatically delivered with a software language package relevant to the region from which it is ordered. The regional language packages are listed in *Table 6.3*.

Language package 1			Language package 2
Brazilian Portuguese	Finnish	Russian	Bahasa Indonesian
Bulgarian	French	Spanish	Chinese
Croatian	German	Serbian	Chinese, traditional
Czech	Greek	Slovenian	German
Danish	Hungarian	Spanish	Japanese
Dutch	Italian	Swedish	Korean
English	Polish	Turkish	Russian
English, US	Romanian	-	Thai

**Table 6.3 Software Language Packages**

To order frequency converters with a different language package, contact the local sales office.

## 6.2 Options, Accessories, and Spare Parts

### 6.2.1 Options and Accessories

Description	Ordering no.	
	Uncoated	Coated
<b>Miscellaneous hardware</b>		
VLT® Panel through kit enclosure size A5	130B1028	
VLT® Panel through kit enclosure size B1	130B1046	
VLT® Panel through kit enclosure size B2	130B1047	
VLT® Panel through kit enclosure size C1	130B1048	
VLT® Panel through kit enclosure size C2	130B1049	
VLT® Mounting brackets for enclosure size A5	130B1080	
VLT® Mounting brackets for enclosure size B1	130B1081	
VLT® Mounting brackets for enclosure size B2	130B1082	
VLT® Mounting brackets for enclosure size C1	130B1083	
VLT® Mounting brackets for enclosure size C2	130B1084	
VLT® IP 21/NEMA Type 1 kit, enclosure size A1	130B1121	
VLT® IP 21/NEMA Type 1 kit, enclosure size A2	130B1122	
VLT® IP 21/NEMA Type 1 kit, enclosure size A3	130B1123	
VLT® IP 21/NEMA Type 1 Top kit, enclosure size A2	130B1132	
VLT® IP 21/NEMA Type 1 Top kit, enclosure size A3	130B1133	
VLT® Back plate IP55/NEMA Type12, enclosure size A5	130B1098	
VLT® Back plate IP21/NEMA Type 1, IP55/NEMA Type 12, enclosure size B1	130B3383	
VLT® Back plate IP21/NEMA Type 1, IP55/NEMA Type 12, enclosure size B2	130B3397	
VLT® Back plate IP20/Type 1, enclosure size B4	130B4172	
VLT® Back plate IP21/NEMA Type 1, IP55/NEMA Type 12, enclosure size C1	130B3910	
VLT® Back plate IP21/NEMA Type 1, IP55/NEMA Type 12, enclosure size C2	130B3911	
VLT® Back plate IP20/NEMA Type 1, enclosure size C3	130B4170	
VLT® Back plate IP20/NEMA Type 1, enclosure size C4	130B4171	
VLT® Back plate IP66/NEMA Type 4X, enclosure size A5	130B3242	
VLT® Back plate in stainless steel IP66/NEMA Type 4X, enclosure size B1	130B3434	
VLT® Back plate in stainless steel IP66/NEMA Type 4X, enclosure size B2	130B3465	
VLT® Back plate in stainless steel IP66/NEMA Type 4X, enclosure size C1	130B3468	

Description	Ordering no.	
	Uncoated	Coated
VLT® Back plate in stainless steel IP66/NEMA Type 4X, enclosure size C2	130B3491	
VLT® Profibus adapter Sub-D9 connector	130B1112	
Profibus screen plate kit for IP20, enclosure sizes A1, A2 and A3	130B0524	
Terminal block for DC link connection on enclosure sizes A2/A3	130B1064	
VLT® Screw terminals	130B1116	
VLT® USB extension, 350 mm cable	130B1155	
VLT® USB extension, 650 mm cable	130B1156	
VLT® Back frame A2 for 1 brake resistor	175U0085	
VLT® Back frame A3 for 1 brake resistor	175U0088	
VLT® Back frame A2 for 2 brake resistors	175U0087	
VLT® Back A3 for 2 brake resistors	175U0086	
<b>Local Control Panel</b>		
VLT® LCP 101 Numeric local control pad	130B1124	
VLT® LCP 102 Graphical local control pad	130B1107	
VLT® Cable for LCP 2, 3 m	175Z0929	
VLT® Panel mounting kit for all LCP types	130B1170	
VLT® Panel mounting kit, graphical LCP	130B1113	
VLT® Panel mounting kit, numerical LCP	130B1114	
VLT® LCP mounting kit, no LCP	130B1117	
VLT® LCP mounting kit blind cover IP55/66, 8 m	130B1129	
VLT® Control Panel LCP 102, graphical	130B1078	
VLT® Blindcover, with Danfoss logo, IP55/66	130B1077	
<b>Options for slot A</b>		
VLT® PROFIBUS DP V1 MCA 101	130B1100	130B1200
VLT® DeviceNet MCA 104	130B1102	130B1202
VLT® Profinet MCA 120	130B1135	130B1235
VLT® Ethernet/IP MCA 121	130B1119	130B1219
VLT® Modbus TCP MCA 122	130B1196	130B1296
<b>Options for slot B</b>		
VLT® General purpose I/O MCB 101	130B1125	130B1212
VLT® Relay option MCB 105	130B1110	130B1210
VLT® PTC thermistor card MCB 112		130B1137
VLT® Extended cascade controller MCO 101	130B1118	130B1218
VLT® Sensor input option MCB 114	130B1172	130B1272
VLT® Analog I/O option with RTC MCB 109	130B1143	130B1243
<b>Mounting kits for C options</b>		
VLT® Mounting kit for C option, 40 mm, enclosure sizes A2/A3	130B7530	
VLT® Mounting kit for C option, 60 mm, enclosure sizes A2/A3	130B7531	
VLT® Mounting kit for C option, enclosure size A5	130B7532	
VLT® Mounting kit for C option, enclosure sizes B/C/D/E/F (except B3)	130B7533	
VLT® Mounting kit for C option, 40 mm, enclosure size B3	130B1413	
VLT® Mounting kit for C option, 60 mm, enclosure size B3	130B1414	
<b>Options for slot C</b>		
VLT® Advanced cascade controller MCO102	130B1154	130B1254
VLT® Extended relay card MCB 113	130B1164	130B1264
<b>Option for slot D</b>		
VLT® 24 V DC supply MCB 107	130B1108	130B1208
<b>Leakage current monitor kits</b>		
VLT® Leakage current monitor kit, enclosure sizes A2/A3	130B5645	



Description	Ordering no.	
	Uncoated	Coated
VLT® Leakage current monitor kit, enclosure size B3	130B5764	
VLT® Leakage current monitor kit, enclosure size B4	130B5765	
VLT® Leakage current monitor kit, enclosure size C3	130B6226	
VLT® Leakage current monitor kit, enclosure size C4	130B5647	
<b>PC Software</b>		
MCT 10 Set-up Software, 1 license	130B1000	
MCT 10 Set-up Software, 5 licenses	130B1001	
MCT 10 Set-up Software, 10 licenses	130B1002	
MCT 10 Set-up Software, 25 licenses	130B1003	
MCT 10 Set-up Software, 50 licenses	130B1004	
MCT 10 Set-up Software, 100 licenses	130B1005	
MCT 10 Set-up Software, >100 licenses	130B1006	
Options can be ordered as factory built-in options, see ordering information, <i>chapter 6.1 Ordering</i> .		

Table 6.4 Ordering Numbers for Options and Accessories

### 6.2.2 Spare Parts

Consult the VLT shop or the configurator for spare parts available for your specification, [VLTShop.danfoss.com](http://VLTShop.danfoss.com).

### 6.2.3 Accessory Bags

Type	Description	Ordering no.
<b>Accessory bags</b>		
Accessory bag A1	Accessory bag, enclosure size A1	130B1021
Accessory bag A2/A3	Accessory bag, enclosure size A2/A3	130B1022
Accessory bag A5	Accessory bag, enclosure size A5	130B1023
Accessory bag A1–A5	Accessory bag, enclosure size A1-A5 Brake and load sharing connector	130B0633
Accessory bag B1	Accessory bag, enclosure size B1	130B2060
Accessory bag B2	Accessory bag, enclosure size B2	130B2061
Accessory bag B3	Accessory bag, enclosure size B3	130B0980
Accessory bag B4	Accessory bag, enclosure size B4, 18.5-22 kW	130B1300
Accessory bag B4	Accessory bag, enclosure size B4, 30 kW	130B1301
Accessory bag C1	Accessory bag, enclosure size C1	130B0046
Accessory bag C2	Accessory bag, enclosure size C2	130B0047
Accessory bag C3	Accessory bag, enclosure size C3	130B0981
Accessory bag C4	Accessory bag, enclosure size C4, 55 kW	130B0982
Accessory bag C4	Accessory bag, enclosure size C4, 75 kW	130B0983

Table 6.5 Ordering Numbers for Accessory Bags

## 6.2.4 Brake Resistor Selection

When the speed reference of a frequency converter is reduced, the motor acts as a generator and the frequency converter brakes. When a motor acts as a generator, it supplies energy to the frequency converter which is collected in the DC link. The function of the brake resistor is to provide a load on the DC link during braking, thereby ensuring that the braking power is absorbed by the brake resistor.

If a brake resistor is not used, the DC-link voltage of the frequency converter continues to increase, until disconnecting for protection. The advantage of using a brake resistor is that it enables braking of a heavy load quickly, e.g. on a conveyor belt.

The brake resistors in this series are all external components. Therefore, the brake resistor does not form an integral part of the frequency converter. The external brake resistor provides the following advantages:

- The resistor time cycle can be selected as required.
- The heat developed during braking can be conveyed beyond the panel cabinet to allow the energy to be used.
- The electronic components do not overheat, even when the brake resistor is overloaded.

Recommended brake resistors are listed in *chapter 6.2.5 Recommended Brake Resistors* and *chapter 6.2.6 Alternative Brake Resistors, T2 and T4*. For more information, see the *VLT® Brake Resistor MCE 101 Design Guide*.

### Horizontal and Vertical Loads

The Danfoss brake resistor range consists of 2 groups:

- Brake resistors for horizontal loads (conveyors, trolleys, gantry cranes, etc.), see *Illustration 6.2*;
- Brake resistors for vertical loads (cranes, hoists, elevators), see *Illustration 6.3*.

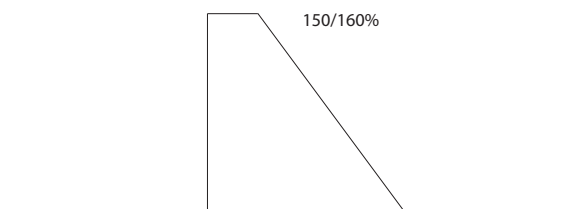


Illustration 6.2 Horizontal Loads

175UA067.10

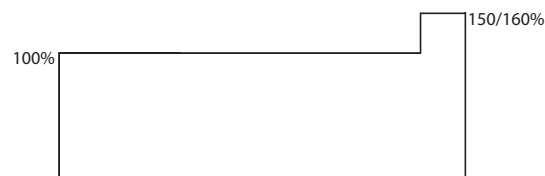


Illustration 6.3 Vertical Loads

175UA068.10

The brake resistor range is intended to cover the general braking requirements for horizontal and vertical brake applications.

To cater for both the horizontal and vertical ranges, 3 types of brake resistors are available:

- Aluminium-housed flat-pack brake resistors
- Aluminium-housed compact brake resistors
- Steel grid brake resistors

See *chapter 6.2.5 Recommended Brake Resistors* and *chapter 6.2.6 Alternative Brake Resistors, T2 and T4* for ordering information.

### 6.2.5 Recommended Brake Resistors

Mains	Voltage class
P <sub>m</sub>	Rated motor size for frequency converter type
R <sub>min</sub>	Minimum permissible brake resistor by frequency converter
R <sub>rec</sub>	Recommended brake resistor resistance of Danfoss brake resistors
Thermo relay	Brake current setting of external thermo relay
Part number	Danfoss brake resistor order numbers
Cable cross section	Recommended minimum value based upon PVC insulated copper cable. 30 °C ambient temperature with normal heat dissipation
P <sub>br,cont.</sub>	Brake resistor average rated power. The temperature switch enables at approximate 90% of continuous rated power at brake resistors with IP54, IP21 and IP65 enclosure protection
R <sub>br,nom</sub>	The nominal (calculated) resistor value to ensure a brake power on motor shaft of 150/160/110% for 1 minute

Table 6.6 Abbreviations used in Table 6.7 to Table 6.14

#### 10% duty cycle, horizontal braking, T2

FC 202				Horizontal braking 10% duty cycle							
Frequency converter data				Brake resistor data						Installation	
				R <sub>rec</sub> [Ω]	P <sub>br,cont.</sub> [kW]	Danfoss part number			Cable cross-section [mm <sup>2</sup> ]	Thermo relay [A]	
Mains type	P <sub>m</sub> [kW]	R <sub>min</sub> [Ω]	R <sub>br,nom</sub> [Ω]			Wire IP54	Screw terminal IP21	Screw terminal IP65			Bolt connection IP20
T2	0.25	380	691.3	630	0.100	175u3002	-	-	-	1.5	0.4
T2	0.37	380	466.7	410	0.100	175u3004	-	-	-	1.5	0.5
T2	0.55	275	313.7	300	0.100	175u3006	-	-	-	1.5	0.6
T2	0.75	188	230.0	200	0.100	175u3011	-	-	-	1.5	0.7
T2	1.1	130	152.9	145	0.100	175u3016	-	-	-	1.5	0.8
T2	1.5	81.0	110.5	100	0.100	175u3021	-	-	-	1.5	0.9
T2	2.2	58.5	74.1	70	0.200	175u3026	-	-	-	1.5	1.6
T2	3	45.0	53.7	48	0.200	175u3031	-	-	-	1.5	1.9
T2	3.7	31.5	39.9	35	0.300	175u3325	-	-	-	1.5	2.7
T2	5.5	22.5	28.7	27	0.360	175u3326	175u3477	175u3478	-	1.5	3.5
T2	7.5	17.7	20.8	18	0.570	175u3327	175u3442	175u3441	-	1.5	5.3
T2	11	12.6	14.0	13	0.680	175u3328	175u3059	175u3060	-	1.5	6.8
T2	15	8.7	10.2	9.0	1.130	175u3329	175u3068	175u3069	-	2.5	10.5
T2	18.5	5.3	8.2	5.7	1.400	175u3330	175u3073	175u3074	-	4	15
T2	22	5.1	6.9	5.7	1.700	175u3331	175u3483	175u3484	-	4	16
T2	30	3.2	5.0	3.5	2.200	175u3332	175u3080	175u3081	-	6	24
T2	37	3.0	4.1	3.5	2.800	175u3333	175u3448	175u3447	-	10	27
T2	45	2.4	3.3	2.8	3.200	175u3334	175u3086	175u3087	-	16	32

Table 6.7 T2, Horizontal Braking 10% Duty Cycle, Recommended Brake Resistors

## 40% duty cycle, vertical braking, T2

FC 202				Vertical braking 40% duty cycle							
Frequency converter data				Brake resistor data						Installation	
				R <sub>rec</sub> [Ω]	P <sub>br,cont.</sub> [kW]	Danfoss part number			Cable cross-section [mm <sup>2</sup> ]	Thermo relay [A]	
Mains type	P <sub>m</sub> [kW]	R <sub>min</sub> [Ω]	R <sub>br,nom</sub> [Ω]			Wire IP54	Screw terminal IP21	Screw terminal IP65			Bolt connection IP20
T2	0.25	380	691.3	630	0.100	175u3002	-	-	-	1.5	0.4
T2	0.37	380	466.7	410	0.100	175u3004	-	-	-	1.5	0.5
T2	0.55	275	313.7	300	0.200	175u3096	-	-	-	1.5	0.8
T2	0.75	188	230.0	200	0.200	175u3008	-	-	-	1.5	0.9
T2	1.1	130	152.9	145	0.300	175u3300	-	-	-	1.5	1.3
T2	1.5	81.0	110.5	100	0.450	175u3301	175u3402	175u3401	-	1.5	2
T2	2.2	58.5	74.1	70	0.570	175u3302	175u3404	175u3403	-	1.5	2.7
T2	3	45.0	53.7	48	0.960	175u3303	175u3406	175u3405	-	1.5	4.2
T2	3.7	31.5	39.9	35	1.130	175u3304	175u3408	175u3407	-	1.5	5.4
T2	5.5	22.5	28.7	27	1.400	175u3305	175u3410	175u3409	-	1.5	6.8
T2	7.5	17.7	20.8	18	2.200	175u3306	175u3412	175u3411	-	1.5	10.4
T2	11	12.6	14.0	13	3.200	175u3307	175u3414	175u3413	-	2.5	14.7
T2	15	8.7	10.2	9.0	5.500	-	175u3176	175u3177	-	4	23
T2	18.5	5.3	8.2	5.7	6.000	-	-	-	175u3233	10	33
T2	22	5.1	6.9	5.7	8.000	-	-	-	175u3234	10	38
T2	30	3.2	5.0	3.5	9.000	-	-	-	175u3235	16	51
T2	37	3.0	4.1	3.5	14.000	-	-	-	175u3224	25	63
T2	45	2.4	3.3	2.8	17.000	-	-	-	175u3227	35	78

Table 6.8 T2, Vertical Braking 40% Duty Cycle, Recommended Brake Resistors

10% duty cycle, horizontal braking, T4

FC 202				Horizontal braking 10% duty cycle							
Frequency converter data				Brake resistor data				Installation			
Mains type	P <sub>m</sub> [kW]	R <sub>min</sub> [Ω]	R <sub>br,nom</sub> [Ω]	R <sub>rec</sub> [Ω]	P <sub>br,cont.</sub> [kW]	Danfoss part number			Cable cross-section [mm <sup>2</sup> ]	Thermo relay [A]	
						Wire IP54	Screw terminal IP21	Screw terminal IP65			Bolt connection IP20
T4	0.37	1000	1864.2	1200	0.100	175u3000	-	-	-	1.5	0.3
T4	0.55	1000	1246.3	1200	0.100	175u3000	-	-	-	1.5	0.3
T4	0.75	620	910.2	850	0.100	175u3001	-	-	-	1.5	0.4
T4	1.1	546	607.3	630	0.100	175u3002	-	-	-	1.5	0.4
T4	1.5	382	437.3	410	0.100	175u3004	-	-	-	1.5	0.5
T4	2.2	260	293.3	270	0.200	175u3007	-	-	-	1.5	0.8
T4	3	189	212.7	200	0.200	175u3008	-	-	-	1.5	0.9
T4	4	135	157.3	145	0.300	175u3300	-	-	-	1.5	1.3
T4	5.5	99.0	113.3	110	0.450	175u3335	175u3450	175u3449	-	1.5	1.9
T4	7.5	72.0	82.4	80	0.570	175u3336	175u3452	175u3451	-	1.5	2.5
T4	11	50.0	55.3	56	0.680	175u3337	175u3027	175u3028	-	1.5	3.3
T4	15	36.0	40.3	38	1.130	175u3338	175u3034	175u3035	-	1.5	5.2
T4	18.5	27.0	32.5	28	1.400	175u3339	175u3039	175u3040	-	1.5	6.7
T4	22	20.3	27.2	22	1.700	175u3340	175u3047	175u3048	-	1.5	8.3
T4	30	18.0	19.8	19	2.200	175u3357	175u3049	175u3050	-	1.5	10.1
T4	37	13.4	16.0	14	2.800	175u3341	175u3055	175u3056	-	2.5	13.3
T4	45	10.8	13.1	12	3.200	175u3359	175u3061	175u3062	-	2.5	15.3
T4	55	8.8	10.7	9.5	4.200	-	175u3065	175u3066	-	4	20
T4	75	6.5	7.8	7.0	5.500	-	175u3070	175u3071	-	6	26
T4	90	4.2	6.5	5.5	7.000	-	-	-	175u3231	10	36
T4	110	3.6	5.3	4.7	9.000	-	-	-	175u3079	16	44
T4	132	3.0	4.4	3.7	11.000	-	-	-	175u3083	25	55
T4	160	2.5	3.6	3.3	13.000	-	-	-	175u3084	35	63
T4	200	2.0	2.9	2.7	16.000	-	-	-	175u3088	50	77
T4	250	1.6	2.3	2.1	20.000	-	-	-	175u3091	70	98
T4	315	1.2	1.8	1.7	26.000	-	-	-	175u3093	2 x 35	124
T4	355	1.2	1.6	1.3	32.000	-	-	-	175u3097	2 x 35	157
T4	400	1.2	1.4	1.2	36.000	-	-	-	175u3098	2 x 50	173
T4	450	1.1	1.3	1.1	42.000	-	-	-	175u3099	2 x 50	196
T4	500	0.9	1.1	2 x 1.9	-	-	-	-	-	-	-
T4	560	0.9	1.0	2 x 1.7	-	-	-	-	-	-	-
T4	630	0.8	0.9	2 x 1.5	-	-	-	-	-	-	-
T4	710	0.7	0.8	2 x 1.3	-	-	-	-	-	-	-
T4	800	0.6	0.7	3 x 1.8	-	-	-	-	-	-	-
T4	1000	0.5	0.6	3 x 1.6	-	-	-	-	-	-	-

Table 6.9 T4, Horizontal Braking 10% Duty Cycle, Recommended Brake Resistors

## 40% duty cycle, vertical braking, T4

FC 202				Vertical braking 40% duty cycle							
Frequency converter data				Brake resistor data				Installation			
Mains type	P <sub>m</sub> [kW]	R <sub>min</sub> [Ω]	R <sub>br,nom</sub> [Ω]	R <sub>rec</sub> [Ω]	P <sub>br,cont.</sub> [kW]	Danfoss part number				Cable cross-section [mm <sup>2</sup> ]	Thermo relay [A]
						Wire IP54	Screw terminal IP21	Screw terminal IP65	Bolt connection IP20		
T4	0.37	1000	1864.2	1200	0.200	175u3101	-	-	-	1.5	0.4
T4	0.55	1000	1246.3	1200	0.200	175u3101	-	-	-	1.5	0.4
T4	0.75	620	910.2	850	0.200	175u3308	-	-	-	1.5	0.5
T4	1.1	546	607.3	630	0.300	175u3309	-	-	-	1.5	0.7
T4	1.5	382	437.3	410	0.450	175u3310	175u3416	175u3415	-	1.5	1
T4	2.2	260	293.3	270	0.570	175u3311	175u3418	175u3417	-	1.5	1.4
T4	3	189	212.7	200	0.960	175u3312	175u3420	175u3419	-	1.5	2.1
T4	4	135	157.3	145	1.130	175u3313	175u3422	175u3421	-	1.5	2.7
T4	5.5	99.0	113.3	110	1.700	175u3314	175u3424	175u3423	-	1.5	3.7
T4	7.5	72.0	82.4	80	2.200	175u3315	175u3138	175u3139	-	1.5	5
T4	11	50.0	55.3	56	3.200	175u3316	175u3428	175u3427	-	1.5	7.1
T4	15	36.0	40.3	38	5.000	-	-	-	175u3236	1.5	11.5
T4	18.5	27.0	32.5	28	6.000	-	-	-	175u3237	2.5	14.7
T4	22	20.3	27.2	22	8.000	-	-	-	175u3238	4	19
T4	30	18.0	19.8	19	10.000	-	-	-	175u3203	4	23
T4	37	13.4	16.0	14	14.000	-	-	-	175u3206	10	32
T4	45	10.8	13.1	12	17.000	-	-	-	175u3210	10	38
T4	55	8.8	10.7	9.5	21.000	-	-	-	175u3213	16	47
T4	75	6.5	7.8	7.0	26.000	-	-	-	175u3216	25	61
T4	90	4.2	6.5	5.5	36.000	-	-	-	175u3219	35	81
T4	110	3.6	5.3	4.7	42.000	-	-	-	175u3221	50	95
T4	132	3.0	4.4	3.7	52.000	-	-	-	175u3223	70	119
T4	160	2.5	3.6	3.3	60.000	-	-	-	175u3225	2 x 35	135
T4	200	2.0	2.9	2.7	78.000	-	-	-	175u3228	2 x 50	170
T4	250	1.6	2.3	2.1	90.000	-	-	-	175u3230	2 x 70	207
T4	315	1.2	1.8	1.7	-	-	-	-	-	-	-
T4	355	1.2	1.6	1.3	-	-	-	-	-	-	-
T4	400	1.2	1.4	1.2	-	-	-	-	-	-	-
T4	450	1.1	1.3	1.1	-	-	-	-	-	-	-
T4	500	0.9	1.1	2 x 1.9	-	-	-	-	-	-	-
T4	560	0.9	1.0	2 x 1.7	-	-	-	-	-	-	-
T4	630	0.8	0.9	2 x 1.5	-	-	-	-	-	-	-
T4	710	0.7	0.8	2 x 1.3	-	-	-	-	-	-	-
T4	800	0.6	0.7	3 x 1.8	-	-	-	-	-	-	-
T4	1000	0.5	0.6	3 x 1.6	-	-	-	-	-	-	-

Table 6.10 T4, Vertical Braking 40% Duty Cycle, Recommended Brake Resistors

10% duty cycle, horizontal braking, T6

FC 202				Horizontal braking 10% duty cycle							
Frequency converter data				Brake resistor data						Installation	
				R <sub>rec</sub> [Ω]	P <sub>br,cont.</sub> [kW]	Danfoss part number				Cable cross-section [mm <sup>2</sup> ]	Thermo relay [A]
Mains type	P <sub>m</sub> [kW]	R <sub>min</sub> [Ω]	R <sub>br,nom</sub> [Ω]			Wire IP54	Screw terminal IP21	Screw terminal IP65	Bolt connection IP20		
T6	0.75	620	1329.7	1200	0.100	175u3000	-	-	-	1.5	0.3
T6	1.1	620	889.1	850	0.100	175u3001	-	-	-	1.5	0.4
T6	1.5	550	642.7	570	0.100	175u3003	-	-	-	1.5	0.4
T6	2.2	380	431.1	415	0.200	175u3005	-	-	-	1.5	0.7
T6	3	260	312.5	270	0.200	175u3007	-	-	-	1.5	0.8
T6	4	189	231.6	200	0.300	175u3342	-	-	-	1.5	1.1
T6	5.5	135	166.6	145	0.450	175u3343	175u3012	175u3013	-	1.5	1.7
T6	7.5	99.0	121.1	100	0.570	175u3344	175u3136	175u3137	-	1.5	2.3
T6	11	69.0	81.6	72	0.680	175u3345	175u3456	175u3455	-	1.5	2.9
T6	15	48.6	59.4	52	1.130	175u3346	175u3458	175u3457	-	1.5	4.4
T6	18.5	35.1	47.9	38	1.400	175u3347	175u3460	175u3459	-	1.5	5.7
T6	22	27.0	40.1	31	1.700	175u3348	175u3037	175u3038	-	1.5	7
T6	30	22.5	29.2	27	2.200	175u3349	175u3043	175u3044	-	1.5	8.5
T6	37	17.1	23.6	19	2.800	175u3350	175u3462	175u3461	-	2.5	11.4
T6	45	13.5	19.4	14	3.200	175u3358	175u3464	175u3463	-	2.5	14.2
T6	55	11.7	15.8	13.5	4.200	-	175u3057	175u3058	-	4	17
T6	75	9.9	11.5	11	5.500	-	175u3063	175u3064	-	6	21
T6	90	8.6	9.6	7.0	7.000	-	-	-	175u3245	10	32

Table 6.11 T6, Horizontal Braking 10% Duty Cycle, Recommended Brake Resistors

40% duty cycle, vertical braking, T6

FC 202				Vertical braking 40% duty cycle							
Frequency converter data				Brake resistor data						Installation	
				R <sub>rec</sub> [Ω]	P <sub>br,cont.</sub> [kW]	Danfoss part number				Cable cross-section [mm <sup>2</sup> ]	Thermo relay [A]
Mains type	P <sub>m</sub> [kW]	R <sub>min</sub> [Ω]	R <sub>br,nom</sub> [Ω]			Wire IP54	Screw terminal IP21	Screw terminal IP65	Bolt connection IP20		
T6	0.75	620	1329.7	1200	0.360	-	175u3102	175u3103	-	1.5	0.6
T6	1.1	620	889.1	850	0.280	175u3317	175u3104	175u3105	-	1.5	0.6
T6	1.5	550	642.7	570	0.450	175u3318	175u3430	175u3429	-	1.5	0.9
T6	2.2	380	431.1	415	0.570	175u3319	175u3432	175u3431	-	1.5	1.1
T6	3	260	312.5	270	0.960	175u3320	175u3434	175u3433	-	1.5	1.8
T6	4	189	231.6	200	1.130	175u3321	175u3436	175u3435	-	1.5	2.3
T6	5.5	135	166.6	145	1.700	175u3322	175u3126	175u3127	-	1.5	3.3
T6	7.5	99.0	121.1	100	2.200	175u3323	175u3438	175u3437	-	1.5	4.4
T6	11	69.0	81.6	72	3.200	175u3324	175u3440	175u3439	-	1.5	6.3
T6	15	48.6	59.4	52	5.500	-	175u3148	175u3149	-	1.5	9.7
T6	18.5	35.1	47.9	38	6.000	-	-	-	175u3239	2.5	12.6
T6	22	27.0	40.1	31	8.000	-	-	-	175u3240	4	16
T6	30	22.5	29.2	27	10.000	-	-	-	175u3200	4	19
T6	37	17.1	23.6	19	14.000	-	-	-	175u3204	10	27
T6	45	13.5	19.4	14	17.000	-	-	-	175u3207	10	35
T6	55	11.7	15.8	13.5	21.000	-	-	-	175u3208	16	40
T6	75	9.9	11.5	11	26.000	-	-	-	175u3211	25	49
T6	90	8.6	9.6	7.0	30.000	-	-	-	175u3241	35	66

Table 6.12 T6, Vertical Braking 40% Duty Cycle, Recommended Brake Resistors

## 10% duty cycle, horizontal braking, T7

FC 202				Horizontal braking 10% duty cycle							
Frequency converter data				Brake resistor data						Installation	
				R <sub>rec</sub> [Ω]	P <sub>br,cont.</sub> [kW]	Danfoss part number			Cable cross-section [mm <sup>2</sup> ]	Thermo relay [A]	
Mains type	P <sub>m</sub> [kW]	R <sub>min</sub> [Ω]	R <sub>br,nom</sub> [Ω]			Wire IP54	Screw terminal IP21	Screw terminal IP65			Bolt connection IP20
T7	1.1	620	830	630	0.100	175u3002	-	-	-	1.5	0.4
T7	1.5	513	600	570	0.100	175u3003	-	-	-	1.5	0.4
T7	2.2	340	403	415	0.200	175u3005	-	-	-	1.5	0.7
T7	3	243	292	270	0.300	175u3361	-	-	-	1.5	1
T7	4	180	216	200	0.360	-	175u3009	175u3010	-	1.5	1.3
T7	5.5	130	156	145	0.450	-	175u3012	175u3013	-	1.5	1.7
T7	7.5	94	113	105	0.790	-	175u3481	175u3482	-	1.5	2.6
T7	11	94.5	110.9	105	0.790	175u3360	175u3481	175u3482	-	1.5	2.7
T7	15	69.7	80.7	72	1.130	175u3351	175u3466	175u3465	-	1.5	3.8
T7	18.5	46.8	65.1	52	1.400	175u3352	175u3468	175u3467	-	1.5	4.9
T7	22	36.0	54.5	42	1.700	175u3353	175u3032	175u3033	-	1.5	6
T7	30	29.0	39.7	31	2.200	175u3354	175u3470	175u3469	-	1.5	7.9
T7	37	22.5	32.1	27	2.800	175u3355	175u3472	175u3471	-	2.5	9.6
T7	45	18.0	26.3	22	3.200	175u3356	175u3479	175u3480	-	2.5	11.3
T7	55	13.5	21.4	15.5	4.200	-	175u3474	175u3473	-	4	15
T7	75	13.5	15.6	13.5	5.500	-	175u3476	175u3475	-	6	19
T7	90	8.8	13.0	11	7.000	-	-	-	175u3232	10	25
T7	110	8.8	10.6	9.1	9.000	-	-	-	175u3067	16	32
T7	132	6.6	8.8	7.4	11.000	-	-	-	175u3072	16	39
T7	160	4.2	7.2	6.1	13.000	-	-	-	175u3075	16	46
T7	200	4.2	5.8	5.0	16.000	-	-	-	175u3078	25	57
T7	250	3.4	4.6	4.0	20.000	-	-	-	175u3082	35	71
T7	315	2.3	3.7	3.2	26.000	-	-	-	175u3085	50	90
T7	400	2.3	2.9	2.5	32.000	-	-	-	175u3089	70	113
T7	450	2.0	2.6	2.3	36.000	-	-	-	175u3090	2 x 35	125
T7	500	1.9	2.3	2.0	42.000	-	-	-	175u3092	2 x 35	145
T7	560	1.5	2.1	1.6	52.000	-	-	-	175u3094	2 x 50	180
T7	630	1.4	1.8	1.4	60.000	-	-	-	175u3095	2 x 50	207
T7	710	1.2	1.6	2 x 2.6	-	-	-	-	-	-	-
T7	800	1.1	1.4	2 x 2.2	-	-	-	-	-	-	-
T7	900	1.0	1.3	2 x 2.0	-	-	-	-	-	-	-
T7	1000	0.9	1.1	3 x 2.6	-	-	-	-	-	-	-
T7	1200	0.8	1.0	3 x 2.4	-	-	-	-	-	-	-
T7	1400	0.6	0.8	3 x 2.0	-	-	-	-	-	-	-

Table 6.13 T7, Horizontal Braking 10% Duty Cycle, Recommended Brake Resistors



40% duty cycle, vertical braking, T7

FC 202				Vertical braking 40% duty cycle							
Frequency converter data				Brake resistor data				Installation			
				R <sub>rec</sub> [Ω]	P <sub>br,cont.</sub> [kW]	Danfoss part number			Cable cross-section [mm <sup>2</sup> ]	Thermo relay [A]	
Mains type	P <sub>m</sub> [kW]	R <sub>min</sub> [Ω]	R <sub>br,nom</sub> [Ω]			Wire IP54	Screw terminal IP21	Screw terminal IP65			Bolt connection IP20
T7	1.1	620	830	630	0.360	-	175u3108	175u3109	-	1.5	0.8
T7	1.5	513	600	570	0.570	-	175u3110	175u3111	-	1.5	1
T7	2.2	340	403	415	0.790	-	175u3112	175u3113	-	1.5	1.3
T7	3	243	292	270	1.130	-	175u3118	175u3119	-	1.5	2
T7	4	180	216	200	1.700	-	175u3122	175u3123	-	1.5	2.8
T7	5.5	130	156	145	2.200	-	175u3106	175u3107	-	1.5	3.7
T7	7.5	94	113	105	3.200	-	175u3132	175u3133	-	1.5	5.2
T7	11	94.5	110.9	105	4.200	-	175u3134	175u3135	-	1.5	6
T7	15	69.7	80.7	72	4.200	-	175u3142	175u3143	-	1.5	7.2
T7	18.5	46.8	65.1	52	6.000	-	-	-	175u3242	2.5	10.8
T7	22	36.0	54.5	42	8.000	-	-	-	175u3243	2.5	13.9
T7	30	29.0	39.7	31	10.000	-	-	-	175u3244	4	18
T7	37	22.5	32.1	27	14.000	-	-	-	175u3201	10	23
T7	45	18.0	26.3	22	17.000	-	-	-	175u3202	10	28
T7	55	13.5	21.4	15.5	21.000	-	-	-	175u3205	16	37
T7	75	13.5	15.6	13.5	26.000	-	-	-	175u3209	16	44
T7	90	8.8	13.0	11	36.000	-	-	-	175u3212	25	57
T7	110	8.8	10.6	9.1	42.000	-	-	-	175u3214	35	68
T7	132	6.6	8.8	7.4	52.000	-	-	-	175u3215	50	84
T7	160	4.2	7.2	6.1	60.000	-	-	-	175u3218	70	99
T7	200	4.2	5.8	5.0	78.000	-	-	-	175u3220	2 x 35	125
T7	250	3.4	4.6	4.0	90.000	-	-	-	175u3222	2 x 35	150
T7	315	2.3	3.7	3.2	-	-	-	-	-	-	-
T7	400	2.3	2.9	2.5	-	-	-	-	-	-	-
T7	450	2.0	2.6	2.3	-	-	-	-	-	-	-
T7	500	1.9	2.3	2.0	-	-	-	-	-	-	-
T7	560	1.5	2.1	1.6	-	-	-	-	-	-	-
T7	630	1.4	1.8	1.4	-	-	-	-	-	-	-
T7	710	1.2	1.6	2 x 2.6	-	-	-	-	-	-	-
T7	800	1.1	1.4	2 x 2.2	-	-	-	-	-	-	-
T7	900	1.0	1.3	2 x 2.0	-	-	-	-	-	-	-
T7	1000	0.9	1.1	3 x 2.6	-	-	-	-	-	-	-
T7	1200	0.8	1.0	3 x 2.4	-	-	-	-	-	-	-
T7	1400	0.6	0.8	3 x 2.0	-	-	-	-	-	-	-

Table 6.14 T7, Vertical Braking 40% Duty Cycle, Recommended Brake Resistors

## 6.2.6 Alternative Brake Resistors, T2 and T4

Mains	Voltage class
$P_m$	Rated motor size for frequency converter type
$R_{min}$	Minimum permissible brake resistor - by frequency converter
$R_{rec}$	Recommended brake resistor resistance of Danfoss brake resistors
Duty cycle	$P_{br,cont} \times 100 / P_m$
Part number	Danfoss brake resistor order numbers
$P_{br,cont}$	Brake resistor average rated power.
$R_{br,nom}$	The nominal (calculated) resistor value to ensure a brake power on motor shaft of 150/160/110% for 1 minute

Table 6.15 Abbreviations used in Table 6.16 to Table 6.17

### Mains: 200-240 V, T2

FC 202	$P_m$	$R_{min}$	$R_{br,nom}$	Flat-pack IP65		
				$R_{rec}$ per item/ $P_{br,cont}$	Duty cycle	Danfoss part number
T2	[kW]	[ $\Omega$ ]	[ $\Omega$ ]	[ $\Omega/W$ ]	%	175Uxxxx
PK25	0.25	380	691.3	430/100	40	1002
PK37	0.37	380	466.7	430/100	27	1002
PK55	0.55	275	313.7	330/100	18	1003
PK55	0.55	275	313.7	310/200	36	0984
PK75	0.75	188	230.0	220/100	13	1004
PK75	0.75	188	230.0	210/200	26	0987
P1K1	1.1	130	152.9	150/100	9	1005
P1K1	1.1	130	152.9	150/200	18	0989
P1K5	1.5	81.0	110.5	100/100	7	1006
P1K5	1.5	81.0	110.5	100/200	14	0991
P2K2	2.2	58.5	74.1	72/200	9	0992
P3K0	3	45.0	53.7	50/200	7	0993
P3K7	3.7	31.5	39.9	35/200	6	0994
P3K7	3.7	31.5	39.9	72/200	11	2 x 0992
P5K5	5.5	22.5	28.7	40/200	7	2 x 0996

Table 6.16 Mains: 200-240 V (T2), Alternative Brake Resistors

### Mains: 380-480 V, T4

FC 202	$P_m$	$R_{min}$	$R_{br,nom}$	Flat-pack IP65		
				$R_{rec}$ per item/ $P_{br,cont}$	Duty cycle	Danfoss part number
T4	[kW]	[ $\Omega$ ]	[ $\Omega$ ]	[ $\Omega/W$ ]	%	175Uxxxx
PK75	0.75	620	910.2	830/100	13	1000
P1K1	1.1	546	607.3	620/100	9	1001
P1K1	1.1	546	607.3	620/200	18	0982
P1K5	1.5	382	437.3	430/100	7	1002
P1K5	1.5	382	437.3	430/200	14	0983
P2K2	2.2	260	293.3	310/200	9	0984
P3K0	3	189	212.7	210/200	7	0987
P4K0	4	135	157.3	150/200	5	0989
P4K0	4	135	157.3	300/200	10	2 x 0985
P5K5	5.5	99.0	113.3	130/200	7	2 x 0990
P7K5	7.5	72.0	82.4	80/240	6	2 x 0090

Table 6.17 Mains: 380-480 V (T4), Alternative Brake Resistors

### 6.2.7 Harmonic Filters

Harmonic filters are used to reduce mains harmonics.

- AHF 010: 10% current distortion
- AHF 005: 5% current distortion

#### Cooling and ventilation

IP20: Cooled by natural convection or with built-in fans.

IP00: Additional forced cooling is required. Secure sufficient airflow through the filter during installation to prevent overheating of the filter. Airflow of minimum 2 m/s is required through the filter.

Power and current ratings <sup>1)</sup>		Typical motor	Filter current rating		Ordering number AHF 005		Ordering number AHF 010	
[kW]	[A]		50 Hz		IP00	IP20	IP00	IP20
0.37-4.0	1.2-9	3	10	130B1392	130B1229	130B1262	130B1027	
5.5-7.5	14.4	7.5	14	130B1393	130B1231	130B1263	130B1058	
11.0	22	11	22	130B1394	130B1232	130B1268	130B1059	
15.0	29	15	29	130B1395	130B1233	130B1270	130B1089	
18.0	34	18.5	34	130B1396	130B1238	130B1273	130B1094	
22.0	40	22	40	130B1397	130B1239	130B1274	130B1111	
30.0	55	30	55	130B1398	130B1240	130B1275	130B1176	
37.0	66	37	66	130B1399	130B1241	130B1281	130B1180	
45.0	82	45	82	130B1442	130B1247	130B1291	130B1201	
55.0	96	55	96	130B1443	130B1248	130B1292	130B1204	
75.0	133	75	133	130B1444	130B1249	130B1293	130B1207	
90.0	171	90	171	130B1445	130B1250	130B1294	130B1213	

6

Table 6.18 Harmonic Filters for 380-415 V, 50 Hz

Power and current ratings <sup>1)</sup>		Typical motor	Filter current rating		Ordering number AHF 005		Ordering number AHF 010	
[kW]	[A]		60 Hz		IP00	IP20	IP00	IP20
0.37-4.0	1.2-9	3	10	130B3095	130B2857	130B2874	130B2262	
5.5-7.5	14.4	7.5	14	130B3096	130B2858	130B2875	130B2265	
11.0	22	11	22	130B3097	130B2859	130B2876	130B2268	
15.0	29	15	29	130B3098	130B2860	130B2877	130B2294	
18.0	34	18.5	34	130B3099	130B2861	130B3000	130B2297	
22.0	40	22	40	130B3124	130B2862	130B3083	130B2303	
30.0	55	30	55	130B3125	130B2863	130B3084	130B2445	
37.0	66	37	66	130B3026	130B2864	130B3085	130B2459	
45.0	82	45	82	130B3127	130B2865	130B3086	130B2488	
55.0	96	55	96	130B3128	130B2866	130B3087	130B2489	
75.0	133	75	133	130B3129	130B2867	130B3088	130B2498	
90.0	171	90	171	130B3130	130B2868	130B3089	130B2499	

Table 6.19 Harmonic Filters for 380-415 V, 60 Hz

Power and current ratings <sup>1)</sup>		Typical motor	Filter current rating		Ordering number AHF 005		Ordering number AHF 010	
			60 Hz		IP00	IP20	IP00	IP20
[kW]	[A]	[kW]	[A]					
0.37–4.0	1–7.4	3	10	130B1787	130B1752	130B1770	130B1482	
5.5–7.5	9.9–13	7.5	14	130B1788	130B1753	130B1771	130B1483	
11.0	19	11	19	130B1789	130B1754	130B1772	130B1484	
15.0	25	15	25	130B1790	130B1755	130B1773	130B1485	
18.0	31	18.5	31	130B1791	130B1756	130B1774	130B1486	
22.0	36	22	36	130B1792	130B1757	130B1775	130B1487	
30.0	47	30	48	130B1793	130B1758	130B1776	130B1488	
37.0	59	37	60	130B1794	130B1759	130B1777	130B1491	
45.0	73	45	73	130B1795	130B1760	130B1778	130B1492	
55.0	95	55	95	130B1796	130B1761	130B1779	130B1493	
75.0	118	75	118	130B1797	130B1762	130B1780	130B1494	
90	154	90	154	130B1798	130B1763	130B1781	130B1495	

Table 6.20 Harmonic Filters for 440-480 V, 60 Hz

1) Frequency converter power and current ratings according to actual operating conditions

Power and current ratings <sup>1)</sup>		Typical motor	Filter current rating		Ordering number AHF 005		Ordering number AHF 010	
			60 Hz		IP00	IP20	IP00	IP20
[kW]	[A]	[kW]	[A]					
11.0	15	10	15	130B5261	130B5246	130B5229	130B5212	
15.0	19	16.4	20	130B5262	130B5247	130B5230	130B5213	
18.0	24	20	24	130B5263	130B5248	130B5231	130B5214	
22.0	29	24	29	130B5263	130B5248	130B5231	130B5214	
30.0	36	33	36	130B5265	130B5250	130B5233	130B5216	
37.0	49	40	50	130B5266	130B5251	130B5234	130B5217	
45.0	58	50	58	130B5267	130B5252	130B5235	130B5218	
55.0	74	60	77	130B5268	130B5253	130B5236	130B5219	
75.0	85	75	87	130B5269	130B5254	130B5237	130B5220	
90	106	90	109	130B5270	130B5255	130B5238	130B5221	

Table 6.21 Harmonic Filters for 600 V, 60 Hz

Power and current ratings <sup>1)</sup>		Typical motor	Power and Current Ratings		Typical motor	Filter current rating	Ordering number AHF 005		Ordering number AHF 010	
			551-690 V				50 Hz		IP00	IP20
500-550 V										
[kW]	[A]	[kW]	[kW]	[A]	[kW]	[A]	IP00	IP20	IP00	IP20
11.0	15	7.5	P15K	16	15	15	130B5000	130B5088	130B5297	130B5280
15.0	19.5	11	P18K	20	18.5	20	130B5017	130B5089	130B5298	130B5281
18.0	24	15	P22K	25	22	24	130B5018	130B5090	130B5299	130B5282
22.0	29	18.5	P30K	31	30	29	130B5019	130B5092	130B5302	130B5283
30.0	36	22	P37K	38	37	36	130B5021	130B5125	130B5404	130B5284
37.0	49	30	P45K	48	45	50	130B5022	130B5144	130B5310	130B5285
45.0	59	37	P55K	57	55	58	130B5023	130B5168	130B5324	130B5286
55.0	71	45	P75K	76	75	77	130B5024	130B5169	130B5325	130B5287
75.0	89	55				87	130B5025	130B5170	130B5326	130B5288
90.0	110	90				109	130B5026	130B5172	130B5327	130B5289

Table 6.22 Harmonic Filters for 500-690 V, 50 Hz

1) Frequency converter power and current ratings according to actual operating conditions

## 6.2.8 Sine-Wave Filters

Frequency converter power and current ratings						Filter current rating			Switching frequency	Ordering number	
200-240 V		380-440 V		441-500 V		50 Hz	60 Hz	100 Hz		IP00	IP20/23 <sup>1)</sup>
[kW]	[A]	[kW]	[A]	[kW]	[A]	[A]	[A]	[A]	[kHz]		
-	-	0.37	1.3	0.37	1.1	2.5	2.5	2	5	130B2404	130B2439
0.25	1.8	0.55	1.8	0.55	1.6						
0.37	2.4	0.75	2.4	0.75	2.1						
		1.1	3	1.1	3	4.5	4	3.5	5	130B2406	130B2441
0.55	3.5	1.5	4.1	1.5	3.4						
0.75	4.6	2.2	5.6	2.2	4.8	8	7.5	5.5	5	130B2408	130B2443
1.1	6.6	3	7.2	3	6.3						
1.5	7.5	-	-	-	-						
-	-	4	10	4	8.2	10	9.5	7.5	5	130B2409	130B2444
2.2	10.6	5.5	13	5.5	11	17	16	13	5	130B2411	130B2446
3	12.5	7.5	16	7.5	14.5						
3.7	16.7	-	-	-	-						
5.5	24.2	11	24	11	21	24	23	18	4	130B2412	130B2447
7.5	30.8	15	32	15	27	38	36	28.5	4	130B2413	130B2448
		18.5	37.5	18.5	34						
11	46.2	22	44	22	40	48	45.5	36	4	130B2281	130B2307
15	59.4	30	61	30	52	62	59	46.5	3	130B2282	130B2308
18.5	74.8	37	73	37	65	75	71	56	3	130B2283	130B2309
22	88	45	90	55	80	115	109	86	3	130B3179	130B3181*
30	115	55	106	75	105						
37	143	75	147	90	130	180	170	135	3	130B3182	130B3183*
45	170	90	177								

Table 6.23 Sine-wave Filters for Frequency Converters with 380-500 V

1) Ordering numbers marked with \* are IP23.

Frequency converter power and current ratings						Filter current rating @690 V			Switching frequency	Ordering number	
525–600 V		551–690 V		525–550 V		50 Hz	60 Hz	100 Hz		IP00	IP20/23 <sup>1)</sup>
[kW]	[A]	[kW]	[A]	[kW]	[A]	[A]	[A]	[A]	kHz		
0.75	1.7	1.1	1.6	1.1	2.1	4.5	4	3	4	130B7335	130B7356
1.1	2.4	1.5	2.2	1.5	2.7						
1.5	2.7	2.2	3.2	2.2	3.9						
2.2	3.9	3.0	4.5	3.0	4.9						
3	4.9	4.0	5.5	4.0	6.1	10	9	7	4	130B7289	130B7324
4	6.1	5.5	7.5	5.5	9.0						
5.5	9	7.5	10	7.5	11						
7.5	11	11	13	7.5	14	13	12	9	3	130B3195	130B3196
11	18	15	18	11	19	28	26	21	3	130B4112	130B4113
15	22	18.5	22	15	23						
18.5	27	22	27	18	28						
22	34	30	34	22	36	45	42	33	3	130B4114	130B4115
30	41	37	41	30	48						
37	52	45	52	37	54	76	72	57	3	130B4116	130B4117*
45	62	55	62	45	65						
55	83	75	83	55	87	115	109	86	3	130B4118	130B4119*
75	100	90	100	75	105						
90	131	-	-	90	137	165	156	124	2	130B4121	130B4124*

Table 6.24 Sine-wave Filters for Frequency Converters with 525–600 V and 525–690 V

1) Ordering numbers marked with \* are IP23.

Parameter	Setting
14-00 Switching Pattern	[1] SFAVM
14-01 Switching Frequency	Set according the individual filter. Listed at filter product label and in output filter manual. Sine-wave filters do not allow lower switching frequency than specified by the individual filter.
14-55 Output Filter	[2] Sine-wave filter fixed

Table 6.25 Parameter Settings for Sine-wave Filter Operation

### 6.2.9 dU/dt Filters

Frequency converter ratings [V]										Filter current rating [V]				Ordering number		
200-240		380-440		441-500		525-550		551-690		380 @60 Hz 200-400/ 440@50 Hz	460/480 @60 Hz 500/525 @50 Hz	575/600 @60 Hz	690 @50 Hz	IP00	IP20	IP54
[kW]	[A]	[kW]	[A]	[kW]	[A]	[kW]	[A]	[kW]	[A]	[A]	[A]	[A]	[A]			
3	12.5	5.5	13	5.5	11	5.5	9.5	1.1	1.6	17	15	13	10	N/A	130B7367 <sup>1)</sup>	N/A
3.7	16	7.5	16	7.5	14.5	7.5	11.5	1.5	2.2							
-	-	-	-	-	-	-	-	2.2	3.2							
-	-	-	-	-	-	-	-	3	4.5							
-	-	-	-	-	-	-	-	4	5.5							
-	-	-	-	-	-	-	-	5.5	7.5							
-	-	-	-	-	-	-	-	7.5	10							
5.5	24.2	11	24	11	21	7,5	14	11	13	44	40	32	27	130B2835	130B2836*	130B2837
7.5	30.8	15	32	15	27	11	19	15	18							
-	-	18.5	37.5	18.5	34	15	23	18.5	22							
-	-	22	44	22	40	18,5	28	22	27							
11	46.2	30	61	30	52	30	43	30	34	90	80	58	54	130B2838	130B2839*	130B2840
15	59.4	37	73	37	65	37	54	37	41							
18.5	74.8	45	90	55	80	45	65	45	52							
22	88	-	-	-	-	-	-	-	-							
-	-	55	106	75	105	55	87	55	62	106	105	94	86	130B2841	130B2842*	130B2843
-	-	-	-	-	-	-	-	75	83							
30	115	75	147	90	130	75	113	90	108	177	160	131	108	130B2844	130B2845*	130B2846
37	143	90	177	-	-	90	137	-	-							
45	170	-	-	-	-	-	-	-	-							

6

Table 6.26 dU/dt Filters for 200-690 V

1) Dedicated A3 enclosure sizes supporting foot print mounting and book style mounting. Fixed screened cable connection to frequency converter.

Parameter	Setting
14-01 Switching Frequency	Higher operating switching frequency than specified by the individual filter is not recommended.
14-55 Output Filter	[0] No filter
14-56 Capacitance Output Filter	Not used
14-57 Inductance Output Filter	Not used

Table 6.27 Parameter Settings for dU/dt Filter Operation

6.2.10 Common Mode Filters

Enclosure size	Order number	Core dimension					Weight [kg]
		W	w	H	h	d	
A and B	130B3257	60	43	40	25	22.3	0.25
C1	130B7679	82.8	57.5	45.5	20.6	33	
C2, C3, C4	130B3258	102	69	61	28	37	1.6
D	130B3259	189	143	126	80	37	2.45

Table 6.28 Common Mode Filters, Ordering Numbers

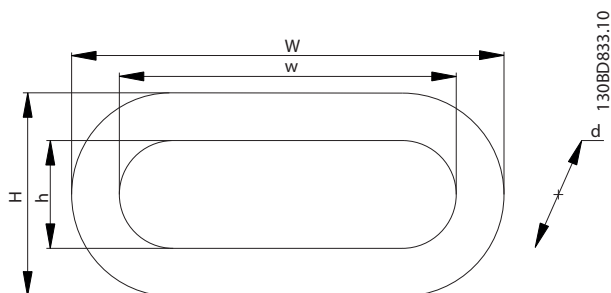


Illustration 6.4 HF-CM Core

6



## 7 Specifications

### 7.1 Electrical Data

#### 7.1.1 Mains Supply 1x200–240 V AC

Type designation	P1K1	P1K5	P2K2	P3K0	P3K7	P5K5	P7K5	P15K	P22K
Typical shaft output [kW]	1.1	1.5	2.2	3.0	3.7	5.5	7.5	15	22
Typical shaft output at 240 V [hp]	1.5	2.0	2.9	4.0	4.9	7.5	10	20	30
Protection rating IP20/Chassis	A3	-	-	-	-	-	-	-	-
Protection rating IP21/Type 1	-	B1	B1	B1	B1	B1	B2	C1	C2
Protection rating IP55/Type 12	A5	B1	B1	B1	B1	B1	B2	C1	C2
Protection rating IP66/NEMA 4X	A5	B1	B1	B1	B1	B1	B2	C1	C2
<b>Output current</b>									
Continuous (3x200–240 V) [A]	6.6	7.5	10.6	12.5	16.7	24.2	30.8	59.4	88
Intermittent (3x200–240 V) [A]	7.3	8.3	11.7	13.8	18.4	26.6	33.4	65.3	96.8
Continuous kVA at 208 V [kVA]	2.4	2.7	3.8	4.5	6.0	8.7	11.1	21.4	31.7
<b>Maximum input current</b>									
Continuous (1x200–240 V) [A]	12.5	15	20.5	24	32	46	59	111	172
Intermittent (1x200–240 V) [A]	13.8	16.5	22.6	26.4	35.2	50.6	64.9	122.1	189.2
Maximum pre-fuses [A]	20	30	40	40	60	80	100	150	200
<b>Additional specifications</b>									
Maximum cable cross-section (mains, motor, brake) [mm <sup>2</sup> ] ([AWG])	0.2-4 (4-10)					10 (7)	35 (2)	50 (1/0)	95 (4/0)
Maximum cable cross-section <sup>2)</sup> for mains with disconnect switch [mm <sup>2</sup> ] ([AWG])	16 (6)	16 (6)	16 (6)	16 (6)	16 (6)	16 (6)	25 (3)	50 (1/0)	2 x 50 (2 x 1/0) <sup>9)</sup> 10)
Maximum cable cross-section <sup>2)</sup> for mains without disconnect switch [mm <sup>2</sup> ] ([AWG])	16 (6)	16 (6)	16 (6)	16 (6)	16 (6)	16 (6)	25 (3)	50 (1/0)	95 (4/0)
Cable insulation temperature rating [°C]	75	75	75	75	75	75	75	75	75
Estimated power loss <sup>3)</sup> at rated maximum load [W] <sup>4)</sup>	44	30	44	60	74	110	150	300	440
Efficiency <sup>5)</sup>	0.98	0.98	0.98	0.98	0.98	0.98	0.98	0.98	0.98

Table 7.1 Mains Supply 1x200–240 V AC, Normal Overload 110% for 1 Minute, P1K1–P22K

**7.1.2 Mains Supply 3x200–240 V AC**

Type designation	PK25		PK37		PK55		PK75	
	HO	NO	HO	NO	HO	NO	HO	NO
High/normal overload <sup>1)</sup>								
Typical shaft output [kW]	0.25		0.37		0.55		0.75	
Typical shaft output at 208 V [hp]	0.34		0.5		0.75		1	
Protection rating IP20/Chassis <sup>6)</sup> Protection rating IP21/Type 1	A2		A2		A2		A2	
Protection rating IP55/Type 12 Protection rating IP66/NEMA 4X	A4/A5		A4/A5		A4/A5		A4/A5	
<b>Output current</b>								
Continuous (3x200–240 V) [A]	1.8		2.4		3.5		4.6	
Intermittent (3x200–240 V) [A]	2.7	2.0	3.6	2.6	5.3	3.9	6.9	5.1
Continuous kVA at 208 V [kVA]	0.65		0.86		1.26		1.66	
<b>Maximum input current</b>								
Continuous (3x200–240 V) [A]	1.6		2.2		3.2		4.1	
Intermittent (3x200–240 V) [A]	2.4	1.8	3.3	2.4	4.8	3.5	6.2	4.5
Maximum pre-fuses [A]	10		10		10		10	
<b>Additional specifications</b>								
Maximum cable cross-section <sup>2)</sup> for mains, motor, brake, and load sharing [mm <sup>2</sup> ] (AWG)	4, 4, 4 (12, 12, 12) (minimum 0.2 (24))							
Maximum cable cross-section <sup>2)</sup> for mains disconnect [mm <sup>2</sup> ] (AWG)	6, 4, 4 (10, 12, 12)							
Estimated power loss <sup>3)</sup> at rated maximum load [W] <sup>4)</sup>	21		29		42		54	
Efficiency <sup>5)</sup>	0.94		0.94		0.95		0.95	

**Table 7.2 Mains Supply 3x200–240 V AC, PK25–PK75**

Type designation	P1K1		P1K5		P2K2		P3K0		P3K7	
	HO	NO	HO	NO	HO	NO	HO	NO	HO	NO
High/normal overload <sup>1)</sup>										
Typical shaft output [kW]	1.1		1.5		2.2		3.0		3.7	
Typical shaft output at 208 V [hp]	1.5		2		3		4		5	
Protection rating IP20/Chassis <sup>6)</sup> Protection rating IP21/Type 1	A2		A2		A2		A3		A3	
Protection rating IP55/Type 12 Protection rating IP66/NEMA 4X	A4/A5		A4/A5		A4/A5		A5		A5	
<b>Output current</b>										
Continuous (3x200–240 V) [A]	6.6		7.5		10.6		12.5		16.7	
Intermittent (3x200–240 V) [A]	9.9	7.3	11.3	8.3	15.9	11.7	18.8	13.8	25	18.4
Continuous kVA at 208 V [kVA]	2.38		2.70		3.82		4.50		6.00	
<b>Maximum input current</b>										
Continuous (3x200–240 V) [A]	5.9		6.8		9.5		11.3		15.0	
Intermittent (3x200–240 V) [A]	8.9	6.5	10.2	7.5	14.3	10.5	17.0	12.4	22.5	16.5
Maximum pre-fuses [A]	20		20		20		32		32	
<b>Additional specifications</b>										
Maximum cable cross-section <sup>2)</sup> for mains, motor, brake, and load sharing [mm <sup>2</sup> ] (AWG)	4, 4, 4 (12, 12, 12) (minimum 0.2 (24))									
Maximum cable cross-section <sup>2)</sup> for mains disconnect [mm <sup>2</sup> ] (AWG)	6, 4, 4 (10, 12, 12)									
Estimated power loss <sup>3)</sup> at rated maximum load [W] <sup>4)</sup>	63		82		116		155		185	
Efficiency <sup>5)</sup>	0.96		0.96		0.96		0.96		0.96	

**Table 7.3 Mains Supply 3x200–240 V AC, P1K1–P3K7**

Type designation	P5K5		P7K5		P11K		P15K	
High/normal overload <sup>1)</sup>	HO	NO	HO	NO	HO	NO	HO	NO
Typical shaft output [kW]	3.7	5.5	5.5	7.5	7.5	11	11	15
Typical shaft output at 208 V [hp]	5.0	7.5	7.5	10	10	15	15	20
IP20/Chassis <sup>7)</sup>	B3		B3		B3		B4	
Protection rating IP21/Type 1	B1		B1		B1		B2	
Protection rating IP55/Type 12								
Protection rating IP66/NEMA 4X								
<b>Output current</b>								
Continuous (3x200–240 V) [A]	16.7	24.2	24.2	30.8	30.8	46.2	46.2	59.4
Intermittent (3x200–240 V) [A]	26.7	26.6	38.7	33.9	49.3	50.8	73.9	65.3
Continuous kVA at 208 V [kVA]	6.0	8.7	8.7	11.1	11.1	16.6	16.6	21.4
<b>Maximum input current</b>								
Continuous (3x200–240 V) [A]	15.0	22.0	22.0	28.0	28.0	42.0	42.0	54.0
Intermittent (3x200–240 V) [A]	24.0	24.2	35.2	30.8	44.8	46.2	67.2	59.4
Maximum pre-fuses [A]	63		63		63		80	
<b>Additional specifications</b>								
IP20 maximum cable cross-section <sup>2)</sup> for mains, brake, motor, and load sharing [mm <sup>2</sup> ] ([AWG])	10, 10, - (8, 8, -)		10, 10, - (8, 8, -)		10, 10, - (8, 8, -)		35, -, - (2, -, -)	
Protection rating IP21 maximum cable cross-section <sup>2)</sup> for mains, brake, and load sharing [mm <sup>2</sup> ] ([AWG])	16, 10, 16 (6, 8, 6)		16, 10, 16 (6, 8, 6)		16, 10, 16 (6, 8, 6)		35, -, - (2, -, -)	
Protection rating IP21 maximum cable cross-section <sup>2)</sup> for motor [mm <sup>2</sup> ] ([AWG])	10, 10, - (8, 8, -)		10, 10, - (8, 8, -)		10, 10, - (8, 8, -)		35, 25, 25 (2, 4, 4)	
Maximum cable cross-section <sup>2)</sup> for mains disconnect [mm <sup>2</sup> ] ([AWG])	16, 10, 10 (6, 8, 8)						35 (2)	
Estimated power loss <sup>3)</sup> at rated maximum load [W] <sup>4)</sup>	239	310	239	310	371	514	463	602
Efficiency <sup>5)</sup>	0.96		0.96		0.96		0.96	

7

**Table 7.4 Mains Supply 3x200–240 V AC, P5K5–P15K**

Type designation	P18K		P22K		P30K		P37K		P45K	
High/normal overload <sup>1)</sup>	HO	NO	HO	NO	HO	NO	HO	NO	HO	NO
Typical shaft output [kW]	15	18.5	18.5	22	22	30	30	37	37	45
Typical shaft output at 208 V [hp]	20	25	25	30	30	40	40	50	50	60
Protection rating IP20/Chassis <sup>7)</sup>	B4		C3		C3		C4		C4	
Protection rating IP21/Type 1										
Protection rating IP55/Type 12	C1		C1		C1		C2		C2	
Protection rating IP66/NEMA 4X										
<b>Output current</b>										
Continuous (3x200–240 V) [A]	59.4	74.8	74.8	88.0	88.0	115	115	143	143	170
Intermittent (3x200–240 V) [A]	89.1	82.3	112	96.8	132	127	173	157	215	187
Continuous kVA at 208 V [kVA]	21.4	26.9	26.9	31.7	31.7	41.4	41.4	51.5	51.5	61.2
<b>Maximum input current</b>										
Continuous (3x200–240 V) [A]	54.0	68.0	68.0	80.0	80.0	104	104	130	130	154.0
Intermittent (3x200–240 V) [A]	81.0	74.8	102	88.0	120	114	156	143	195	169.0
Maximum pre-fuses [A]	125		125		160		200		250	
<b>Additional specifications</b>										
Protection rating IP20 maximum cable cross-section for mains, brake, motor, and load sharing [mm <sup>2</sup> ] ([AWG])	35 (2)		50 (1)		50 (1)		150 (300 MCM)		150 (300 MCM)	
Protection ratings IP21, IP55, IP66 maximum cable cross-section for mains and motor [mm <sup>2</sup> ] ([AWG])	50 (1)		50 (1)		50 (1)		150 (300 MCM)		150 (300 MCM)	
Protection ratings IP21, IP55, IP66 maximum cable cross-section for brake, and load sharing [mm <sup>2</sup> ] ([AWG])	50 (1)		50 (1)		50 (1)		95 (3/0)		95 (3/0)	
Maximum cable cross-section <sup>2)</sup> for disconnect [mm <sup>2</sup> ] ([AWG])			50, 35, 35 (1, 2, 2)				95, 70, 70 (3/0, 2/0, 2/0)		185, 150, 120 (350 MCM, 300 MCM, 4/0)	
Estimated power loss <sup>3)</sup> at rated maximum load [W] <sup>4)</sup>	624	737	740	845	874	1140	1143	1353	1400	1636
Efficiency <sup>5)</sup>	0.96		0.97		0.97		0.97		0.97	

**Table 7.5 Mains Supply 3x200–240 V AC, P18K–P45K**

### 7.1.3 Mains Supply 1x380–480 V AC

Type designation	P7K5	P11K	P18K	P37K
Typical shaft output [kW]	7.5	11	18.5	37
Typical shaft output at 240 V [hp]	10	15	25	50
Protection rating IP21/Type 1	B1	B2	C1	C2
Protection rating IP55/Type 12	B1	B2	C1	C2
Protection rating IP66/NEMA 4X	B1	B2	C1	C2
<b>Output current</b>				
Continuous (3x380–440 V) [A]	16	24	37.5	73
Intermittent (3x380–440 V) [A]	17.6	26.4	41.2	80.3
Continuous (3x441–480 V) [A]	14.5	21	34	65
Intermittent (3x441–480 V) [A]	15.4	23.1	37.4	71.5
Continuous kVA at 400 V [kVA]	11.0	16.6	26	50.6
Continuous kVA at 460 V [kVA]	11.6	16.7	27.1	51.8
<b>Maximum input current</b>				
Continuous (1x380–440 V) [A]	33	48	78	151
Intermittent (1x380–440 V) [A]	36	53	85.5	166

Continuous (1x441–480 V) [A]	30	41	72	135
Intermittent (1x441–480 V) [A]	33	46	79.2	148
Maximum pre-fuses [A]	63	80	160	250
<b>Additional specifications</b>				
Maximum cable cross-section for mains, motor, and brake [mm <sup>2</sup> ] ([AWG])	10 (7)	35 (2)	50 (1/0)	120 (4/0)
Estimated power loss <sup>3)</sup> at rated maximum load [W] <sup>4</sup>	300	440	740	1480
Efficiency <sup>5)</sup>	0.96	0.96	0.96	0.96

**Table 7.6 Mains Supply 1x380–480 V AC, Normal Overload 110% for 1 Minute, P7K5–P37K**

### 7.1.4 Mains Supply 3x380–480 V AC

Type designation	PK37		PK55		PK75		P1K1		P1K5	
	HO	NO	HO	NO	HO	NO	HO	NO	HO	NO
High/normal overload <sup>1)</sup>										
Typical shaft output [kW]	0.37		0.55		0.75		1.1		1.5	
Typical shaft output at 460 V [hp]	0.5		0.75		1.0		1.5		2.0	
Protection rating IP20/Chassis <sup>6)</sup>	A2		A2		A2		A2		A2	
Protection rating IP55/Type 12	A4/A5		A4/A5		A4/A5		A4/A5		A4/A5	
Protection rating IP66/NEMA 4X	A4/A5		A4/A5		A4/A5		A4/A5		A4/A5	
<b>Output current</b>										
Continuous (3x380–440 V) [A]	1.3		1.8		2.4		3.0		4.1	
Intermittent (3x380–440 V) [A]	2.0	1.4	2.7	2.0	3.6	2.6	4.5	3.3	6.2	4.5
Continuous (3x441–480 V) [A]	1.2		1.6		2.1		2.7		3.4	
Intermittent (3x441–480 V) [A]	1.8	1.3	2.4	1.8	3.2	2.3	4.1	3.0	5.1	3.7
Continuous kVA at 400 V [kVA]	0.9		1.3		1.7		2.1		2.8	
Continuous kVA at 460 V [kVA]	0.9		1.3		1.7		2.4		2.7	
<b>Maximum input current</b>										
Continuous (3x380–440 V) [A]	1.2		1.6		2.2		2.7		3.7	
Intermittent (3x380–440 V) [A]	1.8	1.3	2.4	1.8	3.3	2.4	4.1	3.0	5.6	4.1
Continuous (3x441–480 V) [A]	1.0		1.4		1.9		2.7		3.1	
Intermittent (3x441–480 V) [A]	1.5	1.1	2.1	1.5	2.9	2.1	4.1	3.0	4.7	3.4
Maximum pre-fuses [A]	10		10		10		10		10	
<b>Additional specifications</b>										
Protection ratings IP20, IP21 maximum cable cross-section <sup>2)</sup> for mains, motor, brake, and load sharing [mm <sup>2</sup> ] ([AWG])	4, 4, 4 (12, 12, 12) (minimum 0.2 (24))									
Protection ratings IP55, IP66 maximum cable cross-section <sup>2)</sup> for mains, motor, brake, and load sharing [mm <sup>2</sup> ] ([AWG])	4, 4, 4 (12, 12, 12)									
Maximum cable cross-section <sup>2)</sup> for disconnect [mm <sup>2</sup> ] ([AWG])	6, 4, 4 (10, 12, 12)									
Estimated power loss <sup>3)</sup> at rated maximum load [W] <sup>4</sup>	35		42		46		58		62	
Efficiency <sup>5)</sup>	0.93		0.95		0.96		0.96		0.97	

**Table 7.7 Mains Supply 3x380–480 V AC, PK37–P1K5**

Type designation	P2K2		P3K0		P4K0		P5K5		P7K5	
	HO	NO	HO	NO	HO	NO	HO	NO	HO	NO
High/normal overload <sup>1)</sup>										
Typical shaft output [kW]	2.2		3.0		4.0		5.5		7.5	
Typical shaft output at 460 V [hp]	2.9		4.0		5.3		7.5		10	
Protection rating IP20/Chassis <sup>6)</sup>	A2		A2		A2		A3		A3	
Protection rating IP55/Type 12	A4/A5		A4/A5		A4/A5		A5		A5	
Protection rating IP66/NEMA 4X	A4/A5		A4/A5		A4/A5		A5		A5	
<b>Output current</b>										
Continuous (3x380–440 V) [A]	5.6		7.2		10		13		16	
Intermittent (3x380–440 V) [A]	8.4	6.2	10.8	7.9	15.0	11.0	19.5	14.3	24.0	17.6
Continuous (3x441–480 V) [A]	4.8		6.3		8.2		11		14.5	
Intermittent (3x441–480 V) [A]	7.2	5.3	9.5	6.9	12.3	9.0	16.5	12.1	21.8	16.0
Continuous kVA at 400 V [kVA]	3.9		5.0		6.9		9.0		11.0	
Continuous kVA at 460 V [kVA]	3.8		5.0		6.5		8.8		11.6	
<b>Maximum input current</b>										
Continuous (3x380–440 V) [A]	5.0		6.5		9.0		11.7		14.4	
Intermittent (3x380–440 V) [A]	7.5	5.5	9.8	7.2	13.5	9.9	17.6	12.9	21.6	15.8
Continuous (3x441–480 V) [A]	4.3		5.7		7.4		9.9		13.0	
Intermittent (3x441–480 V) [A]	6.5	4.7	8.6	6.3	11.1	8.1	14.9	10.9	19.5	14.3
Maximum pre-fuses [A]	20		20		20		30		30	
<b>Additional specifications</b>										
Protection ratings IP20, IP21 maximum cable cross-section <sup>2)</sup> for mains, motor, brake, and load sharing [mm <sup>2</sup> ] ([AWG])	4, 4, 4 (12, 12, 12) (minimum 0.2 (24))									
Protection ratings IP55, IP66 maximum cable cross-section <sup>2)</sup> for mains, motor, brake, and load sharing [mm <sup>2</sup> ] ([AWG])	4, 4, 4 (12, 12, 12)									
Maximum cable cross-section <sup>2)</sup> for disconnect [mm <sup>2</sup> ] ([AWG])	6, 4, 4 (10, 12, 12)									
Estimated power loss <sup>3)</sup> at rated maximum load [W] <sup>4)</sup>	88		116		124		187		225	
Efficiency <sup>5)</sup>	0.97		0.97		0.97		0.97		0.97	

**Table 7.8 Mains Supply 3x380–480 V AC, P2K2–P7K5**

Type designation	P11K		P15K		P18K		P22K		P30K	
High/normal overload <sup>1)</sup>	HO	NO	HO	NO	HO	NO	HO	NO	HO	NO
Typical shaft output [kW]	7.5	11	11	15	15	18.5	22.0	22.0	22.0	30
Typical shaft output at 460 V [hp]	10	15	15	20	20	25	30	30	30	40
Protection rating IP20/Chassis <sup>7)</sup>	B3		B3		B3		B4			B4
Protection rating IP21/Type 1	B1		B1		B1		B2		B2	
Protection rating IP55/Type 12	B1		B1		B1		B2		B2	
Protection rating IP66/NEMA 4X	B1		B1		B1		B2		B2	
<b>Output current</b>										
Continuous (3x380–440 V) [A]	-	24	24	32	32	37.5	37.5	44	44	61
Intermittent (60 s overload) (3x380–440 V) [A]	-	26.4	38.4	35.2	51.2	41.3	60	48.4	70.4	67.1
Continuous (3x441–480 V) [A]	-	21	21	27	27	34	34	40	40	52
Intermittent (60 s overload) (3x441–480 V) [A]	-	23.1	33.6	29.7	43.2	37.4	54.4	44	64	61.6
Continuous kVA at 400 V [kVA]	-	16.6	16.6	22.2	22.2	26	26	30.5	30.5	42.3
Continuous kVA at 460 V [kVA]	-	16.7	16.7	21.5	21.5	27.1	27.1	31.9	31.9	41.4
<b>Maximum input current</b>										
Continuous (3x380–440 V) [A]	-	22	22	29	29	34	34	40	40	55
Intermittent (60 s overload) (3x380–440 V) [A]	-	24.2	35.2	31.9	46.4	37.4	54.4	44	64	60.5
Continuous (3x441–480 V) [A]	-	19	19	25	25	31	31	36	36	47
Intermittent (60 s overload) (3x441–480 V) [A]	-	20.9	30.4	27.5	40	34.1	49.6	39.6	57.6	51.7
Maximum pre-fuses [A]	-	63		63		63		63		80
<b>Additional specifications</b>										
Protection ratings IP21, IP55, IP66 maximum cable cross-section <sup>2)</sup> for mains, brake, and load sharing [mm <sup>2</sup> ] ([AWG])	16, 10, 16 (6, 8, 6)						35, -, - (2, -, -)			
Protection ratings IP21, IP55, IP66 maximum cable cross-section <sup>2)</sup> for motor [mm <sup>2</sup> ] ([AWG])	10, 10,- (8, 8,-)						35, 25, 25 (2, 4, 4)			
Protection rating IP20 maximum cable cross-section <sup>2)</sup> for mains, brake, motor, and load sharing [mm <sup>2</sup> ] ([AWG])	10, 10,- (8, 8,-)						35, -, - (2, -, -)			
Maximum cable cross-section <sup>2)</sup> for disconnect [mm <sup>2</sup> ] ([AWG])	16, 10, 10 (6, 8, 8)									
Estimated power loss <sup>3)</sup> at rated maximum load [W] <sup>4)</sup>	291	392	291	392	379	465	444	525	547	739
Efficiency <sup>5)</sup>	0.98		0.98		0.98		0.98		0.98	

7

**Table 7.9 Mains Supply 3x380–480 V AC, P11K–P30K**

Type designation	P37K		P45K		P55K		P75K		P90K	
High/normal overload <sup>1)</sup>	HO	NO	HO	NO	HO	NO	HO	NO	HO	NO
Typical shaft output [kW]	30	37	37	45	45	55	55	75	75	90
Typical shaft output at 460 V [hp]	40	50	50	60	60	75	75	100	100	125
Protection rating IP20/Chassis <sup>6)</sup>	B4		C3		C3		C4		C4	
Protection rating IP21/Type 1	C1		C1		C1		C2		C2	
Protection rating IP55/Type 12	C1		C1		C1		C2		C2	
Protection rating IP66/NEMA 4X	C1		C1		C1		C2		C2	
<b>Output current</b>										
Continuous (3x380–440 V) [A]	61	73	73	90	90	106	106	147	147	177
Intermittent (60 s overload) (3x380–440 V) [A]	91.5	80.3	110	99	135	117	159	162	221	195
Continuous (3x441–480 V) [A]	52	65	65	80	80	105	105	130	130	160
Intermittent (60 s overload) (3x441–480 V) [A]	78	71.5	97.5	88	120	116	158	143	195	176
Continuous kVA at 400 V [kVA]	42.3	50.6	50.6	62.4	62.4	73.4	73.4	102	102	123
Continuous kVA at 460 V [kVA]	41.4	51.8	51.8	63.7	63.7	83.7	83.7	104	103.6	128
<b>Maximum input current</b>										
Continuous (3x380–440 V) [A]	55	66	66	82	82	96	96	133	133	161
Intermittent (60 s overload) (3x380–440 V) [A]	82.5	72.6	99	90.2	123	106	144	146	200	177
Continuous (3x441–480 V) [A]	47	59	59	73	73	95	95	118	118	145
Intermittent (60 s overload) (3x441–480 V) [A]	70.5	64.9	88.5	80.3	110	105	143	130	177	160
Maximum pre-fuses [A]	100		125		160		250		250	
<b>Additional specifications</b>										
Protection rating IP20 maximum cable cross-section for mains and motor [mm <sup>2</sup> ] ([AWG])	35 (2)		50 (1)		50 (1)		150 (300 MCM)		150 (300 MCM)	
Protection rating IP20 maximum cable cross-section for brake and load sharing [mm <sup>2</sup> ] ([AWG])	35 (2)		50 (1)		50 (1)		95 (4/0)		95 (4/0)	
Protection ratings IP21, IP55, IP66 maximum cable cross-section for mains and motor [mm <sup>2</sup> ] ([AWG])	50 (1)		50 (1)		50 (1)		150 (300 MCM)		150 (300 MCM)	
Protection ratings IP21, IP55, IP66 maximum cable cross-section for brake and load sharing [mm <sup>2</sup> ] ([AWG])	50 (1)		50 (1)		50 (1)		95 (3/0)		95 (3/0)	
Maximum cable cross-section <sup>2)</sup> for mains disconnect [mm <sup>2</sup> ] ([AWG])			50, 35, 35 (1, 2, 2)				95, 70, 70 (3/0, 2/0, 2/0)		185, 150, 120 (350 MCM, 300 MCM, 4/0)	
Estimated power loss <sup>3)</sup> at rated maximum load [W] <sup>4)</sup>	570	698	697	843	891	1083	1022	1384	1232	1474
Efficiency <sup>5)</sup>	0.98		0.98		0.98		0.98		0.99	

**Table 7.10 Mains Supply 3x380–480 V AC, P37K–P90K**



### 7.1.5 Mains Supply 3x525–600 V AC

Type designation	PK75		P1K1		P1K5		P2K2	
	HO	NO	HO	NO	HO	NO	HO	NO
High/normal overload <sup>1)</sup>								
Typical shaft output [kW]	0.75		1.1		1.5		2.2	
Typical shaft output [hp]	1		1.5		2		3	
Protection rating IP20/Chassis	A3		A3		A3		A3	
Protection rating IP21/Type 1	A3		A3		A3		A3	
Protection rating IP55/Type 12	A5		A5		A5		A5	
<b>Output current</b>								
Continuous (3x525–550 V) [A]	1.8		2.6		2.9		4.1	
Intermittent (3x525–550 V) [A]	2.7	2.0	3.9	2.9	4.4	3.2	6.2	4.5
Continuous (3x551–600 V) [A]	1.7		2.4		2.7		3.9	
Intermittent (3x551–600 V) [A]	2.6	1.9	3.6	2.6	4.1	3.0	5.9	4.3
Continuous kVA at 550 V [kVA]	1.7		2.5		2.8		3.9	
Continuous kVA at 550 V [kVA]	1.7		2.4		2.7		3.9	
<b>Maximum input current</b>								
Continuous (3x525–600 V) [A]	1.7		2.4		2.7		4.1	
Intermittent (3x525–600 V) [A]	2.6	1.9	3.6	2.6	4.1	3.0	6.2	4.5
Maximum pre-fuses [A]	10		10		10		20	
<b>Additional specifications</b>								
Maximum cable cross-section <sup>2)</sup> for mains, motor, brake, and load sharing [mm <sup>2</sup> ] ([AWG])	4,4,4 (12,12,12) (minimum 0.2 (24))							
Maximum cable cross-section <sup>2)</sup> for mains disconnect [mm <sup>2</sup> ] ([AWG])	6,4,4 (10,12,12)							
Estimated power loss <sup>3)</sup> at rated maximum load [W] <sup>4)</sup>	35		50		65		92	
Efficiency <sup>5)</sup>	0.97		0.97		0.97		0.97	

7

Table 7.11 Mains Supply 3x525–600 V AC, PK75–P2K2

Type designation	P3K0		P4K0		P5K5		P7K5	
	HO	NO	HO	NO	HO	NO	HO	NO
High/normal overload <sup>1)</sup>								
Typical shaft output [kW]	3.0		4.0		5.5		7.5	
Typical shaft output [hp]	4		5		7.5		10	
Protection rating IP20/Chassis Protection rating IP21/Type 1	A2		A2		A3		A3	
IP55/Type 12	A5		A5		A5		A5	
<b>Output current</b>								
Continuous (3x525–550 V) [A]	5.2		6.4		9.5		11.5	
Intermittent (3x525–550 V) [A]	7.8	5.7	9.6	7.0	14.3	10.5	17.3	12.7
Continuous (3x551–600 V) [A]	4.9		6.1		9.0		11.0	
Intermittent (3x551–600 V) [A]	7.4	5.4	9.2	6.7	13.5	9.9	16.5	12.1
Continuous kVA at 550 V [kVA]	5.0		6.1		9.0		11.0	
Continuous kVA at 550 V [kVA]	4.9		6.1		9.0		11.0	
<b>Maximum input current</b>								
Continuous (3x525–600 V) [A]	5.2		5.8		8.6		10.4	
Intermittent (3x525–600 V) [A]	7.8	5.7	8.7	6.4	12.9	9.5	15.6	11.4
Maximum pre-fuses [A]	20		20		32		32	
<b>Additional specifications</b>								
Maximum cable cross-section <sup>2)</sup> for mains, motor, brake, and load sharing [mm <sup>2</sup> ] ([AWG])	4,4,4 (12,12,12) (minimum 0.2 (24))							
Maximum cable cross-section <sup>2)</sup> for mains disconnect [mm <sup>2</sup> ] ([AWG])	6,4,4 (10,12,12)							
Estimated power loss <sup>3)</sup> at rated maximum load [W] <sup>4)</sup>	122		145		195		261	
Efficiency <sup>5)</sup>	0.97		0.97		0.97		0.97	

**Table 7.12 Mains Supply 3x525–600 V AC, P3K0–P7K5**

Type designation	P11K		P15K		P18K		P22K		P30K		P37K	
High/normal overload <sup>1)</sup>	HO	NO	HO	NO	HO	NO	HO	NO	HO	NO	HO	NO
Typical shaft output [kW]	7.5	11	11	15	15	18.5	18.5	22	22	30	30	37
Typical shaft output [hp]	10	15	15	20	20	25	25	30	30	40	40	50
Protection rating IP20/ Chassis	B3		B3		B3		B4		B4		B4	
Protection rating IP21/ Type 1 Protection rating IP55/ Type 12 Protection rating IP66/ NEMA 4X	B1		B1		B1		B2		B2		C1	
<b>Output current</b>												
Continuous (3x525–550 V) [A]	11.5	19	19	23	23	28	28	36	36	43	43	54
Intermittent (3x525–550 V) [A]	18.4	21	30	25	37	31	45	40	58	47	65	59
Continuous (3x551–600 V) [A]	11	18	18	22	22	27	27	34	34	41	41	52
Intermittent (3x551–600 V) [A]	17.6	20	29	24	35	30	43	37	54	45	62	57
Continuous kVA at 550 V [kVA]	11	18.1	18.1	21.9	21.9	26.7	26.7	34.3	34.3	41.0	41.0	51.4
Continuous kVA at 575 V [kVA]	11	17.9	17.9	21.9	21.9	26.9	26.9	33.9	33.9	40.8	40.8	51.8
<b>Maximum input current</b>												
Continuous at 550 V [A]	10.4	17.2	17.2	20.9	20.9	25.4	25.4	32.7	32.7	39	39	49
Intermittent at 550 V [A]	16.6	19	28	23	33	28	41	36	52	43	59	54
Continuous at 575 V [A]	9.8	16	16	20	20	24	24	31	31	37	37	47
Intermittent at 575 V [A]	15.5	17.6	26	22	32	27	39	34	50	41	56	52
Maximum pre-fuses [A]	40		40		50		60		80		100	
<b>Additional specifications</b>												
Protection rating IP20, maximum cable cross- section <sup>2)</sup> for mains, brake, motor, and load sharing [mm <sup>2</sup> ] ([AWG])	10, 10,- (8, 8,-)						35,-,- (2,-,-)					
Protection ratings IP21, IP55, IP66 maximum cable cross-section <sup>2)</sup> for mains, brake, and load sharing [mm <sup>2</sup> ] ([AWG])	16, 10, 10 (6, 8, 8)						35,-,- (2,-,-)					
Protection ratings IP21, IP55, IP66 maximum cable cross-section <sup>2)</sup> for motor [mm <sup>2</sup> ] ([AWG])	10, 10,- (8, 8,-)						35, 25, 25 (2, 4, 4)					
Maximum cable cross- section <sup>2)</sup> for mains disconnect [mm <sup>2</sup> ] ([AWG])	16, 10, 10 (6, 8, 8)						50, 35, 35 (1, 2, 2)					
Estimated power loss <sup>3)</sup> at rated maximum load [W] <sup>4)</sup>	220	300	220	300	300	370	370	440	440	600	600	740
Efficiency <sup>5)</sup>	0.98		0.98		0.98		0.98		0.98		0.98	

**Table 7.13 Mains supply 3x525-600 V AC, P11K-P37K**

Type designation	P45K		P55K		P75K		P90K	
High/normal overload <sup>1)</sup>	HO	NO	HO	NO	HO	NO	HO	NO
Typical shaft output [kW]	37	45	45	55	55	75	75	90
Typical shaft output [hp]	50	60	60	75	75	100	100	125
Protection rating IP20/Chassis	C3		C3		C4		C4	
Protection rating IP21/Type 1	C1		C1		C2		C2	
Protection rating IP55/Type 12								
Protection rating IP66/NEMA 4X								
<b>Output current</b>								
Continuous (3x525–550 V) [A]	54	65	65	87	87	105	105	137
Intermittent (3x525–550 V) [A]	81	72	98	96	131	116	158	151
Continuous (3x525–600 V) [A]	52	62	62	83	83	100	100	131
Intermittent (3x525–600 V) [A]	78	68	93	91	125	110	150	144
Continuous kVA at 525 V [kVA]	51.4	61.9	61.9	82.9	82.9	100	100.0	130.5
Continuous kVA at 575 V [kVA]	51.8	61.7	61.7	82.7	82.7	99.6	99.6	130.5
<b>Maximum input current</b>								
Continuous at 550 V [A]	49	59	59	78.9	78.9	95.3	95.3	124.3
Intermittent at 550 V [A]	74	65	89	87	118	105	143	137
Continuous at 575 V [A]	47	56	56	75	75	91	91	119
Intermittent at 575 V [A]	70	62	85	83	113	100	137	131
Maximum pre-fuses [A]	150		160		225		250	
<b>Additional specifications</b>								
Protection rating IP20 maximum cable cross-section for mains and motor [mm <sup>2</sup> ] ([AWG])	50 (1)			150 (300 MCM)				
Protection rating IP20 maximum cable cross-section for brake and load sharing [mm <sup>2</sup> ] ([AWG])	50 (1)			95 (4/0)				
Protection ratings IP21, IP55, IP66 maximum cable cross-section for mains and motor [mm <sup>2</sup> ] ([AWG])	50 (1)			150 (300 MCM)				
Protection ratings IP21, IP55, IP66 maximum cable cross-section for brake and load sharing [mm <sup>2</sup> ] ([AWG])	50 (1)			95 (4/0)				
Maximum cable cross-section <sup>2)</sup> for mains disconnect [mm <sup>2</sup> ] ([AWG])	50, 35, 35 (1, 2, 2)			95, 70, 70 (3/0, 2/0, 2/0)			185, 150, 120 (350 MCM, 300 MCM, 4/0)	
Estimated power loss <sup>3)</sup> at rated maximum load [W] <sup>4)</sup>	740	900	900	1100	1100	1500	1500	1800
Efficiency <sup>5)</sup>	0.98		0.98		0.98		0.98	

**Table 7.14 Mains supply 3x525–600 V AC, P45K–P90K**

### 7.1.6 Mains Supply 3x525–690 V AC

Type designation	P1K1		P1K5		P2K2		P3K0		P4K0		P5K5		P7K5	
	HO	NO	HO	NO	HO	NO	HO	NO	HO	NO	HO	NO	HO	NO
High/normal overload <sup>1)</sup>														
Typical shaft output [kW]	1.1		1.5		2.2		3.0		4.0		5.5		7.5	
Typical shaft output [hp]	1.5		2		3		4		5		7.5		10	
Protection rating IP20/Chassis	A3		A3		A3		A3		A3		A3		A3	
<b>Output current</b>														
Continuous (3x525–550 V) [A]	2.1		2.7		3.9		4.9		6.1		9.0		11.0	
Intermittent (3x525–550 V) [A]	3.2	2.3	4.1	3.0	5.9	4.3	7.4	5.4	9.2	6.7	13.5	9.9	16.5	12.1
Continuous (3x551–690 V) [A]	1.6		2.2		3.2		4.5		5.5		7.5		10.0	
Intermittent (3x551–690 V) [A]	2.4	1.8	3.3	2.4	4.8	3.5	6.8	5.0	8.3	6.1	11.3	8.3	15.0	11.0
Continuous kVA at 525 V [kVA]	1.9		2.5		3.5		4.5		5.5		8.2		10.0	
Continuous kVA at 690 V [kVA]	1.9		2.6		3.8		5.4		6.6		9.0		12.0	
<b>Maximum input current</b>														
Continuous (3x525–550 V) [A]	1.9		2.4		3.5		4.4		5.5		8.1		9.9	
Intermittent (3x525–550 V) [A]	2.9	2.1	3.6	2.6	5.3	3.9	6.6	4.8	8.3	6.1	12.2	8.9	14.9	10.9
Continuous (3x551–690 V) [A]	1.4		2.0		2.9		4.0		4.9		6.7		9.0	
Intermittent (3x551–690 V) [A]	2.1	1.5	3.0	2.2	4.4	3.2	6.0	4.4	7.4	5.4	10.1	7.4	13.5	9.9
<b>Additional specifications</b>														
Maximum cable cross-section <sup>2)</sup> for mains, motor, brake, and load sharing [mm <sup>2</sup> ] ([AWG])	4, 4, 4 (12, 12, 12) (minimum 0.2 (24))													
Maximum cable cross-section <sup>2)</sup> for mains disconnect [mm <sup>2</sup> ] ([AWG])	6, 4, 4 (10, 12, 12)													
Estimated power loss <sup>3)</sup> at rated maximum load [W] <sup>4)</sup>	44		60		88		120		160		220		300	
Efficiency <sup>5)</sup>	0.96		0.96		0.96		0.96		0.96		0.96		0.96	

7

Table 7.15 A3 Enclosure, Mains Supply 3x525–690 V AC IP20/Protected Chassis, P1K1–P7K5

Type designation	P11K		P15K		P18K		P22K		P30K	
High/normal overload <sup>1)</sup>	HO	NO	HO	NO	HO	NO	HO	NO	HO	NO
Typical shaft output at 550 V [kW]	5.9	7.5	7.5	11	11	15	15	18.5	18.5	22
Typical shaft output at 550 V [hp]	7.5	10	10	15	15	20	20	25	25	30
Typical shaft output at 690 V [kW]	7.5	11	11	15	15	18.5	18.5	22	22	30
Typical shaft output at 690 V [hp]	10	15	15	20	20	25	25	30	30	40
Protection rating IP20/Chassis	B4		B4		B4		B4		B4	
Protection rating IP21/Type 1										
Protection rating IP55/Type 12	B2		B2		B2		B2		B2	
<b>Output current</b>										
Continuous (3x525–550 V) [A]	11	14	14.0	19.0	19.0	23.0	23.0	28.0	28.0	36.0
Intermittent (60 s overload) (3x525–550 V) [A]	17.6	15.4	22.4	20.9	30.4	25.3	36.8	30.8	44.8	39.6
Continuous (3x551–690 V) [A]	10	13	13.0	18.0	18.0	22.0	22.0	27.0	27.0	34.0
Intermittent (60 s overload) (3x551–690 V) [A]	16	14.3	20.8	19.8	28.8	24.2	35.2	29.7	43.2	37.4
Continuous kVA at 550 V [kVA]	10	13.3	13.3	18.1	18.1	21.9	21.9	26.7	26.7	34.3
Continuous kVA at 690 V [kVA]	12	15.5	15.5	21.5	21.5	26.3	26.3	32.3	32.3	40.6
<b>Maximum input current</b>										
Continuous at 550 V [A]	9.9	15	15.0	19.5	19.5	24.0	24.0	29.0	29.0	36.0
Intermittent (60 s overload) at 550 V [A]	15.8	16.5	23.2	21.5	31.2	26.4	38.4	31.9	46.4	39.6
Continuous (at 690 V) [A]	9	14.5	14.5	19.5	19.5	24.0	24.0	29.0	29.0	36.0
Intermittent (60 s overload) at 690 V [A]	14.4	16	23.2	21.5	31.2	26.4	38.4	31.9	46.4	39.6
<b>Additional specifications</b>										
Maximum cable cross-section <sup>2)</sup> for mains, motor, brake, and load sharing [mm <sup>2</sup> ] ([AWG])	35, 25, 25 (2, 4, 4)									
Maximum cable cross-section <sup>2)</sup> for mains disconnect [mm <sup>2</sup> ] ([AWG])	16,10,10 (6, 8, 8)									
Estimated power loss <sup>3)</sup> at rated maximum load [W] <sup>4)</sup>	150	220	150	220	220	300	300	370	370	440
Efficiency <sup>5)</sup>	0.98		0.98		0.98		0.98		0.98	

**Table 7.16 B2/B4 Enclosure, Mains Supply 3x525–690 V AC IP20/IP21/IP55, Chassis/NEMA 1/NEMA 12, P11K–P22K**

Type Designation	P37K		P45K		P55K		P75K/N75K <sup>8)</sup>		P90K/N90K <sup>8)</sup>	
	HO	NO	HO	NO	HO	NO	HO	NO	HO	NO
High/normal overload <sup>1)</sup>										
Typical shaft output at 550 V [kW]	22	30	30	37	37	45	45	55	55	75
Typical shaft output at 550 V [hp]	30	40	40	50	50	60	60	75	75	100
Typical shaft output at 690 V [kW]	30	37	37	45	45	55	55	75	75	90
Typical shaft output at 690 V [hp]	40	50	50	60	60	75	75	100	199	125
Protection rating IP20/Chassis	B4		C3		C3		D3h		D3h	
Protection rating IP21/Type 1										
Protection rating IP55/Type 12	C2		C2		C2		C2		C2	
<b>Output current</b>										
Continuous (3x525–550 V) [A]	36.0	43.0	43.0	54.0	54.0	65.0	65.0	87.0	87.0	105
Intermittent (60 s overload) (3x525–550 V) [A]	54.0	47.3	64.5	59.4	81.0	71.5	97.5	95.7	130.5	115.5
Continuous (3x551–690 V) [A]	34.0	41.0	41.0	52.0	52.0	62.0	62.0	83.0	83.0	100
Intermittent (60 s overload) (3x551–690 V) [A]	51.0	45.1	61.5	57.2	78.0	68.2	93.0	91.3	124.5	110
Continuous kVA at 550 V [kVA]	34.3	41.0	41.0	51.4	51.4	61.9	61.9	82.9	82.9	100
Continuous kVA at 690 V [kVA]	40.6	49.0	49.0	62.1	62.1	74.1	74.1	99.2	99.2	119.5
<b>Maximum input current</b>										
Continuous at 550 V [A]	36.0	49.0	49.0	59.0	59.0	71.0	71.0	87.0	87.0	99.0
Intermittent (60 s overload) at 550 V [A]	54.0	53.9	72.0	64.9	87.0	78.1	105.0	95.7	129	108.9
Continuous at 690 V [A]	36.0	48.0	48.0	58.0	58.0	70.0	70.0	86.0	-	-
Intermittent (60 s overload) at 690 V [A]	54.0	52.8	72.0	63.8	87.0	77.0	105	94.6	-	-
<b>Additional specifications</b>										
Maximum cable cross-section for mains and motor [mm <sup>2</sup> ] ([AWG])	150 (300 MCM)									
Maximum cable cross-section for brake and load sharing [mm <sup>2</sup> ] ([AWG])	95 (3/0)									
Maximum cable cross-section <sup>2)</sup> for mains disconnect [mm <sup>2</sup> ] ([AWG])	95 (3/0)						185, 150, 120 (350 MCM, 300 MCM, 4/0)		-	
Estimated power loss <sup>3)</sup> at rated maximum load [W] <sup>4)</sup>	600	740	740	900	900	1100	1100	1500	1500	1800
Efficiency <sup>5)</sup>	0.98		0.98		0.98		0.98		0.98	

**Table 7.17 B4, C2, C3 Enclosure, Mains Supply 3x525–690 V AC IP20/IP21/IP55, Chassis/NEMA1/NEMA 12, P30K–P75K**

For fuse ratings, see chapter 7.7 Fuses and Circuit Breakers.

1) High overload=150% or 160% torque for a duration of 60 s. Normal overload=110% torque for a duration of 60 s.

2) The 3 values for the maximum cable cross-section are for single core, flexible wire and flexible wire with sleeve, respectively.

3) Applies for dimensioning of frequency converter cooling. If the switching frequency is higher than the default setting, the power losses may increase. LCP and typical control card power consumptions are included. For power loss data according to EN 50598-2, refer to [www.danfoss.com/vltenergyefficiency](http://www.danfoss.com/vltenergyefficiency).

4) Efficiency measured at nominal current. For energy efficiency class see chapter 7.4 Ambient Conditions. For part load losses see [www.danfoss.com/vltenergyefficiency](http://www.danfoss.com/vltenergyefficiency).

5) Measured using 5 m screened motor cables at rated load and rated frequency.

6) Enclosure sizes A2+A3 can be converted to IP21 using a conversion kit. See also chapter 3.6 Mechanical Planning.

7) Enclosure sizes B3+B4 and C3+C4 can be converted to IP21 using a conversion kit. See also chapter 3.6 Mechanical Planning.

8) Enclosure sizes for N75K, N90K are D3h for IP20/Chassis, and D5h for IP54/Type 12.

9) 2 wires are required.

10) Variant not available in IP21.

## 7.2 Mains Supply

### Mains supply (L1, L2, L3)

Supply voltage	200–240 V ±10%
Supply voltage	380–480 V ±10%
Supply voltage	525–600 V ±10%

Supply voltage ..... 525–690 V  $\pm$ 10%

*Mains voltage low/mains drop-out:*

*During low mains voltage or a mains drop-out, the frequency converter continues until the intermediate circuit voltage drops below the minimum stop level. Typically this corresponds to 15% below the lowest rated supply voltage of the frequency converter. Power-up and full torque cannot be expected at mains voltage <10% below the lowest rated supply voltage of the frequency converter.*

Supply frequency ..... 50/60 Hz +4/-6%

*The frequency converter power supply is tested in accordance with IEC61000-4-28, 50 Hz +4/-6%.*

Maximum imbalance temporary between mains phases ..... 3.0% of rated supply voltage

True power factor ( $\lambda$ ) .....  $\geq$ 0.9 nominal at rated load

Displacement power factor ( $\cos\phi$ ) near unity ..... (>0.98)

Switching on input supply L1, L2, L3 (power-ups)  $\leq$ 7.5 kW ..... maximum 2 times/min.

Switching on input supply L1, L2, L3 (power-ups) 11–90 kW ..... maximum 1 time/min.

Environment according to EN 60664-1 ..... overvoltage category III/pollution degree 2

*The unit is suitable for use on a circuit capable of delivering not more than 100000 RMS symmetrical Amperes, 240/480/600/690 V maximum.*

7

### 7.3 Motor Output and Motor Data

**Motor output (U, V, W)**

Output voltage ..... 0–100% of supply voltage

Output frequency ..... 0–590 Hz<sup>1)</sup>

Switching on output ..... Unlimited

Ramp times ..... 1–3600 s

*1) Dependent on power size.*

**Torque characteristics, normal overload**

Starting torque (constant torque) ..... maximum 110% for 1 minute, once in 10 minutes<sup>2)</sup>

Overload torque (constant torque) ..... maximum 110% for 1 minute, once in 10 minutes<sup>2)</sup>

**Torque characteristics, high overload**

Starting torque (constant torque) ..... maximum 150/160% for 1 minute, once in 10 minutes<sup>2)</sup>

Overload torque (constant torque) ..... maximum 150/160% for 1 minute, once in 10 minutes<sup>2)</sup>

*2) Percentage relates to the nominal torque of the frequency converter, dependent on power size.*



## 7.4 Ambient Conditions

### Environment

Enclosure size A, protection ratings	IP20/Chassis, IP21/Type 1, IP55/Type 12, IP66/Type 4X
Enclosure size B1/B2, protection ratings	IP21/Type 1, IP55/Type 12, IP66/Type 4X
Enclosure size B3/B4, protection ratings	IP20/Chassis
Enclosure size C1/C2, protection ratings	IP21/Type 1, IP55/Type 12, IP66/Type 4X
Enclosure size C3/C4, protection ratings	IP20/Chassis
Enclosure kit available ≤ enclosure size A	IP21/TYPE 1/IP4X top
Vibration test enclosure A/B/C	1.0 g
Maximum relative humidity	5–95% (IEC 721-3-3; Class 3K3 (non-condensing) during operation
Aggressive environment (IEC 721-3-3), uncoated	class 3C2
Aggressive environment (IEC 721-3-3), coated	class 3C3
Test method according to IEC 60068-2-43 H2S (10 days)	
Ambient temperature	Maximum 50 °C

*Derating for high ambient temperature, see chapter 5 Special Conditions.*

Minimum ambient temperature during full-scale operation	0 °C
Minimum ambient temperature at reduced performance	-10 °C
Temperature during storage/transport	-25 to +65/70 °C
Maximum altitude above sea level without derating	1000 m
Maximum altitude above sea level with derating	3000 m

*Derating for high altitude, see chapter 5 Special Conditions.*

EMC standards, Emission	EN 61800-3
EMC standards, Immunity	EN 61800-3
Energy efficiency class <sup>1)</sup>	IE2

*1) Determined according to EN50598-2 at:*

- Rated load
- 90% rated frequency
- Switching frequency factory setting
- Switching pattern factory setting

## 7.5 Cable Specifications

Maximum motor cable length, screened/armoured	150 m
Maximum motor cable length, unscreened/unarmoured	300 m
Maximum cross section to motor, mains, load sharing and brake <sup>1)</sup>	
Maximum cross section to control terminals, rigid wire	1.5 mm <sup>2</sup> /16 AWG (2 x 0.75 mm <sup>2</sup> )
Maximum cross section to control terminals, flexible cable	1 mm <sup>2</sup> /18 AWG
Maximum cross section to control terminals, cable with enclosed core	0.5 mm <sup>2</sup> /20 AWG
Minimum cross section to control terminals	0.25 mm <sup>2</sup>

*1) See electrical data tables in chapter 7.1 Electrical Data for more information.*

It is mandatory to ground the mains connection properly using T95 (PE) of the frequency converter. The ground connection cable cross section must be at least 10 mm<sup>2</sup> or 2 rated mains wires terminated separately according to EN 50178. See also chapter 3.2.8 Earth Leakage Current. Use unscreened cable.

### 7.5.1 Cable Lengths for Multiple Parallel Motor Connections

Enclosure sizes	Power Size [kW]	Voltage [V]	1 cable [m]	2 cables [m]	3 cables [m]	4 cables [m]
A1, A2, A4, A5	0.37–0.75	400	150	45	8	6
		500	150	7	4	3
A2, A4, A5	1.1–1.5	400	150	45	20	8
		500	150	45	5	4
A2, A4, A5	2.2–4	400	150	45	20	11
		500	150	45	20	6
A3, A4, A5	5.5–7.5	400	150	45	20	11
		500	150	45	20	11
B1, B2, B3, B4, C1, C2, C3, C4	11–75	400	150	75	50	37
		500	150	75	50	37
A3	1.1–7.5	525–690	100	50	33	25
B4	11–30	525–690	150	75	50	37
C3	37–45	525–690	150	75	50	37

Table 7.18 Maximum Cable Length for Each Parallel Cable<sup>1)</sup>

1) For more information, refer to chapter 3.4.6 Connection of Multiple Motors.

### 7.6 Control Input/Output and Control Data

Control card, RS485 serial communication

Terminal number	68 (P,TX+, RX+), 69 (N,TX-, RX-)
Terminal number 61	common for terminals 68 and 69

The RS485 serial communication circuit is functionally separated from other central circuits and galvanically isolated from the supply voltage (PELV).

Analog inputs

Number of analog inputs	2
Terminal number	53, 54
Modes	voltage or current
Mode select	switches S201 and S202
Voltage mode	switch S201/S202 = OFF (U)
Voltage level	0-10 V (scaleable)
Input resistance, R <sub>i</sub>	approx. 10 kΩ
Maximum voltage	±20 V
Current mode	switch S201/S202=On (I)
Current level	0/4-20 mA (scaleable)
Input resistance, R <sub>i</sub>	approx. 200 Ω
Maximum current	30 mA
Resolution for analog inputs	10 bit (+ sign)
Accuracy of analog inputs	maximum error 0.5% of full scale
Bandwidth	200 Hz

The analog inputs are galvanically isolated from the supply voltage (PELV) and other high-voltage terminals.

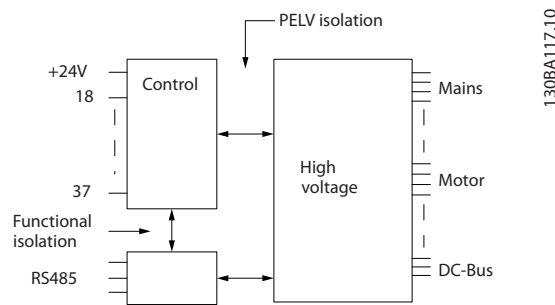


Illustration 7.1 PELV Isolation of Analog Inputs

Analog output

Number of programmable analog outputs	1
Terminal number	42
Current range at analog output	0/4–20 mA
Maximum resistor load to common at analog output	500 Ω
Accuracy on analog output	maximum error 0.8% of full scale
Resolution on analog output	8 bit

The analog output is galvanically isolated from the supply voltage (PELV) and other high-voltage terminals.

Digital inputs

Programmable digital inputs	4 (6)
Terminal number	18, 19, 27 <sup>1)</sup> , 29 <sup>1)</sup> , 32, 33,
Logic	PNP or NPN
Voltage level	0–24 V DC
Voltage level, logic 0 PNP	<5 V DC
Voltage level, logic 1 PNP	>10 V DC
Voltage level, logic 0 NPN	>19 V DC
Voltage level, logic '1' NPN	<14 V DC
Maximum voltage on input	28 V DC
Input resistance, R <sub>i</sub>	approx. 4 kΩ

All digital inputs are galvanically isolated from the supply voltage (PELV) and other high-voltage terminals.

1) Terminals 27 and 29 can also be programmed as output.

Digital output

Programmable digital/pulse outputs	2
Terminal number	27, 29 <sup>1)</sup>
Voltage level at digital/frequency output	0–24 V
Maximum output current (sink or source)	40 mA
Maximum load at frequency output	1 kΩ
Maximum capacitive load at frequency output	10 nF
Minimum output frequency at frequency output	0 Hz
Maximum output frequency at frequency output	32 kHz
Accuracy of frequency output	maximum error 0.1% of full scale
Resolution of frequency outputs	12 bit

1) Terminal 27 and 29 can also be programmed as input.

The digital output is galvanically isolated from the supply voltage (PELV) and other high-voltage terminals.

Pulse inputs

Programmable pulse inputs	2
Terminal number pulse	29, 33
Maximum frequency at terminal 29, 33	110 kHz (push-pull driven)
Maximum frequency at terminal 29, 33	5 kHz (open collector)
Minimum frequency at terminal 29, 33	4 Hz

Voltage level	see <i>Digital inputs</i>
Maximum voltage on input	28 V DC
Input resistance, $R_i$	approx. 4 k $\Omega$
Pulse input accuracy (0.1–1 kHz)	maximum error 0.1% of full scale

**Control card, 24 V DC output**

Terminal number	12, 13
Maximum load	200 mA

*The 24 V DC supply is galvanically isolated from the supply voltage (PELV), but has the same potential as the analog and digital inputs and outputs.*

**Relay outputs**

Programmable relay outputs	2
<b>Relay 01 terminal number</b>	1-3 (break), 1-2 (make)
Maximum terminal load (AC-1) <sup>1)</sup> on 1-3 (NC), 1-2 (NO) (resistive load)	240 V AC, 2 A
Maximum terminal load (AC-15) <sup>1)</sup> (inductive load @ cos $\phi$ 0.4)	240 V AC, 0.2 A
Maximum terminal load (DC-1) <sup>1)</sup> on 1-2 (NO), 1-3 (NC) (resistive load)	60 V DC, 1 A
Maximum terminal load (DC-13) <sup>1)</sup> (inductive load)	24 V DC, 0.1 A
<b>Relay 02 terminal number</b>	4-6 (break), 4-5 (make)
Maximum terminal load (AC-1) <sup>1)</sup> on 4-5 (NO) (resistive load) <sup>2) 3)</sup>	400 V AC, 2 A
Maximum terminal load (AC-15) <sup>1)</sup> on 4-5 (NO) (inductive load @ cos $\phi$ 0.4)	240 V AC, 0.2 A
Maximum terminal load (DC-1) <sup>1)</sup> on 4-5 (NO) (resistive load)	80 V DC, 2 A
Maximum terminal load (DC-13) <sup>1)</sup> on 4-5 (NO) (inductive load)	24 V DC, 0.1 A
Maximum terminal load (AC-1) <sup>1)</sup> on 4-6 (NC) (resistive load)	240 V AC, 2 A
Maximum terminal load (AC-15) <sup>1)</sup> on 4-6 (NC) (inductive load @ cos $\phi$ 0.4)	240 V AC, 0.2 A
Maximum terminal load (DC-1) <sup>1)</sup> on 4-6 (NC) (resistive load)	50 V DC, 2 A
Maximum terminal load (DC-13) <sup>1)</sup> on 4-6 (NC) (inductive load)	24 V DC, 0.1 A
Minimum terminal load on 1-3 (NC), 1-2 (NO), 4-6 (NC), 4-5 (NO)	24 V DC, 10 mA, 24 V AC, 20 mA
Environment according to EN 60664-1	overvoltage category III/pollution degree 2

1) IEC 60947 parts 4 and 5.

*The relay contacts are galvanically isolated from the rest of the circuit by reinforced isolation (PELV).*

2) Overvoltage category II.

3) UL applications 300 V AC 2 A.

**Control card, 10 V DC output**

Terminal number	50
Output voltage	10.5 V $\pm$ 0.5 V
Maximum load	25 mA

*The 10 V DC supply is galvanically isolated from the supply voltage (PELV) and other high-voltage terminals.*

**Control characteristics**

Resolution of output frequency at 0–590 Hz	$\pm$ 0.003 Hz
System response time (terminals 18, 19, 27, 29, 32, 33)	$\leq$ 2 ms
Speed control range (open loop)	1:100 of synchronous speed
Speed accuracy (open loop)	30–4000 RPM: maximum error of $\pm$ 8 RPM

*All control characteristics are based on a 4-pole asynchronous motor.*

**Control card performance**

Scan interval	5 ms
---------------	------

Control card, USB serial communication

USB standard 1.1 (full speed)

USB plug USB type B "device" plug

### **CAUTION**

Connection to a PC is carried out via a standard host/device USB cable.

The USB connection is galvanically isolated from the supply voltage (PELV) and other high-voltage terminals.

The USB connection is not galvanically isolated from protective earth. Use only an isolated laptop/PC as a connection to the USB connector on the frequency converter, or an isolated USB cable/converter.

## 7.7 Fuses and Circuit Breakers

Use recommended fuses and/or circuit breakers on the supply side as protection in case of component break-down inside the frequency converter (first fault).

### **NOTICE**

Use of fuses on the supply side is mandatory for IEC 60364 (CE) and NEC 2009 (UL) compliant installations.

#### Recommendations:

- gG type fuses.
- Moeller type circuit breakers. For other circuit breaker types, ensure that the energy into the frequency converter is equal to or lower than the energy provided by Moeller types.

Use of recommended fuses and circuit breakers ensures that possible damage to the frequency converter is limited to damages inside the unit. For further information, see *Application Note Fuses and Circuit Breakers*.

The fuses below are suitable for use on a circuit capable of delivering 100000 A<sub>rms</sub> (symmetrical), depending on the frequency converter voltage rating. With the proper fusing, the frequency converter short-circuit current rating (SCCR) is 100000 A<sub>rms</sub>.

## 7.7.1 CE Compliance

## 200–240 V, Enclosure sizes A, B, and C

Enclosure	Power [kW]	Recommended fuse size	Recommended maximum fuse	Recommended circuit breaker Moeller	Maximum trip level [A]
A2	0.25–2.2	gG-10 (0.25–1.5) gG-16 (2.2)	gG-25	PKZM0-25	25
A3	3.0–3.7	gG-16 (3) gG-20 (3.7)	gG-32	PKZM0-25	25
A4	0.25–2.2	gG-10 (0.25–1.5) gG-16 (2.2)	gG-32	PKZM0-25	25
A5	0.25–3.7	gG-10 (0.25–1.5) gG-16 (2.2–3) gG-20 (3.7)	gG-32	PKZM0-25	25
B1	5.5–11	gG-25 (5.5) gG-32 (7.5)	gG-80	PKZM4-63	63
B2	15	gG-50	gG-100	NZMB1-A100	100
B3	5.5–11	gG-25	gG-63	PKZM4-50	50
B4	15–18	gG-32 (7.5) gG-50 (11) gG-63 (15)	gG-125	NZMB1-A100	100
C1	18.5–30	gG-63 (15) gG-80 (18.5) gG-100 (22)	gG-160 (15–18.5) aR-160 (22)	NZMB2-A200	160
C2	37–45	aR-160 (30) aR-200 (37)	aR-200 (30) aR-250 (37)	NZMB2-A250	250
C3	22–30	gG-80 (18.5) aR-125 (22)	gG-150 (18.5) aR-160 (22)	NZMB2-A200	150
C4	37–45	aR-160 (30) aR-200 (37)	aR-200 (30) aR-250 (37)	NZMB2-A250	250

Table 7.19 200–240 V, Enclosure Sizes A, B, and C

38–480 V, Enclosure Sizes A, B, and C

Enclosure	Power [kW]	Recommended fuse size	Recommended maximum fuse	Recommended circuit breaker Moeller	Maximum trip level [A]
A2	1.1–4.0	gG-10 (0.37-3) gG-16 (4)	gG-25	PKZM0-25	25
A3	5.5–7.5	gG-16	gG-32	PKZM0-25	25
A4	1.1–4.0	gG-10 (0.37-3) gG-16 (4)	gG-32	PKZM0-25	25
A5	1.1–7.5	gG-10 (0.37-3) gG-16 (4-7.5)	gG-32	PKZM0-25	25
B1	11–18.5	gG-40	gG-80	PKZM4-63	63
B2	22–30	gG-50 (18.5) gG-63 (22)	gG-100	NZMB1-A100	100
B3	11–18	gG-40	gG-63	PKZM4-50	50
B4	22–37	gG-50 (18.5) gG-63 (22) gG-80 (30)	gG-125	NZMB1-A100	100
C1	37–55	gG-80 (30) gG-100 (37) gG-160 (45)	gG-160	NZMB2-A200	160
C2	75–90	aR-200 (55) aR-250 (75)	aR-250	NZMB2-A250	250
C3	45–55	gG-100 (37) gG-160 (45)	gG-150 (37) gG-160 (45)	NZMB2-A200	150
C4	75–90	aR-200 (55) aR-250 (75)	aR-250	NZMB2-A250	250

7

Table 7.20 380–480 V, Enclosure Sizes A, B, and C

525–600 V, Enclosure Sizes A, B, and C

Enclosure	Power [kW]	Recommended fuse size	Recommended maximum fuse	Recommended circuit breaker Moeller	Maximum trip level [A]
A2	1.1–4.0	gG-10	gG-25	PKZM0-25	25
A3	5.5–7.5	gG-10 (5.5) gG-16 (7.5)	gG-32	PKZM0-25	25
A5	1.1–7.5	gG-10 (0.75-5.5) gG-16 (7.5)	gG-32	PKZM0-25	25
B1	11–18	gG-25 (11) gG-32 (15) gG-40 (18.5)	gG-80	PKZM4-63	63
B2	22–30	gG-50 (22) gG-63 (30)	gG-100	NZMB1-A100	100
B3	11–18.5	gG-25 (11) gG-32 (15)	gG-63	PKZM4-50	50
B4	22–37	gG-40 (18.5) gG-50 (22) gG-63 (30)	gG-125	NZMB1-A100	100
C1	37–55	gG-63 (37) gG-100 (45) aR-160 (55)	gG-160 (37-45) aR-250 (55)	NZMB2-A200	160
C2	75–90	aR-200 (75)	aR-250	NZMB2-A250	250
C3	45–55	gG-63 (37) gG-100 (45)	gG-150	NZMB2-A200	150
C4	75–90	aR-160 (55) aR-200 (75)	aR-250	NZMB2-A250	250

Table 7.21 52–600 V, Enclosure Sizes A, B, and C

525–690 V, Enclosure Sizes A, B, and C

Enclosure	Power [kW]	Recommended fuse size	Recommended maximum fuse	Recommended circuit breaker Danfoss	Maximum trip level [A]
A3	1.1	gG-6	gG-25	CTI25M 10-16	16
	1.5	gG-6	gG-25	CTI25M 10-16	16
	2.2	gG-6	gG-25	CTI25M 10-16	16
	3	gG-10	gG-25	CTI25M 10-16	16
	4	gG-10	gG-25	CTI25M 10-16	16
	5.5	gG-16	gG-25	CTI25M 10-16	16
	7.5	gG-16	gG-25	CTI25M 10-16	16
B2	11	gG-25	gG-63		
	15	gG-25	gG-63		
	18	gG-32			
	22	gG-32			
C2	30	gG-40			
	37	gG-63	gG-80		
	45	gG-63	gG-100		
	55	gG-80	gG-125		
	75	gG-100	gG-160		
C3	37	gG-100	gG-125		
	45	gG-125	gG-160		

Table 7.22 525–690 V, Enclosure Sizes A, B, and C



## 7.7.2 UL Compliance

### 1x200–240 V, Enclosure Sizes A, B, and C

Recommended maximum fuse													
Power [kW]	Max. pre-fuse size [A]	Bussmann JFHR2	Bussmann RK1	Bussmann J	Bussmann T	Bussmann CC	Bussmann CC	Bussmann CC	SIBA RK1	Littel fuse RK1	Ferraz-Shawmut CC	Ferraz-Shawmut RK1	Ferraz-Shawmut J
1.1	15	FWX-15	KTN-R15	JKS-15	JJN-15	FNQ-R-15	KTK-R-15	LP-CC-15	5017906-016	KLN-R15	ATM-R15	A2K-15R	HSJ15
1.5	20	FWX-20	KTN-R20	JKS-20	JJN-20	FNQ-R-20	KTK-R-20	LP-CC-20	5017906-020	KLN-R20	ATM-R20	A2K-20R	HSJ20
2.2	30 <sup>1)</sup>	FWX-30	KTN-R30	JKS-30	JJN-30	FNQ-R-30	KTK-R-30	LP-CC-30	5012406-032	KLN-R30	ATM-R30	A2K-30R	HSJ30
3.0	35	FWX-35	KTN-R35	JKS-35	JJN-35	---	---	---	---	KLN-R35	---	A2K-35R	HSJ35
3.7	50	FWX-50	KTN-R50	JKS-50	JJN-50	---	---	---	5014006-050	KLN-R50	---	A2K-50R	HSJ50
5.5	60 <sup>2)</sup>	FWX-60	KTN-R60	JKS-60	JJN-60	---	---	---	5014006-063	KLN-R60	---	A2K-60R	HSJ60
7.5	80	FWX-80	KTN-R80	JKS-80	JJN-80	---	---	---	5014006-080	KLN-R80	---	A2K-80R	HSJ80
15	150	FWX-150	KTN-R150	JKS-150	JJN-150	---	---	---	2028220-150	KLN-R150	---	A2K-150R	HSJ150
22	200	FWX-200	KTN-R200	JKS-200	JJN-200	---	---	---	2028220-200	KLN-R200	---	A2K-200R	HSJ200

Table 7.23 1x200–240 V, Enclosure Sizes A, B, and C

1) Siba allowed up to 32 A.

2) Siba allowed up to 63 A.

### 1x380–500 V, Enclosure Sizes B and C

Recommended maximum fuse													
Power [kW]	Max. pre-fuse size [A]	Bussmann JFHR2	Bussmann RK1	Bussmann J	Bussmann T	Bussmann CC	Bussmann CC	Bussmann CC	SIBA RK1	Littel fuse RK1	Ferraz-Shawmut CC	Ferraz-Shawmut RK1	Ferraz-Shawmut J
7.5	60	FWH-60	KTS-R60	JKS-60	JJS-60				5014006-063	KLS-R60	-	A6K-60R	HSJ60
11	80	FWH-80	KTS-R80	JKS-80	JJS-80				2028220-100	KLS-R80	-	A6K-80R	HSJ80
22	150	FWH-150	KTS-R150	JKS-150	JJS-150				2028220-160	KLS-R150	-	A6K-150R	HSJ150
37	200	FWH-200	KTS-R200	JKS-200	JJS-200				2028220-200	KLS-200		A6K-200R	HSJ200

Table 7.24 1x380–500 V, Enclosure Sizes B and C

- KTS-fuses from Bussmann may substitute KTN for 240 V frequency converters.
- FWH-fuses from Bussmann may substitute FWX for 240 V frequency converters.
- JJS-fuses from Bussmann may substitute JJN for 240 V frequency converters.
- KLSR fuses from Littel fuse may substitute KLN-R fuses for 240 V frequency converters.
- A6KR fuses from Ferraz-Shawmut may substitute A2KR for 240 V frequency converters.

3x200–240 V, Enclosure Sizes A, B, and C

Power [kW]	Recommended maximum fuse					
	Bussmann Type RK1 <sup>1)</sup>	Bussmann Type J	Bussmann Type T	Bussmann Type CC	Bussmann	Bussmann Type CC
0.25–0.37	KTN-R-05	JKS-05	JJN-05	FNQ-R-5	KTK-R-5	LP-CC-5
0.55–1.1	KTN-R-10	JKS-10	JJN-10	FNQ-R-10	KTK-R-10	LP-CC-10
1.5	KTN-R-15	JKS-15	JJN-15	FNQ-R-15	KTK-R-15	LP-CC-15
2.2	KTN-R-20	JKS-20	JJN-20	FNQ-R-20	KTK-R-20	LP-CC-20
3.0	KTN-R-25	JKS-25	JJN-25	FNQ-R-25	KTK-R-25	LP-CC-25
3.7	KTN-R-30	JKS-30	JJN-30	FNQ-R-30	KTK-R-30	LP-CC-30
5.5–7.5	KTN-R-50	JKS-50	JJN-50	-	-	-
11	KTN-R-60	JKS-60	JJN-60	-	-	-
15	KTN-R-80	JKS-80	JJN-80	-	-	-
18.5–22	KTN-R-125	JKS-125	JJN-125	-	-	-
30	KTN-R-150	JKS-150	JJN-150	-	-	-
37	KTN-R-200	JKS-200	JJN-200	-	-	-
45	KTN-R-250	JKS-250	JJN-250	-	-	-

Table 7.25 3x200–240 V, Enclosure Sizes A, B, and C

Power [kW]	Recommended maximum fuse							
	SIBA Type RK1	Littel fuse Type RK1	Ferraz-Shawmut Type CC	Ferraz-Shawmut Type RK1 <sup>2)</sup>	Bussmann Type JFHR2 <sup>3)</sup>	Littel fuse JFHR2	Ferraz-Shawmut JFHR2 <sup>4)</sup>	Ferraz-Shawmut J
0.25–0.37	5017906-005	KLN-R-05	ATM-R-05	A2K-05-R	FWX-5	-	-	HSJ-6
0.55–1.1	5017906-010	KLN-R-10	ATM-R-10	A2K-10-R	FWX-10	-	-	HSJ-10
1.5	5017906-016	KLN-R-15	ATM-R-15	A2K-15-R	FWX-15	-	-	HSJ-15
2.2	5017906-020	KLN-R-20	ATM-R-20	A2K-20-R	FWX-20	-	-	HSJ-20
3.0	5017906-025	KLN-R-25	ATM-R-25	A2K-25-R	FWX-25	-	-	HSJ-25
3.7	5012406-032	KLN-R-30	ATM-R-30	A2K-30-R	FWX-30	-	-	HSJ-30
5.5–7.5	5014006-050	KLN-R-50	-	A2K-50-R	FWX-50	-	-	HSJ-50
11	5014006-063	KLN-R-60	-	A2K-60-R	FWX-60	-	-	HSJ-60
15	5014006-080	KLN-R-80	-	A2K-80-R	FWX-80	-	-	HSJ-80
18.5–22	2028220-125	KLN-R-125	-	A2K-125-R	FWX-125	-	-	HSJ-125
30	2028220-150	KLN-R-150	-	A2K-150-R	FWX-150	L25S-150	A25X-150	HSJ-150
37	2028220-200	KLN-R-200	-	A2K-200-R	FWX-200	L25S-200	A25X-200	HSJ-200
45	2028220-250	KLN-R-250	-	A2K-250-R	FWX-250	L25S-250	A25X-250	HSJ-250

Table 7.26 3x200–240 V, Enclosure Sizes A, B, and C

- 1) KTS-fuses from Bussmann may substitute KTN for 240 V frequency converters.
- 2) A6KR fuses from Ferraz-Shawmut may substitute A2KR for 240 V frequency converters.
- 3) FWH-fuses from Bussmann may substitute FWX for 240 V frequency converters.
- 4) A50X fuses from Ferraz-Shawmut may substitute A25X for 240 V frequency converters.

7

3x380–480 V, Enclosure Sizes A, B, and C

Power [kW]	Recommended maximum fuse					
	Bussmann Type RK1	Bussmann Type J	Bussmann Type T	Bussmann Type CC	Bussmann Type CC	Bussmann Type CC
-	KTS-R-6	JKS-6	JJS-6	FNQ-R-6	KTK-R-6	LP-CC-6
1.1–2.2	KTS-R-10	JKS-10	JJS-10	FNQ-R-10	KTK-R-10	LP-CC-10
3	KTS-R-15	JKS-15	JJS-15	FNQ-R-15	KTK-R-15	LP-CC-15
4	KTS-R-20	JKS-20	JJS-20	FNQ-R-20	KTK-R-20	LP-CC-20
5.5	KTS-R-25	JKS-25	JJS-25	FNQ-R-25	KTK-R-25	LP-CC-25
7.5	KTS-R-30	JKS-30	JJS-30	FNQ-R-30	KTK-R-30	LP-CC-30
11	KTS-R-40	JKS-40	JJS-40	-	-	-
15	KTS-R-50	JKS-50	JJS-50	-	-	-
22	KTS-R-60	JKS-60	JJS-60	-	-	-
30	KTS-R-80	JKS-80	JJS-80	-	-	-
37	KTS-R-100	JKS-100	JJS-100	-	-	-
45	KTS-R-125	JKS-125	JJS-125	-	-	-
55	KTS-R-150	JKS-150	JJS-150	-	-	-
75	KTS-R-200	JKS-200	JJS-200	-	-	-
90	KTS-R-250	JKS-250	JJS-250	-	-	-

7

Table 7.27 3x380–480 V, Enclosure Sizes A, B, and C

Power [kW]	Recommended maximum fuse							
	SIBA Type RK1	Littel fuse Type RK1	Ferraz-Shawmut Type CC	Ferraz-Shawmut Type RK1	Bussmann JFHR2	Ferraz-Shawmut J	Ferraz-Shawmut JFHR2 <sup>1)</sup>	Littel fuse JFHR2
-	5017906-006	KLS-R-6	ATM-R-6	A6K-6-R	FWH-6	HSJ-6	-	-
1.1–2.2	5017906-010	KLS-R-10	ATM-R-10	A6K-10-R	FWH-10	HSJ-10	-	-
3	5017906-016	KLS-R-15	ATM-R-15	A6K-15-R	FWH-15	HSJ-15	-	-
4	5017906-020	KLS-R-20	ATM-R-20	A6K-20-R	FWH-20	HSJ-20	-	-
5.5	5017906-025	KLS-R-25	ATM-R-25	A6K-25-R	FWH-25	HSJ-25	-	-
7.5	5012406-032	KLS-R-30	ATM-R-30	A6K-30-R	FWH-30	HSJ-30	-	-
11	5014006-040	KLS-R-40	-	A6K-40-R	FWH-40	HSJ-40	-	-
15	5014006-050	KLS-R-50	-	A6K-50-R	FWH-50	HSJ-50	-	-
22	5014006-063	KLS-R-60	-	A6K-60-R	FWH-60	HSJ-60	-	-
30	2028220-100	KLS-R-80	-	A6K-80-R	FWH-80	HSJ-80	-	-
37	2028220-125	KLS-R-100	-	A6K-100-R	FWH-100	HSJ-100	-	-
45	2028220-125	KLS-R-125	-	A6K-125-R	FWH-125	HSJ-125	-	-
55	2028220-160	KLS-R-150	-	A6K-150-R	FWH-150	HSJ-150	-	-
75	2028220-200	KLS-R-200	-	A6K-200-R	FWH-200	HSJ-200	A50-P-225	L50-S-225
90	2028220-250	KLS-R-250	-	A6K-250-R	FWH-250	HSJ-250	A50-P-250	L50-S-250

Table 7.28 3x380–480 V, Enclosure Sizes A, B, and C

1) Ferraz-Shawmut A50QS fuses may substitute A50P fuses.

3x525–600 V, Enclosure Sizes A, B, and C

Power [kW]	Recommended maximum fuse									
	Bussmann Type RK1	Bussman n Type J	Bussmann Type T	Bussmann Type CC	Bussman n Type CC	Bussman n Type CC	SIBA Type RK1	Littel fuse Type RK1	Ferraz-Shawmut Type RK1	Ferraz-Shawmut J
0.75–1.1	KTS-R-5	JKS-5	JJS-6	FNQ-R-5	KTK-R-5	LP-CC-5	5017906-005	KLS-R-005	A6K-5-R	HSJ-6
1.5–2.2	KTS-R-10	JKS-10	JJS-10	FNQ-R-10	KTK-R-10	LP-CC-10	5017906-010	KLS-R-010	A6K-10-R	HSJ-10
3	KTS-R15	JKS-15	JJS-15	FNQ-R-15	KTK-R-15	LP-CC-15	5017906-016	KLS-R-015	A6K-15-R	HSJ-15
4	KTS-R20	JKS-20	JJS-20	FNQ-R-20	KTK-R-20	LP-CC-20	5017906-020	KLS-R-020	A6K-20-R	HSJ-20
5.5	KTS-R-25	JKS-25	JJS-25	FNQ-R-25	KTK-R-25	LP-CC-25	5017906-025	KLS-R-025	A6K-25-R	HSJ-25
7.5	KTS-R-30	JKS-30	JJS-30	FNQ-R-30	KTK-R-30	LP-CC-30	5017906-030	KLS-R-030	A6K-30-R	HSJ-30
11–15	KTS-R-35	JKS-35	JJS-35	-	-	-	5014006-040	KLS-R-035	A6K-35-R	HSJ-35
18	KTS-R-45	JKS-45	JJS-45	-	-	-	5014006-050	KLS-R-045	A6K-45-R	HSJ-45
22	KTS-R-50	JKS-50	JJS-50	-	-	-	5014006-050	KLS-R-050	A6K-50-R	HSJ-50
30	KTS-R-60	JKS-60	JJS-60	-	-	-	5014006-063	KLS-R-060	A6K-60-R	HSJ-60
37	KTS-R-80	JKS-80	JJS-80	-	-	-	5014006-080	KLS-R-075	A6K-80-R	HSJ-80
45	KTS-R-100	JKS-100	JJS-100	-	-	-	5014006-100	KLS-R-100	A6K-100-R	HSJ-100
55	KTS-R-125	JKS-125	JJS-125	-	-	-	2028220-125	KLS-R-125	A6K-125-R	HSJ-125
75	KTS-R-150	JKS-150	JJS-150	-	-	-	2028220-150	KLS-R-150	A6K-150-R	HSJ-150
90	KTS-R-175	JKS-175	JJS-175	-	-	-	2028220-200	KLS-R-175	A6K-175-R	HSJ-175

Table 7.29 3x525–600 V, Enclosure Sizes A, B, and C

3x525–690 V, Enclosure Sizes B and C

Power [kW]	Recommended maximum fuse							
	Maximum pre-fuse [A]	Bussmann E52273 RK1/JDDZ	Bussmann E4273 J/JDDZ	Bussmann E4273 T/JDDZ	SIBA E180276 RK1/JDDZ	LittelFuse E81895 RK1/JDDZ	Ferraz-Shawmut E163267/E2137 RK1/JDDZ	Ferraz-Shawmut E2137 J/HSJ
11–15	30	KTS-R-30	JKS-30	JJS-30	5017906-030	KLS-R-030	A6K-30-R	HST-30
22	45	KTS-R-45	JKS-45	JJS-45	5014006-050	KLS-R-045	A6K-45-R	HST-45
30	60	KTS-R-60	JKS-60	JJS-60	5014006-063	KLS-R-060	A6K-60-R	HST-60
37	80	KTS-R-80	JKS-80	JJS-80	5014006-080	KLS-R-075	A6K-80-R	HST-80
45	90	KTS-R-90	JKS-90	JJS-90	5014006-100	KLS-R-090	A6K-90-R	HST-90
55	100	KTS-R-100	JKS-100	JJS-100	5014006-100	KLS-R-100	A6K-100-R	HST-100
75	125	KTS-R-125	JKS-125	JJS-125	2028220-125	KLS-150	A6K-125-R	HST-125
90	150	KTS-R-150	JKS-150	JJS-150	2028220-150	KLS-175	A6K-150-R	HST-150

Table 7.30 3x525–690 V, Enclosure Sizes B and C

7.8 Power Ratings, Weight and Dimensions

Enclosure size [kW]	A2	A3	A4	A5	B1	B2	B3	B4	C1	C2	C3	C4
1x200-240 V	S2	1.1	1.1-2.2	1.1	1.5-3.7	7.5	-	-	15	22	-	-
3x200-240 V	T2	3.7	0.25-2.2	0.25-3.7	5.5-11	15	5.5-11	15-18.5	18.5-30	37-45	22-30	37-45
1x380-480 V	S4	-	1.1-4.0	-	7.5	11	-	-	18	37	-	-
3x380-480 V	T4	5.5-7.5	0.37-4.0	0.37-7.5	11-18.5	22-30	11-18.5	22-37	37-55	75-90	45-55	75-90
3x525-600 V	T6	0.75-7.5	-	0.75-7.5	11-18.5	22-30	11-18.5	22-37	37-55	75-90	45-55	75-90
3x525-690 V	T7	-	-	-	-	11-30	-	-	-	37-90	-	-
IP	20	20	55/66	55/66	21/55/66	21/55/66	20	20	21/55/66	21/55/66	20	20
NEMA	Chassis Type 1	Chassis Type 1	Type 12/4X	Type 12/4X	Type 1/12/4X	Type 1/12/4X	Chassis	Chassis	Type 1/12/4X	Type 1/12/4X	Chassis	Chassis
<b>Height [mm]</b>												
Height of back plate	A	268	375	390	420	480	399	520	680	770	550	660
Height with de-coupling plate for fieldbus cables	A	374	-	-	-	-	419	595	-	-	630	800
Distance between mounting holes	a	257	350	401	402	454	380	495	648	739	521	631
<b>Width [mm]</b>												
Width of back plate	B	90	130	200	242	242	165	231	308	370	308	370
Width of back plate with 1 C option	B	130	170	-	242	242	205	231	308	370	308	370
Width of back plate with 2 C options	B	90	130	-	242	242	165	231	308	370	308	370
Distance between mounting holes	b	70	110	171	215	210	140	200	272	334	270	330
<b>Depth<sup>1)</sup> [mm]</b>												
Without option A/B	C	205	205	175	200	260	248	242	310	335	333	333
With option A/B	C	220	220	175	200	260	262	242	310	335	333	333
<b>Screw holes [mm]</b>												
	c	8.0	8.0	8.25	8.2	12	8	-	12	12	-	-
	d	ø11	ø11	ø12	ø12	ø19	12	-	ø19	ø19	-	-
	e	ø5.5	ø5.5	ø6.5	ø6.5	ø9	6.8	8.5	ø9.0	ø9.0	8.5	8.5
	f	9	9	6	9	9	7.9	15	9.8	9.8	17	17
<b>Maximum weight [kg]</b>												
		4.9	5.3	6.6	14	23	12	23.5	45	65	35	50

1) Depth of enclosure will vary with different options installed.

Table 7.31 Power Ratings, Weight, and Dimensions

## 7.9 dU/dt Testing

To avoid damage to motors without phase insulation paper or other insulation reinforcement designed for operation of the frequency converter, installation of a dU/dt filter or LC filter on the output of the frequency converter is recommended.

When a transistor in the inverter bridge switches, the voltage across the motor increases by a dU/dt ratio depending on:

- Motor inductance
- Motor cable (type, cross-section, length, screened, or unscreened)

The natural induction causes an overshoot voltage peak in the motor voltage before it stabilises. The level depends on the voltage in the DC-link.

Peak voltage on the motor terminals is caused by the switching of the IGBTs. The rise time and the peak voltage affects the service life of the motor. If the peak voltage is too high, motors without phase coil insulation can be adversely affected over time.

With short motor cables (a few metres), the rise time and peak voltage are lower. The rise time and peak voltage increase with cable length.

The frequency converter complies with IEC 60034-25 and IEC 60034-17 for motor design.

### 7.9.1 Peak Voltage on Motor

To obtain approximate values for cable lengths and voltages not mentioned below, use the following "Rules of Thumb":

1. Rise time increases/decreases proportionally with cable length.
2.  $U_{PEAK} = \text{DC link voltage} \times 1.9$   
(DC link voltage = Mains voltage  $\times$  1.35).
3.  $dU/dt = \frac{0.8 \times U_{PEAK}}{\text{Risetime}}$

Data is measured according to IEC 60034-17. Cable lengths are in metres.

#### 200–240 V (T2)

Cable length [m]	Mains voltage [V]	Rise time [µsec]	$U_{PEAK}$ [kV]	dU/dt [kV/µsec]
36	240	0.226	0.616	2.142
50	240	0.262	0.626	1.908
100	240	0.650	0.614	0.757
150	240	0.745	0.612	0.655

Table 7.32 Frequency Converter, P5K5, T2

Cable length [m]	Mains voltage [V]	Rise time [µsec]	$U_{PEAK}$ [kV]	dU/dt [kV/µsec]
5	230	0.13	0.510	3.090
50	230	0.23	0.590	2.034
100	230	0.54	0.580	0.865
150	230	0.66	0.560	0.674

Table 7.33 Frequency Converter, P7K5, T2

Cable length [m]		Rise time [µsec]	$U_{PEAK}$ [kV]	dU/dt [kV/µsec]
36	240	0.264	0.624	1.894
136	240	0.536	0.596	0.896
150	240	0.568	0.568	0.806

Table 7.34 Frequency Converter, P11K, T2

Cable length [m]	Mains voltage [V]	Rise time [µsec]	$U_{PEAK}$ [kV]	dU/dt [kV/µsec]
30	240	0.556	0.650	0.935
100	240	0.592	0.594	0.807
150	240	0.708	0.575	0.669

Table 7.35 Frequency Converter, P15K, T2

Cable length [m]	Mains voltage [V]	Rise time [µsec]	$U_{PEAK}$ [kV]	dU/dt [kV/µsec]
36	240	0.244	0.608	1.993
136	240	0.568	0.580	0.832
150	240	0.720	0.574	0.661

Table 7.36 Frequency Converter, P18K, T2

Cable length [m]	Mains voltage [V]	Rise time [µsec]	$U_{PEAK}$ [kV]	dU/dt [kV/µsec]
36	240	0.244	0.608	1.993
136	240	0.560	0.580	0.832
150	240	0.720	0.574	0.661

Table 7.37 Frequency Converter, P22K, T2

Cable length [m]	Mains voltage [V]	Rise time [µsec]	$U_{PEAK}$ [kV]	dU/dt [kV/µsec]
15	240	0.194	0.626	2.581
50	240	0.252	0.574	1.929
150	240	0.444	0.538	0.977

Table 7.38 Frequency Converter, P30K, T2

Cable length [m]	Mains voltage [V]	Rise time [µsec]	U <sub>PEAK</sub> [kV]	dU/dt [kV/µsec]
30	240	0.300	0.598	1.593
100	240	0.536	0.566	0.843
150	240	0.776	0.546	0.559

Table 7.39 Frequency Converter, P37K, T2

Cable length [m]	Mains voltage [V]	Rise time [µsec]	U <sub>PEAK</sub> [kV]	dU/dt [kV/µsec]
30	240	0.300	0.598	1.593
100	240	0.536	0.566	0.843
150	240	0.776	0.546	0.559

Table 7.40 Frequency Converter, P45K, T2

380–480 V (T4)

Cable length [m]	Mains voltage [V]	Rise time [µsec]	U <sub>PEAK</sub> [kV]	dU/dt [kV/µsec]
5	400	0.640	0.690	0.862
50	400	0.470	0.985	0.985
150	400	0.760	1.045	0.947

Table 7.41 Frequency Converter, P1K5, T4

Cable length [m]	Mains voltage [V]	Rise time [µsec]	U <sub>PEAK</sub> [kV]	dU/dt [kV/µsec]
5	400	0.172	0.890	4.156
50	400	0.310		2.564
150	400	0.370	1.190	1.770

Table 7.42 Frequency Converter, P4K0, T4

Cable length [m]	Mains voltage [V]	Rise time [µsec]	U <sub>PEAK</sub> [kV]	dU/dt [kV/µsec]
5	400	0.04755	0.739	8.035
50	400	0.207	1.040	4.548
150	400	0.6742	1.030	2.828

Table 7.43 Frequency Converter, P7K5, T4

Cable length [m]	Mains voltage [V]	Rise time [µsec]	U <sub>PEAK</sub> [kV]	dU/dt [kV/µsec]
15	400	0.408	0.718	1.402
100	400	0.364	1.050	2.376
150	400	0.400	0.980	2.000

Table 7.44 Frequency Converter, P11K, T4

Cable length [m]	Mains voltage [V]	Rise time [µsec]	U <sub>PEAK</sub> [kV]	dU/dt [kV/µsec]
36	400	0.422	1.060	2.014
100	400	0.464	0.900	1.616
150	400	0.896	1.000	0.915

Table 7.45 Frequency Converter, P15K, T4

Cable length [m]	Mains voltage [V]	Rise time [µsec]	U <sub>PEAK</sub> [kV]	dU/dt [kV/µsec]
36	400	0.344	1.040	2.442
100	400	1.000	1.190	0.950
150	400	1.400	1.040	0.596

Table 7.46 Frequency Converter, P18K, T4

Cable length [m]	Mains voltage [V]	Rise time [µsec]	U <sub>PEAK</sub> [kV]	dU/dt [kV/µsec]
36	400	0.232	0.950	3.534
100	400	0.410	0.980	1.927
150	400	0.430	0.970	1.860

Table 7.47 Frequency Converter, P22K, T4

Cable length [m]	Mains voltage [V]	Rise time [µsec]	U <sub>PEAK</sub> [kV]	dU/dt [kV/µsec]
15	400	0.271	1.000	3.100
100	400	0.440	1.000	1.818
150	400	0.520	0.990	1.510

Table 7.48 Frequency Converter, P30K, T4

Cable length [m]	Mains voltage [V]	Rise time [µsec]	U <sub>PEAK</sub> [kV]	dU/dt [kV/µsec]
5	480	0.270	1.276	3.781
50	480	0.435	1.184	2.177
100	480	0.840	1.188	1.131
150	480	0.940	1.212	1.031

Table 7.49 Frequency Converter, P37K, T4

Cable length [m]	Mains voltage [V]	Rise time [µsec]	U <sub>PEAK</sub> [kV]	dU/dt [kV/µsec]
36	400	0.254	1.056	3.326
50	400	0.465	1.048	1.803
100	400	0.815	1.032	1.013
150	400	0.890	1.016	0.913

Table 7.50 Frequency Converter, P45K, T4

Cable length [m]	Mains voltage [V]	Rise time [μsec]	U <sub>PEAK</sub> [kV]	dU/dt [kV/μsec]
10	400	0.350	0.932	2.130

Table 7.51 Frequency Converter, P55K, T4

Cable length [m]	Mains voltage [V]	Rise time [μsec]	U <sub>PEAK</sub> [kV]	dU/dt [kV/μsec]
5	480	0.371	1.170	2.466

Table 7.52 Frequency Converter, P75K, T4

Cable length [m]	Mains voltage [V]	Rise time [μsec]	U <sub>PEAK</sub> [kV]	dU/dt [kV/μsec]
5	400	0.364	1.030	2.264

Table 7.53 Frequency Converter, P90K, T4

525–600V (T6)

Cable length [m]	Mains voltage [V]	Rise time [μsec]	U <sub>PEAK</sub> [kV]	dU/dt [kV/μsec]
36	600	0.304	1.560	4.105
50	600	0.300	1.550	4.133
100	600	0.536	1.640	2.448
150	600	0.576	1.640	2.278

Table 7.54 Frequency Converter, P11K, T6

Cable length [m]	Mains voltage [V]	Rise time [μsec]	U <sub>PEAK</sub> [kV]	dU/dt [kV/μsec]
36	600	0.084	1.560	7.962
50	600	0.120	1.540	5.467
100	600	0.165	1.472	3.976
150	600	0.190	1.530	3.432

Table 7.55 Frequency Converter, P22K, T6

Cable length [m]	Mains voltage [V]	Rise time [μsec]	U <sub>PEAK</sub> [kV]	dU/dt [kV/μsec]
15	600	0.276	1.184	4.290

Table 7.56 Frequency Converter, P55K, T6

525–690V (T7)

Cable length [m]	Mains voltage [V]	Rise time [μsec]	U <sub>PEAK</sub> [kV]	dU/dt [kV/μsec]
80	690	0.580	1.728	2.369
130	690	0.930	1.824	1.569
180	690	0.925	1.818	1.570

Table 7.57 Frequency Converter, P7K5, T7

Cable length [m]	Mains voltage [V]	Rise time [μsec]	U <sub>PEAK</sub> [kV]	dU/dt [kV/μsec]
5	690	0.250	1.440	4.608
105	690	0.570	1.800	2.526
180	690	0.982	1.840	1.499

Table 7.58 Frequency Converter, P45K, T7

Cable length [m]	Mains voltage [V]	Rise time [μsec]	U <sub>PEAK</sub> [kV]	dU/dt [kV/μsec]
6	690	0.238	1.416	4.739
50	690	0.358	1.764	3.922
150	690	0.465	1.872	3.252

Table 7.59 Frequency Converter, P55K, T7

7.10 Acoustic Noise Ratings

Enclosure size	50% fan speed [dBA]	Full fan speed [dBA]
A1	51	60
A2	51	60
A3	51	60
A4	51	60
A5	54	63
B1	61	67
B2	58	70
B4	52	62
C1	52	62
C2	55	65
C4	56	71
D3h	58	71

Table 7.60 Acoustic Noise Ratings

Values are measured 1 m from the unit.



## 7.11 Selected Options

### 7.11.1 VLT® General Purpose I/O Module MCB 101

MCB 101 is used for extension of digital and analog inputs and outputs.

Fit MCB 101 into slot B of the frequency converter.

Contents:

- MCB 101 option module
- Extended fixture for LCP

### 7.11.2 VLT® Relay Card MCB 105

The relay option MCB 105 includes 3 pieces of SPDT contacts and must be fitted into option slot B.

#### Electrical Data

Maximum terminal load (AC-1) <sup>1)</sup> (resistive load)	240 V AC 2 A
Maximum terminal load (AC-15) <sup>1)</sup> (inductive load @ cosφ 0.4)	240 V AC 0.2 A
Maximum terminal load (DC-1) <sup>1)</sup> (resistive load)	24 V DC 1 A
Maximum terminal load (DC-13) <sup>1)</sup> (inductive load)	24 V DC 0.1 A
Minimum terminal load (DC)	5 V 10 mA
Maximum switching rate at rated load/min load	6 minimum <sup>-1</sup> /20 s <sup>-1</sup>

1) IEC 947 part 4 and 5

When the relay option kit is ordered separately, the kit includes

- Relay module MCB 105
- Enlarged LCP fixture and enlarged terminal cover
- Label for covering access to switches S201, S202 and S801
- Cable strips for fastening cables to relay module

- Terminal cover

MCB 101	FC Series
General Purpose I/O	B slot
SW. ver. XX.XX	Code No. 130BXXXX

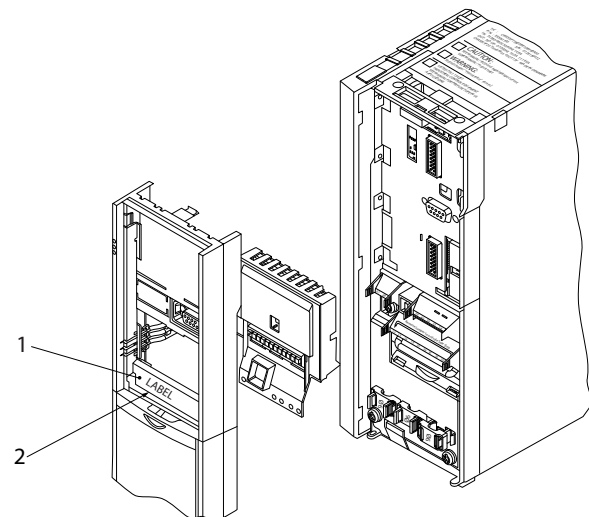
  

COM	DIN	DIN7	DIN8	DIN9	GND(1)	DOUT3	DOUT4	AOUT2	24V	GND(2)	AIN3	AIN4
X30/	1	2	3	4	5	6	7	8	9	10	11	12

130BA208.10

Illustration 7.2 MCB 101 Option

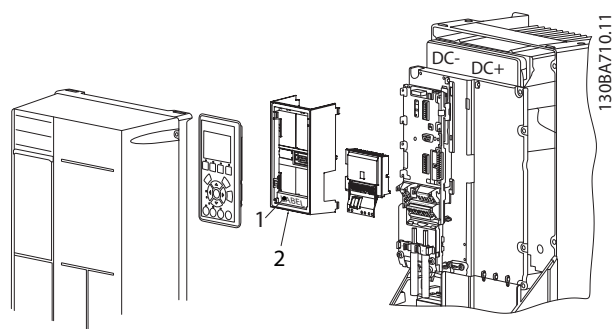
7



130BA709.11

1	<b>WARNING !</b> The label MUST be placed on the LCP frame as shown (UL approved).
2	Relay card

Illustration 7.3 Enclosure Sizes A2-A3-B3



1	<b>WARNING!</b> The label MUST be placed on the LCP frame as shown (UL approved).
2	Relay card

Illustration 7.4 Enclosure Sizes A5-B1-B2-B4-C1-C2-C3-C4

**NOTICE**

To access RS485 termination, switch S801 or current/voltage switches S201/S202, dismount the relay card (see *Illustration 7.3* and *Illustration 7.4*, position 2).

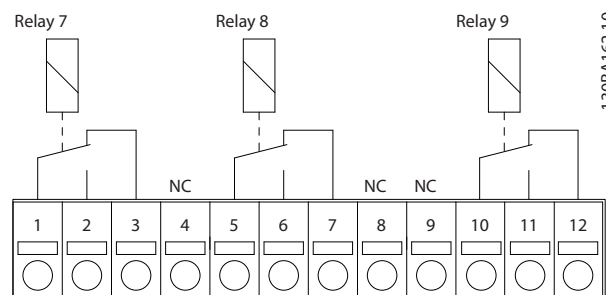


Illustration 7.6 Relays

7



Warning Dual Supply

130BE040.10

Illustration 7.5 Warning Label Placed on Option

How to add the Relay card MCB 105 option:

1. Disconnect power to the frequency converter.
2. Disconnect power to the live part connections on relay terminals.
3. Remove the LCP, the terminal cover, and the LCP fixture from the frequency converter.
4. Fit the MCB 105 option in slot B.
5. Connect the control cables and fasten the cables with the enclosed cable strips.
6. Make sure the length of the stripped wire is correct (see *Illustration 7.7*).
7. Do not mix live parts (high voltage) with control signals (PELV).
8. Fit the enlarged LCP fixture and enlarged terminal cover.
9. Replace the LCP.
10. Connect power to the frequency converter.
11. Select the relay functions in *5-40 Function Relay* [6-8], *5-41 On Delay, Relay* [6-8] and *5-42 Off Delay, Relay* [6-8].

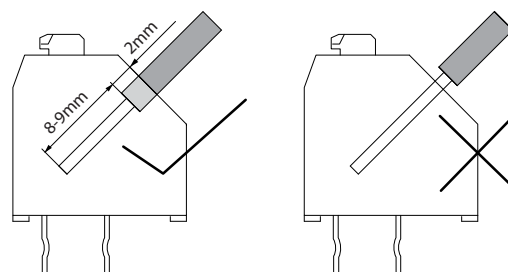
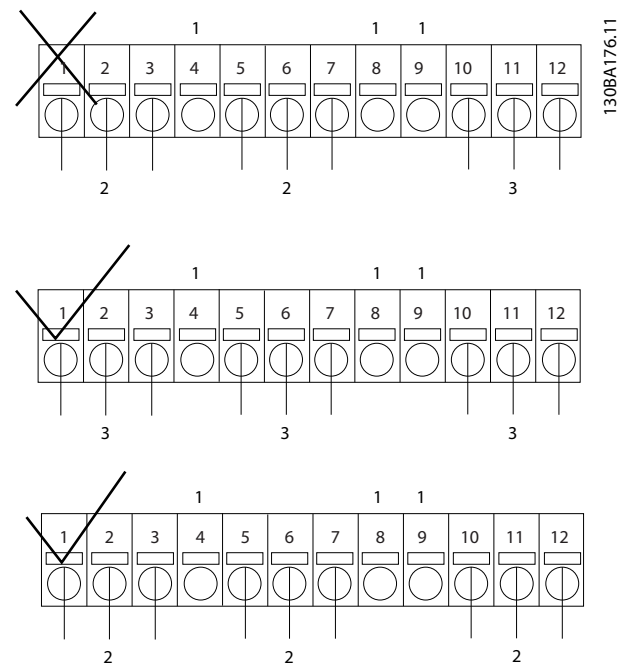


Illustration 7.7 Correct Wire Inserting

**NOTICE**

Array [6] is relay 7, array [7] is relay 8, and array [8] is relay 9



130BA176.11

1	NC
2	Live part
3	PELV

Illustration 7.8 Correct Relay Wiring

**NOTICE**

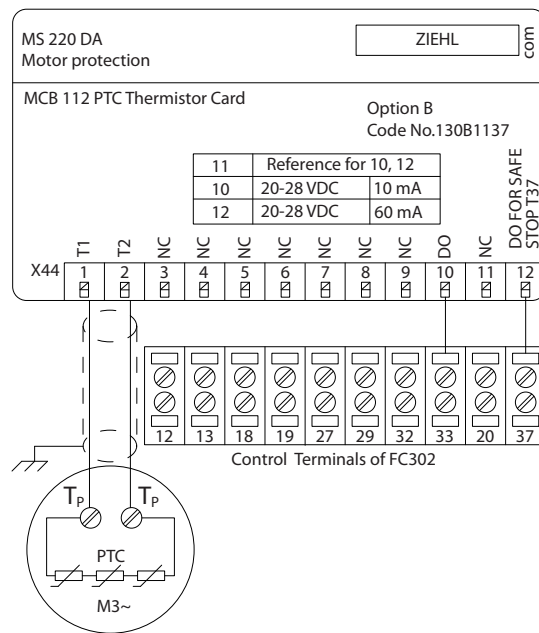
Do not combine 24/48 V systems with high-voltage systems.

7.11.3 VLT<sup>®</sup> PTC Thermistor Card MCB 112

The MCB 112 option makes it possible to monitor the temperature of an electrical motor through a galvanically isolated PTC thermistor input. It is a B option for frequency converters with STO.

For different application possibilities, see *chapter 4 Application Examples*.

X44/1 and X44/2 are the thermistor inputs. X44/12 enables STO of the frequency converter (T37), if the thermistor values make it necessary, and X44/10 informs the frequency converter that a request for STO came from the MCB 112 to ensure suitable alarm handling. One of the digital input parameters (or a digital input of a mounted option) must be set to [80] *PTC Card 1* to use the information from X44/10. Configure 5-19 *Terminal 37 Digital Input* to the desired STO functionality (default is safe stop alarm).



130BA638.10

Illustration 7.9 Installation of MCB 112

ATEX Certification with FC 102, FC 103, FC 202, and FC 302

The MCB 112 has been certified for ATEX, which means that the frequency converter with the MCB 112 can be used with motors in potentially explosive atmospheres. See the *VLT<sup>®</sup> PTC Thermistor Card MCB 112 Operating Instructions* for more information.



Illustration 7.10 ATmosphère EXplosive (ATEX)

**Electrical Data**

Resistor connection

PTC compliant with DIN 44081 and DIN 44082

Number	1..6 resistors in series
Shut-off value	3.3 Ω ... 3.65 Ω ... 3.85 Ω
Reset value	1.7 Ω ... 1.8 Ω ... 1.95 Ω
Trigger tolerance	± 6 °C
Collective resistance of the sensor loop	< 1.65 Ω
Terminal voltage	≤ 2.5 V for R ≤ 3.65 Ω, ≤ 9 V for R = ∞
Sensor current	≤ 1 mA
Short-circuit	20 Ω ≤ R ≤ 40 Ω
Power consumption	60 mA

Testing conditions

EN 60 947-8

Measurement voltage surge resistance	6000 V
Overvoltage category	III
Pollution degree	2
Measurement isolation voltage Vbis	690 V
Reliable galvanic isolation until Vi	500 V
Rated ambient temperature range	-20 °C to +60 °C EN 60068-2-1 dry heat
Moisture	5-95%, no condensation permissible
Vibration resistance	10 to 1000 Hz 1.14 g
Shock resistance	50 g

Safety system values

EN 61508 for Tu=75 °C ongoing

SIL	2 for maintenance cycle of 2 years 1 for maintenance cycle of 3 years
HFT	0
PFD (for yearly functional test)	4.10x10 <sup>-3</sup>
SFF	78%
λ <sub>s</sub> + λ <sub>DD</sub>	8494 FIT
λ <sub>DU</sub>	934 FIT
Ordering number 130B1137	

7

### 7.11.4 VLT® Extended Relay Card MCB 113

The MCB 113 extends the I/O of the frequency converter by 7 digital inputs, 2 analog outputs, and 4 SPDT relays. The extended I/O increases flexibility and enables compliance with the German NAMUR NE37 recommendations.

The MCB 113 is a standard C1 option and is automatically detected after mounting.

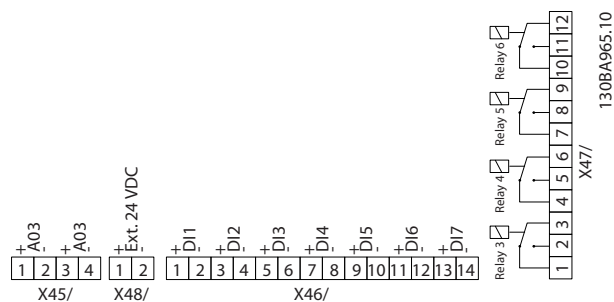


Illustration 7.11 Electrical Connections of MCB 113

To ensure galvanic isolation between the frequency converter and the option card, connect MCB 113 to an external 24 V on X48. When galvanic isolation is not required, the option card can be supplied through internal 24 V from the frequency converter.

#### Electrical Data

##### Relays

Numbers	4 SPDT
Load at 250 V AC/30 V DC	8 A
Load at 250 V AC/30 V DC with $\cos\phi = 0.4$	3.5 A
Over voltage category (contact-earth)	III
Over voltage category (contact-contact)	II
Combination of 250 V and 24 V signals	Possible with one unused relay between
Maximum throughput delay	10 ms
Isolated from ground/chassis for use on IT mains systems	

##### Digital Inputs

Numbers	7
Range	0–24 V
Mode	PNP/NPN
Input impedance	4 kW
Low trigger level	6.4 V
High trigger level	17 V
Maximum throughput delay	10 ms

##### Analog outputs

Numbers	2
Range	0/4 -20 mA
Resolution	11 bit
Linearity	<0.2%

### NOTICE

To connect both 24 V signals and high-voltage signals in the relays, ensure that there is one unused relay between the 24 V signal and the high-voltage signal.

To set up MCB 113, use parameter groups:

- 5-1\* Digital input
- 6-7\* Analog output 3
- 6-8\* Analog output 4
- 14-8\* Options
- 5-4\* Relays
- 16-6\* Inputs and outputs

### NOTICE

In parameter group 5-4\* Relay,

- Array [2] is relay 3.
- Array [3] is relay 4.
- Array [4] is relay 5.
- Array [5] is relay 6.

### 7.11.5 VLT<sup>®</sup> Sensor Input Option MCB 114

The sensor input option card MCB 114 can be used in the following cases:

- Sensor input for temperature transmitters PT100 and PT1000 for monitoring bearing temperatures.
- As general extension of analog inputs with one additional input for multi-zone control or differential pressure measurements.
- Support extended PID controllers with I/Os for set point, transmitter/sensor inputs.

Typical motors, designed with temperature sensors to protect bearings from being overloaded, are fitted with 3 PT100/1000 temperature sensors; 1 in front, 1 in the back-end bearing, and 1 in the motor windings. The VLT<sup>®</sup> Sensor Input Option MCB 114 supports 2- or 3-wire sensors with individual temperature limits for under-/overtemperature. An auto-detection of sensor type PT100 or PT1000 takes place at power-up.

If the measured temperature is either below the specified low limit, or above the specified high limit, the option generates an alarm. The individual measured temperature on each sensor input can be read out in the display or by readout parameters. If an alarm occurs, the relays or digital outputs can be programmed to be active high by selecting [21] *Thermal Warning* in parameter group 5-\*\* *Digital In/Out*.

A fault condition has a common warning/alarm number associated with it, which is *Alarm/Warning 20, Temp. input error*. Any present output can be programmed to be active in case the warning or alarm appears.

#### 7.11.5.1 Electrical and Mechanical Specifications

##### Analog Input

Number of analog inputs	1
Format	0–20 mA or 4–20 mA
Wires	2
Input impedance	<200 Ω
Sample rate	1 kHz
3rd order filter	100 Hz at 3 dB

The option is able to supply the analog sensor with 24 V DC (terminal 1).

##### Temperature Sensor Input

Number of analog inputs supporting PT100/1000	3
Signal type	PT100/1000
Connection	PT 100 2 or 3 wire/PT1000 2 or 3 wire
Frequency PT100 and PT1000 input	1 Hz for each channel
Resolution	10 bit
Temperature range	-50–204 °C -58–399 °F

##### Galvanic Isolation

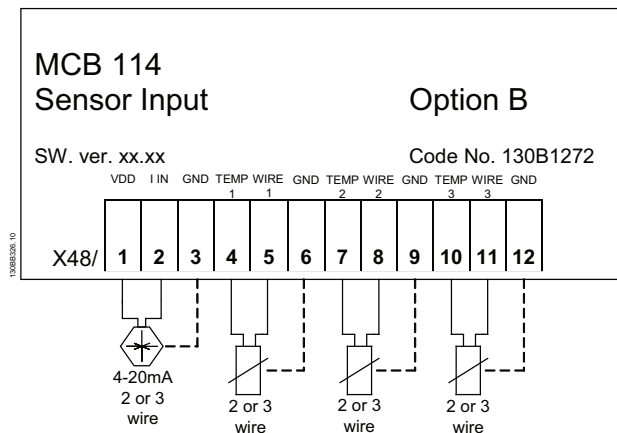
The sensors to be connected are expected to be galvanically isolated from the mains voltage level

IEC 61800-5-1 and UL508C

##### Cabling

Maximum signal cable length	500 m
-----------------------------	-------

### 7.11.5.2 Electrical Wiring



Terminal	Name	Function
1	VDD	24 V DC to supply 4–20 mA sensor
2	I in	4–20 mA input
3	GND	Analog input GND
4, 7, 10	Temp 1, 2, 3	Temperature input
5, 8, 11	Wire 1, 2, 3	3 <sup>rd</sup> wire input if 3 wire sensors are used
6, 9, 12	GND	Temperature input GND

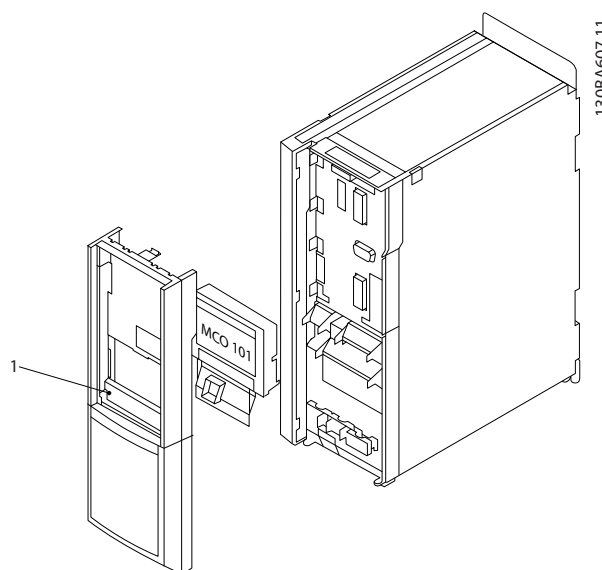
Illustration 7.12 MCB 114 Electrical Wiring

### 7.11.6 VLT<sup>®</sup> Extended Cascade Controller MCO 101

The MCO 101 option includes 3 pieces of change-over contacts and can be fitted into option slot B.

Max terminal load (AC)	240 V AC 2 A
Max terminal load (DC)	24 V DC 1 A
Min terminal load (DC)	5 V 10 mA
Max switching rate at rated load/min load	6 min <sup>-1</sup> /20 s <sup>-1</sup>

Table 7.61 MCO 101 Electrical Data



1 Dismount MCO 101 option to access RS485 termination (S801) or current/voltage switches (S201, S202)

Illustration 7.13 Mounting of B Option

How to add the MCO 101 option:

1. Disconnect power to the frequency converter.
2. Disconnect power to the live part connections on relay terminals.
3. Remove the LCP, the terminal cover and the cradle from the FC 202.
4. Fit the MCO 101 option in slot B.
5. Connect the control cables and relieve the cables by the enclosed cable strips.
6. Fit the extended cradle and terminal cover.
7. Remount the LCP.
8. Connect power to the frequency converter.

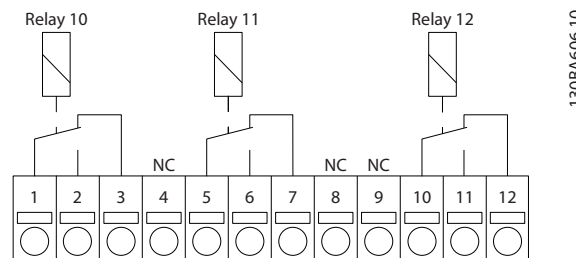
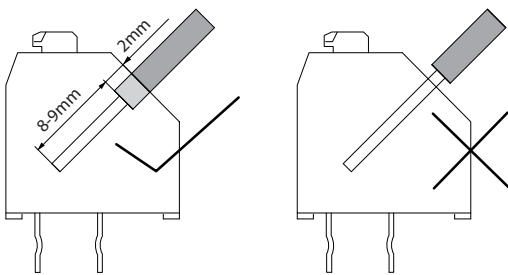


Illustration 7.14 Usage of Connections



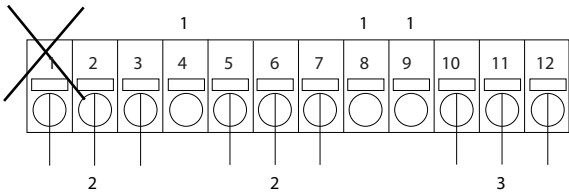
130BA177.10

Illustration 7.15 Mounting of Cables

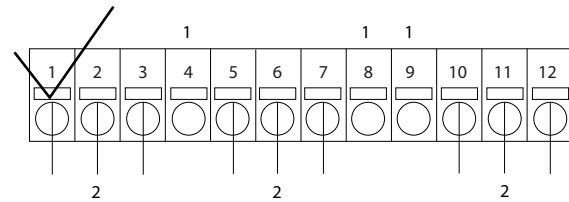
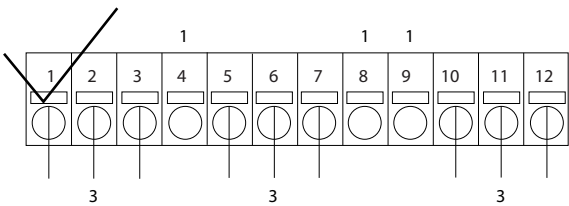
**⚠ WARNING**

Do not combine low voltage parts and PELV systems (see *Illustration 7.16*).

7



130BA176.11



1	NC
2	Live part
3	PELV

Illustration 7.16 Incorrect and Correct Relay Wiring



### 7.11.7 VLT® Advanced Cascade Controller MCO 102

The VLT advanced cascade control card MCO 102 option is exclusively intended for use in option slot C1. The mounting position of C1 options is shown in *Illustration 7.17*.

Max terminal load (AC)	240 V AC 2 A
Max terminal load (DC)	24 V DC 1 A
Min terminal load (DC)	5 V 10 mA
Max switching rate at rated load/minimum load	6 min <sup>-1</sup> /20 s <sup>-1</sup>

Table 7.62 Electrical Data, MCO 102

#### Tools required

Some items are needed for the installation of a C option mounting kit (depending on the enclosure):

Type	Description	Ordering number
<b>Options</b>		
MCF 105	Mounting Kit frame size A2 and A3 (40 mm for one C Option)	130B7530
MCF 105	Mounting Kit Frame size A5	130B7532
MCF 105	Mounting Kit Frame size B, C, D, E, F1 and F3 (Except B3)	130B7533
MCF 105	Mounting Kit frame size B3 (40 mm for one C Option)	130B1413
<b>Accessory bag</b>		
MCO 102	Accessory Bag	130B0152

Table 7.63 Ordering Numbers for Mounting Kits and Accessory Bag

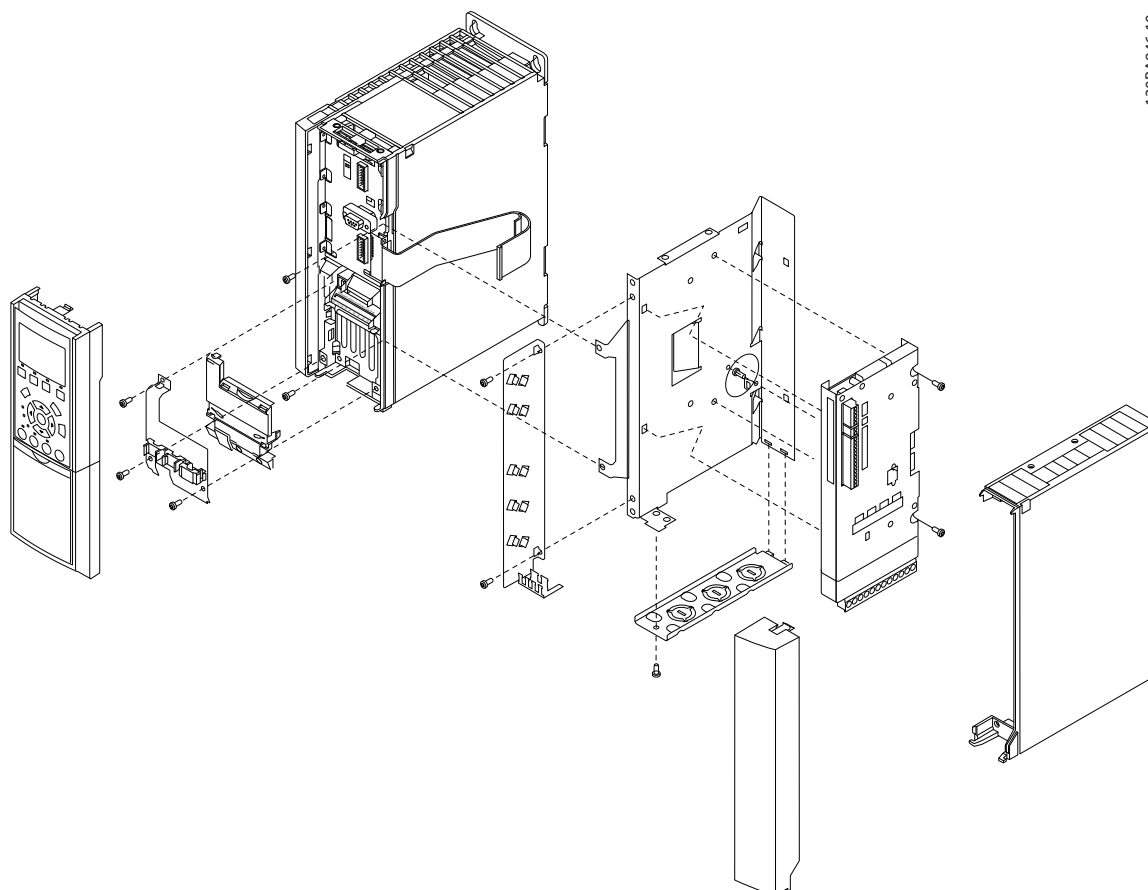


Illustration 7.17 Enclosure A2, A3 (and B3) 40 mm (only one C option)

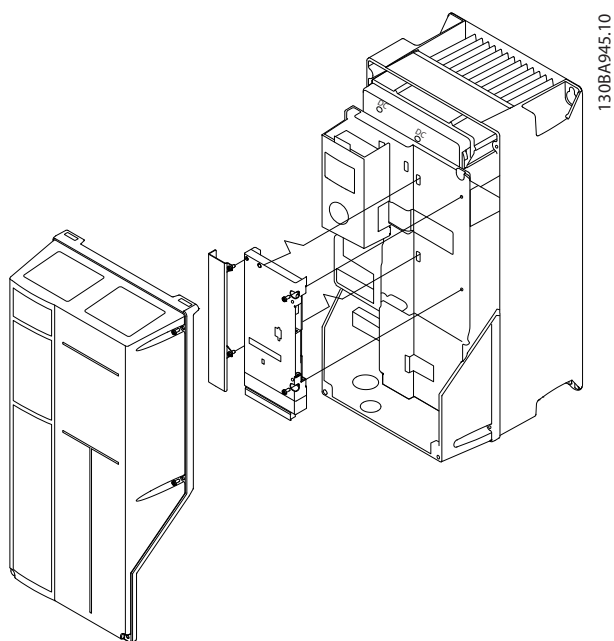


Illustration 7.18 Enclosures B (except B3) and C

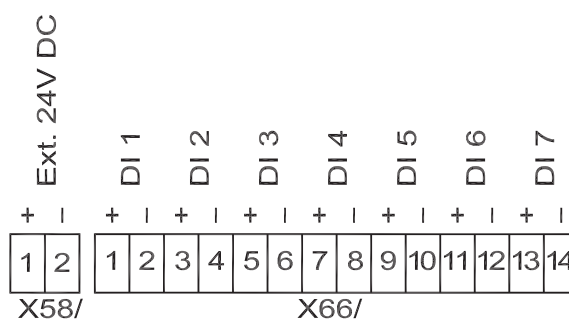


Illustration 7.20 Advanced Cascade Controller MCO 102 Terminal Connections to the 7 Digital Inputs and Access to the Internal 24 V DC

How to add the MCO 102 option

1. Disconnect power.
2. Disconnect power to the live part connections on relay terminals.
3. Remove the LCP, the terminal cover and the cradle from the FC 202.
4. Fit the MCO 102 option in slot C1.
5. Connect the control cables and relieve the cables by the enclosed cable strips.
6. Fit the extended cradle and terminal cover.
7. Remount the LCP.
8. Connect power to the frequency converter.

Wiring the Terminals

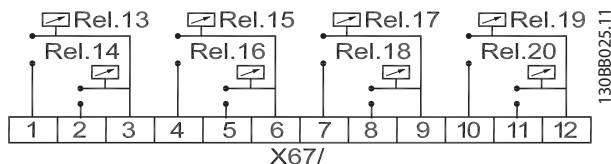


Illustration 7.19 Advanced Cascade Controller MCO 102 Terminal Connections, 8 Relays

## 8 Appendix - Selected Drawings

### 8.1 Mains Connection Drawings (3-phases)

This collection of drawings is intended to aid planning for access, in the design phase.

Refer to the *operating instructions* for installation procedures including:

- Safety requirements.
- Step-by-step installation procedures.
- Alternative configurations.
- Additional drawings.

Mains connection for enclosures A1, A2 and A3:

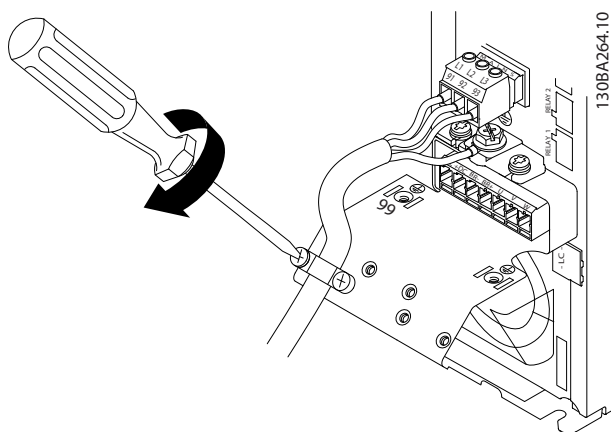


Illustration 8.1 Support Bracket

Mains connection for enclosures A4/A5

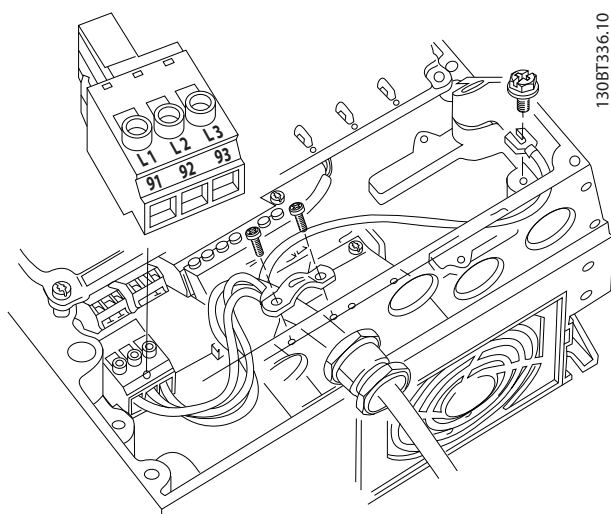


Illustration 8.2 Mains and Grounding without Disconnect

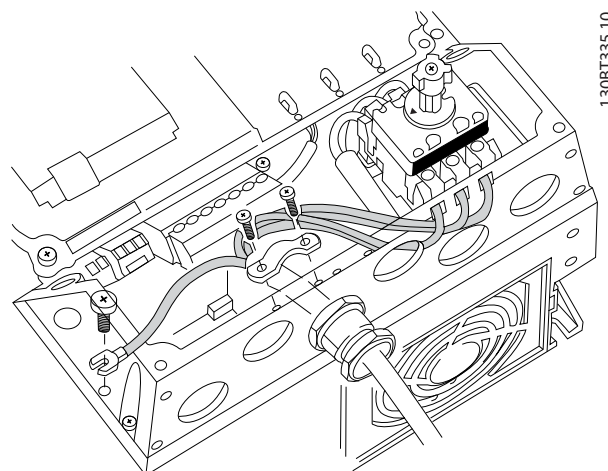


Illustration 8.3 Mains and Grounding with Disconnect (for S2 variants in enclosure size B2, the extra terminal block must be used for mains connection.)

When disconnect is used (enclosures A4/A5), mount the PE on the left side of the frequency converter.

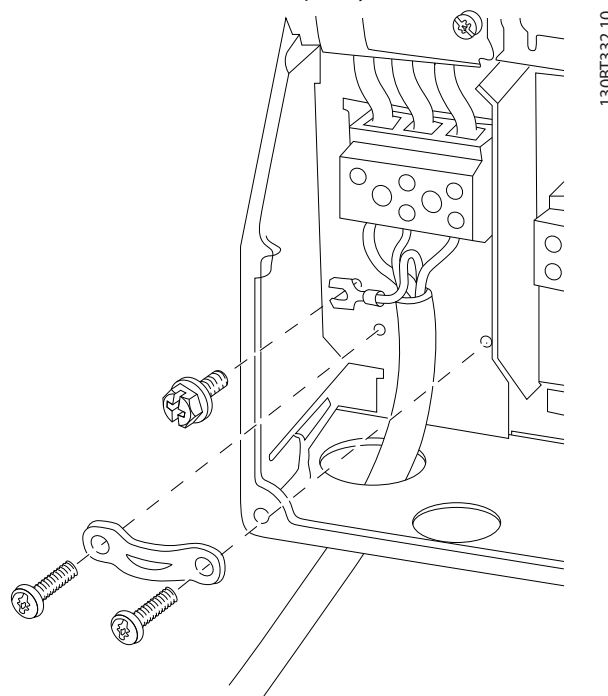


Illustration 8.4 Mains Connection Enclosures B1 and B2

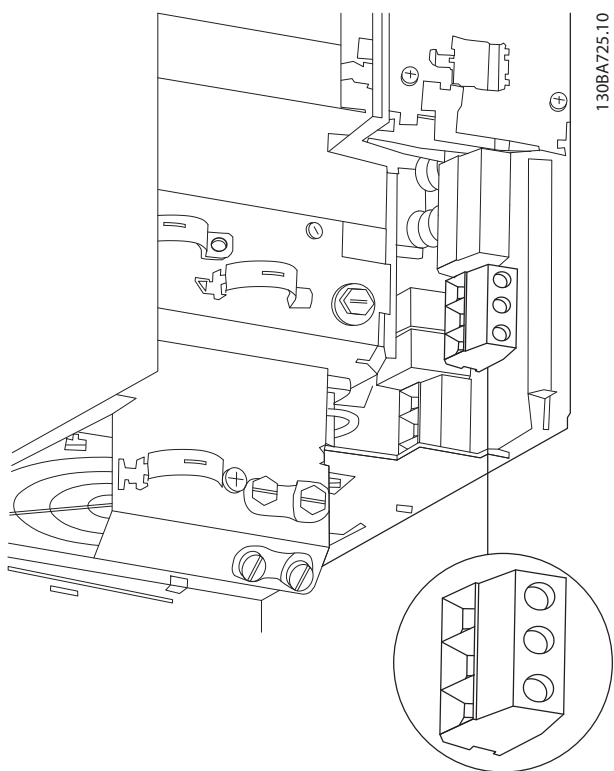


Illustration 8.5 Mains Connection Enclosure B3

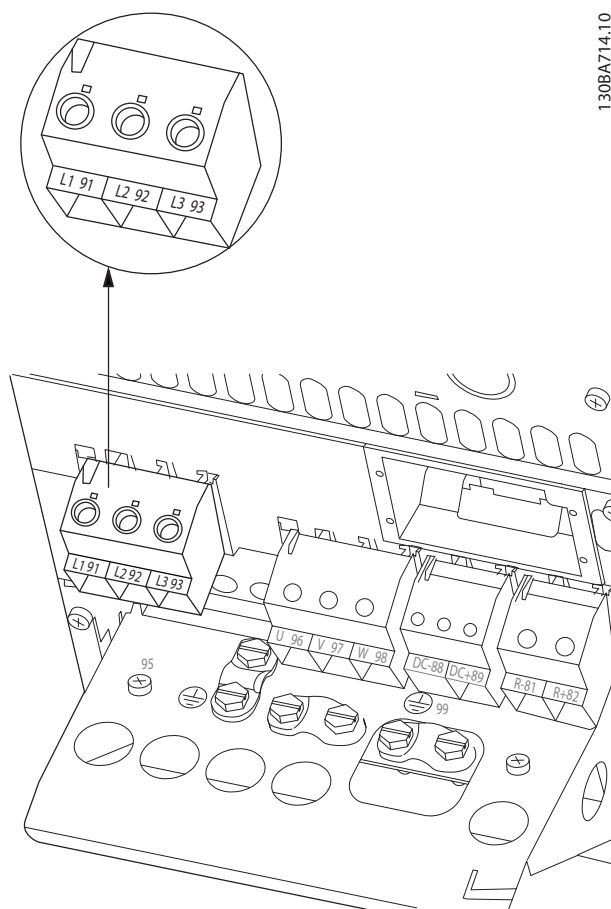


Illustration 8.6 Mains Connection Enclosure B4

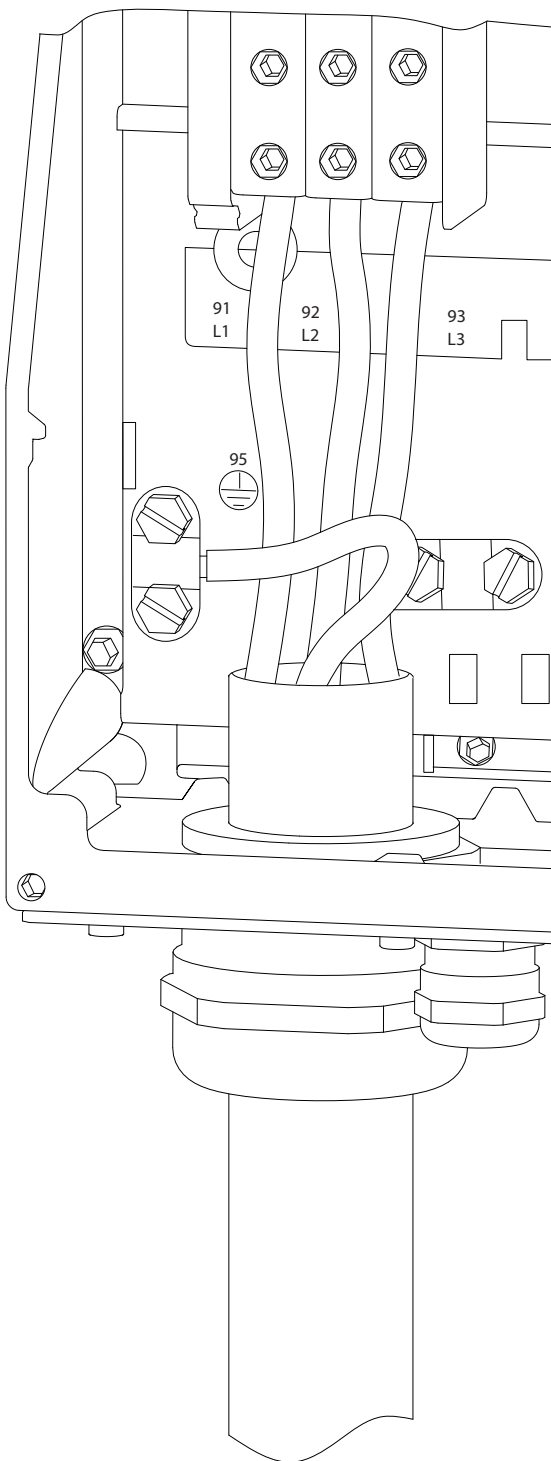


Illustration 8.7 Mains Connection Enclosures C1 and C2 (IP21/  
NEMA Type 1 and IP55/66/NEMA Type 12).

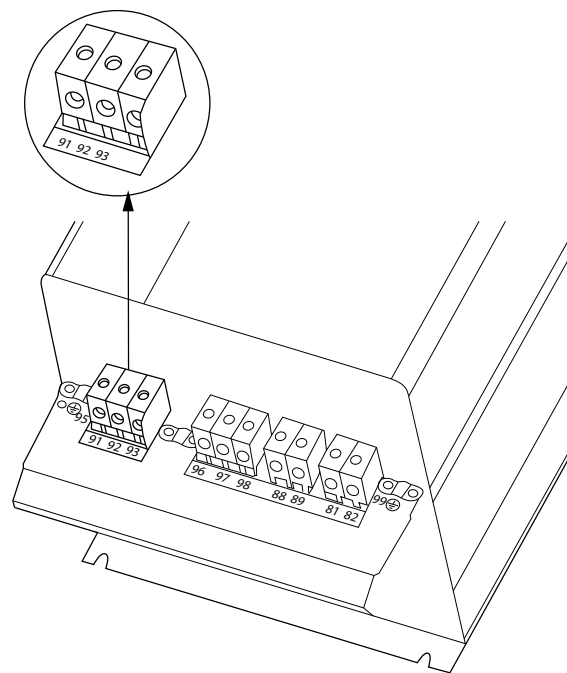


Illustration 8.8 Mains Connection Enclosures C3 (IP20).

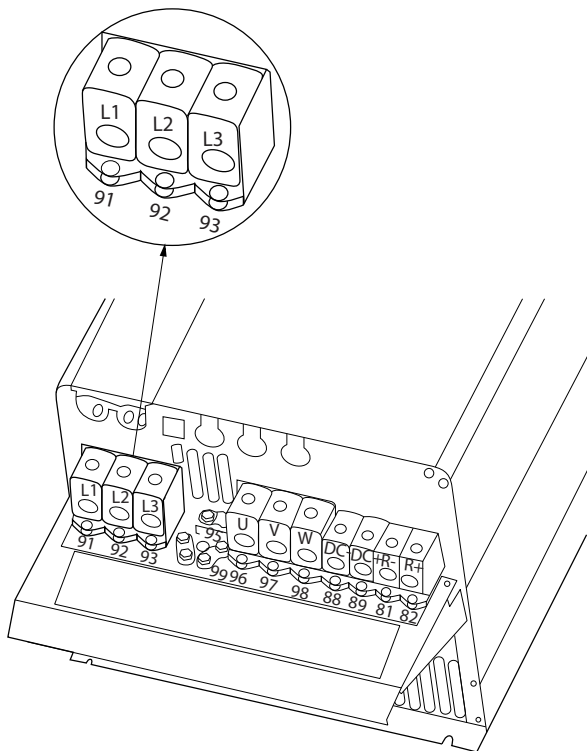


Illustration 8.9 Mains Connection Enclosures C4 (IP20).

## 8.2 Motor Connection Drawings

### Motor connection

This collection of drawings is intended to aid planning for access in the design phase.

Refer to the *operating instructions* for installation procedures including:

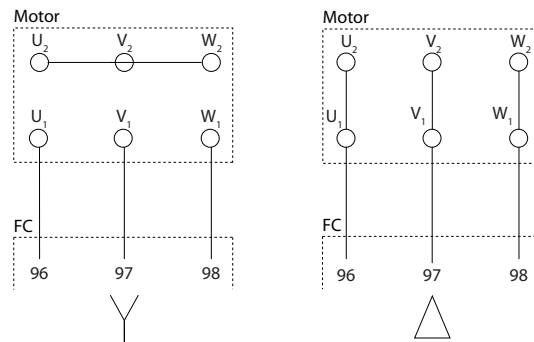
- Safety requirements.
- Step-by-step installation procedures.
- Terminal descriptions.
- Alternative configurations.
- Additional drawings.

Terminal number	96	97	98	99	
	U	V	W	PE <sup>1)</sup>	Motor voltage 0–100% of mains voltage. 3 wires out of motor
	U1	V1	W1	PE <sup>1)</sup>	Delta-connected
	W2	U2	V2		6 wires out of motor
	U1	V1	W1	PE <sup>1)</sup>	Star-connected U2, V2, W2 U2, V2 and W2 to be interconnected separately.

Table 8.1 Terminal Descriptions

1) Protected Ground Connection

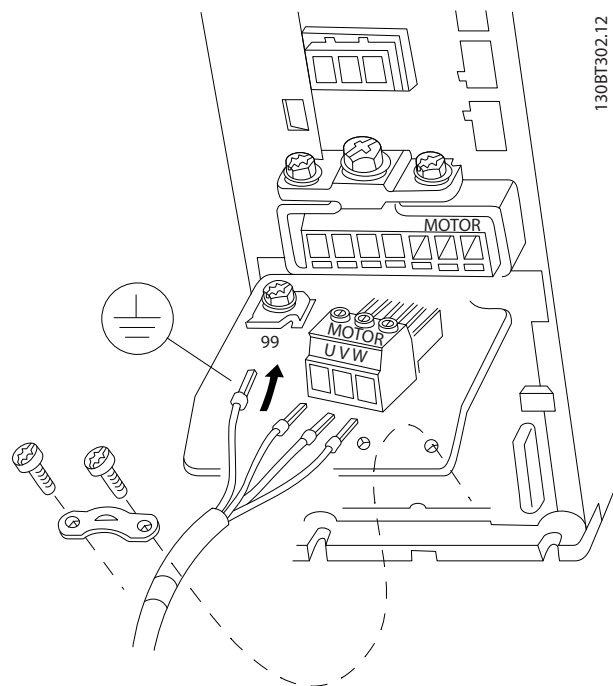
130BA719.10



175ZA114.11

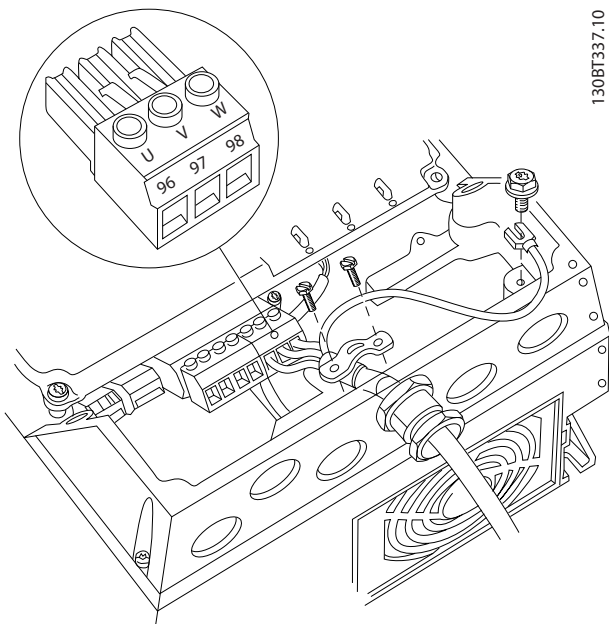
Illustration 8.10 Star and Delta Connections

All types of 3-phase asynchronous standard motors can be connected to the frequency converter. Normally, small motors are star-connected (230/400 V, Y). Large motors are normally delta-connected (400/690 V, Δ). Refer to the motor name plate for correct connection mode and voltage.



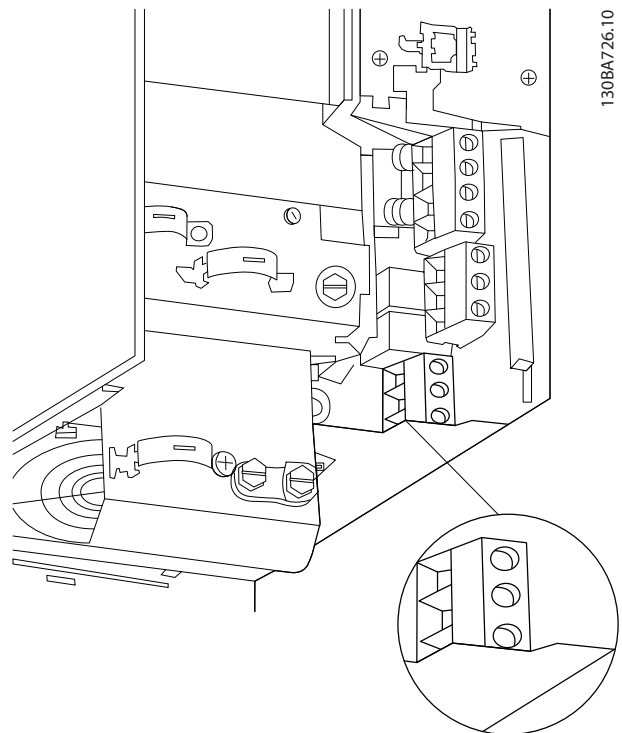
130BT302.12

Illustration 8.11 Motor Connection for Enclosures A1, A2 and A3



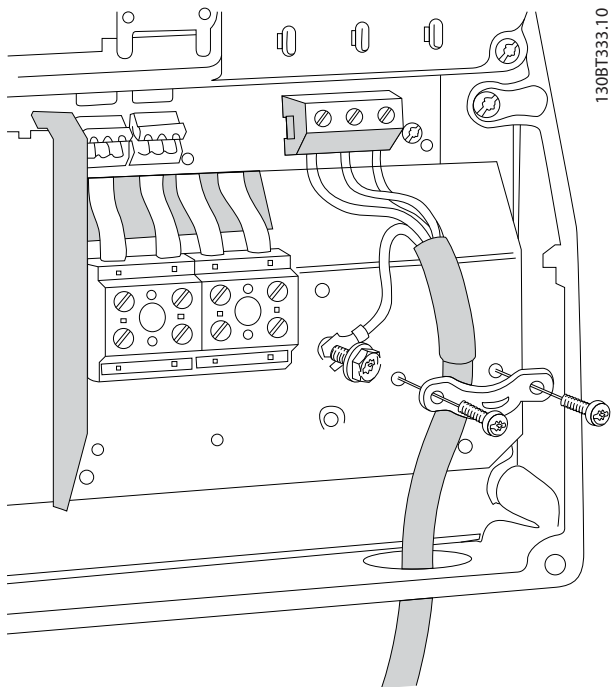
130BT337.10

Illustration 8.12 Motor Connection for Enclosures A4/A5



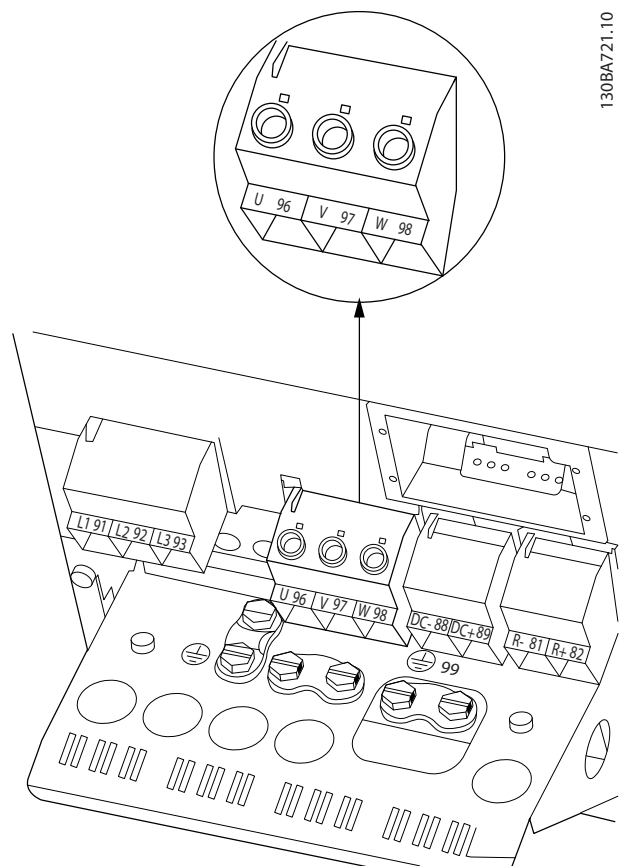
130BA726.10

Illustration 8.14 Motor Connection for Enclosure B3



130BT333.10

Illustration 8.13 Motor Connection for Enclosures B1 and B2



130BA721.10

Illustration 8.15 Motor Connection for Enclosure B4

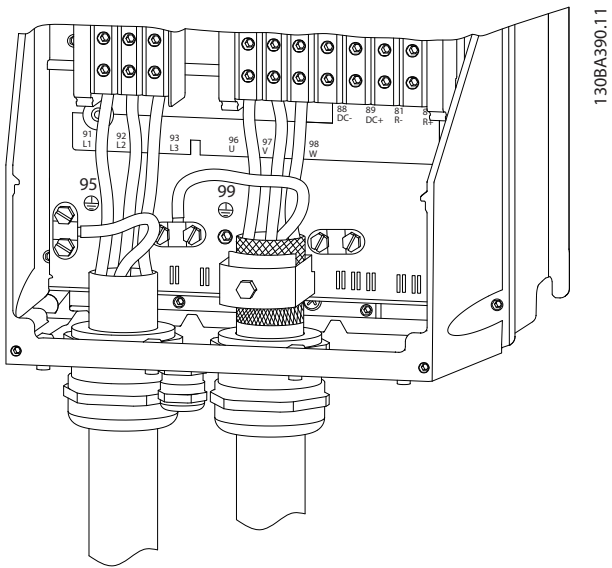


Illustration 8.16 Motor Connection Enclosures C1 and C2 (IP21/NEMA Type 1 and IP55/66/NEMA Type 12)

### 8.3 Relay Terminal Drawings

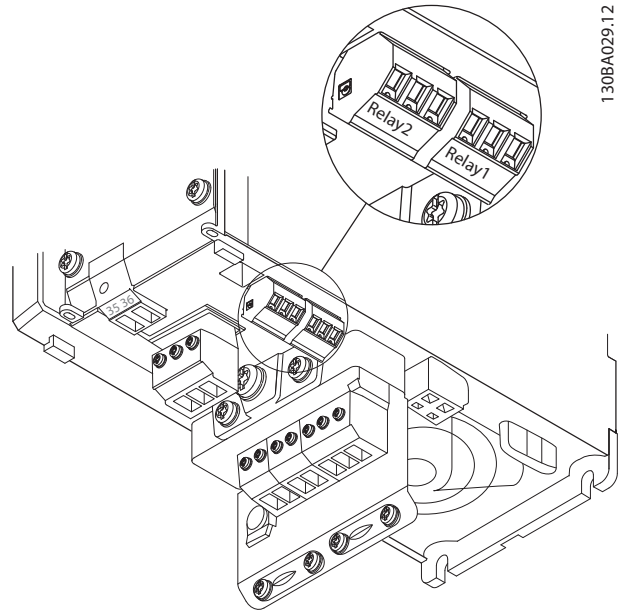


Illustration 8.18 Terminals for Relay Connection (Enclosure Sizes A1, A2 and A3).

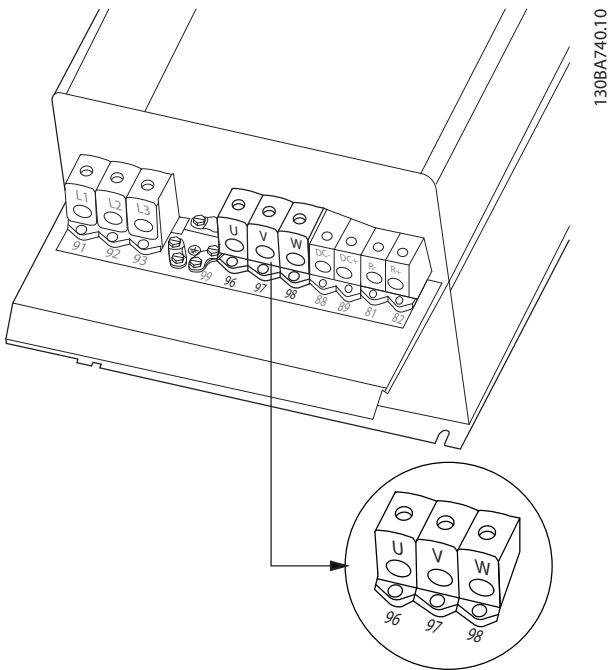


Illustration 8.17 Motor Connection for Enclosures C3 and C4

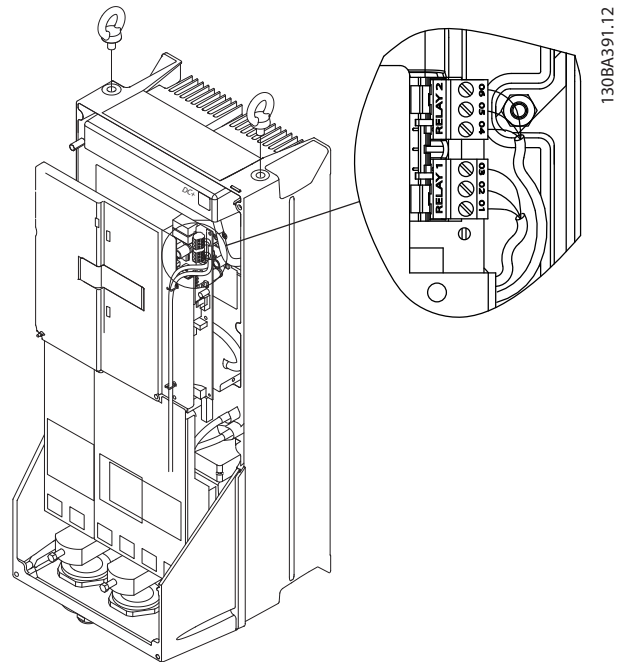
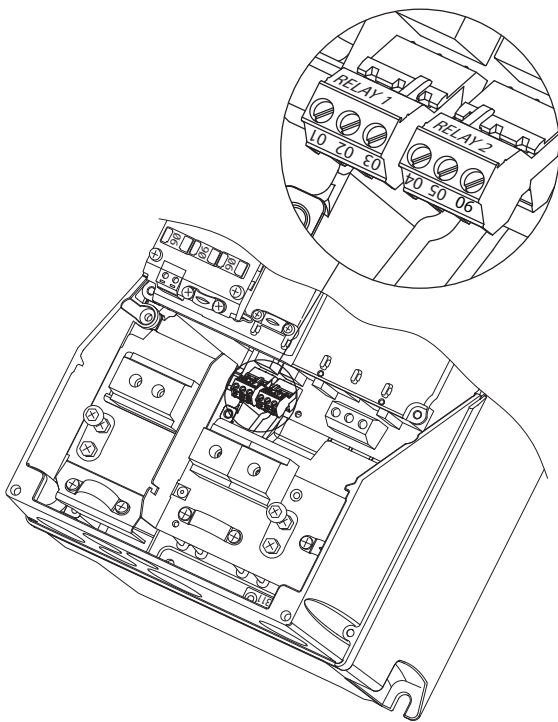


Illustration 8.19 Terminals for Relay Connection (Enclosure Sizes C1 and C2).

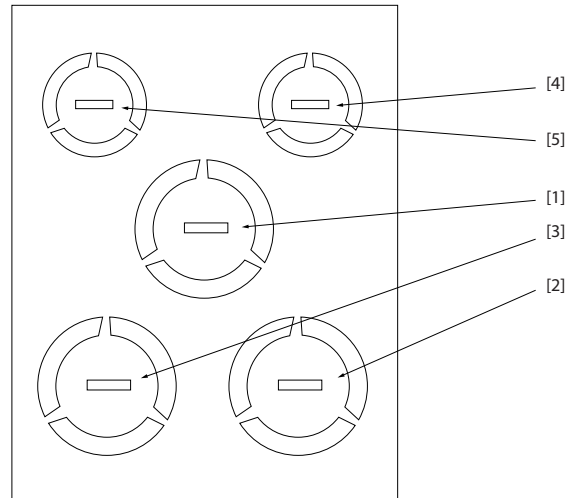




130BA215:10

Illustration 8.20 Terminals for Relay Connection (Enclosure Sizes A5, B1 and B2).

### 8.4 Cable Entry Holes

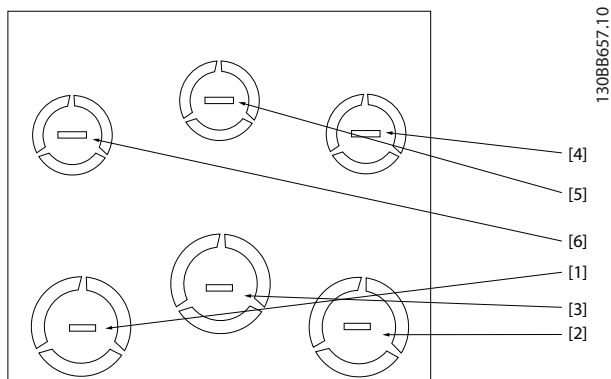


130BB656:10

Hole number and recommended use	Dimensions <sup>1)</sup>		Nearest metric
	UL [in]	[mm]	
1 Mains	3/4	28.4	M25
2 Motor	3/4	28.4	M25
3 Brake/load sharing	3/4	28.4	M25
4 Control cable	1/2	22.5	M20
5 Control cable	1/2	22.5	M20

1) Tolerance ±0.2 mm

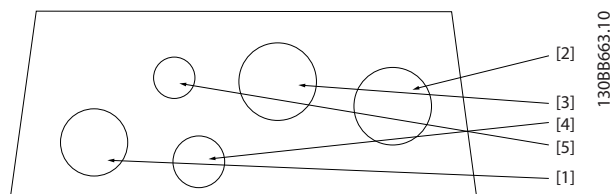
Illustration 8.21 Enclosure Size A2, IP21



Hole number and recommended use	Dimensions <sup>1)</sup>		Nearest metric
	UL [in]	[mm]	
1 Mains	3/4	28.4	M25
2 Motor	3/4	28.4	M25
3 Brake/load sharing	3/4	28.4	M25
4 Control cable	1/2	22.5	M20
5 Control cable	1/2	22.5	M20
6 Control cable	1/2	22.5	M20

1) Tolerance ±0.2 mm

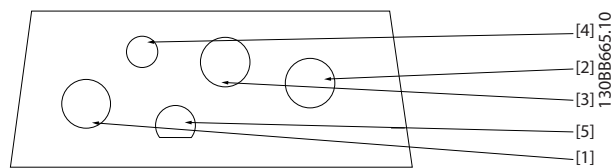
Illustration 8.22 Enclosure Size A3, IP21



Hole number and recommended use	Dimensions <sup>1)</sup>		Nearest metric
	UL [in]	[mm]	
1 Mains	3/4	28.4	M25
2 Motor	3/4	28.4	M25
3 Brake/load sharing	3/4	28.4	M25
4 Control cable	1/2	22.5	M20
5 Removed	-	-	-

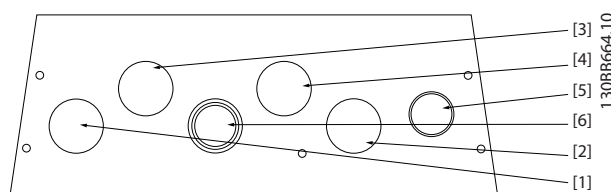
1) Tolerance ±0.2 mm

Illustration 8.23 Enclosure Size A4, IP55



Hole number and recommended use	Nearest metric
1 Mains	M25
2 Motor	M25
3 Brake/load sharing	M25
4 Control cable	M16
5 Control cable	M20

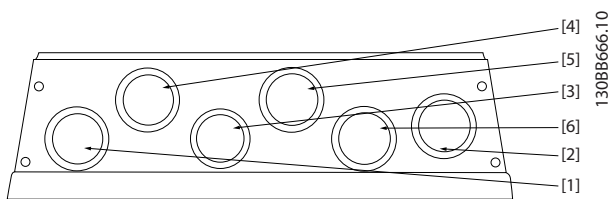
Illustration 8.24 Enclosure Size A4, IP55 Threaded Gland Holes



Hole number and recommended use	Dimensions <sup>1)</sup>		Nearest metric
	UL [in]	[mm]	
1 Mains	3/4	28.4	M25
2 Motor	3/4	28.4	M25
3 Brake/load sharing	3/4	28.4	M25
4 Control cable	3/4	28.4	M25
5 Control cable <sup>2)</sup>	3/4	28.4	M25
6 Control cable <sup>2)</sup>	3/4	28.4	M25

1) Tolerance ±0.2 mm  
2) Knock-out hole

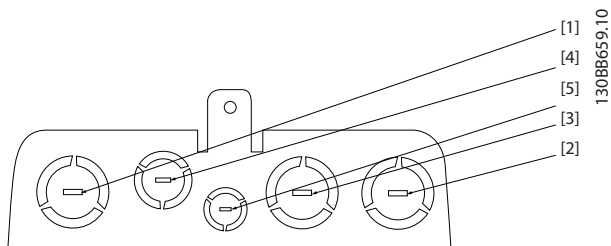
Illustration 8.25 Enclosure Size A5, IP55



Hole number and recommended use	Nearest metric
1 Mains	M25
2 Motor	M25
3 Brake/load sharing	28.4 mm <sup>1)</sup>
4 Control cable	M25
5 Control cable	M25
6 Control cable	M25

1) Knock-out hole

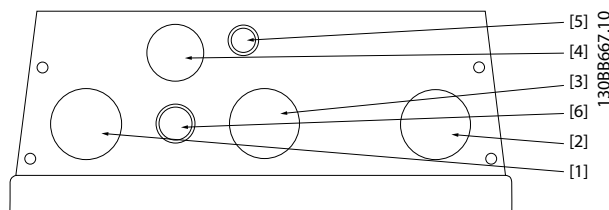
Illustration 8.26 Enclosure Size A5, IP55 Threaded Gland Holes



Hole number and recommended use	Dimensions <sup>1)</sup>		Nearest metric
	UL [in]	[mm]	
1 Mains	1	34.7	M32
2 Motor	1	34.7	M32
3 Brake/load sharing	1	34.7	M32
4 Control cable	1	34.7	M32
5 Control cable	1/2	22.5	M20

1) Tolerance ±0.2 mm

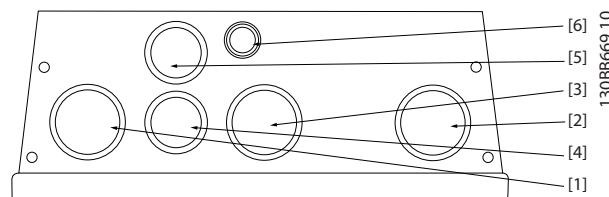
Illustration 8.27 Enclosure Size B1, IP21



Hole number and recommended use	Dimensions <sup>1)</sup>		Nearest metric
	UL [in]	[mm]	
1 Mains	1	34.7	M32
2 Motor	1	34.7	M32
3 Brake/load sharing	1	34.7	M32
4 Control cable	3/4	28.4	M25
5 Control cable	1/2	22.5	M20
5 Control cable <sup>2)</sup>	1/2	22.5	M20

1) Tolerance ±0.2 mm  
2) Knock-out hole

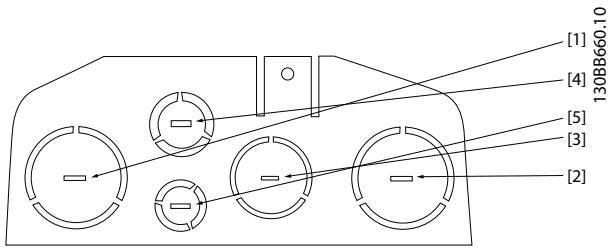
Illustration 8.28 Enclosure Size B1, IP55



Hole number and recommended use	Nearest metric
1 Mains	M32
2 Motor	M32
3 Brake/load sharing	M32
4 Control cable	M25
5 Control cable	M25
6 Control cable	22.5 mm <sup>1)</sup>

1) Knock-out hole

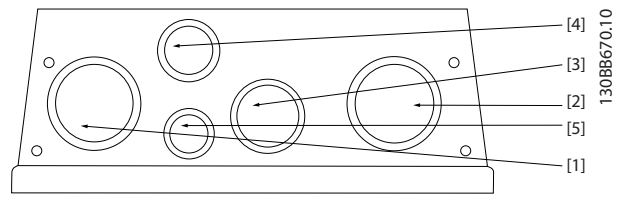
Illustration 8.29 Enclosure Size B1, IP55 Threaded Gland Holes



Hole number and recommended use	Dimensions <sup>1)</sup>		Nearest metric
	UL [in]	[mm]	
1 Mains	1 1/4	44.2	M40
2 Motor	1 1/4	44.2	M40
3 Brake/load sharing <sup>2)</sup>	1	34.7	M32
4 Control cable	3/4	28.4	M25
5 Control cable	1/2	22.5	M20

1) Tolerance  $\pm 0.2$  mm  
2) Mains for S2 variants with Mains Disconnect.

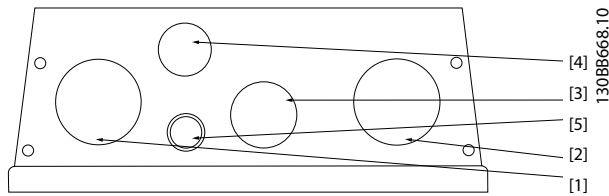
Illustration 8.30 Enclosure Size B2, IP21



Hole number and recommended use	Nearest metric
1 Mains	M40
2 Motor	M40
3 Brake/load sharing <sup>1)</sup>	M32
4 Control cable	M25
5 Control cable	M20

1) Mains for S2 variants with Mains Disconnect.

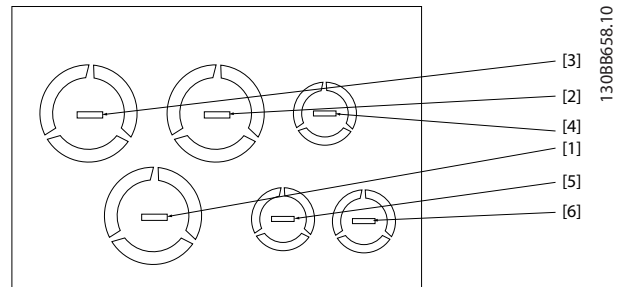
Illustration 8.32 Enclosure Size B2, IP55 Threaded Gland Holes



Hole number and recommended use	Dimensions <sup>1)</sup>		Nearest metric
	UL [in]	[mm]	
1 Mains	1 1/4	44.2	M40
2 Motor	1 1/4	44.2	M40
3 Brake/load sharing <sup>3)</sup>	1	34.7	M32
4 Control cable	3/4	28.4	M25
5 Control cable <sup>2)</sup>	1/2	22.5	M20

1) Tolerance  $\pm 0.2$  mm  
2) Knock-out hole  
3) Mains for S2 variants with Mains Disconnect.

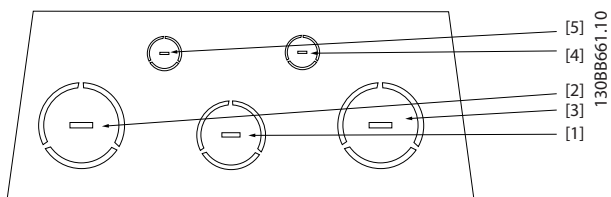
Illustration 8.31 Enclosure Size B2, IP55



Hole number and recommended use	Dimensions <sup>1)</sup>		Nearest metric
	UL [in]	[mm]	
1 Mains	1	34.7	M32
2 Motor	1	34.7	M32
3 Brake/load sharing	1	34.7	M32
4 Control cable	1/2	22.5	M20
5 Control cable	1/2	22.5	M20
6 Control cable	1/2	22.5	M20

1) Tolerance  $\pm 0.2$  mm

Illustration 8.33 Enclosure Size B3, IP21

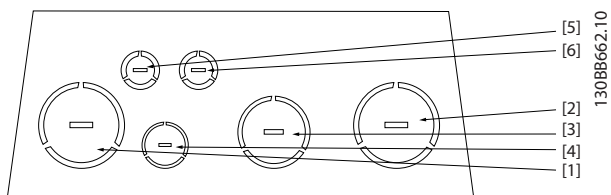


Hole number and recommended use	Dimensions <sup>1)</sup>		Nearest metric
	UL [in]	[mm]	
1 Mains	2	63.3	M63
2 Motor	2	63.3	M63
3 Brake/load sharing	1 1/2	50.2	M50
4 Control cable	3/4	28.4	M25
5 Control cable	1/2	22.5	M20

1) Tolerance  $\pm 0.2$  mm

Illustration 8.34 Enclosure Size C1, IP21

8



Hole number and recommended use	Dimensions <sup>1)</sup>		Nearest metric
	UL [in]	[mm]	
1 Mains	2	63.3	M63
2 Motor	2	63.3	M63
3 Brake/load sharing	1 1/2	50.2	M50
4 Control cable	3/4	28.4	M25
5 Control cable	1/2	22.5	M20
6 Control cable	1/2	22.5	M20

1) Tolerance  $\pm 0.2$  mm

Illustration 8.35 Enclosure Size C2, IP21

**Index**

**A**

Abbreviations..... 9, 47

AC

- brake..... 27, 31, 58
- current..... 19, 20
- input..... 19
- mains..... 19
- waveform..... 19

Acoustic noise..... 39

Address field..... 84

Advanced minimum speed monitoring..... 96, 99, 100, 102

AEO..... 9  
see also *Automatic energy optimisation*

Affinity laws..... 16

Airflow..... 38, 39, 40, 129

Airflow calculation..... 38

Aluminium-housed compact brake resistor..... 120

Aluminium-housed flat-pack brake resistor..... 120

AMA..... 9, 29, 102, 103  
see also *Automatic motor adaptation*

Ambient conditions..... 151

Analog I/O..... 68

Analog input..... 152

Analog output..... 153

Analog speed reference..... 107

Application

- set-up example..... 100
- Cascade control..... 96
- Check valve protection..... 96
- Deragging..... 96, 97
- Dry-run detection..... 96, 97, 102
- End-of-curve detection..... 96
- Flow compensation..... 96, 97
- Flow confirmation..... 96, 99
- Lead pump alternation..... 103, 104
- Low-flow detection..... 96
- Real-time clock..... 96
- Submersible pump..... 96, 99, 102
- Wastewater..... 96

ATEX..... 29, 68, 169

Auto on..... 22

Automatic energy optimisation..... 9, 27, 29  
see also *AEO*

Automatic motor adaptation..... 9, 29, 103  
see also *AMA*

Autoramping..... 39

**B**

Back plate..... 65

Back-up power system..... 53

**Brake**

- chopper..... 59, 66, 115
- current..... 121
- IGBT..... 20
- option..... 20, 67
- power..... 10
- system..... 120
- Braking..... 31
- Braking current..... 88
- Braking torque..... 59
- Dynamic brake..... 20, 31, 58
- Resistor brake..... 31, 58

Brake power..... 59

Brake resistor

- Abbreviations..... 121, 128
- Brake resistor..... 9, 10, 20, 26, 31, 58, 59, 66, 70, 77, 118, 121, 122, 123, 124, 125, 126, 127, 128
- Brake resistor duty cycle..... 58
- Cable cross-section..... 121
- Cabling..... 59

**C**

Cabinet heater..... 37

Cabinet options..... 41

Cable

- entry..... 183
- Entry holes..... 183
- Length..... 152
- Motor cable... 29, 40, 41, 42, 43, 44, 50, 54, 55, 57, 59, 63, 71, 76, 102, 110, 111, 149, 164
- Motor cable length..... 44, 46, 49, 55, 71, 151
- Parallel motor cable..... 44
- Screened cable..... 64
- Specifications..... 151
- Unshielded motor cable..... 54

CFM..... 39

Circuit breaker..... 26, 50, 53, 66, 155, 156, 157, 158

Clearance..... 38, 42, 63, 64

Closed loop..... 21, 22, 23, 30, 33, 85, 96, 102

Closed-loop wizard..... 103

Coast..... 10, 30, 32, 83, 85, 86, 88, 89, 91, 92, 96, 97

Coating..... 39, 65, 115

Coil register..... 85

Comparator..... 31, 32, 96

Compliance

- CE..... 11
- CE mark..... 11
- C-tick..... 12
- Galvanic isolation..... 29, 35, 42, 68, 170, 171, 172
- Marine compliance..... 12
- UL listed..... 12

Condensation..... 37

Contactors..... 66, 69, 70, 106

Control		
bit.....	88, 91	
characteristic.....	154	
input/output.....	152	
logic.....	18	
wire isolation.....	57	
wiring.....	64	
word bit.....	88	
Control card		
Control card performance.....	154	
Control card, 10 V DC output.....	154	
Control card, 24 V DC output.....	154	
Control card, RS485 serial communication.....	152	
USB serial communication.....	155	
Control word bit.....	91	
Conventions.....	10	
Conversion factor.....	82, 87	
Conversion index.....	82, 83	
Cooling... 28, 30, 33, 36, 38, 39, 40, 57, 65, 66, 96, 110, 129, 149		
Cooling conditions.....	64	
Cos $\phi$ .....	53, 68, 150, 154, 167, 171	
CRC check field.....	85	
Current		
Current.....	47	
distortion.....	48, 129	
level.....	152	
limit.....	9, 27, 28	
loops.....	43	
measurement.....	29	
mode.....	152	
range.....	153	
DC current.....	19	
Fundamental current.....	47	
Harmonic current.....	47	
Harmonic current distortion.....	71	
High current.....	33	
Individual harmonic current.....	48	
Input current.....	47	
Intermediate current voltage.....	42	
Leakage current.....	42, 49, 50	
Low current.....	34	
Output current.....	28, 29, 55, 102, 110, 111, 112	
Overcurrent.....	30	
Rated current.....	45, 102	
Rated output current.....	9	
Ripple current.....	33, 71	
<b>D</b>		
Data		
control byte.....	78, 79	
field.....	85	
type.....	82, 87	
DC		
brake.....	58, 83, 85, 88	
current.....	30, 31, 58	
DC-link voltage.....	120	
Definition.....	10, 45, 48, 51	
Delta connection.....	180	
Deragging.....	15	
Derating		
Ambient temperature.....	111	
Automatic.....	27	
Constant torque applications (CT mode).....	110	
Cooling.....	110	
Derating.....	28, 33, 37, 94, 110, 111, 112, 113, 151	
Large cross-section.....	111	
Low air pressure.....	110	
Manual.....	110	
Running at low speed.....	110	
Variable (quadratic) torque applications (VT).....	110	
Digital input.....	153	
Digital output.....	153	
Dimensions.....	73, 74, 75, 94, 163, 183, 184, 185, 186	
Directive		
EMC.....	11	
EMC directive.....	11	
ErP.....	12	
Low-voltage.....	11	
Low-voltage directive.....	11	
Machinery.....	11, 12	
Discharge time.....	13	
Disconnect.....	20, 66, 115	
Displacement power factor.....	150	
Dry-run detection.....	15	
DU/dt testing.....	164	
Dust.....	36, 39, 40, 41	
Duty cycle		
Duty cycle.....	10, 121, 122, 123, 124, 125, 126, 127, 128	
Duty cycle calculation.....	58	
<b>E</b>		
Earth leakage protection.....	42	
Efficiency		
Efficiency.....	9	
Motor efficiency.....	60	
Efficiency.....	16, 27, 28, 29, 59, 60, 68, 103, 149, 151	
Electronic thermal relay.....	57	
see also <i>ETR</i>		

EMC	
Conducted emission.....	44
EMC.....	8, 42, 44, 45, 46, 64
characteristic.....	51
effect.....	51
filter.....	45, 115
immunity.....	46
implementation.....	54
plan.....	45
property.....	51
Emission requirements.....	43, 45
Emissions.....	42
Immunity requirements.....	43, 45
Interference.....	64
Radiated emission.....	44
Test results.....	44
Energy savings.....	15, 16, 17, 31
Environment	
Industrial.....	44, 45, 52, 53
Residential.....	45, 52, 53
Environment.....	151
Equipment optional.....	8
ETR.....	9, 27, 29, 57, 68
see also <i>Electronic thermal relay</i>	
Explosive atmosphere.....	40, 68, 169
External alarm reset.....	106
External command.....	19
External interlock.....	108
Extreme running conditions.....	26
F	
Fan.....	11, 15, 18, 28, 30, 33, 36, 38, 39, 40, 69, 73, 98, 110, 129
FC profile	
Control word.....	88
Protocol overview.....	78
Status word.....	89
Telegram length (LGE).....	79
Feedback	
Feedback.....	23, 25, 61, 69, 85, 102, 107
conversion.....	26
handling.....	25, 37
setting.....	103
signal.....	21, 30
Filter	
AHF 005.....	129
AHF 010.....	129
Common mode.....	134
Common-mode filter.....	71
DU/dt.....	46, 54, 71, 133, 164
Filter.....	40
Harmonic filter.....	71, 129, 130
LC.....	54, 55, 56, 164
Radio frequency interference.....	41
see also <i>RFI</i>	
Sine-wave.....	20, 54, 70, 71, 102
Fixed speed pump.....	69
Flow confirmation.....	15
Flying start.....	27, 28, 30
Frequency bypass.....	30
Frequency converter address.....	78, 79
Function field.....	85
Fuse.....	20, 26, 66, 94, 115, 155, 156, 157, 158, 159, 160, 161, 162
G	
Generator.....	26, 39, 49, 53, 54
Grounding.....	29, 47, 50, 51, 177
H	
Hand on.....	22
Harmonics	
Analysis.....	47
Calculation of harmonics.....	36, 49
Emission requirements.....	48
Harmonic mitigation.....	49
Harmonics.....	8, 19, 37, 47, 48, 49, 51, 52, 53
distortion.....	10, 42, 47
emission standard.....	48
Test result.....	48
Total harmonic distortion.....	47
Voltage harmonics.....	47
High altitude.....	42, 110, 151
High voltage.....	13
High-frequency common-mode core.....	71
Horizontal clearance.....	64
Horizontal load.....	120
Humidity.....	37, 38, 41, 94, 151
I	
I/O.....	66, 67, 69, 116, 6, 171, 172
Improved control.....	18
Index (IND).....	81, 87
Initialising.....	10
Input power.....	19, 64
Insulation resistance monitor.....	66
Interlock.....	108
Intermediate circuit.....	18, 26, 164
Intermediate section.....	20
Inverter.....	18
Inverter section.....	20
IP rating definition.....	41
IP21/NEMA Type 1 enclosure kit.....	72
J	
Jog.....	89



**K**

Kinetic back-up..... 30

**L**

Lambda..... 10, 52

Laws of Proportionality..... 16

LCP..... 9, 34, 61, 74, 93, 99, 104, 115  
see also *Local control panel*

Leakage current..... 14

Load sharing... 13, 20, 26, 46, 115, 119, 136, 137, 138, 139, 140, 141, 142, 143, 144, 145, 146, 147, 148, 149, 183, 184, 185, 186, 187

Loadsharing terminal..... 66

Local control panel..... 9, 34, 61, 115, 118  
see also *LCP*

Logic rule..... 31, 32, 96

Low-flow detection..... 15

**M**

Mains

connection..... 177

drop-out..... 30

shielding..... 65

supply..... 10, 47

Transient..... 19, 53

Maintenance..... 40

Master frequency converter..... 69

Mechanical mounting..... 64

Modbus RTU

Exception code..... 87

Function code..... 86

Message framing structure..... 84

Message structure..... 84

Network configuration..... 84

Overview..... 83

Protocol..... 83

RS485 interface..... 83

Modulation..... 9, 28, 40, 111, 112, 113, 114

Moment of inertia..... 26

Motor

Bearing current..... 46

Bearing stress..... 54

CAN motor..... 102

Grounding..... 54

Insulation..... 46

Insulation stress..... 54, 102

Missing motor phase..... 27

alternation..... 15, 96

connection..... 180

current..... 19, 27, 60, 90

output..... 150

phases..... 26

starter..... 18, 66, 104

thermal protection..... 12, 29, 57, 90

thermistor..... 40, 109

torque..... 93

voltage..... 164

wiring..... 64

Output performance (U, V, W)..... 150

Thermal stress..... 54

Thermistor..... 109

Motor thermal protection..... 109

Mounting bracket..... 75

**O**

Open loop..... 20

Open-loop mode..... 69

Option

Advanced cascade controller..... 68, 96

Basic cascade controller..... 103

Basic Cascade Controller..... 69

Cascade controller..... 35, 68, 104, 105

Cascade controller option..... 69

DeviceNet..... 67, 69, 116

EtherNet IP..... 67, 69, 116

Extended Relay Card MCB 113..... 69

Modbus TCP..... 67, 69, 116

PROFIBUS..... 67, 69, 115, 116

PROFINET..... 67, 69, 116

PTC thermistor card..... 29, 68, 69, 116, 118, 169

Relay card..... 12

Relay Card..... 68, 69, 116, 118, 167, 168, 171

Sensor Input Option MCB 114..... 69

Options

Advanced cascade controller..... 175, 176

Extended cascade controller..... 173

MCB 114..... 172

MCO 101..... 173

MCO 102..... 175

Sensor input..... 172

Ordering		Pre/post lube.....	96, 98
Accessory.....	119	Precautions.....	13
Accessory bag.....	119	Preheat.....	30
Advanced cascade controller.....	118	Preventive maintenance.....	35, 96
Common mode filter.....	134	Process block.....	80
DeviceNet.....	118	Process word.....	82
DU/dt filter.....	133	PROFIdrive profile	
Ethernet/IP.....	118	Control word.....	91
From type code.....	115	Status word.....	92
Modbus TCP.....	118	PT100.....	29, 68, 172
Mounting bracket.....	117	PT1000.....	29, 68, 172
Number.....	115	PTC sensor.....	29
Option.....	119	Public supply network.....	48
PC software.....	119	Pulse input.....	153
PROFIBUS.....	118	Pulse width modulation.....	20
Profinet.....	118	Pump staging.....	104
Sine-wave filter.....	131		
Spare parts.....	119		
Output contactor.....	58, 63		
OVC.....	26, 27		
see also <i>Overtorque control</i>			
Overload		<b>Q</b>	
High overload.....	149, 150	Qualified personnel.....	13
Normal overload.....	135, 139, 150	Quick Menu.....	15, 34, 96, 97, 103
Normal overload mode.....	111, 113		
Overload.....	29, 47, 57, 66, 99	<b>R</b>	
LED.....	67	Radio frequency interference.....	29, 52, 65
protection.....	15, 27, 66	see also <i>RFI</i>	
setpoint.....	29	Ramp	
torque.....	150	Final ramp.....	15, 96, 97, 102, 103
Overtemperature.....	10, 27, 28, 33, 66, 90	Initial ramp.....	102, 103
Overtorque		RCD.....	9, 50, 65
Motor-generated overvoltage.....	26	Real-time clock.....	15, 35
Overtorque.....	26, 27, 31, 39, 58, 70, 150, 154, 170	Rectifier.....	18, 20
control.....	26	Rectifier diode.....	47
Overtorque.....	59	Rectifier section.....	20
		Reference	
<b>P</b>		Reference.....	100, 0
Parameter block.....	80	external.....	23
Parameter number (PNU).....	81	handling.....	23, 24
Parameter value (PWE).....	81	preset.....	23
Payback period.....	17	Remote reference.....	22, 23
PC software.....	35	Regeneration terminal.....	66
PCD.....	80, 82		
Peak Voltage on Motor.....	164		
PELV.....	9, 29, 42, 109, 110, 152, 153, 154, 155, 168, 174		
Phase imbalance.....	27, 33		
PID controller.....	21, 22, 25, 30, 102, 103, 172		
Pilz.....	66		
Pipe fill mode.....	15, 96, 97, 102, 103		
PKE field.....	81		
Point of common coupling.....	48		
Potentiometer.....	108		
Power factor.....	10, 19, 52, 53, 54, 150		

Relay	
Built-in relay.....	83, 103
Load relay.....	68
Output relay.....	29, 91
Relay.....	12, 27, 42, 61, 68, 69, 104, 168, 171, 172
04.....	89
1.....	85, 88, 89, 106, 154
2.....	85, 88, 106, 154
7.....	168
8.....	168
9.....	168
connection.....	62
option.....	62, 68
output.....	62, 154
terminal.....	42, 168, 173, 176, 182
SPDT alarm relay.....	65, 66
SPDT relay.....	68, 171
Remote mounting kit.....	74
Resistor time cycle.....	120
Resonance damping.....	28
RFI	
RFI.....	20, 29, 39, 42, 52, 54
filter.....	20, 39, 41, 44, 49, 52, 65, 66, 115
Rise time.....	164
RMS current.....	19
RS485	
Bus termination.....	77
EMC precautions.....	77
Installation and set-up.....	76
Network connection.....	77
RS485.....	10, 22, 34, 35, 42, 74, 76, 77, 78, 168, 173
Serial interface RS485.....	76
Run permissive.....	31, 109
Run/Stop command.....	108
<b>S</b>	
Safety.....	13, 14, 32, 33, 69, 177, 180
Sensor current.....	20
Sensor thermal.....	20
Setpoint.....	23
Shielding.....	54, 55, 59
Shock.....	39
Short-circuit	
Short-circuit.....	11, 19, 20, 29, 33, 37, 53, 66, 170
(motor phase – phase).....	26
protection.....	26
ratio.....	48
Side-by-side installation.....	64
Slave frequency converter.....	69
Sleep mode.....	15, 28, 31, 96, 97, 104
Slip compensation.....	10, 26
Smart logic control.....	10, 15, 31, 35, 96, 98, 100, 101
SmartStart.....	15, 96
Soft starter.....	18, 70
Software	
Harmonic calculation software (HCS).....	36, 52
HCS.....	54
see also <i>Harmonic Calculation Software</i>	
Language package.....	117
MCT 10 Set-up Software.....	35
MCT 31.....	36
language.....	116, 117
version.....	119
Speed limit.....	21, 27, 57
Speed reference.....	107
Staging bandwidth.....	104
Star connection.....	180
Star/Delta starter.....	70
Star/Delta Starter.....	18
Start/stop field.....	84
Status word.....	80, 82, 85, 86, 90, 97
Steel grid brake resistor.....	120
STO.....	8, 15, 32, 61, 68, 96, 169
Storage.....	34, 35, 36, 37, 42, 87, 95, 151
Switching	
frequency.....	27, 28, 33, 38, 44, 47, 50, 59, 60, 70, 71, 112, 113, 114, 131, 132, 133
on the output.....	27
System	
Operation.....	104
Status.....	104
System design checklist.....	94
<b>T</b>	
Telegram length.....	78, 82
Telegram structure.....	78
Temperature	
Temperature.....	37
ambient.....	37
average.....	38
maximum.....	37, 38
Temperature sensor.....	172
Terminal 37.....	32, 33, 61, 169
Text block.....	80, 87
Thermal protection.....	12
Thermistor.....	10, 42, 57, 67, 169
Thrust bearing.....	102
Torque	
Braking torque.....	27
Constant torque.....	9
CT characteristics.....	10
Full torque.....	30
Rated torque.....	60
Starting torque.....	150
characteristic.....	150
limit.....	9, 27, 57, 90
Variable torque.....	9
VT characteristics.....	11

Transformer.....	47
Transient.....	39, 50
Transient protection.....	19
Trip	
Trip.....	10, 27, 28, 30, 32, 33, 34, 53, 57, 66, 70, 83, 88, 89, 90, 92, 93, 99, 104, 110
level.....	156, 157, 158
locked.....	11, 26
Trip.....	109
True power factor.....	150
<b>U</b>	
U/f.....	59
UL compliance.....	159
Undervoltage.....	51
Unintended motor rotation.....	14
Unintended start.....	13
UPEAK.....	164
<b>V</b>	
Valve control.....	30
Variable control of flow and pressure.....	18
Variable speed pump.....	69
Varying flow over 1 year.....	17
Ventilation.....	129
Vertical clearance.....	64
Vertical load.....	120
Vibration.....	39
Voltage level.....	153
VVC+.....	9, 20
<b>W</b>	
Wall mounting.....	65
Weight.....	37, 94, 134, 163
Windmilling.....	14
Wiring.....	40, 41, 47, 57, 94
Wiring	
Electrical wiring.....	102
Relay wiring.....	169, 174
Wiring.....	61, 63, 105, 173, 176
schematic.....	61
Wiring diagram	
Fixed variable speed pump.....	106
Lead pump alternation.....	106
Wizard.....	15, 96





[www.danfoss.com/drives](http://www.danfoss.com/drives)

.....  
Danfoss can accept no responsibility for possible errors in catalogues, brochures and other printed material. Danfoss reserves the right to alter its products without notice. This also applies to products already on order provided that such alterations can be made without subsequential changes being necessary in specifications already agreed. All trademarks in this material are property of the respective companies. Danfoss and the Danfoss logotype are trademarks of Danfoss A/S. All rights reserved.  
.....

Danfoss A/S  
Ulsnaes 1  
DK-6300 Graasten  
[www.danfoss.com/drives](http://www.danfoss.com/drives)

