



VLT[®] AQUA Drive

Cascade Controller Options MCO 101/102

Operating Instructions

Safety

⚠️ WARNING

HIGH VOLTAGE

Frequency converters contain high voltage when connected to AC mains input power. Qualified personnel only should perform installation, start up, and maintenance. Failure to perform installation, start up, and maintenance by qualified personnel could result in death or serious injury.

⚠️ WARNING

UNINTENDED START

When the frequency converter is connected to AC mains, the motor may start at any time. The frequency converter, motor, and any driven equipment must be in operational readiness. Failure to be in operational readiness when the frequency converter is connected to AC mains could result in death, serious injury, equipment, or property damage.

⚠️ WARNING

DISCHARGE TIME

Frequency converters contain DC-link capacitors that can remain charged even when the frequency converter is not powered. To avoid electrical hazards, disconnect AC mains, any permanent magnet type motors, and any remote DC-link power supplies, including battery back-ups, UPS, and DC-link connections to other frequency converters. Wait for the capacitors to fully discharge before performing any service or repair work. The amount of wait time is listed in the *Discharge Time* table. Failure to wait the specified time after power has been removed before doing service or repair could result in death or serious injury.

Voltage [V]	Minimum Waiting Time (Minutes)				
	4	15	20	30	40
200-240	0.25-3.7 kW	5.5-45 kW			
380-480	0.37-7.5 kW	11-90 kW	110-250 kW		315-1000 kW
525-600	0.75-7.5 kW	11-90 kW			
525-690		11-37 kW	45-400 kW	450-1200 kW	1400 kW
High voltage may be present even when the warning LED display lights are off.					

Discharge Time

Symbols

The following symbols are used in this manual.

⚠️ WARNING

Indicates a potentially hazardous situation which could result in death or serious injury.

⚠️ CAUTION

Indicates a potentially hazardous situation which can result in minor or moderate injury. It can also be used to alert against unsafe practices.

CAUTION

Indicates a situation that could result in equipment or property-damage-only accidents.

NOTICE

Indicates highlighted information to regard with attention to avoid mistakes or operate equipment at less than optimal performance.



Approvals

NOTICE

The T7 (525-690 V) frequency converters are not certified for UL.

Contents

1 Introduction	3
1.1 Purpose of these Operating Instructions	3
1.1.1 Software Version	3
2 Application Types	5
2.1 Overview	5
2.2 Supported Configurations	5
2.2.1 Extension of Basic Cascade - Parameter Group 25** Control Mode	5
2.2.2 Master-Follower Configuration	7
2.2.3 Mixed Pump Configuration	8
2.2.3.1 Unequal Size Pump Configuration	8
2.2.3.2 Mixed Pump Configuration with Alternation	9
2.2.4 Using Soft Starters for Fixed Speed Pumps	10
2.3 Sleep Mode	10
2.3.1 Basic Cascade Controller	11
2.3.2 Master/Follower and Mixed Pump Configurations	11
3 Installation	12
3.1 Mechanical and Electrical Installation	12
3.1.1 Before Start	12
3.1.2 Extended Cascade Controller	
MCO 101	12
3.1.3 Advanced Cascade Controller	
MCO 102	14
4 Configuring the System	16
4.1 Configuring the Extended and Advanced Cascade Controller	16
4.1.1 Setting-up the Cascade Parameters	16
4.1.2 Configuration of Multiple Frequency Converters	16
4.1.3 Closed Loop Control	17
4.1.4 Staging/De-staging of Variable Speed Pumps	17
4.1.5 Staging/De-staging of Fixed Speed Pumps	17
4.2 Operation	18
4.2.1 Pump Status and Control	18
4.2.2 Manual Pump Control	18
4.2.3 Runtime Balancing	19
4.2.4 Pump Spin for Unused Pumps	19
4.2.5 Total Lifetime Hours	19
4.2.6 Alternation of the Lead Pump	19
4.2.7 Staging/De-staging in Mixed Pump Configurations	20
4.2.8 Override Staging/De-staging	20

4.2.9 Minimum Speed De-staging	20
4.2.10 Fixed Speed only Operation	20
4.2.11 Flow Compensation for Applications with Cascade Controller	21
5 Parameter Descriptions	22
5.1 Cascade Controller Parameters	22
5.1.1 Cascade CTL Option, 27-**	24
5.1.3 Control & Status, 27-0*	25
5.1.4 Configuration, 27-1*	26
5.1.5 Bandwidth Settings, 27-2*	26
5.1.6 Staging Speed, 27-3*	28
5.1.7 Staging Settings, 27-4*	29
5.1.8 Alternation Settings, 27-5*	30
5.1.9 Digital Inputs, 27-6*	31
5.1.10 Connections, 27-7*	35
5.1.11 Readouts, 27-9*	36
5.2 Parameter Lists	37
5.2.1 25-** Cascade Controller	37
5.2.2 27-** Cascade CTL Option	38
6 Configuration Examples	41
6.1 Master/Follower	41
6.1.1 Basic Settings	41
6.1.2 Master Drive Settings	41
6.1.3 Follower Drive Settings	42
Index	43

1 Introduction

1.1 Purpose of these Operating Instructions

The purpose of these operating instructions is to describe the Danfoss Cascade Controller Options MCO 101 and MCO 102.

The operating instructions contain information about:

- Application types
- Installation
- Configuring the system
- Parameters
- Configuration examples

These operating instructions are intended for use by qualified personnel. Read these operating instructions in full in order to use the Cascade Controller Options safely and professionally and pay particular attention to the safety instructions and general warnings.

1.1.1 Software Version

<p>Extended Cascade Controller Option for VLT® AQUA Drive Software version: 1.9x</p>
--

Table 1.1 Software Version

NOTICE

MCO 101/102 is software supported from version 1.24 onwards.

1.1.2 Cascade Control

The Cascade Controller consists of an option board containing 3 relays that is installed in option slot B. Once options are installed the parameters needed to support the Cascade Controller functions will be available through the control panel in parameter group 27-**.

MCO 101 and 102 are add-on options extending the supported number of pumps and the functionalities of the built-in Cascade Controller in the VLT® AQUA Drive.

The following options for cascade control are available for the VLT® AQUA Drive:

- Built-in Basic Cascade Controller (standard Cascade Controller)
- MCO 101 (Extended Cascade Controller)
- MCO 102 (Advanced Cascade Controller)

For further information, see 2 *Application Types*.

The Extended Cascade Controller can be used in two different modes:

- with the extended features controlled by parameter group 27-**
- to extend the number of available relays for the Basic cascade controlled by parameter group 25-**

With MCO 101, a total of 5 relays can be used for cascade control and with MCO 102, a total of 8 pumps can be controlled. The options are able to alternate the lead pump with 2 relays per pump.

NOTICE

If MCO 102 is installed, the relay option MCB 105 can extend the number of relays to 13.

Application

Cascade control is a common control system used to control parallel pumps or fans in an energy efficient way.

The Cascade Controller option enables control of multiple pumps configured in parallel by:

- Automatically turning individual pumps on/off
- Controlling the speed of the pumps

When using Cascade Controllers, the individual pumps are automatically turned on (staged) and turned off (de-staged) as needed in order to satisfy the required system output for flow or pressure. The speed of pumps connected to the VLT® AQUA Drive is also controlled to provide a continuous range of system output.

Designated use

The Cascade Controller options are designed for pump applications, however, it is also possible to use Cascade Controllers in any application requiring multiple motors configured in parallel.

Operating principle

The Cascade Controller software runs from a single frequency converter with Cascade Controller option (master drive). It controls a set of pumps, each controlled

by a frequency converter or connected to a contactor or a soft starter.

Additional frequency converters in the system (follower drives) do not need any Cascade Controller option card. They are operated in open loop mode and receive their speed reference from the master drive. Pumps connected to follower drives are referred to as variable speed pumps.

Pumps connected to mains through a contactor or through a soft starter are referred to as fixed speed pumps.

Each pump, variable speed or fixed speed, is controlled by a relay in the master drive.

The Cascade Controller options can control a mix of variable speed and fixed speed pumps.

Other resources are available to understand advanced functions and programming.

- The *VLT® AutomationDrive FC 302 Operating Instructions* provide details on installation and operation of the frequency converter.
- The *VLT® AutomationDrive FC 302 Programming Guide* provides greater detail on working with parameters and many application examples.
- The *VLT® AutomationDrive FC 302 Design Guide* provides detailed capabilities and functionality to design motor control systems.
- Supplemental publications and manuals are available from Danfoss.
See www.danfoss.com/BusinessAreas/DrivesSolutions/Documentations/Technical+Documentation.htm for listings.
- Optional equipment may change some of the procedures described. Reference the instructions supplied with those options for specific requirements. Contact the local Danfoss supplier or visit the Danfoss website: www.danfoss.com/BusinessAreas/DrivesSolutions/Documentations/Technical+Documentation.htm, for downloads or additional information.

2 Application Types

2.1 Overview

Built-in	1 VSP + 2 FSP parameter group 25-** Cascade Controller	-	-
MCO 101	1 VSP + 5 FSP parameter group 25-** Cascade Controller	1 to 6 VSP + 1 to 5 FSP (max. 6 pumps) parameter group 27-** Cascade CTL Option	6 VSP parameter group 27-** Cascade CTL Option
MCO 102	1 VSP + 8 FSP parameter group 25-** Cascade Controller	1 to 8 VSP + 1 to 7 FSP (max. 8 pumps) parameter group 27-** Cascade CTL Option	8 VSP parameter group 27-** Cascade CTL Option

Table 2.1 Application Overview

VSP = Variable Speed Pump (directly connected to the frequency converter)

FSP = Fixed Speed Pump (the motor could be connected via contactor, soft starter or star/delta starter)

be used to extend the numbers of relays for cascade control. For instance if a new pump is added to the system.

2.2 Supported Configurations

When setting-up the system, create a hardware configuration, which communicates the number of connected pumps and frequency converters to the master. The necessary hardware is explained in the following hardware configuration examples.

Enable the Basic Cascade Controller in 27-10 Cascade Controller by selecting [3] Basic Cascade Ctrl. Refer to VLT® AQUA Drive Programming Guide for further programming with parameter group 25-** settings.

Illustration 2.1 and Illustration 2.2 show the external wiring needed for systems with alternating lead pump of 4 pumps using basic cascade and MCO 101 as relay extension.

2.2.1 Extension of Basic Cascade - Parameter Group 25-** Control Mode

Use of the extended cascade option MCO 101 as an extension of the built-in basic cascade in the frequency converter

In applications already controlled by the built-in Cascade Controller in parameter group 25-**, the option card can

2

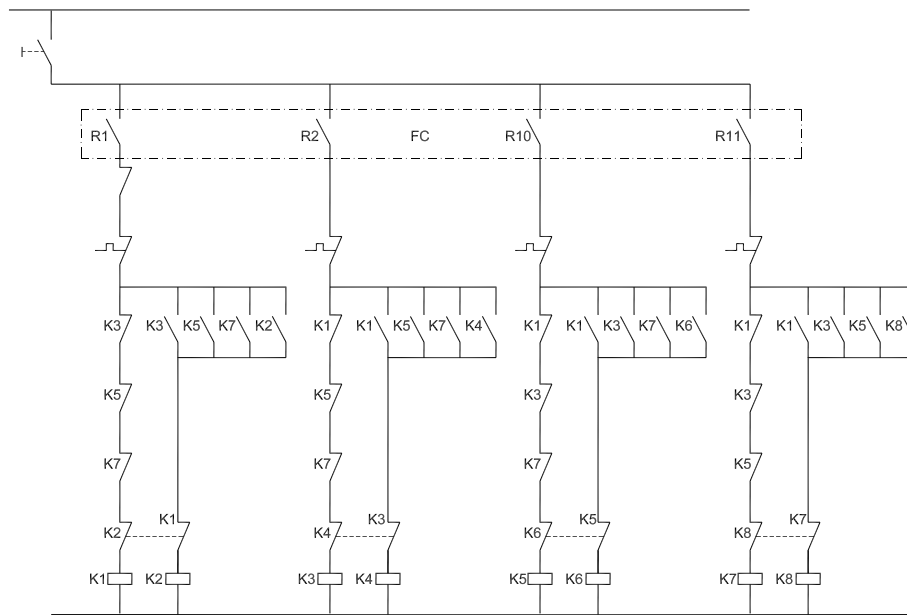

Illustration 2.1 Control Circuit Alternating Lead Pump (4 Pumps)

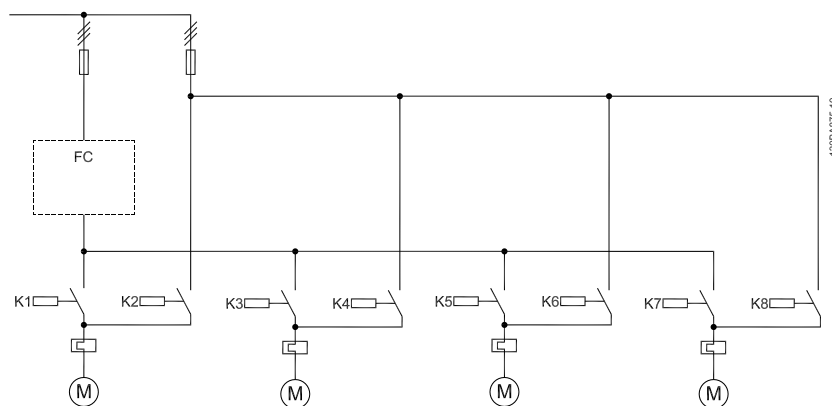

Illustration 2.2 Mains Circuit Alternating Lead Pump (4 Pumps)

The fixed speed pump configuration provides a cost effective method for controlling up to 9 pumps. It is able to control system output by controlling the number of running pumps as well as the speed of the single variable speed pump.

In this configuration the VLT® AQUA Drive controls one variable speed pump and up to 8 fixed speed pumps. The fixed speed pumps are staged and de-staged as needed through contactors direct online. The variable speed pump provides the finer level of control needed between the stages.

The direct online pumps are staged or de-staged depending on the feedback.

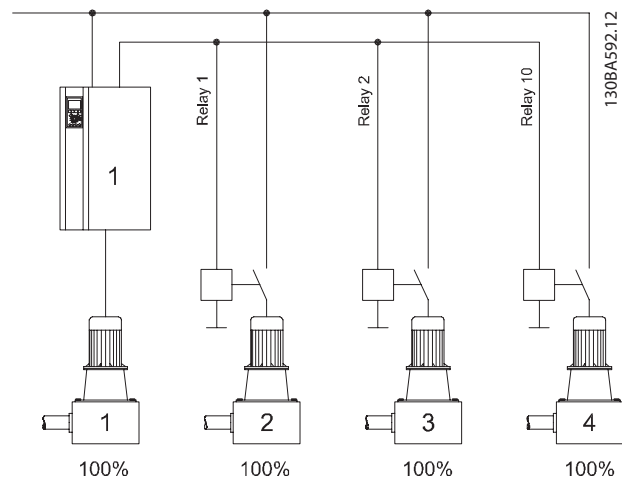

Illustration 2.3 Fixed Speed Pump Configuration Example

NOTICE

If the pumps are not equal in size or if 2 relays per pump are used, a Mixed Pump Configuration has to be chosen.

For the configuration shown in *Illustration 2.3*, relay selections in parameter group 27-7* *Connections* are as follows

- 27-70.0 RELAY 1 → [73] Pump 2 to Mains
- 27-70.1 RELAY 2 → [74] Pump 3 to Mains
- 27-70.9 RELAY 10 → [75] Pump 4 to Mains
- 27-70.10 RELAY 11 → [0] Standard Relay
- 27-70.11 RELAY 12 → [0] Standard Relay

NOTICE

Pressure fluctuations during staging/de-staging transitions may occur and it may be less energy efficient than the master-follower configurations.

2.2.2 Master-Follower Configuration

The master-follower cascade control mode offers the best performance, the most precise control and maximum energy savings. It controls multiple equal sized pumps in parallel, running all pumps at the same speed and stages the pumps on and off according to system requirements. Compared to traditional cascade control the number of running pumps is controlled by speed instead of feedback. To obtain the highest energy saving the stage on and off speed must be set correctly according to the system. In this example terminal 27 of the master drive is used as pulse output for the reference and the terminals 29 of the follower drives are used as pulse input for this reference. While the master drive is running in closed loop, the followers are running in open loop. All follower drives are connected to mains and motor in the same way as the master drive.

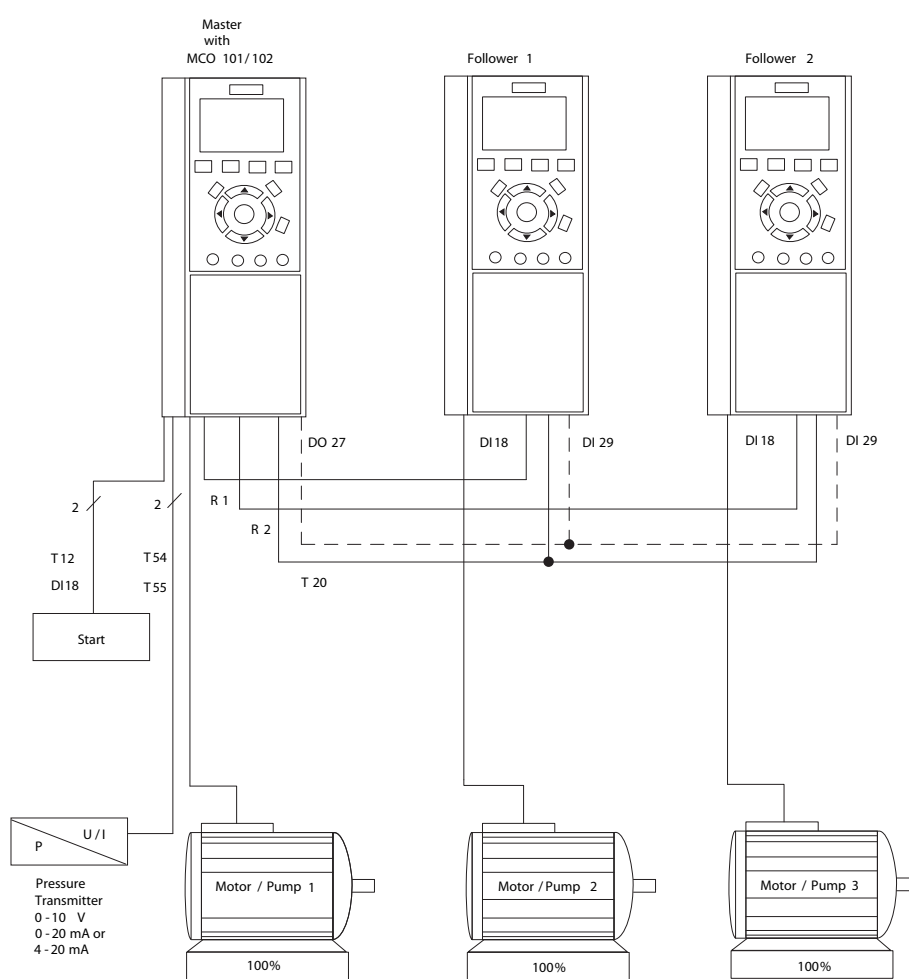

Illustration 2.4 Basic Wiring Principle (Example)

In this configuration each pump is controlled by a frequency converter. All pumps and frequency converters must be of the same size. Staging and de-staging decisions are made based on the speed of the frequency converters. The constant pressure is controlled by the master drive operating in closed loop. The speed will be the same in all running pumps with extended control.

In the Master/Follower mode, MCO 101 supports up to 6 pumps - MCO 102 up to 8 pumps. See 6.1 Master/Follower for further details.

For the configuration shown *Illustration 2.4* relay selections in parameter group 27-7* Connections are as follows:

- 27-70.0 RELAY 1 → [1] Drive 2 Enable
- 27-70.1 RELAY 2 → [2] Drive 3 Enable
- 27-70.9 RELAY 10 → [0] Standard Relay
- 27-70.10 RELAY 11 → [0] Standard Relay
- 27-70.11 RELAY 12 → [0] Standard Relay

The system will automatically runtime balance all pumps depending on the pump prioritization made in 27-16 Runtime Balancing. The master/follower system will provide a certain level of redundancy. If the master drive trips, it will continue to control the follower drives.

NOTICE

MCB 107 External 24 V DC power supply can be added to increase the level of redundancy.

Relays set to [0] Std. Relay, can be used as general purpose relays, controlled by parameter group 5-4* Relays.

2.2.3 Mixed Pump Configuration

This configuration combines some of the benefits of the master follower configuration with some of the initial cost savings of the fixed speed configuration. It is a good choice when the extra capacity of the fixed pumps is rarely needed.

The mixed pump configuration supports a mix of variable speed pumps connected to frequency converters as well as additional fixed speed pumps. The variable speed pumps are staged on and de-staged first based on frequency converter speed. The fixed speed pumps are then staged on last and de-staged last based on the feedback pressure.

NOTICE

All variable speed pumps and frequency converters must be the same size. Fixed speed pumps may be of different sizes.

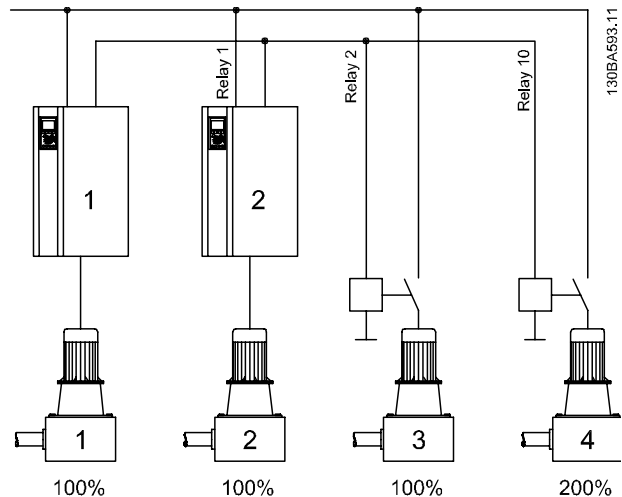

Illustration 2.5 Example

For this configuration relay selections in parameter group 27-7* Connections are as follows:

- 27-70.0 RELAY 1 → [1] Drive 2 Enable
- 27-70.1 RELAY 2 → [74] Pump 3 to Mains
- 27-70.9 RELAY 10 → [75] Pump 4 to Mains
- 27-70.10 RELAY 11 → [0] Standard Relay
- 27-70.11 RELAY 12 → [0] Standard Relay

2.2.3.1 Unequal Size Pump Configuration

The Unequal Size Pump configuration supports a limited mix of fixed speed pumps in different sizes. It provides for the largest range of system output with the smallest number of pumps.

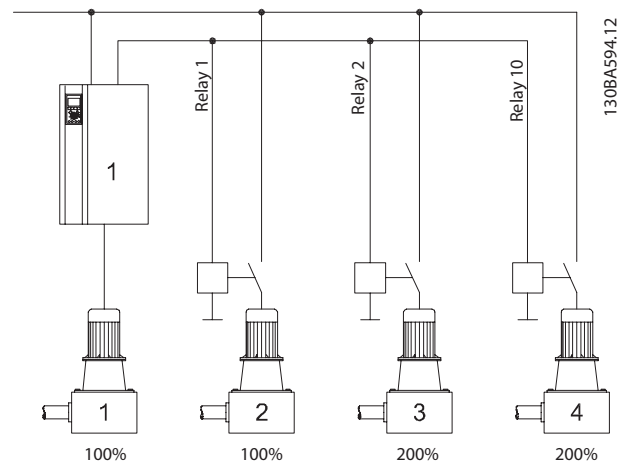

Illustration 2.6 Example

For this configuration relay selections in parameter group 27-7* Connections are as follows:

- 27-70.0 RELAY 1 → [73] Pump 2 to Mains
- 27-70.1 RELAY 2 → [74] Pump 3 to Mains

27-70.9 RELAY 10 → [75] Pump 4 to Mains

27-70.10 RELAY 11→ [0] Standard Relay

27-70.11 RELAY 12→ [0] Standard Relay

For a configuration to be valid, it must be possible to stage pumps in increments of 100% of the size of the master drive's variable speed pump. The variable speed pump must control the output between the fixed speed stages, see *Illustration 2.7*.

100% is defined as the maximum flow produced by the pump connected to the master drive. The fixed speed pumps must be multiples of this size.

NOTICE

Other valid configurations than the ones shown in *Table 2.2* are possible

Variable Speed	Fixed Speed
100%	100% + 200% (see <i>Illustration 2.7</i>)
100%	100% + 200% + 200%
100%	100% + 100% + 300%
100%	100% + 100% + 300% + 300%
100%	100% + 200% + 400%
100% + 100%	200%
100% + 100%	200% + 200%

Table 2.2 Valid Configurations

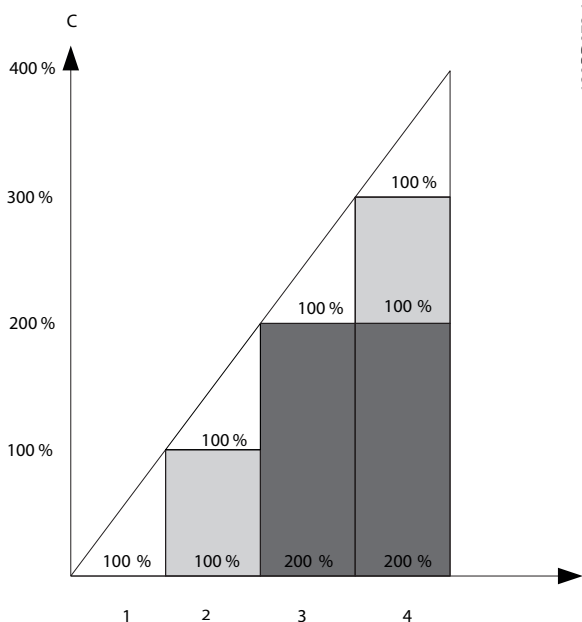

Illustration 2.7 Valid Configuration Example

NOTICE

Invalid configurations, like in *Illustration 2.8*, will still run but will not stage on all pumps. This feature allows for limited operation if a pump fails or is interlocked.

Variable Speed	Fixed Speed	
100%	200%	(no control between 100% and 200%)
100%	100% + 300%	(no control between 200% and 300%) (see <i>Illustration 2.8</i>)
100%	100% + 200% + 600%	(no control between 400% and 600%)

Table 2.3 Invalid Configurations

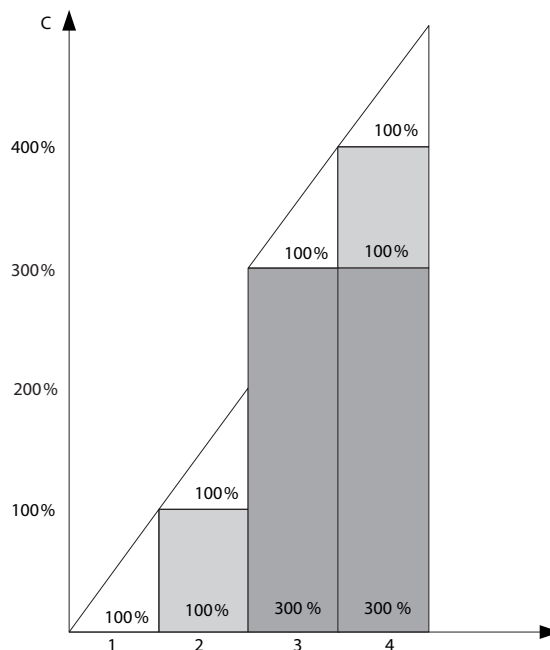

Illustration 2.8 Invalid Configuration Example

2.2.3.2 Mixed Pump Configuration with Alternation

In this configuration the frequency converter alternates between two pumps and controls the other as additional fixed speed pump. The Cascade Controller attempts to balance the running hours of the pumps.

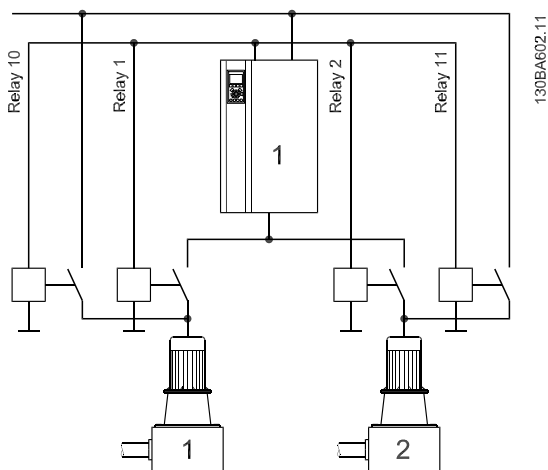

Illustration 2.9 Example 1

As *Illustration 2.9* the two pumps can be either variable speed or fixed speed with equal running hours.

For this configuration relay selections in parameter group 27-7* *Connections* are as follows:

- 27-70.0 RELAY 1 → [8] Pump 1 to Drive 1
- 27-70.1 RELAY 2 → [16] Pump 2 to Drive 1
- 27-70.9 RELAY 10 → [72] Pump 1 to Mains
- 27-70.10 RELAY 11 → [73] Pump 2 to Mains
- 27-70.11 RELAY 12 → [0] Standard Relay

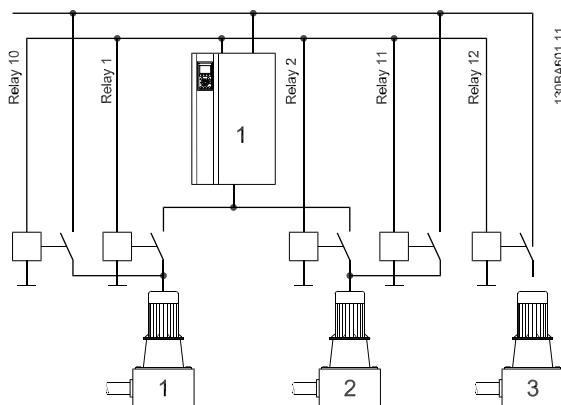

Illustration 2.10 Example 2

With equal running hours for all three pumps, pump 1 and 2 can be either variable speed or fixed speed.

For this configuration relay selections in group 27-7* *Connections* are as follows:

- 27-70.0 RELAY 1 → [8] Pump 1 to Drive 1
- 27-70.1 RELAY 2 → [16] Pump 2 to Drive 1
- 27-70.9 RELAY 10 → [72] Pump 1 to Mains
- 27-70.10 RELAY 11 → [73] Pump 2 to Mains

27-70.11 RELAY 12 → [74] Pump 3 to Mains

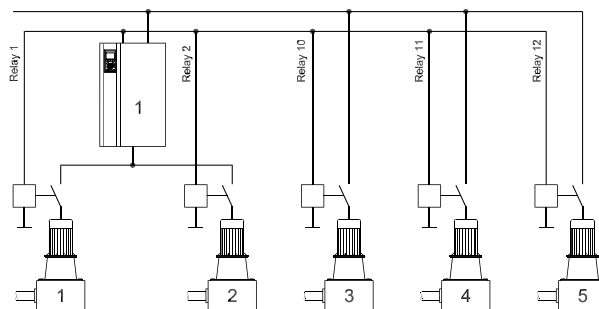

Illustration 2.11 Example 3

Pumps 1 and 2 alternate each with 50% of the running hours. The fixed speed pumps turned on and off as needed with equal running time between them.

For this configuration relay selections in parameter group 27-7* *Connections* are as follows:

- 27-70.0 RELAY 1 → [8] Pump 1 to Drive 1
- 27-70.1 RELAY 2 → [16] Pump 2 to Drive 1
- 27-70.9 RELAY 10 → [74] Pump 3 to Mains
- 27-70.10 RELAY 11 → [75] Pump 4 to Mains
- 27-70.11 RELAY 12 → [76] Pump 5 to Mains

2.2.4 Using Soft Starters for Fixed Speed Pumps

Soft Starters can be used in place of contactors for any configuration using fixed speed pumps.

NOTICE

Mixing Soft Starters and contactors prevents control of output pressure during staging and de-staging transitions. Use of soft starters delays staging due to the ramp time of the fixed speed pump.

2.3 Sleep Mode

If the load on the system allows for stop of the motor and the load is monitored, the motor can be stopped by activating the Sleep Mode function. This is not a normal Stop command, but ramps the motor down to 0 RPM and stops energizing the motor. When in Sleep Mode, certain conditions are monitored to find out when load has been applied to the system again.

Activate Sleep Mode either from the Low Power Detection/Low Speed Detection or via an external signal applied to one of the digital inputs (must be programmed via parameter group 5-1* *Digital Inputs*). To use for example an electro-mechanical flow switch to detect a no

flow condition and activate Sleep Mode, the action takes place at raising edge of the external signal applied (otherwise the frequency converter would never come out of Sleep Mode again as the signal would be steady connected).

Implementation and configuration of Sleep Mode depends on the hardware configuration and the requirements.

2.3.1 Basic Cascade Controller

For Basic Cascade applications can be used and configured exactly as it is described for single pump applications in the Programming Guide. See descriptions of the parameter groups 22-2*, 22-3* and 22-4* for further details.

Low Speed Detection as well as Low Power Detection in combination with the timers for minimum run time, minimum sleep time and the boost feature are supported. The feedback from the pressure transducer is monitored and when this pressure has dropped with a set percentage below the normal set point for pressure (22-44 *Wake-up Ref./FB Difference*), the motor will ramp up again and pressure will be controlled for reaching the set value.

2.3.2 Master/Follower and Mixed Pump Configurations

In multiple drive applications two different ways of the Sleep Mode can be used.

It is possible to use the Sleep Mode as it is described for the Basic Cascade Controller. For this configuration it is essential, that the drive with the cascade controller option is the last drive running after de-staging. This is achieved by giving the connected pump the highest priority in the parameters for runtime balancing (e.g. by programming the drive with the MCO 101 or the MCO 102 as "Balanced Priority 1" and all other drives/pumps as "Balanced Priority 2" in 27-16 *Runtime Balancing*).

The other way makes usage of the Stage Off speeds in parameter group 27-3* *Staging Speed*. This method requires no special priority settings and therefore allows the balancing of the running hours for all pumps.

In the following example the Sleep Mode in a Master/Follower application is entered at 30 Hz.

	Stage ON [Hz]	Stage OFF [Hz]
Stage 1	48.5 (i.e. parameter 2732.1)	30 (i.e. parameter 2734.1)
Stage 2	48.5 (i.e. parameter 2732.2)	40 (i.e. parameter 2734.2)
Stage 3	48.5 (i.e. parameter 2732.3)	42 (i.e. parameter 2734.3)

Table 2.4

This mode is activated by programming the corresponding speed in 27-33 *Stage Off Speed [RPM]* or 27-34 *Stage Off Speed [Hz]* respectively.

The value for this speed has to be higher than the minimum speed in 4-11 *Motor Speed Low Limit [RPM]* or 4-12 *Motor Speed Low Limit [Hz]*.

The value for the override limit in 27-21 *Override Limit* causes the frequency converter to wake-up again. The value is entered as a % of the Maximum Reference as programmed in 3-03 *Maximum Reference*.

See also 6 *Configuration Examples* for further details and the entire description of the required programming steps for a Master/Follower application.

3 Installation

3.1 Mechanical and Electrical Installation

3.1.1 Before Start

3

NOTICE

Before start, interrupt the power supply to the frequency converter. Never install an option card into the frequency converter during operation.

Voltage [V]	Minimum Waiting Time (Minutes)			
	4	7	15	20
200-240	0.25-3.7 kW		5.5-45 kW	
380-480	0.37-7.5 kW		11-90 kW	
525-600	0.75-7.5 kW		11-90 kW	
525-690		1.1-7.5 kW	11-90 kW	
3x400				90-250 kW
3x400				110-315 kW
3x500				110-315 kW
3x500				132-355 kW
3x525				75-250 kW
3x525				90-315 kW
3x690				90-250 kW
3x690				110-315 kW

High voltage may be present even when the warning LED display lights are off.

Table 3.1 Discharge Time

NOTICE

Export Control

From software version 6.72 the output of the frequency converter is limited to 590 Hz. Software version 6x.xx is a special software for export to countries where special legislation for export control applies. In this version the output of the frequency converter is also limited to 590 Hz, the difference from standard software is that it cannot be flashed, i.e. neither downgraded nor upgraded.

3.1.2 Extended Cascade Controller MCO 101

The MCO 101 option includes 3 pieces of change-over contacts and can be fitted into option slot B.

Max terminal load (AC)	240 V AC 2 A
Max terminal load (DC)	24 V DC 1 A
Min terminal load (DC)	5 V 10 mA
Max switching rate at rated load/min load	6 min ⁻¹ /20 s ⁻¹

Table 3.2 Electrical Data

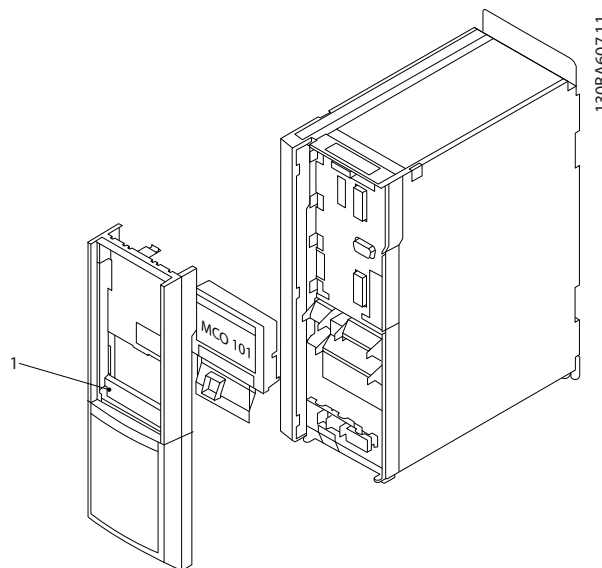

Illustration 3.1 Mounting of B Options

1	Dismount MCO 101 option to access RS-485 termination (S801) or current/voltage switches (S201, S202)
---	--

Table 3.3

How to add the MCO 101 option:

1. Disconnect power to the frequency converter.
2. Disconnect power to the live part connections on relay terminals.
3. Remove the LCP, the terminal cover and the cradle from the FC 202.
4. Fit the MCO 101 option in slot B.
5. Connect the control cables and relief the cables by the enclosed cable strips.
6. Fit the extended cradle and terminal cover.
7. Remount the LCP.
8. Connect power to the frequency converter.

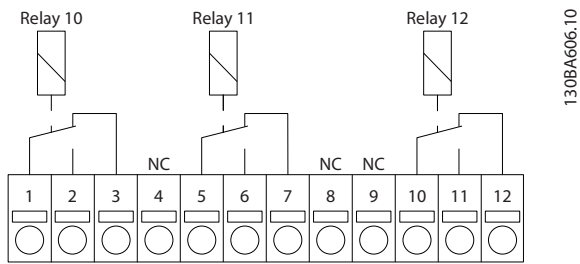

Illustration 3.2 Usage of Connections

130BA606.10

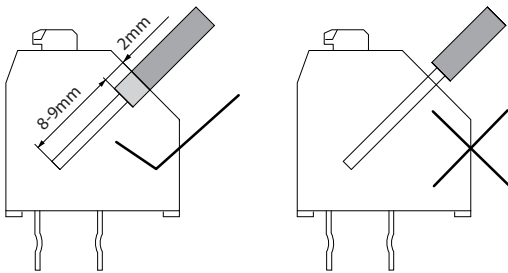

Illustration 3.3 Mounting of Cables

130BA177.10

WARNING

Do not combine low voltage parts and PELV systems (see *Illustration 3.4*).

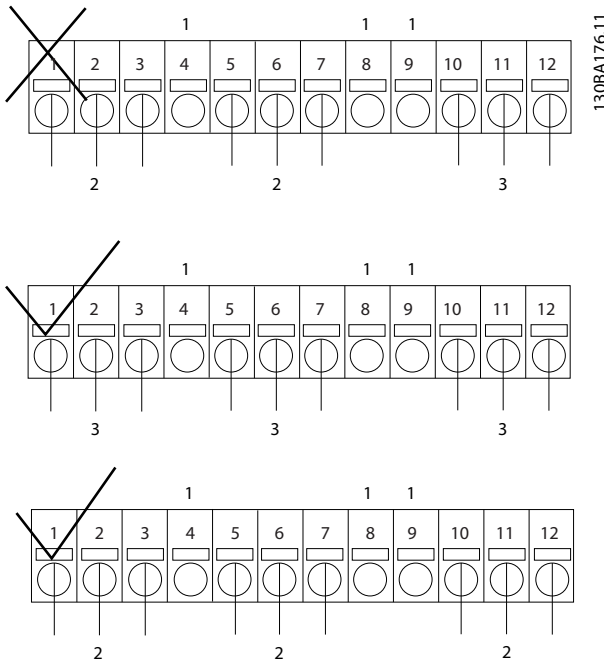

Illustration 3.4 Incorrect and Correct Relay Wiring

130BA176.11

1	NC
2	Live part
3	PELV

Table 3.4 Legend to Correct Relay Wiring

3.1.3 Advanced Cascade Controller MCO 102

The VLT Advanced Cascade Control Card MCO 102 option is exclusively intended for use in option slot C1. The mounting position of C1 options is shown in *Illustration 3.5*.

Max terminal load (AC)	240 V AC 2 A
Max terminal load (DC)	24 V DC 1 A
Min terminal load (DC)	5 V 10 mA
Max switching rate at rated load/min load	6 min ⁻¹ /20 s ⁻¹

Table 3.5 Electrical Data, MCO 102

Tools required

Some items are needed for the installation of a C option mounting kit (depending on the enclosure):

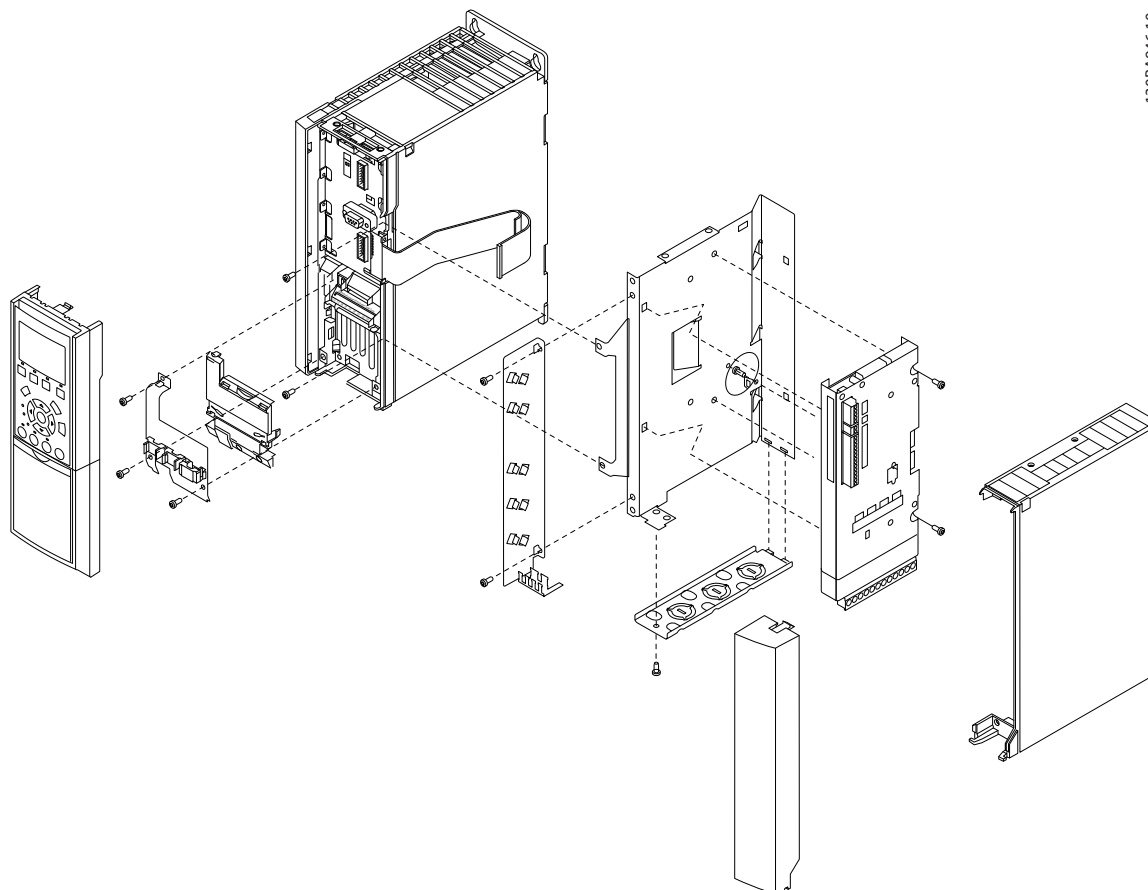

Illustration 3.5 Enclosure A2, A3 (and B3) 40 mm (only one C option)

Type	Description	Ordering number
Options		
MCF 105	Mounting Kit frame size A2 and A3 (40 mm for one C Option)	130B7530
MCF 105	Mounting Kit Frame size A5	130B7532
MCF 105	Mounting Kit Frame size B, C, D, E, F1 and F3 (Except B3)	130B7533
MCF 105	Mounting Kit frame size B3 (40 mm for one C Option)	130B1413
Accessory Bag		
MCO 102	Accessory Bag	130B0152

Table 3.6 Ordering Numbers for Mounting Kits and Accessory Bag

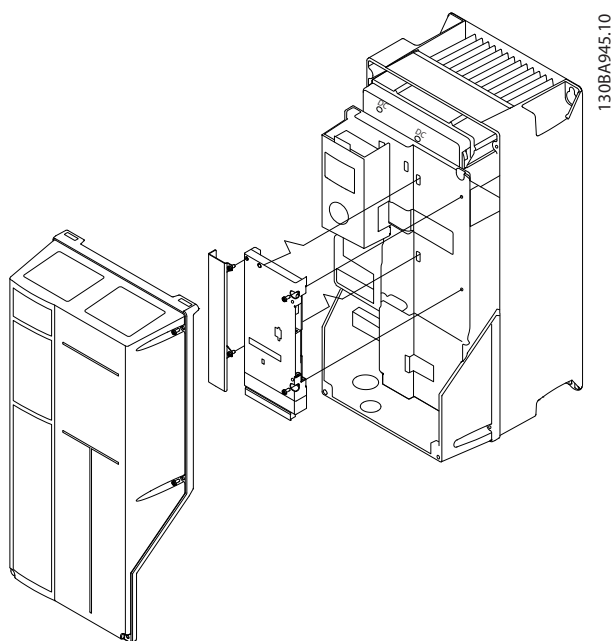
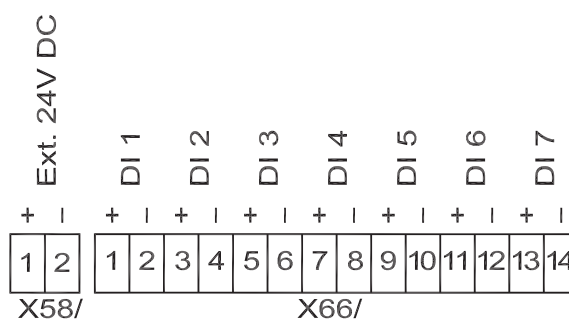

Illustration 3.6 Enclosures B (except B3) and C



130BB026.11

Illustration 3.8 Advanced Cascade Controller MCO 102
Terminal Connections to the 7 Digital Inputs and Access to the Internal 24 V DC

3

How to add the MCO 102 option

1. Disconnect power.
2. Disconnect power to the live part connections on relay terminals.
3. Remove the LCP, the terminal cover and the cradle from the FC 202.
4. Fit the MCO 102 option in slot C1.
5. Connect the control cables and relief the cables by the enclosed cable strips.
6. Fit the extended cradle and terminal cover.
7. Remount the LCP.
8. Connect power to the frequency converter.

Wiring the Terminals

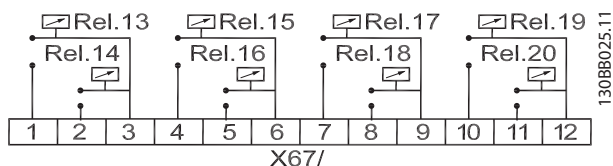

Illustration 3.7 Advanced Cascade Controller MCO 102
Terminal Connections, 8 Relays

4 Configuring the System

4.1 Configuring the Extended and Advanced Cascade Controller

The Extended- and Advanced Cascade Controller can be quickly configured using many of the default parameters. For more information about application types and on how to use advanced features of the Cascade Controller options, see also *2 Application Types*.

NOTICE

To avoid a misconfiguration, check the settings even if the parameters have their default values.

4.1.1 Setting-up the Cascade Parameters

Configure the Cascade Controller as follows:

1. Select values for the parameters in parameter group 27-1* *Configuration*.

Parameter	Description
27-10	Cascade Controller can be used to enable or disable the Extended Cascade Controller. The mixed pump selection is the general selection for the Cascade Controller. If using one frequency converter per pump the master-follower configuration can be selected reducing the number of parameters needed to setup the system.
27-11	Set number of frequency converters
27-12	Number of pumps - will default to the number of frequency converters.
27-14	Pump capacity for each pump (Indexed Parameter) - If all pumps are the same size the default values shall be used. To adjust: first choose pump, press [OK] and adjust the capacity.
27-16	Runtime balancing for each pump (Indexed Parameter) - If the system should equally balance the running hours between the pumps then use the default values.
27-17	Motor Starters - All fixed speed pumps must be the same.
27-18	Spin time for unused pumps - Depends on the size of the pumps.

Table 4.1

2. Define relays in parameter group 27-7* *Connections*

- Assign one relay for each follower drive in the system
- Assign the relays for the fixed speed pumps.
- If it is necessary to have a single frequency converter alternate between two pumps, then assign additional relays.

NOTICE

Any unused relays will be available for other functions through the parameter group 5-4* *Relays*.

4.1.2 Configuration of Multiple Frequency Converters

If more than one frequency converter is used with the Cascade Controller the master drive sets the frequency for all frequency converters via a digital signal.

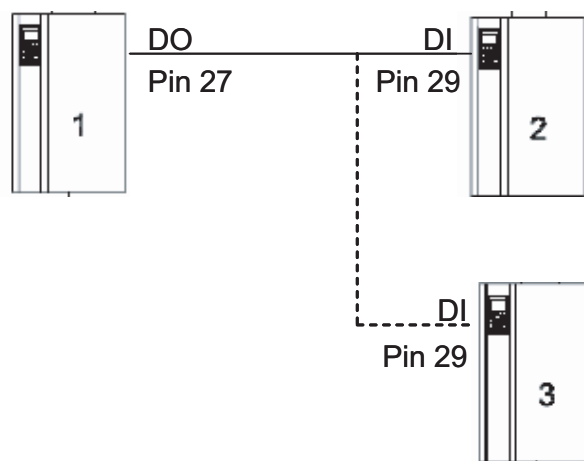

130BA608.10

Illustration 4.1 Multiple Frequency Converters

NOTICE

All frequency converters always run at the same speed.

1. Set basic cascade parameters, see *4.1.1 Setting-up the Cascade Parameters*
2. Set 5-01 *Terminal 27 Mode* to [1] *Output*, 5-30 *Terminal 27 Digital Output* to [55] *Pulse output* and 5-60 *Terminal 27 Pulse Output Variable* to [116] *Cascade ref*.
3. Set each follower drive to open loop, set 1-00 *Configuration Mode* to [0] *Open Loop* and 3-15 *Reference 1 Source* to selection [7] *Pulse input* 29 and 5-13 *Terminal 29 Digital Input* to [32] *Pulse input*.

NOTICE

3-41 Ramp 1 Ramp Up Time and 3-42 Ramp 1 Ramp Down Time must be the same for the master drive and for all follower drives in the system.

4. Set the ramps fast enough to enable the PID controller to maintain control of the system.

4.1.3 Closed Loop Control

The master drive is the primary controller for the system. It monitors the output pressure, adjusts the speed of the frequency converters and decides when to add or remove stages.

To perform this function:

1. setup the master drive closed loop mode with a feedback sensor connected to an analog input of the frequency converter.
2. setup the PID controller of the master drive to match the needs of the installation.

For further information on setting up the PID parameters, see the VLT® AQUA Drive Programming Guide. See also 6.1 Master/Follower.

4.1.4 Staging/De-staging of Variable Speed Pumps

Staging occurs when the speed of the frequency converter has reached the value in 27-31 Stage On Speed [RPM] (27-32 Stage On Speed [Hz]). At this speed the system pressure is still maintained but the pumps start to operate outside of their peak efficiency points. Staging on an additional pump will lower the speed of all running pumps and provide a more energy efficient operation.

In master-follower configurations and mixed pump configurations the variable speed pumps are staged and de-staged based on the speed of the frequency converters.

De-staging occurs when the speed of the frequency converters drops below the value in 27-33 Stage Off Speed [RPM] (27-34 Stage Off Speed [Hz]). At this speed the system pressure is still maintained but the pumps are beginning to operate below their peak efficiency points. De-staging a pump will cause the speed of the frequency converters to increase into a more energy efficient range.

27-31 Stage On Speed [RPM] (27-32 Stage On Speed [Hz]) and 27-33 Stage Off Speed [RPM] (27-34 Stage Off Speed [Hz]) are installation dependent. These parameters are indexed parameters with one set of entries for each pump stage.

The stage on and de-stage off speed can be auto tuned during automation or set manually. If Auto-tune is enabled

the system will start operation using default settings or the pre settings done by the user in 27-31 Stage On Speed [RPM] (27-32 Stage On Speed [Hz]) and 27-33 Stage Off Speed [RPM] (27-34 Stage Off Speed [Hz]) before enabling the auto-tune.

The tuning ensures optimum energy efficiency of the system. See Illustration 4.2.

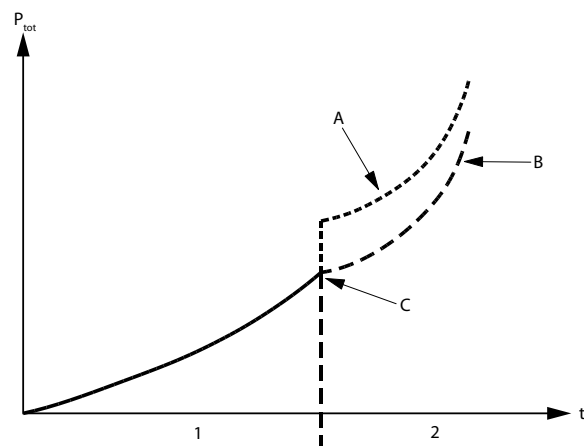

Illustration 4.2

1	1 pump running
2	2 pumps running
A	Incorrect stage on speed adjustment
B	Correct stage on speed adjustment
C	Stage on speed pump 2

Table 4.2

During operation the system monitors the actual energy consumption and optimises every time a stage or de-stage takes place.

Parameter	Range	Default
27-30 Auto Tune Staging Speeds	{[0] Disabled, [1] Enabled}	[1] Enabled

Table 4.3

4.1.5 Staging/De-staging of Fixed Speed Pumps

Fixed speed pumps are staged based or de-staged based on system pressure.

To avoid rapid turning on and off of pumps, define an acceptable range of system pressure along with a period of time the pressure is allowed to be outside of this band before staging or de-staging occurs. Set the values through:

- 27-20 Normal Operating Range
- 27-23 Staging Delay
- 27-24 Destaging Delay

NOTICE

The parameters are installation dependent.

Automatic stage/de-stage threshold

The speed of the variable speed pump at the point of staging or de-staging is defined by stage or a de-stage threshold. These settings prevent overshoot or undershoot in the pressure at staging or de-staging.

The auto tune of staging and de-staging threshold monitors the feedback at the point of staging or de-staging and adjusts the settings every time a staging takes place.

Parameter	Range	Default
27-40 Auto Tune Staging Settings	{[0] Disabled, [1] Enabled}	[1] Enabled

Table 4.4

4.2 Operation

The configuration of the Cascade Controller is now completed.

- Enable/disable cascade control via through 27-10 Cascade Controller
- Power up the master drive

When the Cascade Controller is enabled it controls system pressure by varying the speed of the frequency converter and by staging pumps on and off.

Two stop functions are provided by the Cascade Controller. One function quickly stops the system. The other function de-stages pumps in a sequence, allowing for a pressure controlled stop. For the VLT® AQUA Drive equipped with Safe Stop, terminal 37 will turn off all relays and coast the master drive. If any of the digital inputs are set to [8] Start and the corresponding terminal is used to control start and stop of the frequency converter, then setting the terminal to 0 V will turn off all relays and coast the master drive. Pressing [Off] on the LCP will cause a sequenced de-staging of running pumps.

4.2.1 Pump Status and Control

Select parameter group 27-0* Control & Status to check on the status of the Cascade Controller and to control individual pumps. Select a specific pump to view the

current status, the current running hours and the total lifetime hours. Control individual pumps manually for maintenance purposes.

Parameter	Pump 1	Pump 2	Pump 3	Pump ...
27-01 Pump Status	On Drive	Ready	Offline-off	
27-02 Manual Pump Control	No Operation	No Operation	No Operation	
27-03 Current Runtime Hours	650	667	400	
27-04 Pump Total Lifetime Hours	52673	29345	30102	

Table 4.5

1. Navigate to parameter group 27-0* Control & Status
2. Press [◀] and [▶] on the LCP to select the pump.
3. Press [▲] and [▼] on the LCP to select the parameter.

4.2.2 Manual Pump Control

The Extended Cascade Controller allows for complete control of each pump in the system. Use 27-02 Manual Pump Control to control individual pumps through their relays.

This parameter differs from other value related parameters as selecting one of these options will cause the action to occur and then the parameter will revert back to its default state.

The choices are as follows:

- [0] No Operation - Default.
- [1] Online - Makes the pump available to the Extended Cascade Controller.
- [2] Alternate On - Forces the selected pump to be the lead pump.
- [3] Offline-Off - Turns the pump off and makes it unavailable for cascading.
- [4] Offline-On - Turns the pump on and makes it unavailable for cascading.
- [5] Offline-Spin - Initiates a pump spin.

If any of the "Offline" selections are chosen the pump will no longer be available to the Cascade Controller until "Online" is selected.

If a pump is taken offline through 27-02 Manual Pump Control, the cascade Controller attempts to compensate for the offline pumps as follows:

- If [3] *Offline-Off* is selected for a pump that is running, another pump will be staged on to compensate for the loss of output.
- If [4] *Offline-On* is selected for a pump that is off, another pump will be staged off to compensate for the excess output.

4.2.3 Runtime Balancing

The Extended Cascade Controller is designed to balance the running hours of the available pumps. *27-16 Runtime Balancing* provides a balancing priority for each pump in the system.

Three levels of priority are available:

- [0] Balanced Priority 1
- [1] Balanced Priority 2
- [2] Spare Pump

The Cascade Controller selects a pump to be staged or de-staged based on the pump's maximum capacity (*27-14 Pump Capacity*), *27-03 Current Runtime Hours* and *27-16 Runtime Balancing*.

During staging the Cascade Controller balances the current running hours for all pumps set to [0] *Balanced Priority 1* in *27-16 Runtime Balancing*.

If all priority 1 pumps are running, the Cascade Controller balances the pumps set to [1] *Balanced Priority 2* selected.

If all priority 1 and 2 pumps are running, pumps set to [2] *Spare Pump* are selected.

During de-staging the reverse occurs. Spare pumps are de-staged first, followed by Priority 2 pumps, followed by Priority 1 pumps. At each priority level the pump with the highest current runtime hours will be de-staged first.

NOTICE

In mixed pump configurations with more than one frequency converter all variable speed pumps are staged or de-staged before fixed speed pumps.

Choose *27-19 Reset Current Runtime Hours* to reset the current runtime hours and restart the balancing process. This parameter does not affect the Total Lifetime Hours (*27-04 Pump Total Lifetime Hours*) for each pump. Total Lifetime Hours is not used for runtime balancing.

4.2.4 Pump Spin for Unused Pumps

If a pump is only needed occasionally, the Cascade Controller balances the running hours of the pumps through alternation. If a pump is not used in 72 hours, a pump spin is triggered.

The spin time can be set with *27-18 Spin Time for Unused Pumps*. The Spin Time should be long enough to ensure that the pump stays in good working condition but short enough not to over pressure the system. Set *27-18 Spin Time for Unused Pumps* to zero to disable the function.

NOTICE

The Extended Cascade Controller does not compensate for the extra pressure generated during a pump spin. Keep the spin time as short as possible to prevent damage caused by over pressuring the output.

4.2.5 Total Lifetime Hours

The Extended Cascade Controller and the Advanced Cascade Controller keep track of the total lifetime hours for each controlled pump.

27-04 Pump Total Lifetime Hours displays a running total of the operating hours for each pump. The total lifetime hours are saved in the non-volatile memory once every hour.

This parameter can also be set to an initial value that reflects the hours of operation for a pump before it was added to the system.

NOTICE

Lifetime hours will only be recorded if the Cascade Controller is enabled and controlling the pump.

4.2.6 Alternation of the Lead Pump

In a configuration with multiple frequency converters, the lead pump is defined as the last variable speed pump running.

In a configuration with only a single frequency converter, the lead pump is defined as the pump connected to the frequency converter.

During start-up and normal staging/de-staging the Cascade Controller balances running hours by alternating the lead pump.

Alternation of lead pumps can also be forced manually e.g. through *27-54 Alternation At Time of Day* or through a digital input. Use alternation time parameters if the system

demand normally stays below the maximum capacity of the lead pump

4.2.7 Staging/De-staging in Mixed Pump Configurations

Two methods are used to decide when pumps should be staged or de-staged.

- Speed of the frequency converters
- Feedback pressure exceeding the normal operating range

In a mixed pump configuration with more than one frequency converter both methods are used. In the following example, feedback is referred to as pressure.

Staging

When the master drive receives a start command a variable speed pump is selected, and started using one of the available frequency converters.

If the system pressure drops, the speed of the frequency converter increases to meet the demand for more flow. While maintaining the pressure, if the frequency converter exceeds *27-31 Stage On Speed [RPM]* (or *27-32 Stage On Speed [Hz]*) and remains above that speed for *27-33 Stage Off Speed [RPM]* (or *27-34 Stage Off Speed [Hz]*) time, the next variable speed pump is staged on.

If the Cascade Controller is unable to maintain the system pressure with all variable speed pumps running at maximum, it will stage on fixed speed pumps. A fixed speed pump will be staged on when the pressure goes below the setpoint by *27-20 Normal Operating Range* percentage and stays there for the Staging Delay time (*27-23 Staging Delay*).

De-staging

If the system pressure increases, the speed of the frequency converter decreases to maintain pressure. If the frequency converter drops below *27-33 Stage Off Speed [RPM]* (or *27-32 Stage On Speed [Hz]*) and stays there for the time chosen in *27-24 Destaging Delay*, a variable speed pump will be staged off.

If the system pressure is too high with only one frequency converter running at minimum speed, it will de-stage fixed speed pumps. A fixed speed pump will be de-staged when the pressure goes above the setpoint in *27-20 Normal Operating Range* and stays there for the time chosen in *27-24 Destaging Delay*. If the system demand continues to drop the system will enter sleep mode.

4.2.8 Override Staging/De-staging

Normal staging and de-staging handles most of the situations in typical applications but the Cascade Controller in stage and de-stage pumps immediately in response to large changes in system demand.

Staging

When the system pressure drops below the override limit (*27-21 Override Limit*), the Cascade Controller will immediately stage on a pump to meet the demand for more flow.

If the system pressure continues to stay below *27-21 Override Limit* for *27-25 Override Hold Time*, the Cascade Controller will then stage on the next pump. This repeats until all pumps are on or until the system pressure drops below the Override Limit.

De-staging

When the system pressure exceeds *27-21 Override Limit*, the Cascade Controller immediately de-stages a pump to reduce the pressure.

If the system pressure continues to stay above *27-21 Override Limit* for *27-25 Override Hold Time*, the Cascade Controller de-stages another pump. This will repeat until only the lead pump is left on or until the pressure stabilizes.

27-21 Override Limit is set as a % of the Maximum Reference. It defines a point above and below the system Setpoint where Override staging and de-staging will occur.

4.2.9 Minimum Speed De-staging

To reduce emergency usage the Cascade Controller will de-stage a pump if the lead pump is running at minimum speed for *27-27 Min Speed Destage Delay*.

4.2.10 Fixed Speed only Operation

Fixed speed only operation keeps critical systems operating even if all variable speed pumps are unavailable to the Cascade Controller. In this situation, the Cascade Controller maintains system pressure by turning on and off fixed speed pumps.

Staging

If all the variable speed pumps are unavailable and the system pressure goes below *27-22 Fixed Speed Only Operating Range* for the Staging Delay time (*27-23 Staging Delay*), a fixed speed pump will be turned on.

De-staging

If all variable speed pumps are unavailable and the system pressure goes above 27-22 *Fixed Speed Only Operating Range* for the De-stage Delay time (27-24 *Destaging Delay*), a fixed speed pump will be turned off.

If the pressure feedback signal originates at the far end of the system, the frequency converter does not need to compensate for system pressure changes due to flow and the default feedback process can be used.

4.2.11 Flow Compensation for Applications with Cascade Controller

To place the pressure sensor close to the system output is not always an advantage. The frequency converter controls the pump speed to produce a constant pressure at the system outlet. The constant pressure ensures the required maximum flow. At reduced flow, the energy that went into producing this excess pressure is wasted.

The Flow Compensation feature adjusts the internal reference based on the number of pumps in operation. It uses the feedback to estimate the set-point required at various rates of flow. As *Illustration 4.3* shows, the calculation of the theoretical curve results in step wise adjusted set-points following this curve. Set-point 1 is the minimum pressure required when the system is running with only one pump operating and under minimum load conditions. Set-point 2 is used, when all pumps are running.

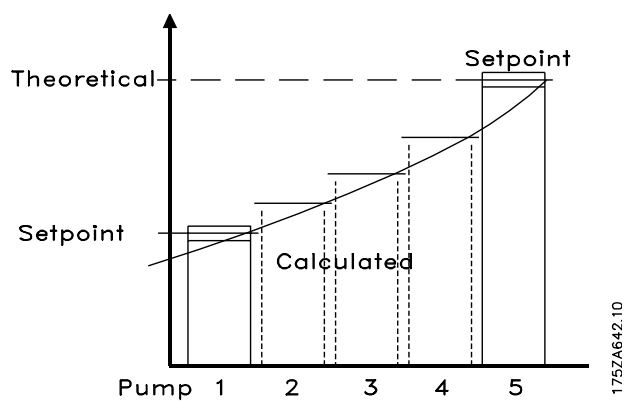

Illustration 4.3 Calculation of Theoretical Curve

The range of the curve is determined by the no/low flow point and the uncompensated set-point (e.g. in 20-21 *Setpoint 1*).

Besides configuration of the Cascade Controller, the required programming steps are:

- Enable Flow Compensation in 22-80 *Flow Compensation*
- Program the Pressure at No-Flow Speed in 22-87 *Pressure at No-Flow Speed*
- Program the uncompensated setpoint (e.g. in 20-21 *Setpoint 1*)

5 Parameter Descriptions

5.1 Cascade Controller Parameters

NOTICE

If one of the Cascade Controller options is used to extend the number of pumps in a Basic Cascade, the parameters in parameter group 25-** have to be used. See *VLT AQUA® Drive Programming Guide* for further information.

5

3-02 Minimum Reference		
Range:	Function:	
Size related* [-999999.999 - par. 3-03 ReferenceFeed-backUnit]	Enter the minimum reference. The minimum reference is the lowest value obtainable by summing all references. Minimum reference is active only when 3-00 Reference Range is set to [0] Min.- Max. The minimum reference unit matches: <ul style="list-style-type: none"> The configuration of 1-00 Configuration Mode Configuration Mode: for [1] Speed closed loop, RPM; for [2] Torque, Nm. The unit selected in 3-01 Reference/Feedback Unit. 	

3-03 Maximum Reference		
Range:	Function:	
Size related* [par. 3-02 - 999999.999 ReferenceFeed-backUnit]	Enter the Maximum Reference. The Maximum Reference is the highest value obtainable by summing all references. The Maximum Reference unit matches: <ul style="list-style-type: none"> The choice of configuration in 1-00 Configuration Mode: for [1] Speed closed loop, RPM; for [2] Torque, Nm. The unit selected in 3-00 Reference Range. 	

3-15 Reference 1 Source		
Option:	Function:	
	Select the reference input to be used for the first reference signal.	

3-15 Reference 1 Source		
Option:	Function:	
	3-15 Reference 1 Source, 3-16 Reference 2 Source and 3-17 Reference 3 Source define up to 3 different reference signals. The sum of these reference signals defines the actual reference.	
[0]	No function	
[1]	Analog input 53	
[2]	Analog input 54	
[7]	Pulse input 29	
[8]	Pulse input 33	
[20]	Digital pot.meter	
[21]	Analog input X30/11	(General Purpose I/O Option Module)
[22]	Analog input X30/12	(General Purpose I/O Option Module)
[23]	Analog Input X42/1	
[24]	Analog Input X42/3	
[25]	Analog Input X42/5	
[29]	Analog Input X48/2	
[30]	Ext. Closed Loop 1	
[31]	Ext. Closed Loop 2	
[32]	Ext. Closed Loop 3	

3-16 Reference 2 Source		
Option:	Function:	
	Select the reference input to be used for the second reference signal. 3-15 Reference 1 Source, 3-16 Reference 2 Source and 3-17 Reference 3 Source define up to 3 different reference signals. The sum of these reference signals defines the actual reference.	
[0]	No function	
[1]	Analog input 53	
[2]	Analog input 54	
[7]	Pulse input 29	
[8]	Pulse input 33	
[20]	Digital pot.meter	
[21]	Analog input X30/11	
[22]	Analog input X30/12	
[23]	Analog Input X42/1	
[24]	Analog Input X42/3	
[25]	Analog Input X42/5	
[29]	Analog Input X48/2	
[30]	Ext. Closed Loop 1	
[31]	Ext. Closed Loop 2	
[32]	Ext. Closed Loop 3	

3-17 Reference 3 Source		
Option:	Function:	
		Select the reference input to be used for the third reference signal. <i>3-15 Reference 1 Source, 3-16 Reference 2 Source and 3-17 Reference 3 Source</i> define up to 3 different reference signals. The sum of these reference signals defines the actual reference.
[0]	No function	
[1]	Analog input 53	
[2]	Analog input 54	
[7]	Pulse input 29	
[8]	Pulse input 33	
[20]	Digital pot.meter	
[21]	Analog input X30/11	
[22]	Analog input X30/12	
[23]	Analog Input X42/1	
[24]	Analog Input X42/3	
[25]	Analog Input X42/5	
[29]	Analog Input X48/2	
[30]	Ext. Closed Loop 1	
[31]	Ext. Closed Loop 2	
[32]	Ext. Closed Loop 3	

5-01 Terminal 27 Mode		
Option:	Function:	
		NOTICE This parameter cannot be adjusted while the motor is running.
[0]	Input	Defines terminal 27 as a digital input.
[1]	Output	Defines terminal 27 as a digital output.

5-13 Terminal 29 Digital Input		
Option:	Function:	
		Select the function from the available digital input range and the additional options [60], [61], [63] and [64]. Counters are used in Smart Logic Control functions. This parameter is available for FC 302 only.
[14] *	Jog	Functions are described under parameter group 5-1* <i>Digital Inputs</i>

5-30 Terminal 27 Digital Output		
Option:	Function:	
[0]	No operation	
[1]	Control ready	
[2]	Drive ready	
[3]	Drive rdy/rem ctrl	
[4]	Stand-by / no warning	
[5]	Running	
[6]	Running / no warning	
[8]	Run on ref/no warn	
[9]	Alarm	

5-30 Terminal 27 Digital Output		
Option:	Function:	
[10]	Alarm or warning	
[11]	At torque limit	
[12]	Out of current range	
[13]	Below current, low	
[14]	Above current, high	
[15]	Out of speed range	
[16]	Below speed, low	
[17]	Above speed, high	
[18]	Out of feedb. range	
[19]	Below feedback, low	
[20]	Above feedback, high	
[21]	Thermal warning	
[25]	Reverse	
[26]	Bus OK	
[27]	Torque limit & stop	
[28]	Brake, no brake war	
[29]	Brake ready, no fault	
[30]	Brake fault (IGBT)	
[35]	External Interlock	
[40]	Out of ref range	
[41]	Below reference, low	
[42]	Above ref, high	
[45]	Bus ctrl.	
[46]	Bus ctrl, 1 if timeout	
[47]	Bus ctrl, 0 if timeout	
[55]	Pulse output	
[60]	Comparator 0	
[61]	Comparator 1	
[62]	Comparator 2	
[63]	Comparator 3	
[64]	Comparator 4	
[65]	Comparator 5	
[70]	Logic rule 0	
[71]	Logic rule 1	
[72]	Logic rule 2	
[73]	Logic rule 3	
[74]	Logic rule 4	
[75]	Logic rule 5	
[80]	SL digital output A	
[81]	SL digital output B	
[82]	SL digital output C	
[83]	SL digital output D	
[84]	SL digital output E	
[85]	SL digital output F	
[160]	No alarm	
[161]	Running reverse	
[165]	Local ref active	
[166]	Remote ref active	
[167]	Start command act.	
[168]	Hand mode	
[169]	Auto mode	
[180]	Clock Fault	

5-30 Terminal 27 Digital Output		
Option:	Function:	
[181]	Prev. Maintenance	
[182]	Deragging	
[188]	AHF Capacitor Connect	
[189]	External Fan Control	
[190]	No-Flow	
[191]	Dry Pump	
[192]	End Of Curve	
[193]	Sleep Mode	
[194]	Broken Belt	
[195]	Bypass Valve Control	
[198]	Drive Bypass	
[199]	Pipe Filling	
[200]	Full capacity	
[201]	Pump 1 running	
[202]	Pump 2 running	
[203]	Pump 3 running	
[204]	Pump 4 running	
[205]	Pump 5 running	
[206]	Pump 6 running	
[207]	Pump 7 running	
[208]	Pump 8 running	
[209]	Pump 9 running	

5-50 Term. 29 Low Frequency		
Range:	Function:	
100 Hz*	[0 - 110000 Hz]	Enter the low frequency limit corresponding to the low motor shaft speed (i.e. low reference value) in 5-52 Term. 29 Low Ref./Feedb. Value. Refer to . This parameter is available for FC 302 only.

5-51 Term. 29 High Frequency		
Range:	Function:	
100 Hz*	[0 - 110000 Hz]	Enter the high frequency limit corresponding to the high motor shaft speed (i.e. high reference value) in 5-53 Term. 29 High Ref./Feedb. Value. This parameter is available for FC 302 only.

5-52 Term. 29 Low Ref./Feedb. Value		
Range:	Function:	
0.000 *	[-999999.999 - 999999.999]	Enter the low reference value limit for the motor shaft speed [RPM]. This is also the lowest feedback value, see also 5-57 Term. 33 Low Ref./Feedb. Value. Set terminal 29 to digital input (5-02 Terminal 29 Mode = [0] input (default) and 5-13 Terminal 29 Digital Input = applicable value).

5-52 Term. 29 Low Ref./Feedb. Value		
Range:	Function:	
		This parameter is available for FC 302 only.

5-53 Term. 29 High Ref./Feedb. Value		
Range:	Function:	
100 *	[-999999.999 - 999999.999]	Enter the high reference value [RPM] for the motor shaft speed and the high feedback value, see also 5-58 Term. 33 High Ref./Feedb. Value.

5-54 Pulse Filter Time Constant #29		
Range:	Function:	
100 ms*	[1 - 1000 ms]	Enter the pulse filter time constant. The pulse filter dampens oscillations of the feedback signal, which is an advantage, if there is a lot of noise in the system. A high time constant value results in better dampening but also increases the time delay through the filter.

5-60 Terminal 27 Pulse Output Variable		
Option:	Function:	
[0]	No operation	Select the desired display output for terminal 27.
[45]	Bus ctrl.	
[48]	Bus ctrl., timeout	
[100]	Output freq. 0-100	
[101]	Reference Min-Max	
[102]	Feedback +-200%	
[103]	Motor cur. 0-Imax	
[104]	Torque 0-Tlim	
[105]	Torque 0-Tnom	
[106]	Power 0-Pnom	
[107]	Speed 0-HighLim	
[108]	Torque +-160%	
[109]	Out frq 0-Fmax	
[113]	Ext. Closed Loop 1	
[114]	Ext. Closed Loop 2	
[115]	Ext. Closed Loop 3	
[116]	Cascade Reference	

5-62 Pulse Output Max Freq #27		
Range:	Function:	
5000 Hz*	[0 - 32000 Hz]	Set the maximum frequency for terminal 27, corresponding to the output variable selected in 5-60 Terminal 27 Pulse Output Variable.

5.1.1 Cascade CTL Option, 27-**

Cascade Control Option parameter group.

5.1.2 Array Parameters

For the following parameters the index is referring to the number of the (specific) pump. In case of the Stage On/Off Speeds, the index reflects the number of pumps in operation.

- 27-01 Pump Status
- 27-02 Manual Pump Control
- 27-03 Current Runtime Hours
- 27-04 Pump Total Lifetime Hours
- 27-14 Pump Capacity
- 27-16 Runtime Balancing
- 27-31 Stage On Speed [RPM]
- 27-32 Stage On Speed [Hz]
- 27-33 Stage Off Speed [RPM]
- 27-34 Stage Off Speed [Hz]

NOTICE

For 27-70 Relay, index 0 refers to relay 1, index 1 refers to relay 2, index 2 refers to relay 3 ... index 19 refers to relay 20.

5.1.3 Control & Status, 27-0*

Control and status parameters are for monitoring and manual control of the pumps.

Press [◀] and [▶] keys to choose pump. Press [▲] and [▼] keys to change settings.

27-01 Pump Status		
Pump Status is a readout parameter showing the status of each pump in the system.		
Option:		Function:
[0]	Ready	The pump is available for use by the Cascade Controller.
[1]	On Drive	The pump is controlled by the Cascade Controller, and the pump is connected to a frequency converter, and is running.
[2]	On Mains	The pump is controlled by the Cascade Controller, and the pump is connected to mains, and is running.
[3]	Offline - Off	The pump is not available for use by the Cascade Controller, and the pump is off.
[4]	Offline - On Mains	The pump is not available for use by the Cascade Controller, and the pump is connected to mains and is running
[5]	Offline - On Drive	The pump is not available for use by the Cascade Controller, and the pump is connected to mains and is running

27-01 Pump Status		
Pump Status is a readout parameter showing the status of each pump in the system.		
Option:		Function:
[6]	Offline - Fault	The pump is not available for use by the Cascade Controller, and the pump is connected to mains and is running
[7]	Offline - Hand	The pump is not available for use by the Cascade Controller, and the pump is connected to mains and is running
[8]	Offline - External Interlock	The pump has been externally interlocked and is off.
[9]	Spinning	The cascade control is executing a spin cycle for the pump.
[10]	No Relay Connection	The pump is not directly connected to a frequency converter, and no relay has been assigned to the pump

27-02 Manual Pump Control		
Manual Pump Control is a command parameter that allows manual control of individual pump states. Selecting one of these will execute the command and then return to No Operation.		
Option:		Function:
[0]	No Operation	Does nothing.
[1]	Online	Makes the pump available to the Cascade Controller.
[2]	Alternate On	Forces the selected pump to be the lead pump.
[3]	Offline - Off	Turns the pump off and makes the pump unavailable for cascading.
[4]	Offline - On	Turns the pump on and makes the pump unavailable for cascading.
[5]	Offline - Spin	Initiates a pump spin.

27-03 Current Runtime Hours		
Range:		Function:
0 h*	[0 - 2147483647 h]	Current Runtime Hours is a readout parameter showing the total number of hours each pump has been running since last reset. This time is used to balance the running hours between pumps. The times may all be reset to 0 using 27-91 Cascade Reference.

27-04 Pump Total Lifetime Hours		
Range:		Function:
0 h*	[0 - 2147483647 h]	Pump Total Lifetime Hours is the total operating hours for each connected pump.

NOTICE

This parameter may be individually set to any value for maintenance purposes.

5.1.4 Configuration, 27-1*

This parameter group is for configuring the Cascade Controller option.

27-10 Cascade Controller		
Cascade Controller Mode sets the operating mode.		
Option:	Function:	
[0]	Disabled	
[1]	Master/Follower	
[2]	Mixed Pumps	
[3]	Basic Cascade Ctrl	

27-11 Number Of Drives		
Range:	Function:	
Size related*	[1 - 8]	Number of frequency converters to be controlled by the Cascade Controller. MCO 101: 1-6 MCO 102: 1-8

27-12 No. of Pumps		
Range:	Function:	
0*	[0 - No. of Drives]	Number of Pumps to be controlled by the Cascade Controller. MCO 101: 0-6 MCO 102: 0-8

27-14 Pump Capacity		
Range:	Function:	
100 %*	[10 - 800 %]	Pump Capacity sets the capacity of each pump in the system relative to the first pump. This is an indexed parameter with one entry per pump. The capacity of the first pump is always considered to be 100%.

27-16 Runtime Balancing		
Runtime Balancing sets the priority of each pump for balancing it's running hours. The pumps with the highest priority will be operated before the lower prioritised pumps. Pumps with the same priority are staged/de-staged based on the running hours.		
Option:	Function:	
[0]	Balanced Priority 1	Turned on first, turned off last.
[1]	Balanced Priority 2	Turned on if no priority 1 pumps are available. Turned off before priority 1 pumps are turned off.
[2]	Spare Pump	Turned on last, turned off first.

27-17 Motor Starters		
Option:	Function:	
		Motor Starters selects the type of mains starters used on the fixed speed pumps. All fixed speed pumps must be configured the same. Possible choices are:
[0]	Direct Online	
[1]	Soft Starter	Adds a delay when staging and de-staging corresponding to the soft-starter ramp time, see parameter 27-41 and 27-42.
[2]	Star/Delta	Adds a delay at staging, controlled by 27-42 Ramp Up Delay.

27-18 Spin Time for Unused Pumps		
Range:	Function:	
Size related*	[0 - 99 s]	Spin Time for Unused Pumps sets the length of time to spin unused pumps. If a fixed speed pump has not been run in the last 72 hours, it will be turned on for this time. This is to prevent damage caused by leaving the pump off too long. The spin feature may be disabled by setting the value of this parameter to 0.

CAUTION

Setting this parameter too high may cause overpressure to some systems.

27-19 Reset Current Runtime Hours		
Reset Current Runtime Hours is used to reset all Current Runtime Hours to zero. This time is used for runtime balancing.		
Option:	Function:	
[0]	Do not reset	
[1]	Do reset	

5.1.5 Bandwidth Settings, 27-2*

Parameters for configuring control response.

27-20 Normal Operating Range		
Range:	Function:	
Size related*	[1 - 100 %]	Normal Operating Range is the allowed offset from the set-point before a pump may be added or removed. The system must be outside this limit for the time specified in 27-23 Staging Delay or 27-24 Destaging Delay before a cascade operation takes place. Normal refers to the system operating with at least one variable speed pump available. This value is entered as a % of Max Reference, see 21-12 Ext. 1 Maximum Reference in the VLT® AQUA Drive Programming Guide for further information.

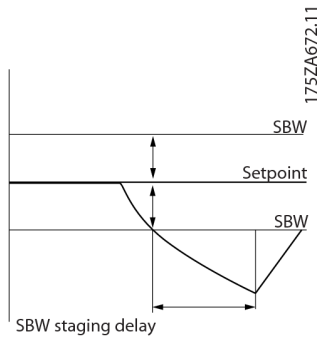

Illustration 5.1

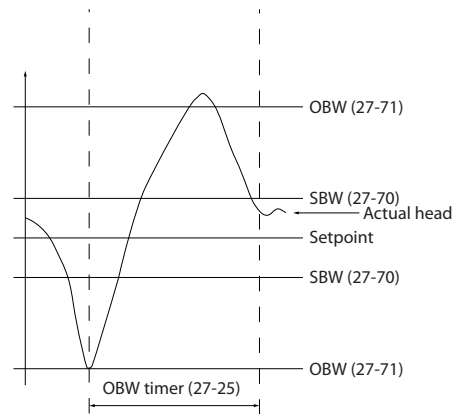

Illustration 5.3

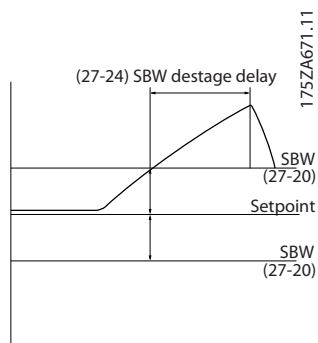

Illustration 5.2

27-21 Override Limit		
Range:	Function:	
100 %*	[0 - 100 %]	Override Limit is the allowed offset from the set-point before a pump will immediately be added or removed (for instance in case of a fire tab is switched on). Normal Operating Range includes a delay that limits the system response to transients. This makes the system respond too slowly to large demand changes. The override limit causes the frequency converter to respond immediately. The value is entered as a % of Max Reference (21-12 Ext. 1 Maximum Reference). Override operation may be disabled by setting this parameter to 100%.

NOTICE

In master-follower applications the override limit is used as wake-up condition. See 6.1 Master/Follower for further information.

27-22 Fixed Speed Only Operating Range		
Range:	Function:	
Size related*	[0 - par. 27-21 %]	Fixed Speed Only Operating Range is the allowed offset from the set-point before a pump may be added or removed when there are no operational variable speed pumps. The system must be outside this limit for the time specified in 27-23 Staging Delay or 27-24 Destaging Delay before a cascade operation may take place. The value is entered as a % of Max Reference. When there are no operational variable speed pumps, the system will try to maintain control with the remaining fixed speed pumps.

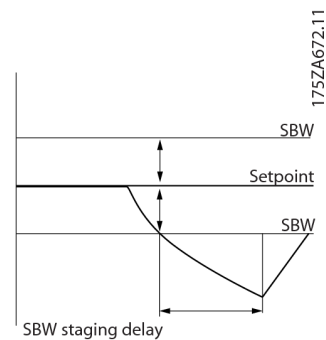

Illustration 5.4

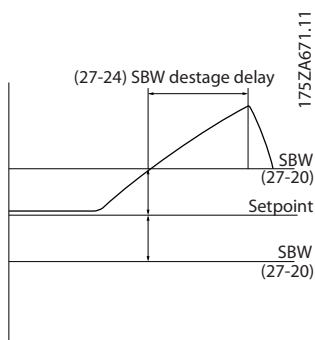

Illustration 5.5

27-23 Staging Delay		
Range:	Function:	
15 s*	[0 - 3000 s]	Staging Delay is the time that the system feedback must remain below the operating range before a pump may be turned on. If the system is operating with at least one variable speed pump available, <i>27-20 Normal Operating Range</i> is used. If there are no variable speed pumps available, <i>27-22 Fixed Speed Only Operating Range</i> is used.

27-24 Destaging Delay		
Range:	Function:	
15 s*	[0 - 3000 s]	De-staging Delay is the time that the system feedback must remain above the operating range before a pump may be turned off. If the system is operating with at least one variable speed pump available, the <i>Normal Operating Range (27-20 Normal Operating Range)</i> is used. If there are no variable speed pumps available <i>27-22 Fixed Speed Only Operating Range</i> is used.

27-25 Override Hold Time		
Range:	Function:	
10 s*	[0 - 300 s]	Override Hold Time is the minimum time that must elapse after a stage or de-stage before a stage or de-stage may take place due to the system exceeding the Override Limit (parameter 27-21). The override hold time is designed to allow the system to stabilize after a pump is turned on or off. If this delay is not long enough, the transients caused by turning a pump on or off may cause the system to add or remove another pump when it should not.

27-27 Min-Speed De-stage Delay		
Range:	Function:	
15 s*	[0 - 300 s]	Min-Speed De-stage Delay is the time that the lead pump must be running at minimum speed while the system feedback is still inside the normal operating band before a pump will be turned off to save energy. Energy savings may be

27-27 Min-Speed De-stage Delay		
Range:	Function:	
		realized by turning off a pump if the variable speed pumps are operating at minimum speed but the feedback is still in band. Under these conditions, a pump may be turned off and the system will still be able to maintain control. The pumps that remain on will then be operating more efficiently.

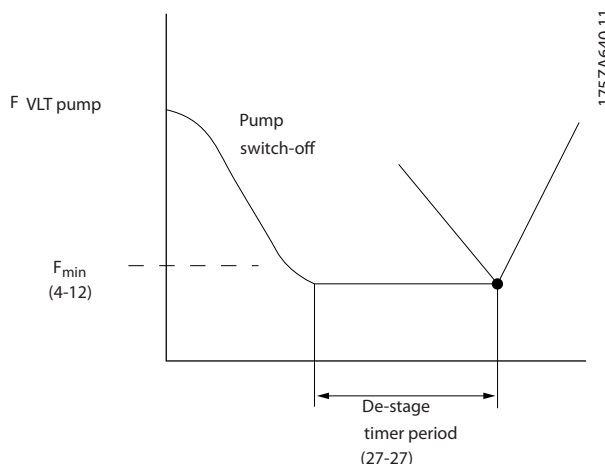

Illustration 5.6

5.1.6 Staging Speed, 27-3*

Parameters for configuring Master/Follower control response.

27-30 Auto Tune Staging Speeds		
Option:	Function:	
[0]	Disabled	
[1]	Enabled	When parameter 27-30 is [1] <i>Enabled</i> , parameters 27-31, 27-32, 27-33 and 27-34 will be kept up to date with new automatically calculated values. If <i>27-31 Stage On Speed [RPM]</i> , <i>27-32 Stage On Speed [Hz]</i> , <i>27-33 Stage Off Speed [RPM]</i> and <i>27-34 Stage Off Speed [Hz]</i> are modified from the bus or LCP, then the new values will be used but will continue to be automatically tuned. Values will be recalculated and the parameters updated when staging occurs.

When enabled the stage on and off speeds will continually be auto tuned during operation. The settings will be optimized in order to ensure a high performance and low energy consumption.

27-31 Stage On Speed [RPM]		
Range:	Function:	
Size related*	[0 - par. 4-13 RPM]	To be used if RPM is chosen. If the lead pump is operating above Stage On Speed for the time specified

27-31 Stage On Speed [RPM]		
Range:	Function:	
	in 27-23 <i>Staging Delay</i> and a variable speed pump is available, it will be turned on.	

27-34 Stage Off Speed [Hz]		
Range:	Function:	
	27-24 <i>Destaging Delay</i> and more than one variable speed pump is on, a variable speed pump will be turned off.	

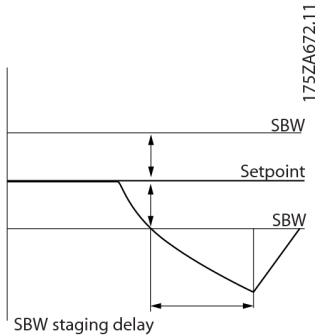

Illustration 5.7

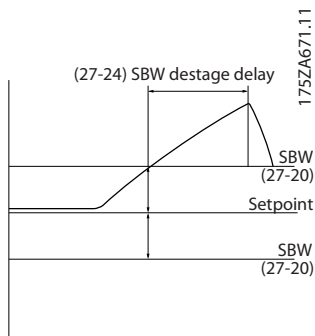

Illustration 5.8

27-32 Stage On Speed [Hz]		
Range:	Function:	
Size related*	[0 - par. 4-14 Hz]	To be used if Hz is chosen. If the lead pump is operating above Stage On Speed for the time specified in 27-23 <i>Staging Delay</i> and a variable speed pump is available, it will be turned on.

27-33 Stage Off Speed [RPM]		
Range:	Function:	
Size related*	[0 - 1500 RPM]	If the lead pump is operating below Stage Off Speed for the time specified in 27-24 <i>Destaging Delay</i> and more than one variable speed pump is on, a variable speed pump will be turned off.

27-34 Stage Off Speed [Hz]		
Range:	Function:	
Size related*	[0.0 - 50 Hz]	If the lead pump is operating below Stage Off Speed for the time specified in

5.1.7 Staging Settings, 27-4*

Parameters for configuring staging transitions.

27-40 Auto Tune Staging Settings		
When enabled the staging and de-staging threshold will be auto tuned during operation. The settings will be optimized in order to prevent pressure over and undershoots when staging and de-staging.		
Option:	Function:	
[0]	Disabled	Staging or de-staging threshold.
[1]	Enabled	

27-41 Ramp Down Delay		
Range:	Function:	
10 s*	[0 - 120 s]	Ramp Down Delay sets the delay between turning on a soft starter controlled pump and ramping down the frequency converter controlled pump. This is only used for soft starter and star/delta controlled pumps.

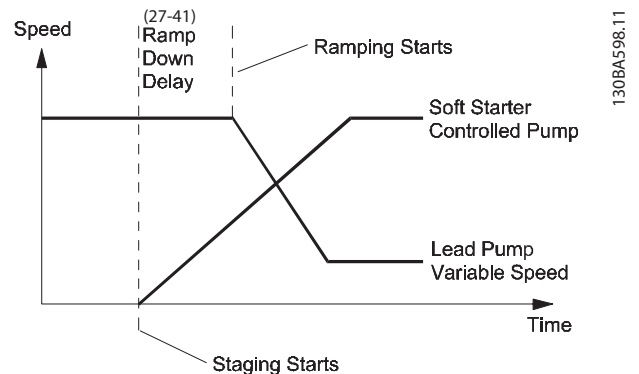

Illustration 5.9

NOTICE

Also used in star/delta pumps.

27-42 Ramp Up Delay		
Range:	Function:	
2 s*	[0 - 12 s]	Sets the delay between turning off a soft starter controlled pump and ramping up the frequency converter controlled pump. This is only used for soft starter controlled pumps.

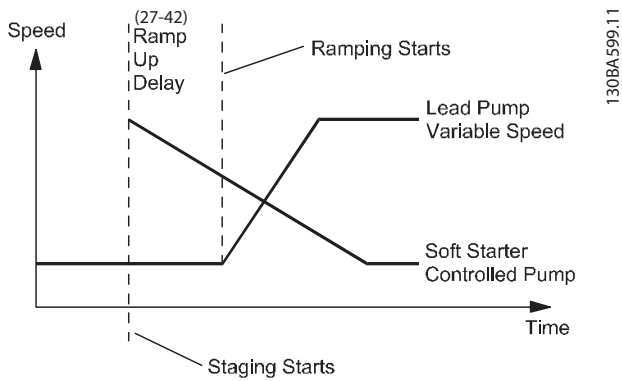

Illustration 5.10

5

NOTICE

Not used with star/delta controlled pumps.

27-43 Staging Threshold		
Range:	Function:	
Size related* [0 - 100 %]	Staging Threshold is the speed in the staging ramp at which the fixed speed pump should be turned on. Set as a percentage [%] of maximum pump speed.	
	If 27-40 Auto Tune Staging Settings is [1] Enabled, 27-43 Staging Threshold and 27-44 Destaging Threshold will be kept up to date with new automatically calculated values. If 27-43 Staging Threshold and 27-44 Destaging Threshold are modified from the bus or LCP, then the new values will be used, but will continue to be automatically tuned.	

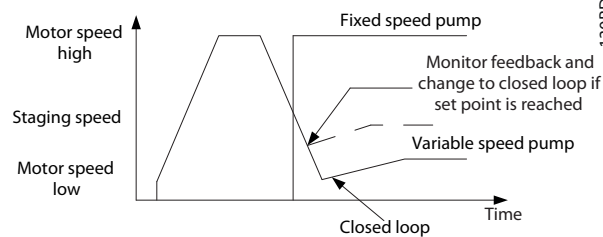

Illustration 5.11

27-44 Destaging Threshold		
Range:	Function:	
Size related* [0 - 100 %]	De-staging Threshold is the speed in the staging ramp at which the fixed speed pump should be turned on. Set as a percentage [%] of maximum pump speed.	
	If 27-40 Auto Tune Staging Settings is [1] Enabled will be kept up to date with new automatically calculated values. If 27-43 Staging Threshold and 27-44 Destaging	

27-44 Destaging Threshold		
Range:	Function:	
	Threshold are modified from the bus or LCP, then the new values will be used, but will continue to be automatically tuned.	

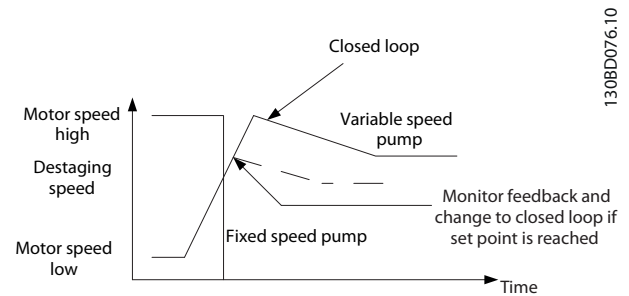

Illustration 5.12

27-45 Staging Speed [RPM]		
Range:	Function:	
0 RPM* [0 - 0 RPM]	Staging Speed is a readout parameter that shows the actual staging speed based on the staging threshold.	

27-46 Staging Speed [Hz]		
Range:	Function:	
0 Hz* [0 - 0 Hz]	Staging Speed is a readout parameter that shows the actual staging speed based on the staging threshold.	

27-47 Destaging Speed [RPM]		
Range:	Function:	
0 RPM* [0 - 0 RPM]	De-staging Speed is a readout parameter that shows the actual de-staging speed based on the de-staging threshold.	

27-48 Destaging Speed [Hz]		
Range:	Function:	
0 Hz* [0 - 0 Hz]	Destaging Speed is a readout parameter that shows the actual destaging speed based on the destaging threshold.	

5.1.8 Alternation Settings, 27-5*

Parameters for configuring alternations.

27-51 Alternation Event		
Option:	Function:	
[0]	Off	
[1]	At Destage	

27-52 Alternation Time Interval		
Range:		Function:
0 min*	[0 - 10080 min]	Alternation Time Interval is the user settable time between alternations. It is disabled by setting it to 0. 27-53 Alternation Timer Value shows the time remaining until the next alternation occurs.

27-53 Alternation Timer Value		
Range:		Function:
0 min*	[0 - 10080 min]	Alternation Timer Value is a readout parameter that shows the time remaining before an interval based alternation takes place. 27-52 Alternation Time Interval sets the time interval

27-54 Alternation At Time of Day		
Alternate at Time of Day allows selecting a specific time of day for alternating pumps. The time is set in parameter 27-55. Alternation at Time of Day requires the real time clock to be set.		
Option:		Function:
[0]	Disabled	
[1]	Enabled	

27-55 Alternation Predefined Time		
Range:		Function:
Size related*	[0 - 0]	Alternation Predefined Time is the time of day for pump alternation. This parameter is only available if 27-54 Alternation At Time of Day is set to Time of Day.

27-56 Alternate Capacity is <		
Range:		Function:
0 %*	[0 - 100 %]	Alternate Capacity is < requires the lead pump to be operating below this capacity before time based alternation will be allowed to take place. This feature ensures that alternation only takes place when the pump is running below a speed where interruption in operation will not affect the process. This minimizes the system disturbance caused by alternations. The value is entered as a % of the capacity of pump 1. Alternate Capacity is < operation may be disabled by setting this parameter to 0%.

27-58 Run Next Pump Delay		
Range:		Function:
0.1 s*	[0.1 - 5 s]	Run Next Pump Delay is a delay between stopping the current lead pump and starting the next lead pump when alternating lead pumps. This provides time for the contactors to switch while both pumps are stopped.

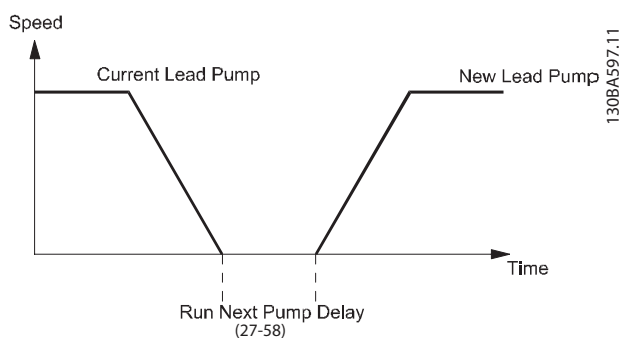

Illustration 5.13

5.1.9 Digital Inputs, 27-6*

27-60 Terminal X66/1 Digital Input		
Option:	Function:	
[0]	No operation	
[1]	Reset	
[2]	Coast inverse	
[3]	Coast and reset inv	
[5]	DC-brake inverse	
[6]	Stop inverse	
[7]	External interlock	
[8]	Start	
[9]	Latched start	
[10]	Reversing	
[11]	Start reversing	
[14]	Jog	
[15]	Preset reference on	
[16]	Preset ref bit 0	
[17]	Preset ref bit 1	
[18]	Preset ref bit 2	
[19]	Freeze reference	
[20]	Freeze output	
[21]	Speed up	
[22]	Speed down	
[23]	Set-up select bit 0	
[24]	Set-up select bit 1	
[34]	Ramp bit 0	
[36]	Mains failure inverse	
[51]	Hand/Auto Start	
[52]	Run permissive	
[53]	Hand start	
[54]	Auto start	
[55]	DigiPot increase	
[56]	DigiPot decrease	
[57]	DigiPot clear	
[62]	Reset Counter A	
[65]	Reset Counter B	
[66]	Sleep Mode	
[78]	Reset Preventive Maintenance Word	
[80]	PTC Card 1	
[85]	Latched Pump Derag	

27-60 Terminal X66/1 Digital Input		
Option:	Function:	
[120]	Lead Pump Start	
[121]	Lead Pump Alternation	
[130]	Pump 1 Interlock	
[131]	Pump 2 Interlock	
[132]	Pump 3 Interlock	
[133]	Pump 4 Interlock	
[134]	Pump 5 Interlock	
[135]	Pump 6 Interlock	
[136]	Pump 7 Interlock	
[137]	Pump 8 Interlock	
[138]	Pump 9 Interlock	

27-61 Terminal X66/3 Digital Input		
Option:	Function:	
[0]	No operation	
[1]	Reset	
[2]	Coast inverse	
[3]	Coast and reset inv	
[5]	DC-brake inverse	
[6]	Stop inverse	
[7]	External interlock	
[8]	Start	
[9]	Latched start	
[10]	Reversing	
[11]	Start reversing	
[14]	Jog	
[15]	Preset reference on	
[16]	Preset ref bit 0	
[17]	Preset ref bit 1	
[18]	Preset ref bit 2	
[19]	Freeze reference	
[20]	Freeze output	
[21]	Speed up	
[22]	Speed down	
[23]	Set-up select bit 0	
[24]	Set-up select bit 1	
[34]	Ramp bit 0	
[36]	Mains failure inverse	
[51]	Hand/Auto Start	
[52]	Run permissive	
[53]	Hand start	
[54]	Auto start	
[55]	DigiPot increase	
[56]	DigiPot decrease	
[57]	DigiPot clear	
[62]	Reset Counter A	
[65]	Reset Counter B	
[66]	Sleep Mode	
[78]	Reset Preventive Maintenance Word	
[80]	PTC Card 1	
[85]	Latched Pump Derag	
[120]	Lead Pump Start	

27-61 Terminal X66/3 Digital Input		
Option:	Function:	
[121]	Lead Pump Alternation	
[130]	Pump 1 Interlock	
[131]	Pump 2 Interlock	
[132]	Pump 3 Interlock	
[133]	Pump 4 Interlock	
[134]	Pump 5 Interlock	
[135]	Pump 6 Interlock	
[136]	Pump 7 Interlock	
[137]	Pump 8 Interlock	
[138]	Pump 9 Interlock	

27-62 Terminal X66/5 Digital Input		
Option:	Function:	
[0]	No operation	
[1]	Reset	
[2]	Coast inverse	
[3]	Coast and reset inv	
[5]	DC-brake inverse	
[6]	Stop inverse	
[7]	External interlock	
[8]	Start	
[9]	Latched start	
[10]	Reversing	
[11]	Start reversing	
[14]	Jog	
[15]	Preset reference on	
[16]	Preset ref bit 0	
[17]	Preset ref bit 1	
[18]	Preset ref bit 2	
[19]	Freeze reference	
[20]	Freeze output	
[21]	Speed up	
[22]	Speed down	
[23]	Set-up select bit 0	
[24]	Set-up select bit 1	
[34]	Ramp bit 0	
[36]	Mains failure inverse	
[51]	Hand/Auto Start	
[52]	Run permissive	
[53]	Hand start	
[54]	Auto start	
[55]	DigiPot increase	
[56]	DigiPot decrease	
[57]	DigiPot clear	
[62]	Reset Counter A	
[65]	Reset Counter B	
[66]	Sleep Mode	
[78]	Reset Preventive Maintenance Word	
[80]	PTC Card 1	
[85]	Latched Pump Derag	
[120]	Lead Pump Start	
[121]	Lead Pump Alternation	

27-62 Terminal X66/5 Digital Input		
Option:	Function:	
[130]	Pump 1 Interlock	
[131]	Pump 2 Interlock	
[132]	Pump 3 Interlock	
[133]	Pump 4 Interlock	
[134]	Pump 5 Interlock	
[135]	Pump 6 Interlock	
[136]	Pump 7 Interlock	
[137]	Pump 8 Interlock	
[138]	Pump 9 Interlock	

27-63 Terminal X66/7 Digital Input		
Option:	Function:	
[0]	No operation	
[1]	Reset	
[2]	Coast inverse	
[3]	Coast and reset inv	
[5]	DC-brake inverse	
[6]	Stop inverse	
[7]	External interlock	
[8]	Start	
[9]	Latched start	
[10]	Reversing	
[11]	Start reversing	
[14]	Jog	
[15]	Preset reference on	
[16]	Preset ref bit 0	
[17]	Preset ref bit 1	
[18]	Preset ref bit 2	
[19]	Freeze reference	
[20]	Freeze output	
[21]	Speed up	
[22]	Speed down	
[23]	Set-up select bit 0	
[24]	Set-up select bit 1	
[34]	Ramp bit 0	
[36]	Mains failure inverse	
[51]	Hand/Auto Start	
[52]	Run permissive	
[53]	Hand start	
[54]	Auto start	
[55]	DigiPot increase	
[56]	DigiPot decrease	
[57]	DigiPot clear	
[62]	Reset Counter A	
[65]	Reset Counter B	
[66]	Sleep Mode	
[78]	Reset Preventive Maintenance Word	
[80]	PTC Card 1	
[85]	Latched Pump Derag	
[120]	Lead Pump Start	
[121]	Lead Pump Alternation	
[130]	Pump 1 Interlock	

27-63 Terminal X66/7 Digital Input		
Option:	Function:	
[131]	Pump 2 Interlock	
[132]	Pump 3 Interlock	
[133]	Pump 4 Interlock	
[134]	Pump 5 Interlock	
[135]	Pump 6 Interlock	
[136]	Pump 7 Interlock	
[137]	Pump 8 Interlock	
[138]	Pump 9 Interlock	

27-64 Terminal X66/9 Digital Input		
Option:	Function:	
[0]	No operation	
[1]	Reset	
[2]	Coast inverse	
[3]	Coast and reset inv	
[5]	DC-brake inverse	
[6]	Stop inverse	
[7]	External interlock	
[8]	Start	
[9]	Latched start	
[10]	Reversing	
[11]	Start reversing	
[14]	Jog	
[15]	Preset reference on	
[16]	Preset ref bit 0	
[17]	Preset ref bit 1	
[18]	Preset ref bit 2	
[19]	Freeze reference	
[20]	Freeze output	
[21]	Speed up	
[22]	Speed down	
[23]	Set-up select bit 0	
[24]	Set-up select bit 1	
[34]	Ramp bit 0	
[36]	Mains failure inverse	
[51]	Hand/Auto Start	
[52]	Run permissive	
[53]	Hand start	
[54]	Auto start	
[55]	DigiPot increase	
[56]	DigiPot decrease	
[57]	DigiPot clear	
[62]	Reset Counter A	
[65]	Reset Counter B	
[66]	Sleep Mode	
[78]	Reset Preventive Maintenance Word	
[80]	PTC Card 1	
[85]	Latched Pump Derag	
[120]	Lead Pump Start	
[121]	Lead Pump Alternation	
[130]	Pump 1 Interlock	
[131]	Pump 2 Interlock	

27-64 Terminal X66/9 Digital Input		
Option:	Function:	
[132]	Pump 3 Interlock	
[133]	Pump 4 Interlock	
[134]	Pump 5 Interlock	
[135]	Pump 6 Interlock	
[136]	Pump 7 Interlock	
[137]	Pump 8 Interlock	
[138]	Pump 9 Interlock	

27-65 Terminal X66/11 Digital Input		
Option:	Function:	
[0]	No operation	
[1]	Reset	
[2]	Coast inverse	
[3]	Coast and reset inv	
[5]	DC-brake inverse	
[6]	Stop inverse	
[7]	External interlock	
[8]	Start	
[9]	Latched start	
[10]	Reversing	
[11]	Start reversing	
[14]	Jog	
[15]	Preset reference on	
[16]	Preset ref bit 0	
[17]	Preset ref bit 1	
[18]	Preset ref bit 2	
[19]	Freeze reference	
[20]	Freeze output	
[21]	Speed up	
[22]	Speed down	
[23]	Set-up select bit 0	
[24]	Set-up select bit 1	
[34]	Ramp bit 0	
[36]	Mains failure inverse	
[51]	Hand/Auto Start	
[52]	Run permissive	
[53]	Hand start	
[54]	Auto start	
[55]	DigiPot increase	
[56]	DigiPot decrease	
[57]	DigiPot clear	
[62]	Reset Counter A	
[65]	Reset Counter B	
[66]	Sleep Mode	
[78]	Reset Preventive Maintenance Word	
[80]	PTC Card 1	
[85]	Latched Pump Derag	
[120]	Lead Pump Start	
[121]	Lead Pump Alternation	
[130]	Pump 1 Interlock	
[131]	Pump 2 Interlock	
[132]	Pump 3 Interlock	

27-65 Terminal X66/11 Digital Input		
Option:	Function:	
[133]	Pump 4 Interlock	
[134]	Pump 5 Interlock	
[135]	Pump 6 Interlock	
[136]	Pump 7 Interlock	
[137]	Pump 8 Interlock	
[138]	Pump 9 Interlock	

27-66 Terminal X66/13 Digital Input		
Option:	Function:	
[0]	No operation	
[1]	Reset	
[2]	Coast inverse	
[3]	Coast and reset inv	
[5]	DC-brake inverse	
[6]	Stop inverse	
[7]	External interlock	
[8]	Start	
[9]	Latched start	
[10]	Reversing	
[11]	Start reversing	
[14]	Jog	
[15]	Preset reference on	
[16]	Preset ref bit 0	
[17]	Preset ref bit 1	
[18]	Preset ref bit 2	
[19]	Freeze reference	
[20]	Freeze output	
[21]	Speed up	
[22]	Speed down	
[23]	Set-up select bit 0	
[24]	Set-up select bit 1	
[34]	Ramp bit 0	
[36]	Mains failure inverse	
[51]	Hand/Auto Start	
[52]	Run permissive	
[53]	Hand start	
[54]	Auto start	
[55]	DigiPot increase	
[56]	DigiPot decrease	
[57]	DigiPot clear	
[62]	Reset Counter A	
[65]	Reset Counter B	
[66]	Sleep Mode	
[78]	Reset Preventive Maintenance Word	
[80]	PTC Card 1	
[85]	Latched Pump Derag	
[120]	Lead Pump Start	
[121]	Lead Pump Alternation	
[130]	Pump 1 Interlock	
[131]	Pump 2 Interlock	
[132]	Pump 3 Interlock	
[133]	Pump 4 Interlock	

27-66 Terminal X66/13 Digital Input		
Option:	Function:	
[134]	Pump 5 Interlock	
[135]	Pump 6 Interlock	
[136]	Pump 7 Interlock	
[137]	Pump 8 Interlock	
[138]	Pump 9 Interlock	

5.1.10 Connections, 27-7*

Parameters for configuring relay connections.

27-70 Relay		
<p>27-70 Relay is an array parameter used to setup the function of the option relays. Depending on which option is installed only the available relays will be visible. If Extended Cascade Controller is installed, relay 10-12 will be visible. If Advanced Cascade Controller is installed relay 13-20 will be visible. In both cases, the standard relays (Relay1 and Relay2) will be accessible as well as the relays in the B-option MCB 105 (if that option is installed in combination with advanced cascade).</p> <p>To setup the function of each relay, choose the specific relays and then choose the function. If the function option: Standard Relay is chosen, the relay can be used as general purpose relay and the wanted function can then be setup in parameter group 5-4* Relays.</p>		
Option:	Function:	
[0]	Standard Relay	Enable follower drive X
[1]	Drive 2 Enable	
[2]	Drive 3 Enable	
[3]	Drive 4 Enable	
[4]	Drive 5 Enable	
[5]	Drive 6 Enable	
[6]	Drive 7 Enable	
[7]	Drive 8 Enable	
[8]	Pump 1 to Drive 1	
[9]	Pump 1 to Drive 2	
[10]	Pump 1 to Drive 3	
[11]	Pump 1 to Drive 4	
[12]	Pump 1 to Drive 5	
[13]	Pump 1 to Drive 6	
[14]	Pump 1 to Drive 7	
[15]	Pump 1 to Drive 8	
[16]	Pump 2 to Drive 1	
[17]	Pump 2 to Drive 2	
[18]	Pump 2 to Drive 3	
[19]	Pump 2 to Drive 4	
[20]	Pump 2 to Drive 5	
[21]	Pump 2 to Drive 6	
[22]	Pump 2 to Drive 7	
[23]	Pump 2 to Drive 8	
[24]	Pump 3 to Drive 1	
[25]	Pump 3 to Drive 2	

27-70 Relay		
<p>27-70 Relay is an array parameter used to setup the function of the option relays. Depending on which option is installed only the available relays will be visible. If Extended Cascade Controller is installed, relay 10-12 will be visible. If Advanced Cascade Controller is installed relay 13-20 will be visible. In both cases, the standard relays (Relay1 and Relay2) will be accessible as well as the relays in the B-option MCB 105 (if that option is installed in combination with advanced cascade).</p> <p>To setup the function of each relay, choose the specific relays and then choose the function. If the function option: Standard Relay is chosen, the relay can be used as general purpose relay and the wanted function can then be setup in parameter group 5-4* Relays.</p>		
Option:	Function:	
[26]	Pump 3 to Drive 3	
[27]	Pump 3 to Drive 4	
[28]	Pump 3 to Drive 5	
[29]	Pump 3 to Drive 6	
[30]	Pump 3 to Drive 7	
[31]	Pump 3 to Drive 8	
[32]	Pump 4 to Drive 1	
[33]	Pump 4 to Drive 2	
[34]	Pump 4 to Drive 3	
[35]	Pump 4 to Drive 4	
[36]	Pump 4 to Drive 5	
[37]	Pump 4 to Drive 6	
[38]	Pump 4 to Drive 7	
[39]	Pump 4 to Drive 8	
[40]	Pump 5 to Drive 1	
[41]	Pump 5 to Drive 2	
[42]	Pump 5 to Drive 3	
[43]	Pump 5 to Drive 4	
[44]	Pump 5 to Drive 5	
[45]	Pump 5 to Drive 6	
[46]	Pump 5 to Drive 7	
[47]	Pump 5 to Drive 8	
[48]	Pump 6 to Drive 1	
[49]	Pump 6 to Drive 2	
[50]	Pump 6 to Drive 3	
[51]	Pump 6 to Drive 4	
[52]	Pump 6 to Drive 5	
[53]	Pump 6 to Drive 6	
[54]	Pump 6 to Drive 7	
[55]	Pump 6 to Drive 8	
[56]	Pump 7 to Drive 1	
[57]	Pump 7 to Drive 2	
[58]	Pump 7 to Drive 3	
[59]	Pump 7 to Drive 4	
[60]	Pump 7 to Drive 5	
[61]	Pump 7 to Drive 6	
[62]	Pump 7 to Drive 7	
[63]	Pump 7 to Drive 8	
[64]	Pump 8 to Drive 1	

27-70 Relay		
<p>27-70 Relay is an array parameter used to setup the function of the option relays. Depending on which option is installed only the available relays will be visible. If Extended Cascade Controller is installed, relay 10-12 will be visible. If Advanced Cascade Controller is installed relay 13-20 will be visible. In both cases, the standard relays (Relay1 and Relay2) will be accessible as well as the relays in the B-option MCB 105 (if that option is installed in combination with advanced cascade).</p> <p>To setup the function of each relay, choose the specific relays and then choose the function. If the function option: Standard Relay is chosen, the relay can be used as general purpose relay and the wanted function can then be setup in parameter group 5-4* Relays.</p>		
Option:	Function:	
[65]	Pump 8 to Drive 2	
[66]	Pump 8 to Drive 3	
[67]	Pump 8 to Drive 4	
[68]	Pump 8 to Drive 5	
[69]	Pump 8 to Drive 6	
[70]	Pump 8 to Drive 7	
[71]	Pump 8 to Drive 8	
[72]	Pump 1 to Mains	
[73]	Pump 2 to Mains	
[74]	Pump 3 to Mains	
[75]	Pump 4 to Mains	
[76]	Pump 5 to Mains	
[77]	Pump 6 to Mains	
[78]	Pump 7 to Mains	
[79]	Pump 8 to Mains	

27-93 Cascade Option Status		
Option:	Function:	
[0]	Disabled	The cascade option is not used.
[1]	Off	
[2]	Running	
[3]	Running at FSBW	
[4]	Jogging	
[5]	In Open Loop	
[6]	Freezed	
[7]	Coast	
[8]	Alarm	
[9]	Staging	
[10]	Destaging	
[11]	Alternating	
[12]	All Offline	
[13]	Cascade CTL Sleep	

27-94 Cascade System Status		
<p>Cascade System Status is a readout parameter that shows the status of each individual pump.</p>		
Range:	Function:	
0 *	[0 - 25]	

27-95 Advanced Cascade Relay Output [bin]		
Range:	Function:	
0 *	[0 - 255]	Advanced Cascade Relay Output [bin] is a readout parameter that shows the status of each individual relay. From the left to right, the bits correspond the relays 13, 14, 15, 16, 17, 18, 19, 20 respectively.

5.1.11 Readouts, 27-9*

Cascade Control Option Readout Parameters

27-91 Cascade Reference		
<p>Cascade Reference is a readout parameter that shows the reference output for use with follower drives. This reference is available even when the master drive is stopped. This is the speed that the frequency converter is operating at or would be operating at if it were on. It is scaled as a percent of <i>Motor Speed High Limit (4-13 Motor Speed High Limit [RPM] or 4-14 Motor Speed High Limit [Hz])</i>.</p> <p>Units: %</p>		
Range:	Function:	
0 %*	[-200 - 200 %]	

27-92 % Of Total Capacity		
<p>Current % of Total Capacity is a readout parameter that shows the system operating point as a % capacity of total system capacity. 100% means all pumps are on at full speed.</p> <p>Units: %</p>		
Range:	Function:	
0 %*	[0 - 0 %]	

5.2 Parameter Lists

NOTICE

Be aware that parameter group 25-** *Cascade Controller* is only to be used for the Basic Cascade Controller or if one of the options is used for extending the number of pumps of the Basic Cascade Controller. In all other cases use parameter group 27-** *Cascade CTL Option*.

5.2.1 25-** Cascade Controller

Par. No. #	Parameter description	Default value	4-set-up	Change during operation	Conversion index	Type
25-0* System Settings						
25-00	Cascade Controller	ExpressionLimit	2 set-ups	FALSE	-	Uint8
25-02	Motor Start	[0] Direct on Line	2 set-ups	FALSE	-	Uint8
25-04	Pump Cycling	ExpressionLimit	All set-ups	TRUE	-	Uint8
25-05	Fixed Lead Pump	ExpressionLimit	2 set-ups	FALSE	-	Uint8
25-06	Number of Pumps	2 N/A	2 set-ups	FALSE	0	Uint8
25-2* Bandwidth Settings						
25-20	Staging Bandwidth	ExpressionLimit	All set-ups	TRUE	0	Uint8
25-21	Override Bandwidth	100 %	All set-ups	TRUE	0	Uint8
25-22	Fixed Speed Bandwidth	casco_staging_bandwidth (P2520)	All set-ups	TRUE	0	Uint8
25-23	SBW Staging Delay	15 s	All set-ups	TRUE	0	Uint16
25-24	SBW Destaging Delay	15 s	All set-ups	TRUE	0	Uint16
25-25	OBW Time	10 s	All set-ups	TRUE	0	Uint16
25-26	Destage At No-Flow	[0] Disabled	All set-ups	TRUE	-	Uint8

Par. No. #	Parameter description	Default value	4-set-up	Change during operation	Conversion index	Type
25-27	Stage Function	ExpressionLimit	All set-ups	TRUE	-	Uint8
25-28	Stage Function Time	15 s	All set-ups	TRUE	0	Uint16
25-29	Destage Function	ExpressionLimit	All set-ups	TRUE	-	Uint8
25-30	Destage Function Time	15 s	All set-ups	TRUE	0	Uint16
25-4* Staging Settings						
25-40	Ramp Down Delay	10 s	All set-ups	TRUE	-1	Uint16
25-41	Ramp Up Delay	2 s	All set-ups	TRUE	-1	Uint16
25-42	Staging Threshold	ExpressionLimit	All set-ups	TRUE	0	Uint8
25-43	Destaging Threshold	ExpressionLimit	All set-ups	TRUE	0	Uint8
25-44	Staging Speed [RPM]	0 RPM	All set-ups	TRUE	67	Uint16
25-45	Staging Speed [Hz]	0 Hz	All set-ups	TRUE	-1	Uint16
25-46	Destaging Speed [RPM]	0 RPM	All set-ups	TRUE	67	Uint16
25-47	Destaging Speed [Hz]	0 Hz	All set-ups	TRUE	-1	Uint16
25-5* Alternation Settings						
25-50	Lead Pump Alternation	ExpressionLimit	All set-ups	TRUE	-	Uint8
25-51	Alternation Event	[0] External	All set-ups	TRUE	-	Uint8
25-52	Alternation Time Interval	24 h	All set-ups	TRUE	74	Uint16
25-53	Alternation Timer Value	0 N/A	All set-ups	TRUE	0	VisSt[7]

Par. No. #	Parameter description	Default value	4-set-up	Change during operation	Conversion index	Type
25-54	Alternation Predefined Time	ExpressionLimit	All set-ups	TRUE	0	Time Of Day Wo Date
25-55	Alternate if Load < 50%	[1] Enabled	All set-ups	TRUE	-	Uint8
25-56	Staging Mode at Alternation	[0] Slow	All set-ups	TRUE	-	Uint8
25-58	Run Next Pump Delay	0.1 s	All set-ups	TRUE	-1	Uint16
25-59	Run on Mains Delay	0.5 s	All set-ups	TRUE	-1	Uint16
25-8* Status						
25-80	Cascade Status	0 N/A	All set-ups	TRUE	0	VisStor[25]
25-81	Pump Status	0 N/A	All set-ups	TRUE	0	VisStor[25]

Table 5.1

5.2.2 27-** Cascade CTL Option

Par. No. #	Parameter description	Default value	4-set-up	Change during operation	Conversion index	Type
27-0* Control & Status						
27-01	Pump Status	[0] Ready	All set-ups	TRUE	-	Uint8
27-02	Manual Pump Control	[0] No Operation	2 set-ups	TRUE	-	Uint8
27-03	Current Runtime Hours	0 h	All set-ups	TRUE	74	Uint32
27-04	Pump Total Lifetime Hours	0 h	All set-ups	TRUE	74	Uint32
27-1* Configuration						
27-10	Cascade Controller	null	2 set-ups	FALSE	-	Uint8

Par. No. #	Parameter description	Default value	4-set-up	Change during operation	Conversion index	Type
25-82	Lead Pump	0 N/A	All set-ups	TRUE	0	Uint8
25-83	Relay Status	0 N/A	All set-ups	TRUE	0	VisStor[4]
25-84	Pump ON Time	0 h	All set-ups	TRUE	74	Uint32
25-85	Relay ON Time	0 h	All set-ups	TRUE	74	Uint32
25-86	Reset Relay Counters	[0] Do not reset	All set-ups	TRUE	-	Uint8
25-9* Service						
25-90	Pump Interlock	[0] Off	All set-ups	TRUE	-	Uint8
25-91	Manual Alternation	0 N/A	All set-ups	TRUE	0	Uint8

Par. No. #	Parameter description	Default value	4-set-up	Change during operation	Conversion index	Type
27-11	Number Of Drives	ExpressionLimit	2 set-ups	FALSE	0	Uint8
27-12	Number Of Pumps	ExpressionLimit	2 set-ups	FALSE	0	Uint8
27-14	Pump Capacity	100 %	2 set-ups	FALSE	0	Uint16
27-16	Runtime Balancing	[0] Balanced Priority 1	2 set-ups	TRUE	-	Uint8
27-17	Motor Starters	[0] Direct Online	2 set-ups	FALSE	-	Uint8
27-18	Spin Time for Unused Pumps	ExpressionLimit	All set-ups	TRUE	0	Uint16
27-19	Reset Current Runtime Hours	[0] Do not reset	All set-ups	TRUE	-	Uint8
27-2* Bandwidth Settings						

Par. No. #	Parameter description	Default value	4-set-up	Change during operation	Conversion index	Type
27-20	Normal Operating Range	ExpressionLimit	All set-ups	TRUE	0	Uint8
27-21	Override Limit	100 %	All set-ups	TRUE	0	Uint8
27-22	Fixed Speed Only Operating Range	ExpressionLimit	All set-ups	TRUE	0	Uint8
27-23	Staging Delay	15 s	All set-ups	TRUE	0	Uint16
27-24	Destaging Delay	15 s	All set-ups	TRUE	0	Uint16
27-25	Override Hold Time	10 s	All set-ups	TRUE	0	Uint16
27-27	Min Speed Destage Delay	ExpressionLimit	All set-ups	TRUE	0	Uint16
27-3* Staging Speed						
27-30	Auto Tune Staging Speeds	[1] Enabled	All set-ups	TRUE	-	Uint8
27-31	Stage On Speed [RPM]	ExpressionLimit	All set-ups	TRUE	67	Uint16
27-32	Stage On Speed [Hz]	ExpressionLimit	All set-ups	TRUE	-1	Uint16
27-33	Stage Off Speed [RPM]	ExpressionLimit	All set-ups	TRUE	67	Uint16
27-34	Stage Off Speed [Hz]	ExpressionLimit	All set-ups	TRUE	-1	Uint16
27-4* Staging Settings						
27-40	Auto Tune Staging Settings	[0] Disabled	All set-ups	TRUE	-	Uint8
27-41	Ramp Down Delay	10.0 s	All set-ups	TRUE	-1	Uint16
27-42	Ramp Up Delay	2.0 s	All set-ups	TRUE	-1	Uint16

Par. No. #	Parameter description	Default value	4-set-up	Change during operation	Conversion index	Type
27-43	Staging Threshold	ExpressionLimit	All set-ups	TRUE	0	Uint8
27-44	Destaging Threshold	ExpressionLimit	All set-ups	TRUE	0	Uint8
27-45	Staging Speed [RPM]	0 RPM	All set-ups	TRUE	67	Uint16
27-46	Staging Speed [Hz]	0.0 Hz	All set-ups	TRUE	-1	Uint16
27-47	Destaging Speed [RPM]	0 RPM	All set-ups	TRUE	67	Uint16
27-48	Destaging Speed [Hz]	0.0 Hz	All set-ups	TRUE	-1	Uint16
27-5* Alternate Settings						
27-50	Automatic Alternation	[0] Disabled	All set-ups	FALSE	-	Uint8
27-51	Alternation Event	null	All set-ups	TRUE	-	Uint8
27-52	Alternation Time Interval	0 min	All set-ups	TRUE	70	Uint16
27-53	Alternation Timer Value	0 min	All set-ups	TRUE	70	Uint16
27-54	Alternation At Time of Day	[0] Disabled	All set-ups	TRUE	-	TimeOfDayOfWeek
27-55	Alternation Predefined Time	ExpressionLimit	All set-ups	TRUE	0	TimeOfDayOfWeek
27-56	Alternate Capacity is <	0 %	All set-ups	TRUE	0	Uint8
27-58	Run Next Pump Delay	0.1 s	All set-ups	TRUE	-1	Uint16
27-6* Digital Inputs						
27-60	Terminal X66/1 Digital Input	[0] No operation	All set-ups	TRUE	-	Uint8

Par. No. #	Parameter description	Default value	4-set-up	Change during operation	Conversion index	Type
27-61	Terminal X66/3 Digital Input	[0] No operation	All set-ups	TRUE	-	Uint8
27-62	Terminal X66/5 Digital Input	[0] No operation	All set-ups	TRUE	-	Uint8
27-63	Terminal X66/7 Digital Input	[0] No operation	All set-ups	TRUE	-	Uint8
27-64	Terminal X66/9 Digital Input	[0] No operation	All set-ups	TRUE	-	Uint8
27-65	Terminal X66/11 Digital Input	[0] No operation	All set-ups	TRUE	-	Uint8
27-66	Terminal X66/13 Digital Input	[0] No operation	All set-ups	TRUE	-	Uint8
27-7* Connections						

Table 5.2

Par. No. #	Parameter description	Default value	4-set-up	Change during operation	Conversion index	Type
27-70	Relay	[0] Standard Relay	2 set-ups	FALSE	-	Uint8
27-9* Readouts						
27-91	Cascade Reference	0.0 %	All set-ups	TRUE	-1	Int16
27-92	% Of Total Capacity	0 %	All set-ups	TRUE	0	Uint16
27-93	Cascade Option Status	[0] Disabled	All set-ups	TRUE	-	Uint8
27-94	Cascade System Status	0 N/A	All set-ups	TRUE	0	VisStr[25]
27-95	Advanced Cascade Relay Output [bin]	0 N/A	All set-ups	TRUE	0	Uint16

6 Configuration Examples

6.1 Master/Follower

The following example describes configuration of 3 variable speed pumps, see *Illustration 2.4*. It is assumed that the pressure transmitter used as feedback sensor and has a range from 0-10 bar. An internal reference is used.

For more detailed information on the master-follower application and on the staging/de-staging principle, see *2 Application Types* and *4 Configuring the System*.

The necessary steps for the configuration are:

- Basic Settings for the master and for the follower (Motor data, Display etc.)
- Configuration of the master
- Configuration of one of the followers
- Copying the settings with the LCP from this follower to the other followers

6.1.1 Basic Settings

Basic settings (master and follower)	Example/remarks
0-02 Motor Speed Unit	[1] Hz
1-20 Motor Power [kW]	
1-22 Motor Voltage [V]	
1-23 Motor Frequency [Hz]	50
1-24 Motor Current [A]	
1-25 Motor Nominal Speed [RPM]	
1-29 Automatic Motor Adaptation (AMA)	
3-41 Ramp 1 Ramp up Time [s]	Settings must be the same for master and followers
3-42 Ramp 1 Ramp down Time [s]	
4-11 Motor Speed Low Limit [RPM]	
4-12 Motor Speed Low Limit [Hz]	
4-13 Motor Speed High Limit [RPM]	
4-14 Motor Speed Low Limit [Hz]	

Table 6.1 Basic Settings

NOTICE

Ensure that the motor is properly running before setting the master drive to closed loop operation.

Display settings - master drive	Example
0-20 Display Line 1.1 Small	[1601] Reference
0-21 Display Line 1.2 Small	[1652] Feedback
0-22 Display Line 1.3 Small	[1614] Motor current
0-23 Display Line 2 Large	[1613] Frequency
0-24 Display Line 3 Large	[2794] Cascade System Status
Display settings - follower drives	Example
0-20 Display Line 1.1 Small	[1650] External Reference
0-24 Display Line 3 Large	[1613] Frequency

Table 6.2

6.1.2 Master Drive Settings

27-1* Configuration	Example
27-10 Cascade Controller	[1] Master/Follower
27-11 Number Of Drives	3
27-16 Runtime Balancing	[0] Array, Balanced Priority 1
27-18 Spin Time for Unused Pumps	0 (s) , Off
27-19 Reset Current Runtime Hours	[1] Do reset

Table 6.3 Master Drive Settings, 27-1* Configuration

27-2* Bandwidth Settings	Example
27-21 Override Limit	100 (%)
27-23 Staging Delay	15 (s)
27-24 Destaging Delay	15 (s)

Table 6.4 Master Drive Settings, 27-2* Bandwidth Settings

27-3* Staging Speeds	Example/Remarks
27-30 Auto Tune Staging Speeds	Enabled [1]
27-31 Stage On Speed [RPM]	Arrays for the staging speeds, see example in <i>Table 6.10</i>
27-32 Stage On Speed [Hz]	
27-33 Stage Off Speed [RPM]	
27-34 Stage Off Speed [Hz]	

Table 6.5 Master Drive Settings, 27-3* Staging Speeds

27-5* Alternate Settings	Example
27-52 Alternation Time Interval	0 (min), Disabled
27-54 Alternation At Time of Day	[0] Disabled
27-56 Alternate Capacity is <	0 (s), Off

Table 6.6 Master Drive Settings, 27-5* Alternate Settings

An array parameter is used to configure the output of the master drive for the start signal of the follower drives.

27-7* Connections	Example
27-70.0 Relay 1	[1] Drive 2 Enable
27-70.1 Relay 2	[2] Drive 3 Enable

Table 6.7 Master Drive Settings, 27-7* Connections

6.1.3 Follower Drive Settings

Follower drives must be configured for open loop operation with basic settings as described in 6.1.1 *Basic Settings*.

Configure only one of the followers and to copy the settings by using the LCP.

Open Loop Settings (Follower)	Example/Remarks
1-00 Configuration Mode	[0] Open Loop
3-02 Minimum Reference	0
3-03 Maximum Reference	50 (Hz)
3-15 Reference 1 Source	[7] Pulse Input 29

Table 6.8 Open Loop Settings (Follower)

The terminal 29 is used as a pulse input for the reference signal and must be scaled.

5-** Digital In/Out (Follower)	Example/Remarks
5-02 Terminal 29 Mode	[0] Input
5-13 Terminal 29 Digital Input	[32] Pulse Input
5-50 Terminal 29 Low Frequency	0 (Hz)
5-51 Terminal 29 High Frequency	5000 (Hz)
5-52 Term. 29 Low Ref. Value	0
5-53 Term. 29 High Ref. Value	50 (Hz)
5-10 Terminal 18 Digital Input	Start

Table 6.9 5-** Digital In/Out (Follower)

6.1.4 Sleep Mode

The following describes how to configure the frequency converter for de-staging the last variable speed pump in applications with more than one frequency converter.

The necessary steps for the configuration are:

1. Set parameter 27-34.01 higher than the minimum speed in 4-11 *Motor Speed Low Limit [RPM]*/ 4-12 *Motor Speed Low Limit [Hz]* to enable sleep function (setting it to zero will disable the function).
2. Set 27-21 *Override Limit* to wake up the application.

After wake up the pump with the least running hours starts.

NOTICE

If the master drive does not wake up properly, the frequency converter is not able to reach its de-staging speed and the delays in parameter group 27-** have to be adjusted.

	Stage ON [Hz]	Stage OFF [Hz]
Stage 1	48.5 (i.e. parameter 2732.1)	30 (i.e. parameter 2734.1)
Stage 2	48.5 (i.e. parameter 2732.2)	40 (i.e. parameter 2734.2)
Stage 3	- (i.e. parameter 2732.3)	42 (i.e. parameter 2734.3)

Table 6.10 Example Settings for 27-3*, 3 Pumps with Sleep Mode Enabled

- “Stage X” refers to the stage the cascade is running in (stage 1 ⇒ cascade is running in stage 1, only 1 pump is running)
- Pumps 2 and 3 are started on 48.5 Hz
- Pump 3 is stopped on 42 Hz, Pump 2 is stopped on 40 Hz and Pump 1 is stopped on 30 Hz
- It might be necessary to fine adjust the stage on/off speeds to optimise the energy consumption, if not auto tuned. It is recommended to use Auto Tune Staging Speeds by enabling the feature in 27-30 *Auto Tune Staging Speeds*.

NOTICE

Parameter 2732.3 is irrelevant in this case, because there is nothing left to stage on in stage 3.

Index

A
 AC Mains..... iii
 Approvals..... iii

B
 Bandwidth Settings, 27-2*..... 26
 Basic Cascade Controller..... 3

C
 Cascade
 Control..... 3
 Controller..... 37
 Controller Option..... 3, 4
 CTL Option..... 38
 CTL Option, 27-** 24
 Closed Loop Control..... 17
 Configuration Of Multiple Frequency Converters..... 16
 Configuration, 27-1* 26
 Configuring The System..... 16
 Control
 & Status, 27-0* 25
 System..... 4
 Critical Systems..... 20

D
 De-staging
 De-staging..... 17, 21
 Delay, 27-24..... 28
 Discharge Time..... iii
 Drive Configurations..... 5

E
 Extension Of Basic Cascade..... 5

F
 Feedback
 Pressure..... 8, 20
 Sensor..... 17
 Fixed
 Speed..... 20
 Speed Pump Configuration..... 6
 Speed Pumps..... 4
 Follower Drive..... 4

I
 Input Power..... iii

L
 Lead Pump..... 19, 20, 19

Lifetime Hours..... 19

M
 Manual Pump Control..... 18
 Master Drive..... 4
 Master-Follower Configuration..... 7
 Min-Speed De-stage Delay, 27-27..... 28
 Mixed
 Pump Configuration..... 9, 8
 Pump Selection..... 16
 Multiple Drives..... 19

N
 Number
 Of Frequency Converters..... 16
 Of Pumps, 27-12..... 26

O
 Open Loop Mode..... 4
 Optional Equipment..... 4
 Override
 Limit..... 20, 27
 Staging/De-staging..... 20

P
 PID Controller..... 17
 Pressure Fluctuations..... 7
 Pump
 Capacity..... 16
 Spin..... 19

R
 Runtime Balancing..... 16, 19

S
 Setting-up The Cascade Parameters..... 16
 Single Frequency Converter..... 19
 Soft Starters..... 10
 Software Version..... 3
 Spin
 Time..... 19, 26
 Time For Unused Pumps..... 16
 Staging
 Staging..... 17, 20
 And De-staging Decisions..... 8
 Settings, 27-4* 29
 Speed, 27-3* 28
 Staging/de-staging..... 20
 Staging/De-staging
 Of Fixed Speed Pumps..... 17
 Of Variable Speed Pumps..... 17

Supported Configurations..... 5

Symbols..... iii

U

Unequal Size Pump Configuration..... 8

V

Variable Speed Pumps..... 4



www.danfoss.com/drives

Danfoss can accept no responsibility for possible errors in catalogues, brochures and other printed material. Danfoss reserves the right to alter its products without notice. This also applies to products already on order provided that such alterations can be made without subsequential changes being necessary in specifications already agreed. All trademarks in this material are property of the respective companies. Danfoss and the Danfoss logotype are trademarks of Danfoss A/S. All rights reserved.

