

Heat Exchangers

Plate and Frame

FFW AHRI

Shell and Tube

W & S

Brazed

FFB



www.flofab.com

001-cat-2016-he

TABLE OF CONTENTS

PLATE AND FRAME - PRODUCT SPECIFICATIONS.....	2
PLATE AND FRAME - TYPICAL SPECIFICATIONS.....	3
PLATE AND FRAME - GRID, CONNECTION TYPES, DESIGN LIMITS.....	4
PLATE AND FRAME - SAVINGS EXPLANATIONS.....	5
SHELL AND TUBES - PRODUCT SPECIFICATIONS.....	6
SHELL AND TUBES - TYPICAL SPECIFICATIONS/ NOMENCLATURE.....	7
SHELL AND TUBES - GRID FOR "S" MODELS.....	8-12
SHELL AND TUBES - GRID FOR "SE" MODELS.....	13-17
SHELL AND TUBES - GRID FOR "W" MODELS.....	18-22
SHELL AND TUBES - GRID FOR "WF" MODELS.....	23-27
NEW GENERATION :	
SHELL AND TUBES - GRID FOR "S" MODELS.....	28-30
SHELL AND TUBES - GRID FOR "W" MODELS.....	31-33
SHELL AND TUBES - TYPICAL "S" CONNECTIONS SIZE AND TYPES.....	34
SHELL AND TUBES - TRANSFER SOLUTION.....	35
SHELL AND TUBES - SAVINGS EXPLANATIONS.....	36
BRAZED - BL SERIES - PRODUCT SPECIFICATIONS.....	37-50

HISTORY

Flo Fab was established in 1981 by Denis Gauvreau who created and developed the products line and constantly being perfected by Marc Gauvreau, as well as by a team of professional engineers and designers. It's a combination of existing designs from several renowned products and the innovative ideas of a new generation professionals.

Through the years, Flo Fab has acquired several companies and service entities including : AQUA-PROFAB (ASME Tanks manufacturer), MÉNARD, LÉONARD ÉLECTRIQUE, PMA. , Furthermore Flo Fab purchased equipment, fabrication designs and patterns from IDEALCO, a manufacturer of shell and tube type heat exchangers.

The after sales services, sales, engineering, R&D, production, quality control, accounting and administration departments of all the above companies share the same location.

In December 2014, Marc Gauvreau, son of the founder, acquired all shares of The company. Flo Fab and is constantly investing in new state of the art innovations new product like the XRI series and Prefab Skid for Hydronic Heating 8 cooling system, pumping systems. This has allowed Flo Fab to retain competent and experienced staff of professionals with varied and specialized abilities that constantly work on improving our existing products and add new engineered solutions that exceeding customer's expectations . Flo Fab has grown quite rapidly and now proudly offers of a wide range of products available directly from one manufacturer. This includes pumps & pump packages, tanks, heat exchangers & hydronic accessories. This allows each project stakeholders to enjoy economical savings, peace of mind, best value for their investment and optimized total cost of ownership.





● Product Specifications FFW Series

PLATE HEAT EXCHANGERS WITH GASKETS

Water is the most effective media for heat transfer. In typical HVAC installations, primary loops circulate water throughout a building to transport energy from the source to the building load. A chiller or central cooling source is used to remove heat and a boiler or central heating source is used to add heat to these primary loops. Heat exchangers transfer heat from the building's primary loops to secondary loops and can also serve as a separation device to reduce system costs. These loops can serve auxiliary equipment like heating or cooling secondary systems, potable water heating, and pool water heating systems. Secondary loops provide better temperature control, differentiated system operating pressures. Separation of water and glycol loops. separation of primary water and potable water loops. and separation of potentially contaminated open systems to closed loops. In all cases, the heat exchanger is relied on to transfer as much heat as possible at the lowest cost.

HOW IT WORKS ?

The Flo Fab heat exchanger consists of stamped plates designed to maximize heat transfer. Gaskets are fixed between the plates to contain the two separate fluids. These fluids flow alternately between every other plate, counter-flowing to produce the greatest rate of heat transfer and provide the closest temperature approach to the incoming cold fluid. The stamped plates use enhanced surface area flow to create scrubbing turbulence that increase the U-coefficient and increases heat transfer.

The heat transfer plates are typically stainless steel or titanium and vary in thickness from 0.4mm to 0.6mm. This allows for tailored designs of all pressures and corrosion allowances for any job. Glueless gaskets are made from specialty elastomers and applied to the plates with an integrated clip for a clean, reliable installation. The plates and gaskets are then constrained by a heavy-duty base frame that is ASME—certified to stringent pressure vessel standards.

Heat transfer plates are available in many lengths, widths, connection sizes, thicknesses and stamped configurations that create various depths and angles to maximize heat transfer and reduce installed cost. The most common plate angles are 30° and 60°. The 30° plate creates a tortuous path for greater heat transfer, but with a higher pressure drop than the 60° plate. Flo Fab' sizing software will calculate the optimum heat transfer plate and plate sequencing for any application.

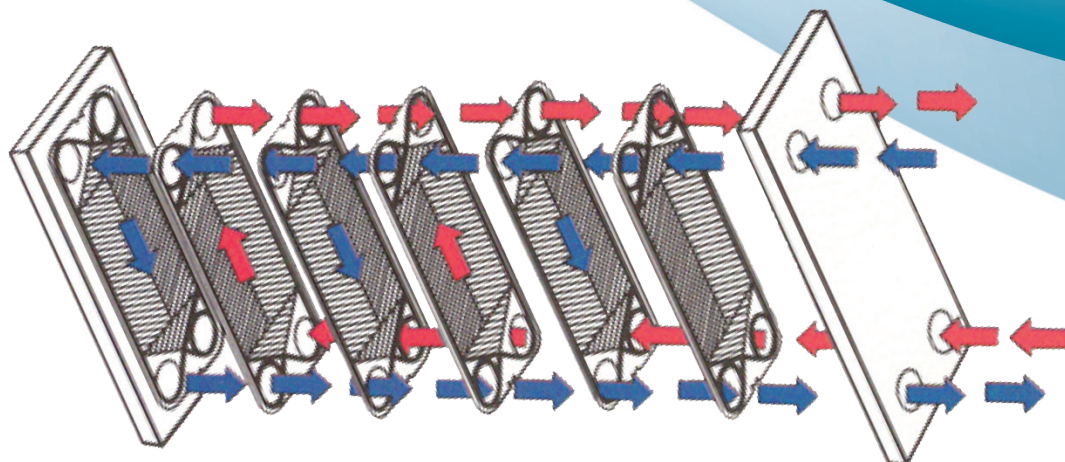



- FFW Series

MATERIAL OF CONSTRUCTION

PLATES:

Stainless Steel (304SS or 316SS)
or Titanium

GASKETS:

Nitrile, EPDM

CERTIFICATION

SAFETY:

ASME for pressure vessels
CRN for Canadian Registration
AHRI upon Request



TYPICAL SPECIFICATIONS

Furnish and install, as shown on plans, a Flo Fab model _____ to heat or cool with the capacity and pressure/temperature rating as detailed in the schedule. The heat exchanger must be constructed with most recent addendum of Section VIII of the ASME Boiler and Pressure Vessel Code.

Each heat exchanger shall be Flo Fab Model _____ or approved equal.

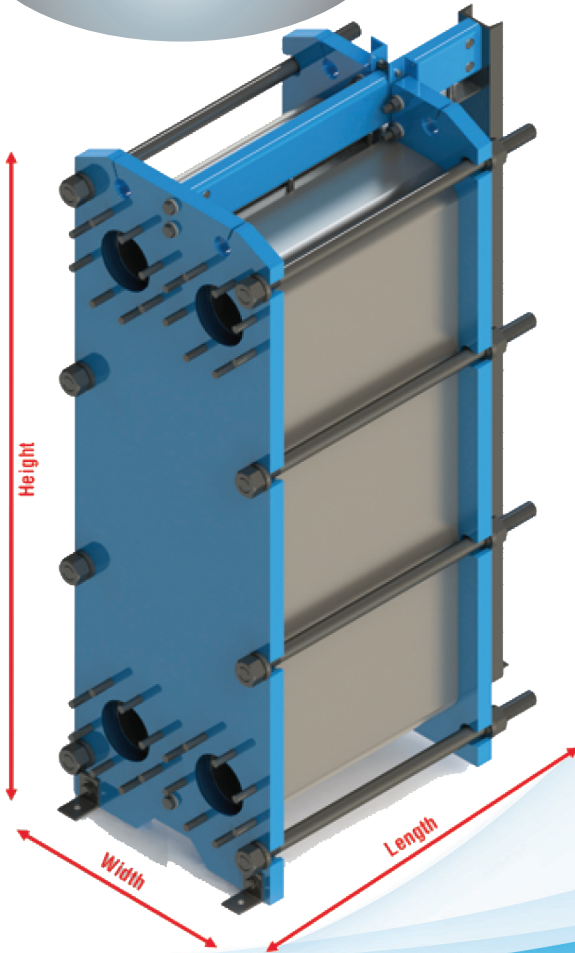

DESIGN LIMITS

MAX FLOW:
10,000 GPM // 2271 m³/hr

DUTY MAX:
50,000,000 BTU/HR

MAX PRESSURE:
150/300/400 PSI // 1034/2068/2758 kPa

MAX TEMPERATURE:
320°F // 160°C

CONNECTION TYPES

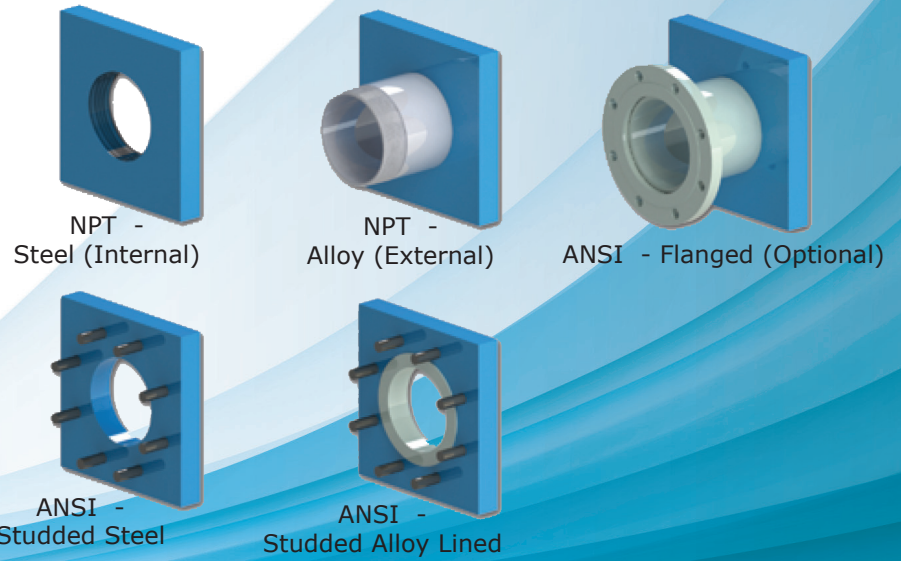

√	Model Number	Dimensions									Weight				
		Max. Flowrate (GPM)	Max. Flowrate (m ³ /h)	Height (in)	Height (mm)	Width (in)	Width (mm)	Max. Length (in)	Max. Length (mm)	Conn. Size	Area Max.	Base (lbs)	Base (kg)	Per Plate (lbs)	Per Plate (kg)
	FFW10	60	13.63	21	533	8	203	18	457	1	30	150	68	0.5	0.23
	FFW20	250	56.77	35	889	14	356	60	1524	2	400	500	227	2.0	0.91
	FFW21	250	56.77	35	889	14	356	60	1524	2	500	500	227	1.5	0.68
	FFW40	1000	227.09	44	1118	19	483	84	2134	4	600	1000	454	3.5	1.59
	FFW41	1000	227.09	44	1118	19	483	84	2134	4	1000	1000	454	3.0	1.36
	FFW45	1000	227.09	74	1880	19	483	96	2438	4	2000	1600	726	6.0	2.72
	FFW60	2200	499.60	75	1905	25	635	108	2743	6	2400	3000	1361	8.0	3.63
	FFW61	2200	499.60	75	1905	25	635	108	2743	6	4200	3000	1361	7.0	3.18
	FFW80	4000	908.37	88	2235	30	762	192	4877	8	4500	3000	1361	11.0	4.99
	FFW81	4000	908.37	88	2235	30	762	192	4877	8	5000	3000	1361	10.0	4.54
	FFW101	5000	1135.46	109	2769	35	889	216	5486	10	11000	5500	2495	16.0	7.26
	FFW140	10000	2270.92	112	2845	45	1143	240	6096	14	12500	8000	3629	20.0	9.07
		Double Wall Models													
	FFW10DW	60	13.63	21	533	8	203	18	457	1	30	150	60	0.5	0.23
	FFW20DW	250	56.77	35	889	14	356	60	1524	2	400	500	250	2.0	0.91
	FFW21DW	250	56.77	35	889	14	356	60	1524	2	500	500	250	2.0	0.91
	FFW41DW	1000	227.09	44	1118	19	483	84	2134	4	1000	1000	1000	3.5	1.59
	FFW45DW	1000	227.09	74	1880	19	483	96	2438	4	2000	1600	1000	6.0	2.72
	FFW61DW	2200	499.60	75	1905	25	635	108	2743	6	4200	3000	2200	7.0	3.18

Other size available upon request.



“With over 35 years of experience in pressure vessel design and manufacture, our goal is to provide sustainable **energy saving solutions** that help make a greener HVAC world.”



Lower Air Conditioning Costs

The Flo Fab heat exchanger can result in 30% annual energy savings for cooling when used as a water side economizer to supplement or replace a mechanical chiller. The greatest savings are realized at installations that have year-round chilled water requirements such as data centers and hospitals.

Lower Pumping Costs

Flo Fab uses only the most efficient heat transfer plate designs to maximize temperature cross and allow the closest approach temperatures that ensure the greatest percentage of heat recovery. The shape of the corrugation in FloFab heat transfer plates maintains high turbulence at lower velocities, which allows lower flows to have high rates of heat transfer. This improved efficiency, coupled with the advantages of variable speed pumping, can result in tremendous energy savings.

The energy used by the pump serving the heat exchanger can be reduced as much as 50% by lowering the pressure drop and/or the flow through the heat exchanger while maintaining the required amount of heat transfer.

Lowest installed Cost

Flo Fab heat exchangers are less expensive, more compact, and easier to install because they utilize only the most efficient heat transfer plate designs. Connections are on the fixed end to reduce first cost installation and increase serviceability. The units are fully assembled and ASME hydrostatically tested. Flo Fab can then be disassembled for delivery through a small opening and reassembled on site.

Low Risk

All units come certified by the appropriate safety code (ASME, CRN, etc.). Every Flo Fab heat exchanger is sized with 20% excess plate capacity so plates can be added to increase the system performance. Heat transfer plates are corrosion resistant materials. The gaskets are vented to the outside so there is no cross contamination between fluids. If a gasket fails, for potable water applications, double wall heat transfer plates are used to prevent cross contamination if there is a breach of a plate. Every unit is provided with a safety shield that surrounds the plates and gaskets.

Less Maintenance

All heat exchangers require preventative maintenance and service. Flo Fab exchangers are designed for easy serviceability. All plate hanging surfaces are stainless steel so plates slide easily. Heat transfer plates have either corner inter-locking tabs or a live point alignment system to make closing and sealing the unit consistent. Glue-free gaskets secure around the outer edge of the heat transfer plate. This design allows for the ability to perform a visual check to confirm the gasket is in the proper location for best sealing and trouble free operation.



● Product Specifications

S & W Series

Steam and water are effective media for transferring heat. In typical HVAC heat applications, steam or hot water primary loops distribute heat from the central boiler out to secondary loops through U-tube style heat exchangers. Heat exchangers transfer heat from the building's primary loops to secondary loops and can also serve as separation devices to reduce system costs. These loops serve auxiliary equipment like heating systems, potable water heating and pool water heating. The heat exchangers provide better temperature control, differential system operating pressures and separation of steam, water, glycol and potable water systems. In all cases, the heat exchanger is relied on to transfer as much heat as possible at the lowest cost.

How it works

The Flo Fab' shell and tube heat exchanger consists of two sides for two different fluids. The Tube Side fluid flows inside the tubes and is diverted by the heat exchanger head located on the end into two or four passes or circuits. The Shell Side fluid flows on the outside of the tubes and is contained by the shell where it is diverted by baffles or tube supports that also carry the weight of the tubes. The wall of the tubes is the heat transfer surface. The tube bundle consists of U-shaped tubes confined at one end by the tube sheet that separates the two fluids. The tube bundle is assembled into a steel shell and head that forms a two sided heat exchanger.

Flo Fab' shell and tube heat exchangers comes in two different configurations depending on the shell side fluid:

S Steam in Shell

W Boiler Water in Shell

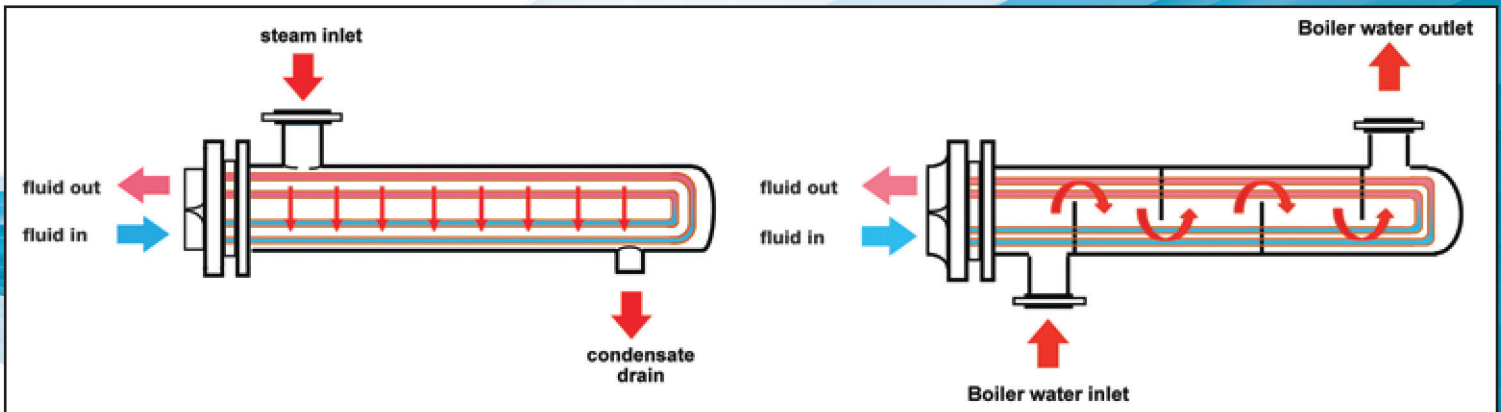

The S works by introducing steam (water vapor) into the shell where it naturally distributes across the outer tube surface and condenses and heats the water inside the tubes. The condensate exits through a drain in the shell. Tube supports carry the weight of the tubes and do not divert the steam.

The W works by introducing boiler water into the shell where it is diverted back and forth across the tube surface by baffles, heating the water inside the tubes. The distance between the baffles is called the «battle spacing,» which controls the rate of heat transfer and pressure drop of the shell side fluid.

Material of Construction

TUBES

Standard: Stainless Steel // Option: Cooper or Cu Ni

SHELL

Standard: Steel // Option: Stainless

TUBESHEETS

Standard: Steel // Option: Stainless, Brass, 90/10 Cu Ni

HEADS

Standard: Cast Iron // Option: Steel, Stainless

Certification

SAFETY

ASME for pressure vessels
CRN for Canadian Registration

Design Limits

TUBE SIDE:

Standard: 125 // Option: 150, 300, 400 PSI
400°F - 204°C

SHELL SIDE:

Standard: 150 // Option: 300 PSI
375°F - 190°C

• **Product Specifications**

SDW & WDW Series

SDW/WDW Double Wall

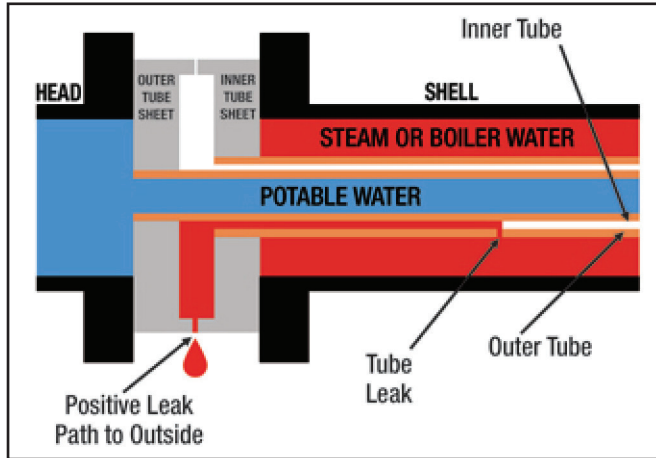

The SDW and WDW are made with inner and outer double tubes and double tube sheets that provide a positive leak path between the two fluids. This design prevents the cross-contamination of the potable water by the surrounding steam or treated boiler water.

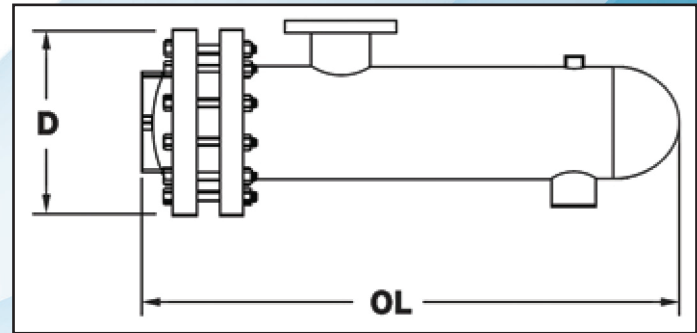

NOMENCLATURE

- S** = Steam to Liquid
- W** = Liquid to Liquid
- E** = Extended Shell
- F** = Head Flanged
- TH** = Tank Heater Single and Double
- DW** = Double Wall

Please note that the models SDW & WDW are available upon request.



Typical **S** Dimensions

PLEASE CONSULT FACTORY FOR DIMENSIONS

√	Size		Steam In	Cond Out
		LBS	NPT	NPT
	S-0402	60	2	1
	S-0403	76	2	1
	S-0404	92	2	1
	S-0405	108	2.5	1.25
	S-0406	124	2.5	1.25
	S-0407	140	2.5	1.25
	S-0408	156	2.5	1.25
	S-0409	172	2.5	1.25
	S-0410	186	2.5	1.25
	S-0411	200	2.5	1.25
	S-0412	214	2.5	1.25
	S-0602	132	1.5	1
	S-0603	159	2	1
	S-0604	186	2.5	1
	S-0605	213	2.5	1
	S-0606	240	3	1
	S-0607	267	3	1
	S-0608	294	3	1
	S-0802	220	2	1
	S-0803	260	2.5	1
	S-0804	300	3	1
	S-0805	340	4*	1
	S-0806	380	4*	1.25
	S-0807	420	4*	1.25
	S-0808	460	6*	1.25

Add 1/4 to dimension B for Double Wall

*indicates ANSI type connections

DESIGN CONDITIONS(S4,S6 & S8)			Notes: Units fabricated and tested in accordance with ASME Section VIII Division 1. Heat exchanger supports provided separately. All dimensions + / - 0.125".
	TUBE SIDE	SHELL SIDE	
DESIGN PRESSURE	150 Psig	150 Psig	
TEST PRESSURE	195 Psig	195 Psig	
DESIGN TEMPERATURE	375 °F	375 °F	
MIN METAL: TEMPERATURE	35 °F	35 °F	



Typical **S** Dimensions

PLEASE CONSULT FACTORY FOR DIMENSIONS

✓	Size	Steam In Cond Out		
		LBS	ANSI	NPT
	S-1002	340	4	1.5
	S-1003	400	4	1.5
	S-1004	460	6	2
	S-1005	520	6	2
	S-1006	580	6	2
	S-1007	640	6	2
	S-1008	700	6	2
	S-1009	760	6	2
	S-1010	820	6	2
	S-1203	565	6	2
	S-1204	670	6	2
	S-1205	775	6	2
	S-1206	880	8	2
	S-1207	985	8	2.5
	S-1208	1090	8	2.5
	S-1209	1195	8	2.5
	S-1210	1300	8	2.5
	S-1211	1405	8	2.5
	S-1212	1510	8	2.5
	S-1403	695	8	2
	S-1404	815	8	2
	S-1405	935	8	2.5
	S-1406	1055	8	2.5
	S-1407	1180	8	2.5
	S-1408	1300	8	2.5
	S-1409	1420	8	2.5
	S-1410	1540	8	2.5
	S-1411	1661	8	2.5
	S-1412	1781	8	2.5

Add 1/4 to dimension B for Double Wall

DESIGN CONDITIONS (S10,S12/S14)			Notes: Units fabricated and tested in accordance with ASME Section VIII Division 1. Heat exchanger supports provided separately. All dimensions + / - 0.125".
	TUBE SIDE	SHELL SIDE	
DESIGN PRESSURE	125/150 Psig	150 Psig	
TEST PRESSURE	163/195 Psig	195 Psig	
DESIGN TEMPERATURE	375 °F	375 °F	
MIN METAL: TEMPERATURE	35 °F	35 °F	



Typical **S** Dimensions

PLEASE CONSULT FACTORY FOR DIMENSIONS

√	Size		Steam In	Cond Out
		LBS	ANSI	NPT
	S-1603		10	3
	S-1604		10	3
	S-1605		10	3
	S-1606		10	3
	S-1607		10	3
	S-1608		10	3
	S-1609		10	3
	S-1610		10	3
	S-1611		10	3
	S-1612		10	3
			ANSI	ANSI
	S-18			
			ANSI	ANSI
	S-2003	1260	12	4
	S-2004	1500	12	4
	S-2005	1740	12	4
	S-2006	1980	12	4
	S-2007	2220	12	4
	S-2008	2460	12	4
	S-2009	2700	12	4
	S-2010	2940	12	4
	S-2011	3180	12	4
	S-2012	3420	12	4

This Section is Intentionally Left Blank For Futur Data

Add 1/4 to dimension B for Double Wall



Typical S Dimensions

PLEASE CONSULT FACTORY FOR DIMENSIONS

√	Size	Steam In		Cond Out
		LBS	ANSI	ANSI
	S-22			
	S-2403	1985	10	3
	S-2404	2248	10	3
	S-2405	2518	12	4
	S-2406	2845	12	4
	S-2407	3272	14	4
	S-2408	3828	16	6
	S-2409	4632	16	6
	S-2410	5095	16	6
	S-2411	5570	18	8
	S-2412	6044	18	8
	S-2603	2510	10	3
	S-2604	2810	12	4
	S-2605	3120	12	4
	S-2606	3495	14	4
	S-2607	3950	16	6
	S-2608	4540	16	6
	S-2609	5310	18	6
	S-2610	6425	18	6
	S-2611	7030	18	6
	S-2612	7635	20	6

This Section is Intentionally Left Blank For Futur Data

Add 1/4 to dimension B for Double Wall



Typical **S** Dimensions

PLEASE CONSULT FACTORY FOR DIMENSIONS

√	Size	Steam In Cond Out		
		LBS	ANSI	ANSI
	S-2803	3130	12	4
	S-2804	3515	12	4
	S-2805	3900	14	4
	S-2806	4370	16	6
	S-2807	4935	16	6
	S-2808	5675	18	6
	S-2809	6640	18	6
	S-2810	8035	20	6
	S-2811	8790	22	8
	S-2812	9540	22	8

Add 1/4 to dimension B for Double Wall

DESIGN CONDITIONS (S16 to S28)			Notes: Units fabricated and tested in accordance with ASME Section VIII Division 1. Heat exchanger supports provided separately. All dimensions + / - 0.125".
	TUBE SIDE	SHELL SIDE	
DESIGN PRESSURE	150 Psig	150 Psig	
TEST PRESSURE	195 Psig	195 Psig	
DESIGN TEMPERATURE	375 °F	375 °F	
MIN METAL: TEMPERATURE	35 °F	35 °F	



Typical SE Dimensions

PLEASE CONSULT FACTORY FOR DIMENSIONS

✓	Size		Steam In	Cond Out
		LBS	ANSI	NPT
	SE-10			
	SE-12			
	SE-1403	695	6	2
	SE-1404	815	6	2
	SE-1405	935	8	2.5
	SE-1406	1055	8	2.5
	SE-1407	1180	8	2.5
	SE-1408	1300	8	2.5
	SE-1409	1420	8	2.5
	SE-1410	1540	8	2.5
	SE-1411	1661	8	2.5
	SE-1412	1781	8	2.5

This Section is Intentionally Left Blank For Futur Data

Add 1/4 to dimension B for Double Wall

DESIGN CONDITIONS (S10, S12 and S14)			Notes: Units fabricated and tested in accordance with ASME Section VIII Division 1. Heat exchanger supports provided separately. All dimensions + / - 0.125".
	TUBE SIDE	SHELL SIDE	
DESIGN PRESSURE	150 Psig	150 Psig	
TEST PRESSURE	195 Psig	195 Psig	
DESIGN TEMPERATURE	375 °F	375 °F	
MIN METAL: TEMPERATURE	35 °F	35 °F	



Typical SE Dimensions

PLEASE CONSULT FACTORY FOR DIMENSIONS

√	Size	Steam In		Cond Out
		LBS	ANSI	NPT
	SE-16			
	SE-18			
	SE-20			

This Section is Intentionally Left Blank For Futur Data

Add 1/4 to dimension B for Double Wall

DESIGN CONDITIONS (SE16, SE18 and SE20)			Notes: Units fabricated and tested in accordance with ASME Section VIII Division 1. Heat exchanger supports provided separately. All dimensions + / - 0.125".
	TUBE SIDE	SHELL SIDE	
DESIGN PRESSURE	- Psig	- Psig	
TEST PRESSURE	- Psig	- Psig	
DESIGN TEMPERATURE	- °F	- °F	
MIN METAL: TEMPERATURE	- °F	- °F	



Typical SE Dimensions

PLEASE CONSULT FACTORY FOR DIMENSIONS

✓	Size	Steam In		Cond Out
		LBS	ANSI	NPT
	SE-22			
	SE-24			
	SE-26			

This Section is Intentionally Left Blank For Futur Data

Add 1/4 to dimension B for Double Wall

DESIGN CONDITIONS (SE22, SE24 and SE26)			Notes: Units fabricated and tested in accordance with ASME Section VIII Division 1. Heat exchanger supports provided separately. All dimensions + / - 0.125".
	TUBE SIDE	SHELL SIDE	
DESIGN PRESSURE	- Psig	- Psig	
TEST PRESSURE	- Psig	- Psig	
DESIGN TEMPERATURE	- °F	- °F	
MIN METAL: TEMPERATURE	- °F	- °F	



Typical **SE** Dimensions

PLEASE CONSULT FACTORY FOR DIMENSIONS

✓	Size	Steam In			Cond Out		
		LBS	ANSI	NPT	LBS	ANSI	NPT
	SE-28						

This Section is Intentionally Left Blank For Futur Data

Add 1/4 to dimension B for Double Wall

DESIGN CONDITIONS (SE28)			Notes: Units fabricated and tested in accordance with ASME Section VIII Division 1. Heat exchanger supports provided separately. All dimensions + / - 0.125".
	TUBE SIDE	SHELL SIDE	
DESIGN PRESSURE	150 Psig	150 Psig	
TEST PRESSURE	195 Psig	195 Psig	
DESIGN TEMPERATURE	375 °F	375 °F	
MIN METAL: TEMPERATURE	35 °F	35 °F	



Typical **W** Dimensions

PLEASE CONSULT FACTORY FOR DIMENSIONS

√	Size	LBS	SHELL IN	SHELL OUT
			ANSI	ANSI
	W-1003	400	4	4
	W-1004	460	4	4
	W-1005	520	4	4
	W-1006	580	4	4
	W-1007	640	4	4
	W-1008	700	4	4
	W-1009	760	4	4
	W-1010	820	4	4
	W-1011	880	4	4
	W-1012	940	4	4
	W-1203	400	4	4
	W-1204	460	4	4
	W-1205	520	4	4
	W-1206	580	4	4
	W-1207	640	4	4
	W-1208	700	4	4
	W-1209	760	4	4
	W-1210	820	4	4
	W-1211	880	4	4
	W-1212	940	4	4

Add 1/4 to dimension B for Double Wall

DESIGN CONDITIONS (W4 to W12)			Notes: Units fabricated and tested in accordance with ASME Section VIII Division 1. Heat exchanger supports provided separately. All dimensions + / - 0.125".
	TUBE SIDE	SHELL SIDE	
DESIGN PRESSURE	125 Psig	150 Psig	
TEST PRESSURE	163 Psig	195 Psig	
DESIGN TEMPERATURE	375 °F	375 °F	
MIN METAL: TEMPERATURE	35 °F	35 °F	



Typical **W** Dimensions

PLEASE CONSULT FACTORY FOR DIMENSIONS

√	Size	LBS	SHELL IN	SHELL OUT
			ANSI	ANSI
	W-26			
	W-28			

This Section is Intentionally Left Blank For Futur Data

Add 1/4 to dimension B for Double Wall

DESIGN CONDITIONS (W14 to W28)			Notes: Units fabricated and tested in accordance with ASME Section VIII Division 1. Heat exchanger supports provided separately. All dimensions + / - 0.125".
	TUBE SIDE	SHELL SIDE	
DESIGN PRESSURE	150 Psig	150 Psig	
TEST PRESSURE	195 Psig	195 Psig	
DESIGN TEMPERATURE	375 °F	375 °F	
MIN METAL: TEMPERATURE	35 °F	35 °F	



Typical **WF** Dimensions

PLEASE CONSULT FACTORY FOR DIMENSIONS

✓	Size	SHELL IN		SHELL OUT
		LBS	NPT	NPT
	WF-04			
	WF-06			
	WF-0802	220	3	3
	WF-0803	260	3	3
	WF-0804	300	3	3
	WF-0805	340	3	3
	WF-0806	380	3	3
	WF-0807	420	3	3
	WF-0808	460	3	3
	WF-0809	500	3	3
	WF-0810	540	3	3
	WF-0811	580	3	3
	WF-0812	620	3	3

This Section is Intentionally Left Blank For Futur Data

Add 1/4 to dimension B for Double Wall



Typical **WF** Dimensions

PLEASE CONSULT FACTORY FOR DIMENSIONS

✓	Size		SHELL IN	SHELL OUT
		LBS	NPT	NPT
	WF-10			
	WF-12			
	WF-14			

This Section is Intentionally Left Blank For Futur Data

Add 1/4 to dimension B for Double Wall



Typical WF Dimensions

PLEASE CONSULT FACTORY FOR DIMENSIONS

√	Size	SHELL	SHELL
		IN	OUT
		LBS	NPT
	WF-16		
	WF-18		

This section is Intentionally Left Blank For Futur Data

Add 1/4 to dimension B for Double Wall

DESIGN CONDITIONS (WF04 to WF18)		Notes: Units fabricated and tested in accordance with ASME Section VIII Division 1. Heat exchanger supports provided separately. All dimensions + / - 0.125".	
	TUBE SIDE		SHELL SIDE
DESIGN PRESSURE	150 Psig		150 Psig
TEST PRESSURE	195 Psig		195 Psig
DESIGN TEMPERATURE	375 °F		375 °F
MIN METAL: TEMPERATURE	35 °F	35 °F	



Typical WF Dimensions

PLEASE CONSULT FACTORY FOR DIMENSIONS

✓	Size		SHELL IN	SHELL OUT
		LBS	NPT	NPT
	WF-20			
	WF-22			
	WF-24			

This Section is Intentionally Left Blank For Futur Data

Add 1/4 to dimension B for Double Wall



Typical **WF** Dimensions

PLEASE CONSULT FACTORY FOR DIMENSIONS

√	Size	LBS	SHELL IN	SHELL OUT
			NPT	NPT
	WF-26			
	WF-28			

This Section is Intentionally Left Blank For Futur Data

Add 1/4 to dimension B for Double Wall

DESIGN CONDITIONS (WF20 to WF28)			Notes: Units fabricated and tested in accordance with ASME Section VIII Division 1. Heat exchanger supports provided separately. All dimensions + / - 0.125".
	TUBE SIDE	SHELL SIDE	
DESIGN PRESSURE	150 Psig	150 Psig	
TEST PRESSURE	195 Psig	195 Psig	
DESIGN TEMPERATURE	375 °F	375 °F	
MIN METAL: TEMPERATURE	35 °F	35 °F	



SHELL AND TUBE - HEAT EXCHANGERS

Typical S Dimensions NEW GENERATION

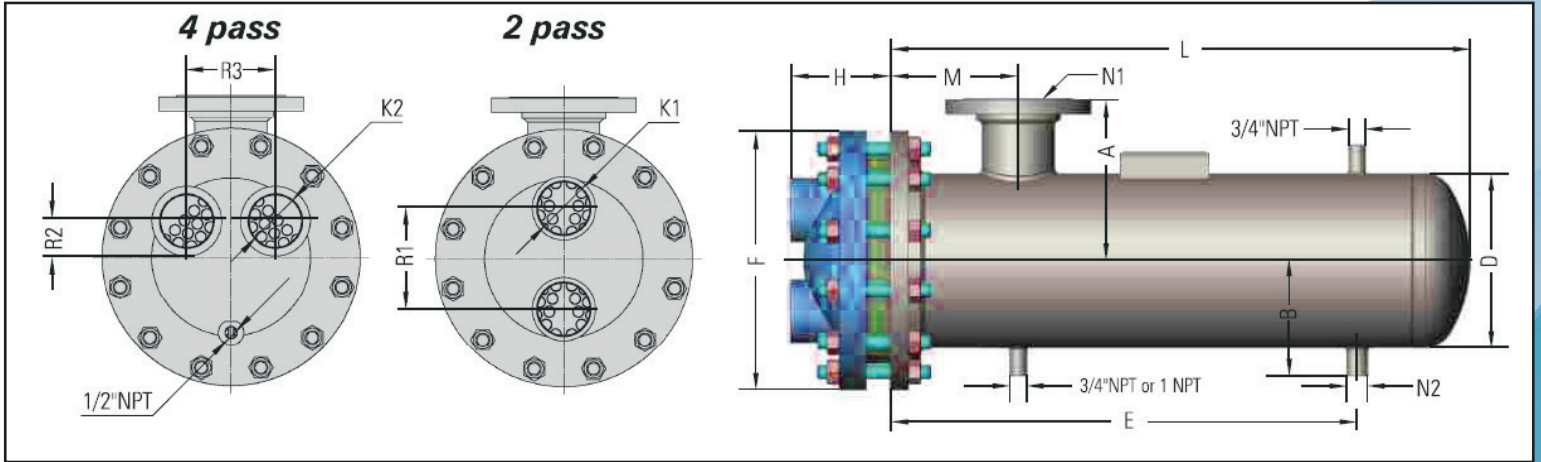

✓	Model #		Cast Iron Heads (in)					Dimensions (in) 2 Pass and 4 Pass										Htg. Surf. (sq.ft)
	2 Pass	4 Pass	2 Pass		4 Pass			D	F	M	E	B	A	L	N1	N2		
	4 inch		R1	K1 FNTF	R3	K2	R2	H										
	S042041	S044041									19 1/2		4	24 1/2				4.7
	S042042	S044042									31 1/2		4	36 1/2				6.9
	S042043	S044043									43 1/2		4	48 1/2				9.1
	S042044	S044044									55 1/2		4	60 1/2				11.3
	S042045	S044045	2 1/2	1 1/2	2 3/8	1	7/8	2 7/8	4 1/2	9	5	67 1/2	4	3 7/8	72 1/2	2"NPT	1"NPT	13.6
	S042046	S044046									79 1/2		3 3/4	84 1/2				15.8
	S042047	S044047									91 1/2		3 3/4	96 1/2				18
	S042048	S044048									103 1/2		3 3/4	108 1/2				20.3
	S042049	S044049									115 1/2		3 3/4	120 1/2				22.5
	6 inch																	
	S062061	S064061									18 1/2		4 7/8	25				10.7
	S062062	S064062									30 1/2		4 7/8	37				15.9
	S062063	S064063									42 1/2		5 3/4	49				21.1
	S062064	S064064									54 1/2		5 3/4	61				26.3
	S062065	S064065	4	2	3 3/4	1/2	1 1/4	3 7/16	6 5/8	11	5	66 1/2	4 7/8	5 9/16	73	3"NPT	1"NPT	31.5
	S062066	S064066									78 1/2		5 9/16	85				36.7
	S062067	S064067									90 1/2		5 9/16	97				41.9
	S062068	S064068									102 1/2		5 9/16	109				47.1
	S062069	S064069									114 1/2		5 9/16	121				52.3
	8 inch																	
	S082081	S084081									18		6	24	3"NPT	1"NPT		14.7
	S082082	S084082									30		6 7/8	36	3"NPT	1"NPT		22.7
	S082083	S084083									42		6 13/16	48	3"NPT	1"NPT		30.7
	S082084	S084084									54		8 7/8	60	4" Flange	1"NPT		38.7
	S082085	S084085	5	3	4	2	2	4 1/4	8 5/8	13 1/2	8	66	6	8 7/8	72	4" Flange	1 1/4"NPT	46.6
	S082086	S084086									78		8 7/8	84	4" Flange	1 1/4"NPT		54.6
	S082087	S084087									90		8 7/8	96	6" Flange	1 1/4"NPT		62.6
	S082088	S084088									102		8 7/8	108	6" Flange	1 1/4"NPT		70.6
	S082089	S084089									114		8 7/8	120	6" Flange	1 1/4"NPT		78.6
	10 inch																	
	S102101	S104101									17		7 15/16	24	4" Flange	1"NPT		23.7
	S102102	S104102									29		10	36	4" Flange	1"NPT		37.7
	S102103	S104103									41		10	48	4" Flange	1 1/4"NPT		51.5
	S102104	S104104									53		10	60	6" Flange	1 1/4"NPT		65.5
	S102105	S104105	6 1/4	3	5 1/2	3	2 1/4	4 7/8	10 3/4	16	8	65	7 1/8	10	72	6" Flange	1 1/2"NPT	79.4
	S102106	S104106									77		10	84	6" Flange	1 1/2"NPT		93.3
	S102107	S104107									88 1/2		10	96	6" Flange	2"NPT		107.2
	S102108	S104108									100 1/2		10	108	6" Flange	2"NPT		121.1
	S102109	S104109									112 1/2		10	120	6" Flange	2"NPT		135.1

Not Available for Double Wall



SHELL AND TUBE - HEAT EXCHANGERS

Typical S Dimensions NEW GENERATION

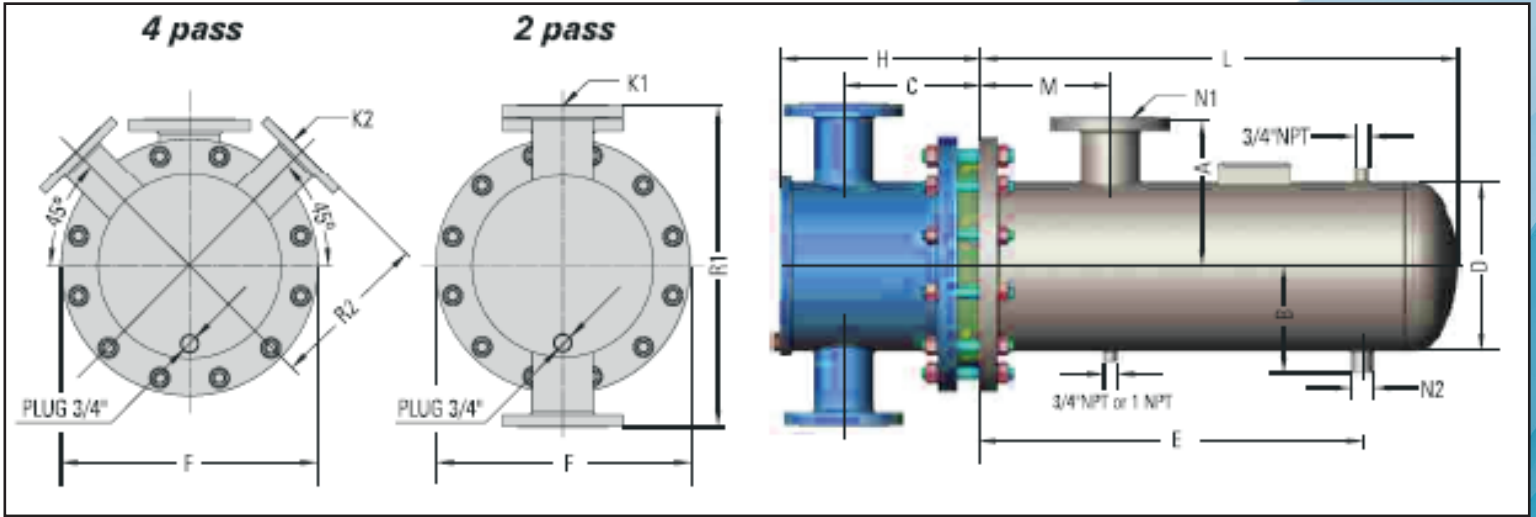

✓	Model #		Heads (in)					Dimensions (in) 2 Pass and 4 Pass								Htg. Surf. (sq.ft)		
	2 Pass	4 Pass	2 Pass		4 Pass			D	F	M	E	B	A	L	N1		N2	
	12 inch		R1	K1 FNTP	R2	K2	C	H										
	S122121	S124121	24	4" Flange	12	3" Flange	10 1/8	14 5/8	12 3/4	19	10	29	8 1/8	11	36 1/4	4" Flange	1 1/4"NPT	58.6
	S122122	S124122										41	8 1/8		48 1/4	6" Flange	1 1/4"NPT	79
	S122123	S124123										53	8 1/8		60 1/4	6" Flange	1 1/2"NPT	99.5
	S122124	S124124										65	8 1/8		72 1/4	6" Flange	2"NPT	119.9
	S122125	S124125										77	8 1/8		84 1/4	8" Flange	2"NPT	140.3
	S122126	S124126										88	9		96 1/4	8" Flange	2 1/2"NPT	160.8
	S122127	S124127										100	9		108 1/4	8" Flange	2 1/2"NPT	181.2
	S122128	S124128										112	9		120 1/4	8" Flange	2 1/2"NPT	201.6
	14 inch																	
	S142141	S144141	26	6" Flange	13	4" Flange	11 5/8	16 5/8	14	21	10	29	8 3/4	12	37 1/4	6" Flange	1 1/4"NPT	75.7
	S142142	S144142										40 1/2	8 3/4		49 1/4	6" Flange	2"NPT	102.4
	S142143	S144143										52 1/2	8 3/4		61 1/4	6" Flange	2"NPT	129.1
	S142144	S144144										64 1/2	8 3/4		73 1/4	8" Flange	2"NPT	155.8
	S142145	S144145										76	9 5/8		85 1/4	8" Flange	2 1/2"NPT	182.5
	S142146	S144146										88	9 5/8		97 1/4	8" Flange	2 1/2"NPT	209.2
	S142147	S144147										100	9 5/8		109 1/4	10" Flange	2 1/2"NPT	236
	S142148	S144148										112	9 5/8		121 1/4	10" Flange	3"NPT	262.7
	16 inch																	
	S162161	S164161	28 1/2	6" Flange	14 1/4	4" Flange	12 1/8	17 3/8	16	23 1/2	11	28 1/2	9 3/4	13	37	6" Flange	1 1/2"NPT	104.5
	S162162	S164162										40	9 3/4		49	6" Flange	2"NPT	141.4
	S162163	S164163										52	10 5/8		61	8" Flange	2 1/2"NPT	178.4
	S162164	S164164										64	10 5/8		73	8" Flange	2 1/2"NPT	215.3
	S162165	S164165										76	10 5/8		85	10" Flange	2 1/2"NPT	252.2
	S162166	S164166										87 1/2	10 5/8		97	10" Flange	3"NPT	289.1
	S162167	S164167										99 1/2	10 5/8		109	10" Flange	3"NPT	326
	S162168	S164168										111 1/2	10 5/8		121	10" Flange	3"NPT	363
	18 inch																	
	S182181	S184181	30	6" Flange	15	4" Flange	12 3/4	18	18	25	13	27 1/2	10 3/4	14	36 1/2	6" Flange	2"NPT	130.7
	S182182	S184182										39 1/2	10 3/4		48 1/2	8" Flange	2"NPT	177
	S182183	S184183										51	11 5/8		60 1/2	8" Flange	2 1/2"NPT	223.4
	S182184	S184184										62 1/2	11 5/8		72 1/2	10" Flange	3"NPT	269.7
	S182185	S184185										74 1/2	11 5/8		84 1/2	10" Flange	3"NPT	316.1
	S182186	S184186										86 1/2	11 5/8		96 1/2	10" Flange	3"NPT	362.4
	S182187	S184187										98 1/2	11 5/8		108 1/2	10" Flange	3"NPT	408.8
	S182188	S184188										110 1/2	12		120 1/2	10" Flange	4" Flange	455.1

Not Available for Double Wall



Typical S Dimensions NEW GENERATION

✓	Model #		Heads (in)					Dimensions (in) 2 Pass and 4 Pass								Htg. Surf. (sq.ft)		
	2 Pass	4 Pass	2 Pass		4 Pass			D	F	M	E	B	A	L	N1		N2	
			R1	K1 FNTP	R2	K2	C											H
20 inch																		
	S202201	S204201	32 1/2	6" Flange	16 1/4	4" Flange	14 1/8	19 5/8	20	27 1/2	13	27 1/2	15	15	36 3/4	8" Flange	8" Flange	163.9
	S202202	S204202										39	15	15	48 3/4	8" Flange	8" Flange	223.6
	S202203	S204203										50 1/2	15	15	60 3/4	10" Flange	10" Flange	283.3
	S202204	S204204										62 1/2	15	15	72 3/4	10" Flange	10" Flange	343
	S202205	S204205										74 1/2	15	15	84 3/4	12" Flange	12" Flange	402.7
	S202206	S204206										86 1/2	15	15	96 3/4	12" Flange	12" Flange	462.4
	S202207	S204207										98 1/2	15	15	108 3/4	12" Flange	12" Flange	522.2
	S202208	S204208										110 1/2	17	17	120 3/4	14" Flange	14" Flange	581.9
22 inch																		
	S222221	S224221	35	10" Flange	17 1/4	8" Flange	17	24 1/2	22	29 1/2	14	25 3/8	17	17	38 3/8	12" Flange	12" Flange	193.5
	S222222	S224222										37 3/8	17	17	50 3/8	12" Flange	12" Flange	265
	S222223	S224223										49 3/8	17	17	62 3/8	12" Flange	12" Flange	336.5
	S222224	S224224										61 3/8	17	17	74 3/8	12" Flange	12" Flange	408
	S222225	S224225										73 3/8	17	17	86 3/8	12" Flange	12" Flange	479.5
	S222226	S224226										85 3/8	17	17	98 3/8	12" Flange	12" Flange	551
	S222227	S224227										97 3/8	18	18	110 3/8	14" Flange	14" Flange	622.5
	S222228	S224228										109 3/8	18	18	122 3/8	14" Flange	14" Flange	694
24 inch																		
	S242241	S244241	37 1/2	10" Flange	18 1/2	8" Flange	17 7/8	25 5/8	24	32	14	25	18	18	38	12" Flange	12" Flange	236
	S242242	S244242										37	18	18	50	12" Flange	12" Flange	324
	S242243	S244243										49	18	18	62	12" Flange	12" Flange	412
	S242244	S244244										61	18	18	74	12" Flange	12" Flange	500
	S242245	S244245										73	18	18	86	12" Flange	12" Flange	588
	S242246	S244246										85	18	18	98	12" Flange	12" Flange	676
	S242247	S244247										97	19	19	110	14" Flange	14" Flange	764
	S242248	S244248										109	19	19	122	14" Flange	14" Flange	852
26 inch																		
	S262261	S264261	37	12" Flange	18 1/4	8" Flange	17	24 3/4	26	34 1/4	15	23 3/4	20	20	36	14" Flange	14" Flange	288.6
	S262262	S264262										25 3/4	20	20	48	14" Flange	14" Flange	393.4
	S262263	S264263										47 3/4	20	20	60	14" Flange	14" Flange	500.2
	S262264	S264264										59 3/4	20	20	72	14" Flange	14" Flange	607
	S262265	S264265										71 3/4	20	20	84	14" Flange	14" Flange	713.8
	S262266	S264266										83 3/4	20	20	96	14" Flange	14" Flange	820.6
	S262267	S264267										95 3/4	21	21	108	16" Flange	16" Flange	927.4
	S262268	S264268										107 3/4	21	21	120	16" Flange	16" Flange	1034.4
30 inch																		
	S302301	S304301	42	14" Flange	20 3/4	10" Flange	19 5/8	28 7/8	30	38 3/4	16	23	22	22	38 1/2	16" Flange	16" Flange	377.6
	S302302	S304302										35	22	22	50 1/2	16" Flange	16" Flange	520.5
	S302303	S304303										47	22	22	62 1/2	16" Flange	16" Flange	663.4
	S302304	S304304										59	22	22	74 1/2	16" Flange	16" Flange	806.3
	S302305	S304305										71	22	22	86 1/2	16" Flange	16" Flange	949.2
	S302306	S304306										83	22	22	98 1/2	16" Flange	16" Flange	1092
	S302307	S304307										95	22	22	110 1/2	18" Flange	18" Flange	1235
	S302308	S304308										107	22	22	122 1/2	18" Flange	18" Flange	1378

Not Available for Double Wall



SHELL AND TUBE - HEAT EXCHANGERS

Typical W Dimensions NEW GENERATION

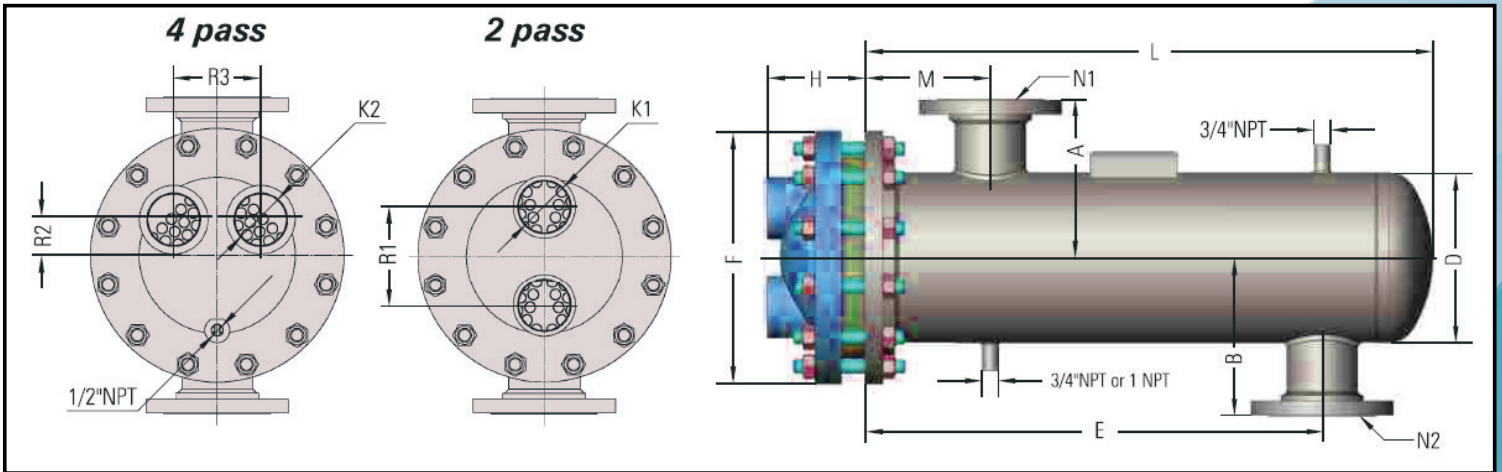

✓	Model #		Cast Iron Heads (in)					Dimensions (in) 2 Pass and 4 Pass										Htg. Surf. (sq.ft)
	2 Pass	4 Pass	2 Pass		4 Pass			D	F	M	E	B	A	L	N1	N2		
	4 inch		R1	K1 FNTP	R3	K2	R2	H										
	W042041	W044041									19 1/2			24 1/2				4.7
	W042042	W044042									31 1/2			36 1/2				6.9
	W042043	W044043									43 1/2			48 1/2				9.1
	W042044	W044044									55 1/2			60 1/2				11.3
	W042045	W044045	2 1/2	1 1/2	2 3/8	1	7/8	2 7/8	4 1/2	9	5	67 1/2	3 3/4	3 3/4	72 1/2	1 1/2"NPT	1 1/2"NPT	13.6
	W042046	W044046									79 1/2			84 1/2				15.8
	W042047	W044047									91 1/2			96 1/2				18
	W042048	W044048									103 1/2			108 1/2				20.3
	W042049	W044049									115 1/2			120 1/2				22.5
	6 inch																	
	W062061	W064061									18 1/2			25				10.7
	W062062	W064062									30 1/2			37				15.9
	W062063	W064063									42 1/2			49				21.1
	W062064	W064064									54 1/2			61				26.3
	W062065	W064065	4	2	3 3/4	1 1/2	1 1/4	3 7/16	6 5/8	11	5	66 1/2	4 7/8	4 7/8	73	2 1/2"NPT	2 1/2"NPT	31.5
	W062066	W064066									78 1/2			85				36.7
	W062067	W064067									90 1/2			97				41.9
	W062068	W064068									102 1/2			109				47.1
	W062069	W064069									114 1/2			121				52.3
	8 inch																	
	W082081	W084081									18			24				14.7
	W082082	W084082									30			36				22.7
	W082083	W084083									42			48				30.7
	W082084	W084084									54			60				38.7
	W082085	W084085	5	3	4	2	2	4 1/4	8 5/8	13 1/2	8	66	7 3/8	7 3/8	72	4"Flange	4"Flange	40.6
	W082086	W084086									78			84				54.6
	W082087	W084087									90			96				62.6
	W082088	W084088									102			108				70.6
	W082089	W084089									114			120				78.6
	10 inch																	
	W102101	W104101									17			24				23.7
	W102102	W104102									29			36				37.7
	W102103	W104103									41			48				51.5
	W102104	W104104									53			60				65.5
	W102105	W104105	6 1/4	3	5 1/2	3	2 1/4	4 7/8	10 3/4	16	8	65	8 1/2	8 1/2	72	4"Flange	4"Flange	79.4
	W102106	W104106									77			84				93.3
	W102107	W104107									88 1/2			96				107.2
	W102108	W104108									100 1/2			108				121.1
	W102109	W104109									112 1/2			120				135.1

Not Available for Double Wall



SHELL AND TUBE - HEAT EXCHANGERS

Typical W Dimensions NEW GENERATION

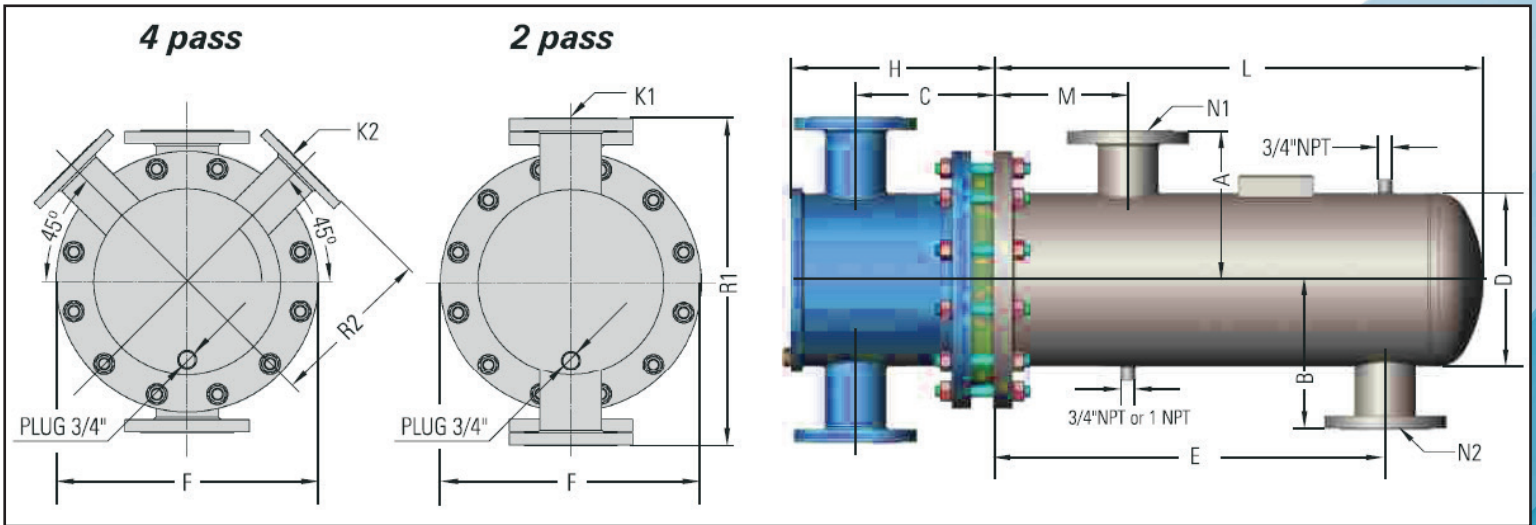

✓	Model #		Heads (in)				Dimensions (in) 2 Pass and 4 Pass							Htg. Surf. (sq.ft)				
	2 Pass	4 Pass	2 Pass		4 Pass		D	F	M	E	B	A	L		N1	N2		
	12 inch		R1	K1 FNTF	R2	K2	C	H										
	W122121	W124121	24	4"Flange	12	3"Flange	10 1/8	14 5/8	12 3/4	19	10	29	11	11	36 1/4	4"Flange	4"Flange	58.6
	W122122	W124122										41			48 1/4	6"Flange	6"Flange	79
	W122123	W124123										53			60 1/4	6"Flange	6"Flange	99.5
	W122124	W124124										65			72 1/4	6"Flange	6"Flange	119.9
	W122125	W124125										77			84 1/4	8"Flange	8"Flange	140.3
	W122126	W124126										88			96 1/4	8"Flange	8"Flange	160.8
	W122127	W124127										100			108 1/4	8"Flange	8"Flange	181.2
	W122128	W124128										112			120 1/4	8"Flange	8"Flange	201.6
	14 inch																	
	W142141	W144141	26	6"Flange	13	4"Flange	11 5/8	16 5/8	14	21	10	29	12	12	37 1/4	6"Flange	6"Flange	75.7
	W142142	W144142										40 1/2			49 1/4	6"Flange	6"Flange	102.4
	W142143	W144143										52 1/2			61 1/4	6"Flange	6"Flange	129.1
	W142144	W144144										64 1/2			73 1/4	8"Flange	8"Flange	155.8
	W142145	W144145										76			85 1/4	8"Flange	8"Flange	182.5
	W142146	W144146										88			97 1/4	8"Flange	8"Flange	209.2
	W142147	W144147										100			109 1/4	10"Flange	10"Flange	236
	W142148	W144148										112			121 1/4	10"Flange	10"Flange	262.7
	16 inch																	
	W162161	W164161	28 1/2	6"Flange	14 1/4	4"Flange	12 1/8	17 3/8	16	23 1/2	11	28 1/2	13	13	37	6"Flange	6"Flange	104.5
	W162162	W164162										40			49	6"Flange	6"Flange	141.4
	W162163	W164163										52			61	8"Flange	8"Flange	178.4
	W162164	W164164										64			73	8"Flange	8"Flange	215.3
	W162165	W164165										76			85	10"Flange	10"Flange	252.2
	W162166	W164166										87 1/2			97	10"Flange	10"Flange	289.1
	W162167	W164167										99 1/2			109	10"Flange	10"Flange	326
	W162168	W164168										111 1/2			121	10"Flange	10"Flange	363
	18 inch																	
	W182181	W184181	30	6"Flange	15	4"Flange	12 3/4	18	18	25	13	27 1/2	14	14	36 1/2	6"Flange	6"Flange	130.7
	W182182	W184182										39 1/2			48 1/2	8"Flange	8"Flange	177
	W182183	W184183										51			60 1/2	8"Flange	8"Flange	223.4
	W182184	W184184										62 1/2			72 1/2	10"Flange	10"Flange	269.7
	W182185	W184185										74 1/2			84 1/2	10"Flange	10"Flange	316.1
	W182186	W184186										86 1/2			96 1/2	10"Flange	10"Flange	362.4
	W182187	W184187										98 1/2			108 1/2	12"Flange	12"Flange	408.8
	W182188	W184188										110 1/2			120 1/2	12"Flange	12"Flange	455.1

Not Available for Double Wall



SHELL AND TUBE - HEAT EXCHANGERS

Typical W Dimensions NEW GENERATION

✓	Model #		Heads (in)						Dimensions (in) 2 Pass and 4 Pass								Htg. Surf. (sq.ft)	
	2 Pass	4 Pass	2 Pass		4 Pass				D	F	M	2 Pass and 4 Pass						
	20 inch		R1	K1 FNTF	R2	K2	C	H				E	B	A	L	N1		N2
	W202201	W204201	32 1/2	6" Flange	16 1/4	4" Flange	14 1/8	19 5/8	20	27 1/2	13	27 1/2	15	15	36 3/4	8" Flange	8" Flange	163.9
	W202202	W204202										39	15	15	48 3/4	8" Flange	8" Flange	223.6
	W202203	W204203										50 1/2	15	15	60 3/4	10" Flange	10" Flange	283.3
	W202204	W204204										62 1/2	15	15	72 3/4	10" Flange	10" Flange	343
	W202205	W204205										74 1/2	15	15	84 3/4	12" Flange	12" Flange	402.7
	W202206	W204206										86 1/2	15	15	96 3/4	12" Flange	12" Flange	462.4
	W202207	W204207										98 1/2	15	15	108 3/4	12" Flange	12" Flange	522.2
	W202208	W204208										110 1/2	17	17	120 3/4	14" Flange	14" Flange	581.9
	22 inch																	
	W222221	W224221	35	10" Flange	17 1/4	8" Flange	17	24 1/2	22	29 1/2	14	25 3/8	17	17	38 3/8	12" Flange	12" Flange	193.5
	W222222	W224222										37 3/8	17	17	50 3/8	12" Flange	12" Flange	265
	W222223	W224223										49 3/8	17	17	62 3/8	12" Flange	12" Flange	336.5
	W222224	W224224										61 3/8	17	17	74 3/8	12" Flange	12" Flange	408
	W222225	W224225										73 3/8	17	17	86 3/8	12" Flange	12" Flange	479.5
	W222226	W224226										85 3/8	17	17	98 3/8	12" Flange	12" Flange	551
	W222227	W224227										97 3/8	18	18	110 3/8	14" Flange	14" Flange	622.5
	W222228	W224228										109 3/8	18	18	122 3/8	14" Flange	14" Flange	694
	24 inch																	
	W242241	W244241	37 1/2	10" Flange	18 1/2	8" Flange	17 7/8	25 5/8	24	32	14	25	18	18	38	12" Flange	12" Flange	236
	W242242	W244242										37	18	18	50	12" Flange	12" Flange	324
	W242243	W244243										49	18	18	62	12" Flange	12" Flange	412
	W242244	W244244										61	18	18	74	12" Flange	12" Flange	500
	W242245	W244245										73	18	18	86	12" Flange	12" Flange	588
	W242246	W244246										85	18	18	98	12" Flange	12" Flange	676
	W242247	W244247										97	19	19	110	14" Flange	14" Flange	764
	W242248	W244248										109	19	19	122	14" Flange	14" Flange	852
	26 inch																	
	W262261	W264261	37	12" Flange	18 1/4	8" Flange	17	24 3/4	26	34 1/4	15	23 3/4	20	20	36	14" Flange	14" Flange	288.6
	W262262	W264262										25 3/4	20	20	48	14" Flange	14" Flange	393.4
	W262263	W264263										47 3/4	20	20	60	14" Flange	14" Flange	500.2
	W262264	W264264										59 3/4	20	20	72	14" Flange	14" Flange	607
	W262265	W264265										71 3/4	20	20	84	14" Flange	14" Flange	713.8
	W262266	W264266										83 3/4	20	20	96	14" Flange	14" Flange	820.6
	W262267	W264267										95 3/4	21	21	108	16" Flange	16" Flange	927.4
	W262268	W264268										107 3/4	21	21	120	16" Flange	16" Flange	1034.4
	30 inch																	
	W302301	W304301	42	14" Flange	20 3/4	10" Flange	19 5/8	28 7/8	30	38 3/4	16	23	22	22	38 1/2	16" Flange	16" Flange	377.6
	W302302	W304302										35	22	22	50 1/2	16" Flange	16" Flange	520.5
	W302303	W304303										47	22	22	62 1/2	16" Flange	16" Flange	663.4
	W302304	W304304										59	22	22	74 1/2	16" Flange	16" Flange	806.3
	W302305	W304305										71	22	22	86 1/2	16" Flange	16" Flange	949.2
	W302306	W304306										83	22	22	98 1/2	16" Flange	16" Flange	1092
	W302307	W304307										95	22	22	110 1/2	18" Flange	18" Flange	1235
	W302308	W304308										107	22	22	122 1/2	18" Flange	18" Flange	1378

Not Available for Double Wall



SHELL AND TUBE - HEAT EXCHANGERS



Design Parameters					
	Standard			Optional	
	Design Pressure (PSI)	Test Pressure (PSI)	Design Temperature (°F)	Design Pressure (PSI)	Design Temperature (°F)
Shell	150	300	375	300	421
 Tubes	150	300	375	400	448

Materials of Construction		
	Standard	Optional
Shell	Steel	Stainless Steel(304/316)
 Tubes	Stainless Steel	Copper, SS 316, 90/10
 Tubesheet	Steel	CuNi
 Connections	Steel	Stainless Steel(304/316)
 Head	Cast Iron / Steel	Stainless Steel(304/316)
 Gaskets	Non-abestos, pressed fiber	-

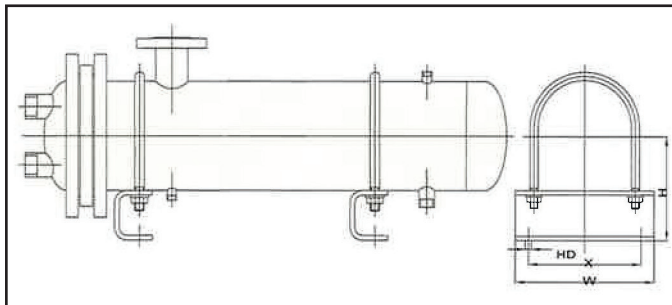

Unit Size	Dimensions			
	H	W	X	HD
4	5 1/4	6 15/16	5 1/2	1/2
6	6 5/16	9 1/4	7 1/2	5/8
8	7 5/16	11 1/4	9	5/8
10	8 3/8	13 5/8	10	3/4
12	9 3/8	15 5/8	11	3/4
14	10	17	12	3/4
16	12	19	13	3/4
18	13	21	14	3/4
20	14	23	14	3/4
22	17	25	18	7/8
24	18	27	19	7/8
26	19	30	20	7/8
30	21	33	22	7/8

Connection Types

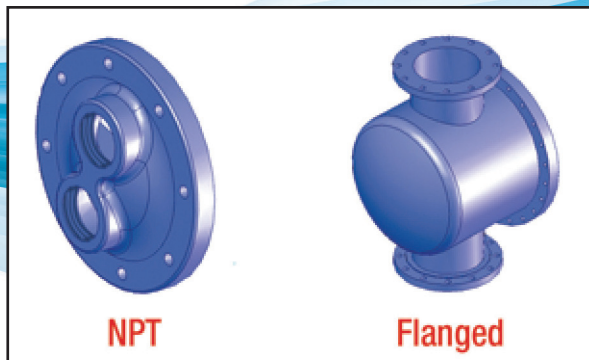

Typical S Connection Sizes

Model-Size	Tube Side -2 pass	-4 pass	Shell Side Inlet	Drain	Model-Size	Tube Side -2 pass	-4 pass	Shell Side Inlet	Drain
S-04	1.25	1	2	1	S-18	6	4	10	4
S-06	2	1.5	3	1	S-20	8	6	12	4
S-08	3	2	3	1	S-22	10	8	12	4
S-10	4	3	6	2	S-24	10	8	14	4
S-12	4	4	8	2	S-26	12	8	16	6
S-14	4	4	8	2.5	S-28	12	10	18	6
S-16	6	4	10	3	S-30	14	10	20	6

Please note that the model W is available upon request.

● Transfer Solutions

1) CONNECTIONS

Standardized sizes for easy assembly. Additional thread and surface protection for clean installation.

2) TUBESHEET

U-bend tubes expanded into tube-sheet allow for tube expansions and contractions due to thermal fluctuations.

3) GASKETS

High quality compressed fibers (reusable).

4) HEAD

Standard cast-iron or steel head for heavy duty services (also available as a spare part).

5) MOUNTING

Saddles attached with standard units for quick & easy mounting.

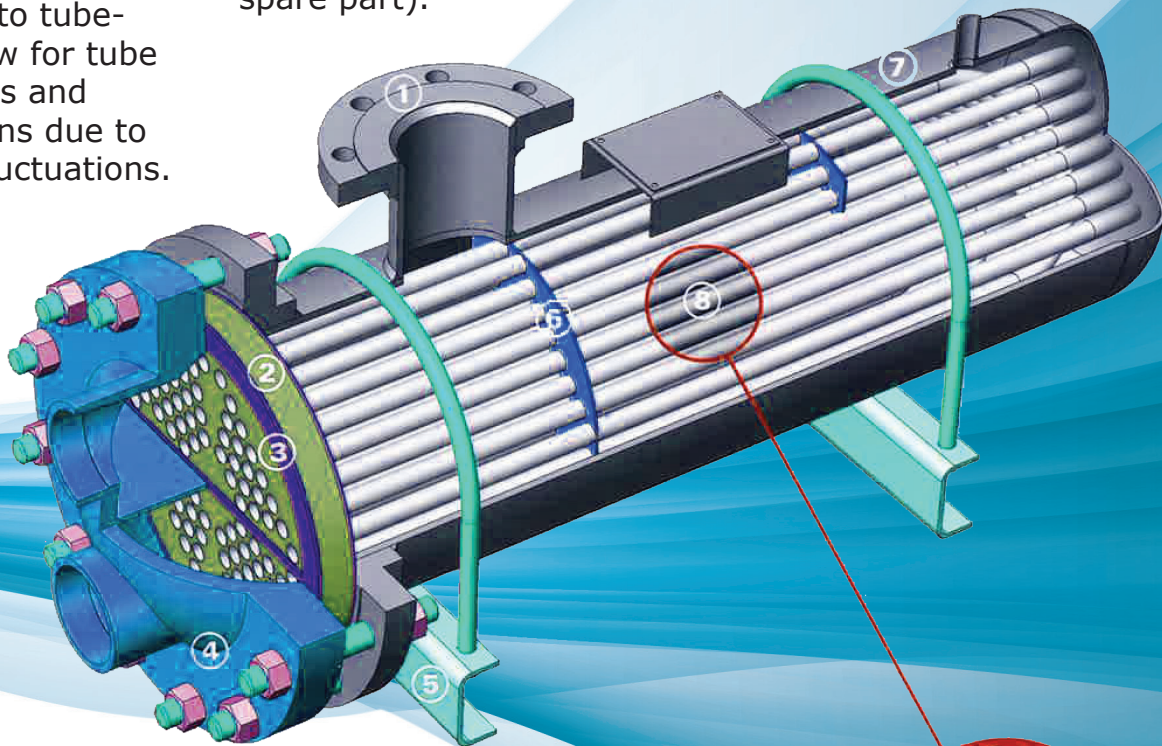

6) BAFFLES

Punched baffles with minimum clearances between tubes assure correct fluid flow and minimized bypass.

7) SHELL

Welded shell protected with high quality paint for corrosion resistance.

8) TUBE BUNDLE

Stainless steel tubes allow for strong, durable performance over a wide range of applications. Unique tube bundle layout minimizes buildup problems at the edges and optimizes media flow in the units.



“With over 35 years of experience in pressure vessel design and manufacture, our goal is to provide sustainable **energy saving solutions** that help make a greener HVAC world.”



Heavy Duty Construction

The Flo Fab heat exchanger is one of the most rugged heavy duty heat exchangers on the market. The circular shaped shell and tubes withstand greater pressures than flat plate designs with thinner materials. In accordance with safety codes, corrosion allowances are added to the carbon steel parts for added girth. The tubes are made of various corrosion resistant materials with thicknesses ranging from 20 BWG or 0.035” to 16 BWG or 0.065” making them at least 50% thicker than other heat transfer surfaces. With fewer gaskets, Flo Fab can withstand higher operating pressures and temperatures than other heat transfer devices.

Human Comfort

SDW and WDW double wall designs prevent potable water contact with chemically altered boiler water. The double wall construction provides a positive leak path between the potable water and the heating media should a leak occur in a tube wall. This design conforms to all US building code requirements.

Long Life Expectancy

Flo Fab utilizes U shaped tubes that are anchored at only one end. The tubes are allowed to expand freely in one direction when subject to changing operating temperatures and heat loads. This allows the heat exchanger to cycle with no risk of damage, which ensures a long, trouble-free life for the product.

Low Risk

Heavy duty construction, freely expanding corrosion resistant tubes and minimized use of gaskets make WesTube[®] a low risk investment. All units come certified by the appropriate safety code (ASME, CRN, etc).

Low Maintenance

FloFab heat exchangers are designed with fewer gaskets, which leads to less maintenance. For installations where hard water and scaling may occur, Flo Fab uses larger diameter tubes that can continue to operate and can be easily cleaned. If necessary, a bundle can be swapped out while the other is being serviced.

Lower Pumping Costs

The heat transfer surface in Flo Fab is smooth, resulting in less turbulent flow inside the tubes. This design maximizes heat transfer with reduced pressure drop, which lowers pumping costs.

Application Friendly

Flo Fab is used for heating domestic water, snow melting, pool heating, condensate cooling, district heating, radiant heating, comfort heating and other heat transfer systems where pressure separation is needed.



● Brazed - Heat Exchangers
BL Series

			
BL14	BL20	BL26	BL26C
			
BL50	BL95	BL120	BL190
			
BL200	BL600	BL100	BL210



● Product Dimensions

BL Series

Millimeters (mm)					Inches (in)				
√					√				
Model	BL14	BL20	BL26	BL26C	Model	BL14	BL20	BL26	BL26C
Width	78	76	111	124	Width	3,07	2,99	4,37	4,88
Height	206	310	310	304	Height	8,11	12,20	12,20	11,97
Length	9+2.3n	9+2.3n	10+2.36n	13+2.4n	Length	0.35+0.09n	0.35+0.09n	0.39+0.09n	0.51+0.09n
Horizontal Port Distance	42	42	50	70	Horizontal Port Distance	1,65	1,65	1,97	2,76
Vertical Port Distance	172	282	250	250	Vertical Port Distance	6,77	11,10	9,84	9,84
Max Pressure (Mpa)	3	3	3/4.5	3	Max Pressure (PSI)	435.11	435.11	435.11/652.66	435.11
Max Flowrate (M3/h)	3.6	3.6	8.1	8.1	Max Flowrate (USGPM)	15,85	15,85	35,67	35,67
Weight(kg)	0.6+0.6n	1.0+0.08n	1.3+0.12n	2.2+0.16n	Weight(lbs)	1.32+1.32n	2.20+0.18	2.87+0.26	4.85+0.35
√					√				
Model	BL50	BL95	BL120	BL190	Model	BL50	BL95	BL120	BL190
Width	111	191	246	307	Width	4,37	7,52	9,69	12,09
Height	525	616	528	696	Height	20,67	24,25	20,79	27,40
Length	10+2.35n	11+2.35n	13+2.36n	13+2.75n	Length	0.39+0.09n	0.43+0.09n	0.51+0.09n	0.51+0.11n
Horizontal Port Distance	50	92	174	179	Horizontal Port Distance	1,97	3,62	6,85	7,05
Vertical Port Distance	466	519	456	567	Vertical Port Distance	18,35	20,43	17,95	22,32
Max Pressure (Mpa)	3/4.5	3/4.5	3	3	Max Pressure (PSI)	435.11/652.66	435.11/652.66	435.11	435.11
Max Flowrate (M3/h)	12.7	39	42	100	Max Flowrate (USGPM)	55,92	171,74	184,95	44,35
Weight(kg)	2.6+0.19n	7.8+0.36n	7.2+0.52	12.5+0.72n	Weight(lbs)	5.73+0.42n	17.19+0.79n	15.87+1.15n	27.56+1.59n
√					√				
Model	BL200	BL600	BL100*	BL210*	Model	BL200	BL600	BL100*	BL210*
Width	321	429	248	322	Width	12,64	16,89	9,76	12,68
Height	738	1398	495	739	Height	29,06	55,04	19,49	29,09
Length	13+2.7n	22+2.78n	10+2.15n	13+2.55n	Length	0.51+0.11n	0.87+0.11n	0.39+0.09n	0.51+0.11n
Horizontal Port Distance	188	220	157	205,2	Horizontal Port Distance	7,40	8,66	6,18	8,08
Vertical Port Distance	603	1190	405	631	Vertical Port Distance	23,74	46,85	15,94	24,84
Max Pressure (Mpa)	2.1	1.5	3/4.5	3/4.5	Max Pressure (PSI)	304.58	217.56	435.11/652.66	435.11/652.66
Max Flowrate (M3/h)	100	300	42	100	Max Flowrate (USGPM)	440,35	1321,05	184,95	44,35
Weight(kg)	13+0.75n	31.8+1.73	6.5+0.37n	13+0.78n	Weight(lbs)	27.56+1.65n	70.11+3.81n	14.33+0.82n	28.66+1.72n

Product Specifications

BL14 Brazed Plate Heat Exchanger

General information

The BPHE is in principle built up by a plate package of corrugated channel plates between front and rear cover-plate packages. The cover plate packages consist of sealing plates, blind rings and cover plates. During the vacuum-brazing process, a brazed joint is formed at every contact point between two plates. The design creates a heat exchanger that consists of two separate circuits. The design options of the brazed heat exchanger are extensive. Different plate patterns are available for various duties and performance specifications. You can choose a standard configuration BHE, or a unit designed according to your own specific needs. The choice is entirely yours,

Typical applications

- HVAC heating/cooling
- Refrigerant applications
- Industrial cooling/heating
- Oil cooling

Working principles

The heating surface consists of thin corrugated metal plates stacked on top of each other. Channels are formed between the plates and corner ports are arranged so that the two media flow through alternate channels, usually in countercurrent flow for the most efficient heat transfer process.



Standard design

The plate pack is covered by cover plates. Connections are located in the front or rear cover plate. To improve the heat transfer design, the channel plates are corrugated.

Particulars required for quotation

To enable to make a specific quotation, specify the following particulars in your enquiry:

- Required flow rates or heat load
- Temperature program
- Physical properties of liquids in question
- Desired working pressure
- Maximum permitted pressure drop

Standard materials

Cover plates: 304 Stainless steel
 Connections: 304 Stainless steel
 Plates: 316L Stainless steel
 Brazing material: 99.99% Copper

Connections:



*Thread NPT / BST standard are all available.
 *More connections are available on request.

BPHE Plates and Channel Types

BPHEs are available with different types of channel plates were the herringbone pattern varies. The chevrons can be obtuse (high theta plate, D) or acute (low theta plate, X).

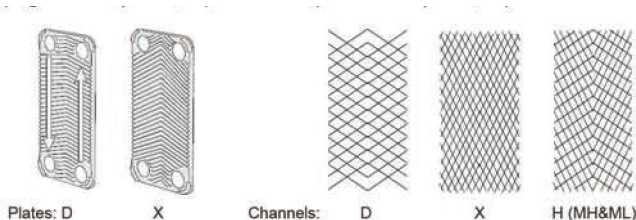

Component blow-up drawings:

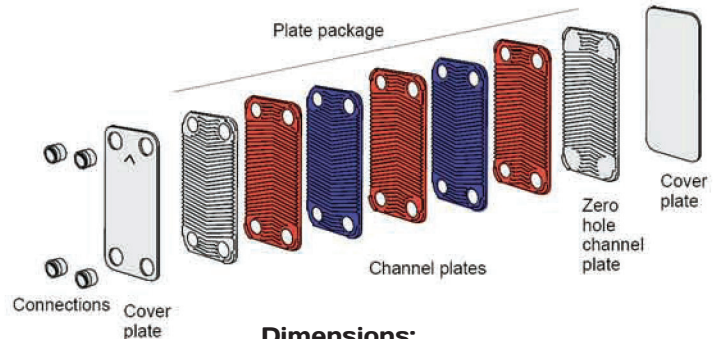

Dimensions:

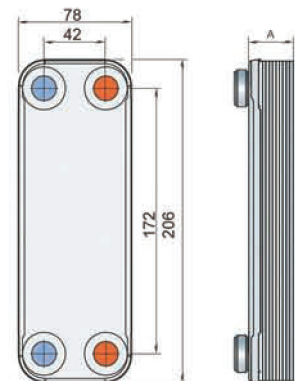

A measure mm = $9 + (2.3 * n)$ (+/-2 %)
 Weight** kg = $0.6 + (0.06 * n)$
 (n = number of plates) * Excluding connections

Standard Data

MAX WORKING TEMPERATURE	225°C
WORKING PRESSURE	0-30 bar
MAX FLOWRATE M3/H (GPM)	3.62(15.93)
MIN. NBR OF PLATES	4
MAX. NBR OF PLATES	100

FloFab reserves the right to change specifications without prior notification.



Product Specifications

BL20 Brazed Plate Heat Exchanger

General information

The BPHE is in principle built up by a plate package of corrugated channel plates between front and rear cover-plate packages. The cover plate packages consist of sealing plates, blind rings and cover plates. During the vacuum-brazing process, a brazed joint is formed at every contact point between two plates. The design creates a heat exchanger that consists of two separate circuits. The design options of the brazed heat exchanger are extensive. Different plate patterns are available for various duties and performance specifications. You can choose a standard configuration BHE, or a unit designed according to your own specific needs. The choice is entirely yours,

Typical applications

- HVAC heating/cooling
- Refrigerant applications
- Industrial cooling/heating
- Oil cooling

Working principles

The heating surface consists of thin corrugated metal plates stacked on top of each other. Channels are formed between the plates and corner ports are arranged so that the two media flow through alternate channels, usually in countercurrent flow for the most efficient heat transfer process.

Standard design

The plate pack is covered by cover plates. Connections are located in the front or rear cover plate. To improve the heat transfer design, the channel plates are corrugated.

Particulars required for quotation

To enable to make a specific quotation, specify the following particulars in your enquiry:

- Required flow rates or heat load
- Temperature program
- Physical properties of liquids in question
- Desired working pressure
- Maximum permitted pressure drop

Standard materials

Cover plates: 304 Stainless steel

Connections: 304 Stainless steel

Plates: 316L Stainless steel

Brazing material: 99.99% Copper

Connections:



*Thread NPT / BST standard are all available.
*More connections are available on request.

BPHE Plates and Channel Types

BPHEs are available with different types of channel plates where the herringbone pattern varies. The chevrons can be obtuse (high theta plate, D) or acute (low theta plate, X).

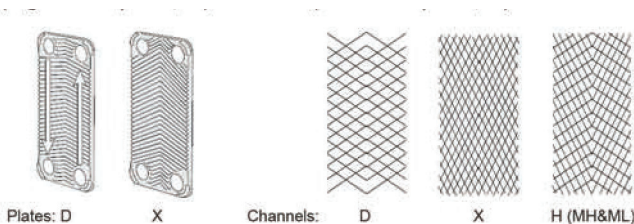

Component blow-up drawings:

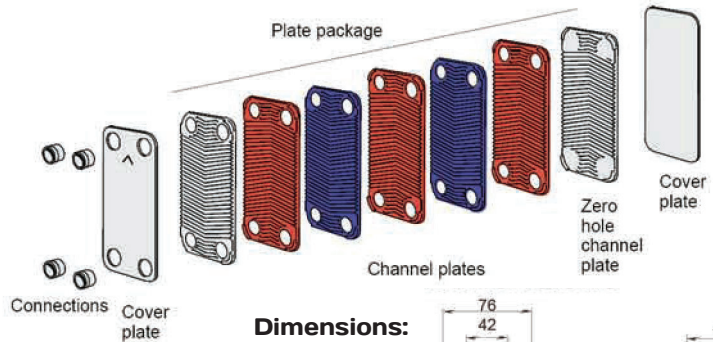

Dimensions:

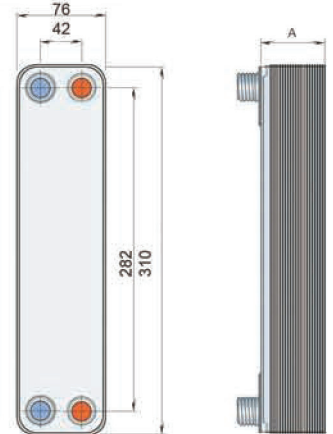

A measure mm = $9 + (2.3 * n)$ (+/-2 %)
Weight** kg = $1 + (0.08 * n)$
(n = number of plates) * Excluding connections

Standard Data

MAX WORKING TEMPERATURE	225°C
WORKING PRESSURE	0-30 bar
MAX FLOWRATE M3/H (GPM)	3.6(15.93)
MIN. NBR OF PLATES	4
MAX. NBR OF PLATES	100

FloFab reserves the right to change specifications without prior notification.

Product Specifications

BL26 Brazed Plate Heat Exchanger

General information

The BPHE is in principle built up by a plate package of corrugated channel plates between front and rear cover-plate packages. The cover plate packages consist of sealing plates, blind rings and cover plates. During the vacuum-brazing process, a brazed joint is formed at every contact point between two plates. The design creates a heat exchanger that consists of two separate circuits. The design options of the brazed heat exchanger are extensive. Different plate patterns are available for various duties and performance specifications. You can choose a standard configuration BHE, or a unit designed according to your own specific needs. The choice is entirely yours,

Typical applications

- HVAC heating/cooling
- Refrigerant applications
- Industrial cooling/heating
- Oil cooling

Working principles

The heating surface consists of thin corrugated metal plates stacked on top of each other. Channels are formed between the plates and corner ports are arranged so that the two media flow through alternate channels, usually in countercurrent flow for the most efficient heat transfer process.



Standard design

The plate pack is covered by cover plates. Connections are located in the front or rear cover plate. To improve the heat transfer design, the channel plates are corrugated.

Particulars required for quotation

To enable to make a specific quotation, specify the following particulars in your enquiry:

- Required flow rates or heat load
- Temperature program
- Physical properties of liquids in question
- Desired working pressure
- Maximum permitted pressure drop

Standard materials

Cover plates: 304 Stainless steel
 Connections: 304 Stainless steel
 Plates: 316L Stainless steel
 Brazing material: 99.99% Copper

Connections:



*Thread NPT / BST standard are all available.
 *More connections are available on request.

BPHE Plates and Channel Types

BPHEs are available with different types of channel plates were the herringbone pattern varies. The chevrons can be obtuse (high theta plate, D) or acute (low theta plate, X).

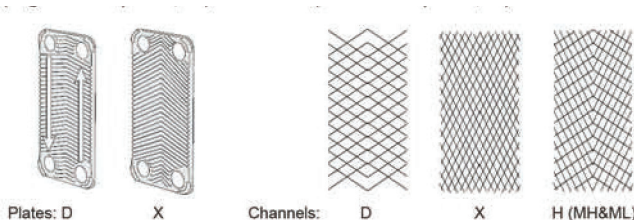

Component blow-up drawings:

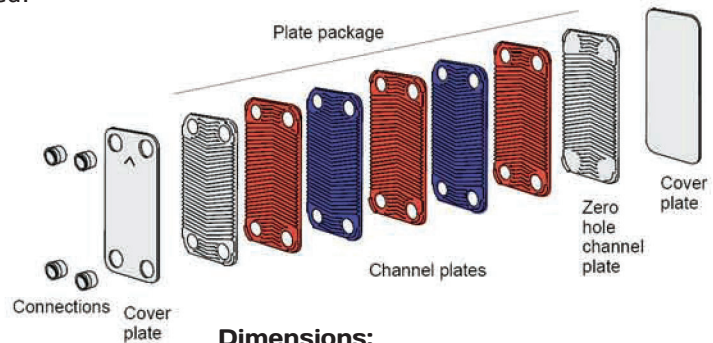

Dimensions:

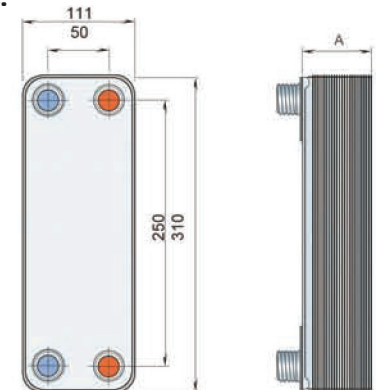

A measure mm = $10 + (2.36 * n)$ (+/-2%)
 Weight** kg = $1.3 + (0.12 * n)$
 (n = number of plates) * Excluding connections

Standard Data

MAX WORKING TEMPERATURE	225°C
WORKING PRESSURE	0-30 bar
MAX FLOWRATE M3/H (GPM)	8.1(35.84)
MIN. NBR OF PLATES	4
MAX. NBR OF PLATES	100

FloFab reserves the right to change specifications without prior notification.

Product Specifications

BL26C Brazed Plate Heat Exchanger

General information

The BPHE is in principle built up by a plate package of corrugated channel plates between front and rear cover-plate packages. The cover plate packages consist of sealing plates, blind rings and cover plates. During the vacuum-brazing process, a brazed joint is formed at every contact point between two plates. The design creates a heat exchanger that consists of two separate circuits. The design options of the brazed heat exchanger are extensive. Different plate patterns are available for various duties and performance specifications. You can choose a standard configuration BHE, or a unit designed according to your own specific needs. The choice is entirely yours,

Typical applications

- HVAC heating/cooling
- Refrigerant applications
- Industrial cooling/heating
- Oil cooling

Working principles

The heating surface consists of thin corrugated metal plates stacked on top of each other. Channels are formed between the plates and corner ports are arranged so that the two media flow through alternate channels, usually in countercurrent flow for the most efficient heat transfer process.



Standard design

The plate pack is covered by cover plates. Connections are located in the front or rear cover plate. To improve the heat transfer design, the channel plates are corrugated.

Particulars required for quotation

To enable to make a specific quotation, specify the following particulars in your enquiry:

- Required flow rates or heat load
- Temperature program
- Physical properties of liquids in question
- Desired working pressure
- Maximum permitted pressure drop

Standard materials

Cover plates: 304 Stainless steel

Connections: 304 Stainless steel

Plates: 316L Stainless steel

Brazing material: 99.99% Copper

Connections:

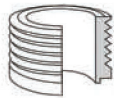

Male thread



Female thread



Flange



SAE flange



Welding

*Thread NPT / BST standard are all available.
*More connections are available on request.

BPHE Plates and Channel Types

BPHEs are available with different types of channel plates were the herringbone pattern varies. The chevrons can be obtuse (high theta plate, D) or acute (low theta plate, X).

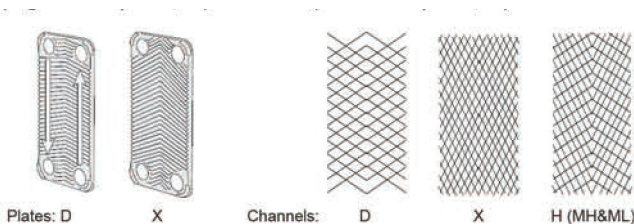

Component blow-up drawings:

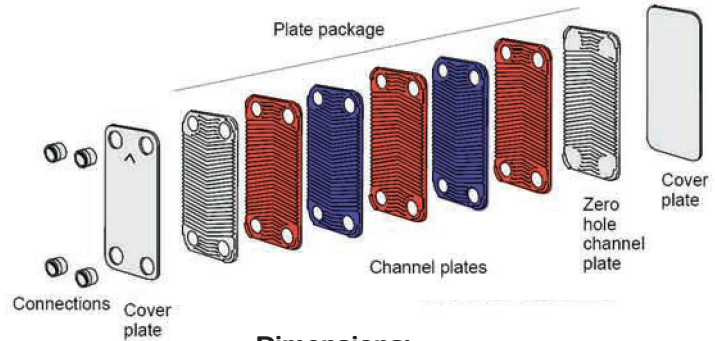

Dimensions:

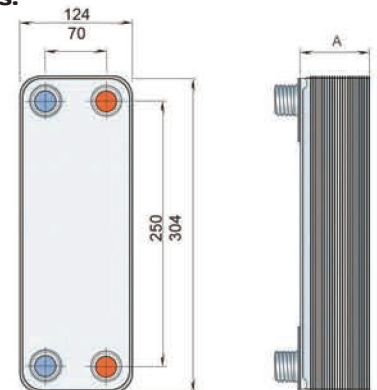

A measure mm = $13 + (2.4 * n)$ (+/-2%)
Weight** kg = $2.2 + (0.16 * n)$
(n = number of plates) * Excluding connections

Standard Data

MAX WORKING TEMPERATURE	225°C
WORKING PRESSURE	0-30 bar
MAX FLOWRATE M3/H (GPM)	8.1(35.84)
MIN. NBR OF PLATES	4
MAX. NBR OF PLATES	100

FloFab reserves the right to change specifications without prior notification.

Product Specifications

BL50 Brazen Plate Heat Exchanger

General information

The BPHE is in principle built up by a plate package of corrugated channel plates between front and rear cover-plate packages. The cover plate packages consist of sealing plates, blind rings and cover plates. During the vacuum-brazing process, a brazed joint is formed at every contact point between two plates. The design creates a heat exchanger that consists of two separate circuits. The design options of the brazed heat exchanger are extensive. Different plate patterns are available for various duties and performance specifications. You can choose a standard configuration BHE, or a unit designed according to your own specific needs. The choice is entirely yours,

Typical applications

- HVAC heating/cooling
- Refrigerant applications
- Industrial cooling/heating
- Oil cooling

Working principles

The heating surface consists of thin corrugated metal plates stacked on top of each other. Channels are formed between the plates and corner ports are arranged so that the two media flow through alternate channels, usually in countercurrent flow for the most efficient heat transfer process.

Standard design

The plate pack is covered by cover plates. Connections are located in the front or rear cover plate. To improve the heat transfer design, the channel plates are corrugated.

Particulars required for quotation

To enable to make a specific quotation, specify the following particulars in your enquiry:

- Required flow rates or heat load
- Temperature program
- Physical properties of liquids in question
- Desired working pressure
- Maximum permitted pressure drop

Standard materials

Cover plates: 304 Stainless steel
 Connections: 304 Stainless steel
 Plates: 316L Stainless steel
 Brazing material: 99.99% Copper

Connections:



*Thread NPT / BST standard are all available.
 *More connections are available on request.

BPHE Plates and Channel Types

BPHEs are available with different types of channel plates were the herringbone pattern varies. The chevrons can be obtuse (high theta plate, D) or acute (low theta plate, X).

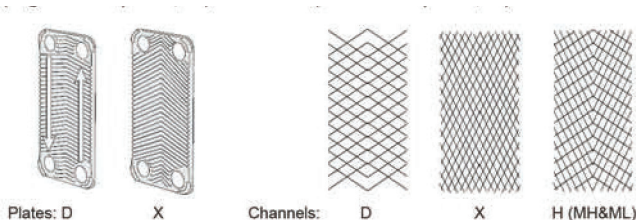

Component blow-up drawings:

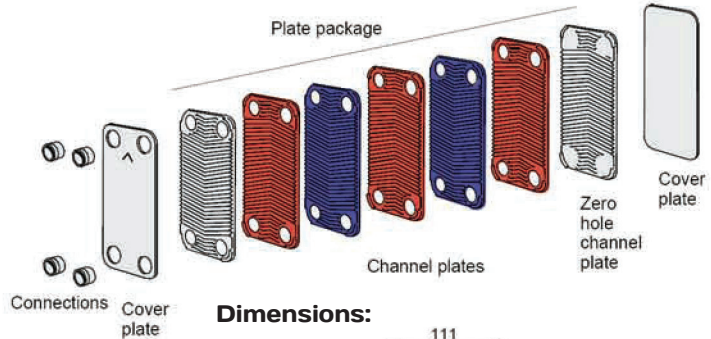

Dimensions:

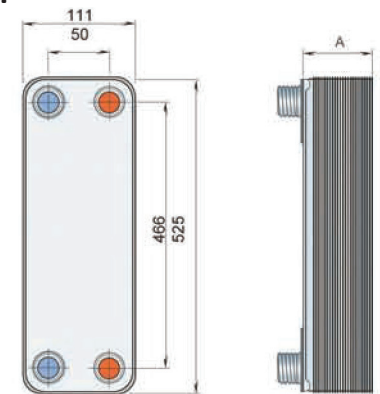

A measure mm = 10 + (2.35 * n) (+/-2%)
 Weight** kg = 2.6 + (0.19 * n)
 (n = number of plates) * Excluding connections

Standard Data

MAX WORKING TEMPERATURE	225°C
WORKING PRESSURE	0-30/45 bar
MAX FLOWRATE M3/H (GPM)	12.7(56.10)
MIN. NBR OF PLATES	4
MAX. NBR OF PLATES	150

FloFab reserves the right to change specifications without prior notification.

● Product Specifications

BL95 Brazed Plate Heat Exchanger

General information

The BPHE is in principle built up by a plate package of corrugated channel plates between front and rear cover-plate packages. The cover plate packages consist of sealing plates, blind rings and cover plates. During the vacuum-brazing process, a brazed joint is formed at every contact point between two plates. The design creates a heat exchanger that consists of two separate circuits. The design options of the brazed heat exchanger are extensive. Different plate patterns are available for various duties and performance specifications. You can choose a standard configuration BHE, or a unit designed according to your own specific needs. The choice is entirely yours,

Typical applications

- HVAC heating/cooling
- Refrigerant applications
- Industrial cooling/heating
- Oil cooling

Working principles

The heating surface consists of thin corrugated metal plates stacked on top of each other. Channels are formed between the plates and corner ports are arranged so that the two media flow through alternate channels, usually in countercurrent flow for the most efficient heat transfer process.

Standard design

The plate pack is covered by cover plates. Connections are located in the front or rear cover plate. To improve the heat transfer design, the channel plates are corrugated.

Particulars required for quotation

To enable to make a specific quotation, specify the following particulars in your enquiry:

- Required flow rates or heat load
- Temperature program
- Physical properties of liquids in question
- Desired working pressure
- Maximum permitted pressure drop

Standard materials

Cover plates: 304 Stainless steel

Connections: 304 Stainless steel

Plates: 316L Stainless steel

Brazing material: 99.99% Copper

Connections:

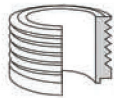

Male thread



Female thread



Flange



SAE flange



Welding

*Thread NPT / BST standard are all available.
*More connections are available on request.

BPHE Plates and Channel Types

BPHEs are available with different types of channel plates where the herringbone pattern varies. The chevrons can be obtuse (high theta plate, D) or acute (low theta plate, X).

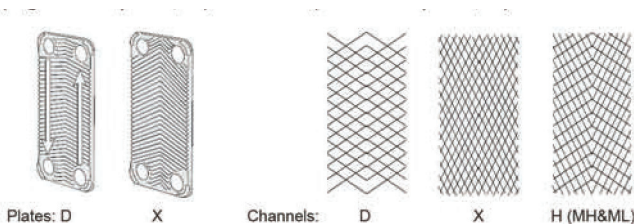

Component blow-up drawings:

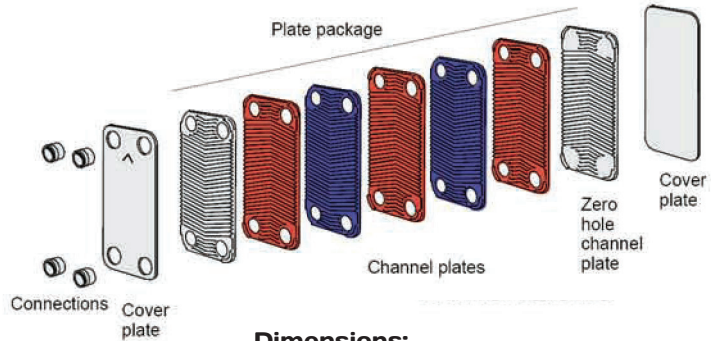

Dimensions:

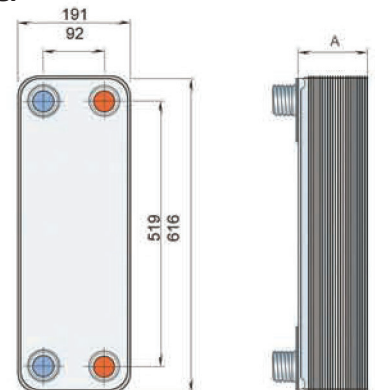

A measure mm = $11 + (2.35 * n)$ (+/-2 %)
Weight** kg = $7.0 + (0.36 * n)$
(n = number of plates) * Excluding connections

Standard Data

MAX WORKING TEMPERATURE	225°C
WORKING PRESSURE	0-30/45 bar
MAX FLOWRATE M3/H (GPM)	34(150)
MIN. NBR OF PLATES	4
MAX. NBR OF PLATES	190

FloFab reserves the right to change specifications without prior notification.

Product Specifications

BL100 Brazed Plate Heat Exchanger

General information

The BPHE is in principle built up by a plate package of corrugated channel plates between front and rear cover-plate packages. The cover plate packages consist of sealing plates, blind rings and cover plates. During the vacuum-brazing process, a brazed joint is formed at every contact point between two plates. The design creates a heat exchanger that consists of two separate circuits. The design options of the brazed heat exchanger are extensive. Different plate patterns are available for various duties and performance specifications. You can choose a standard configuration BHE, or a unit designed according to your own specific needs. The choice is entirely yours,

Typical applications

- HVAC heating/cooling
- Refrigerant applications
- Industrial cooling/heating
- Oil cooling

Working principles

The heating surface consists of thin corrugated metal plates stacked on top of each other. Channels are formed between the plates and corner ports are arranged so that the two media flow through alternate channels, usually in countercurrent flow for the most efficient heat transfer process.

Standard design

The plate pack is covered by cover plates. Connections are located in the front or rear cover plate. To improve the heat transfer design, the channel plates are corrugated.

Particulars required for quotation

To enable to make a specific quotation, specify the following particulars in your enquiry:

- Required flow rates or heat load
- Temperature program
- Physical properties of liquids in question
- Desired working pressure
- Maximum permitted pressure drop

Standard materials

Cover plates: 304 Stainless steel
 Connections: 304 Stainless steel
 Plates: 316L Stainless steel
 Brazing material: 99.99% Copper

Connections:



*Thread NPT / BST standard are all available.
 *More connections are available on request.

BPHE Plates and Channel Types

BPHEs are available with different types of channel plates where the herringbone pattern varies. The chevrons can be obtuse (high theta plate, D) or acute (low theta plate, X).

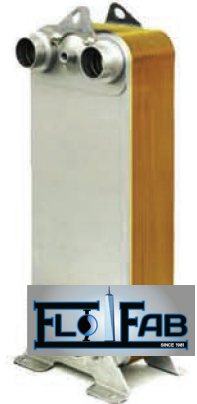
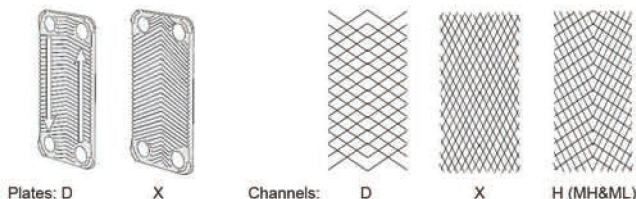

Component blow-up drawings:

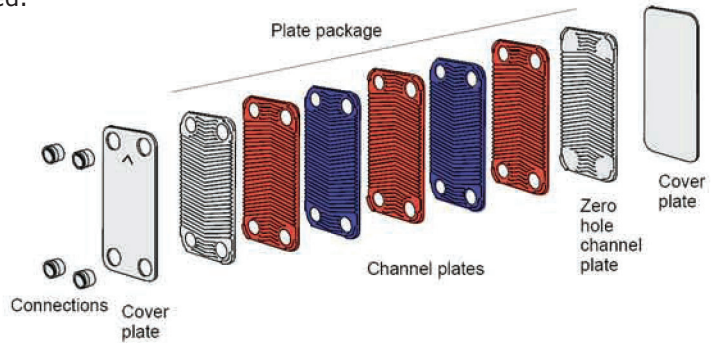

Dimensions:

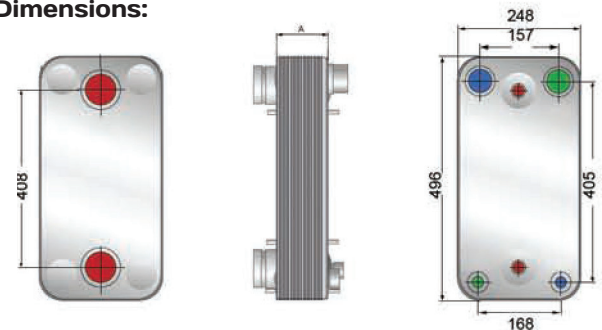

A measure mm = 10+ (2.15 * n) (+/-2 %)
 Weight** kg = 6.5 + (0.37 * n)
 (n = number of plates) * Excluding connections

Standard Data

MAX WORKING TEMPERATURE	225°C
WORKING PRESSURE	0-30/45 bar
MAX FLOWRATE M3/H (GPM)	42(185)
MIN. NBR OF PLATES	10
MAX. NBR OF PLATES	150

FloFab reserves the right to change specifications without prior notification.

Product Specifications

BL120 Brazed Plate Heat Exchanger

General information

The BPHE is in principle built up by a plate package of corrugated channel plates between front and rear cover-plate packages. The cover plate packages consist of sealing plates, blind rings and cover plates. During the vacuum-brazing process, a brazed joint is formed at every contact point between two plates. The design creates a heat exchanger that consists of two separate circuits. The design options of the brazed heat exchanger are extensive. Different plate patterns are available for various duties and performance specifications. You can choose a standard configuration BHE, or a unit designed according to your own specific needs. The choice is entirely yours,

Typical applications

- HVAC heating/cooling
- Refrigerant applications
- Industrial cooling/heating
- Oil cooling

Working principles

The heating surface consists of thin corrugated metal plates stacked on top of each other. Channels are formed between the plates and corner ports are arranged so that the two media flow through alternate channels, usually in countercurrent flow for the most efficient heat transfer process.

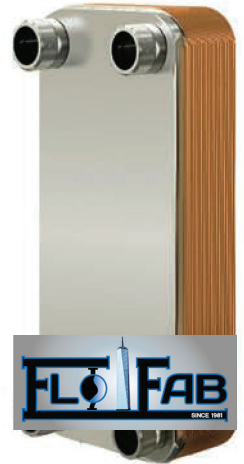

Standard design

The plate pack is covered by cover plates. Connections are located in the front or rear cover plate. To improve the heat transfer design, the channel plates are corrugated.

Particulars required for quotation

To enable to make a specific quotation, specify the following particulars in your enquiry:

- Required flow rates or heat load
- Temperature program
- Physical properties of liquids in question
- Desired working pressure
- Maximum permitted pressure drop

Standard materials

Cover plates: 304 Stainless steel

Connections: 304 Stainless steel

Plates: 316L Stainless steel

Brazing material: 99.99% Copper

Connections:

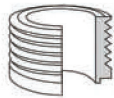

Male thread



Female thread



Flange



SAE flange



Welding

*Thread NPT / BST standard are all available.
*More connections are available on request.

BPHE Plates and Channel Types

BPHEs are available with different types of channel plates where the herringbone pattern varies. The chevrons can be obtuse (high theta plate, D) or acute (low theta plate, X).

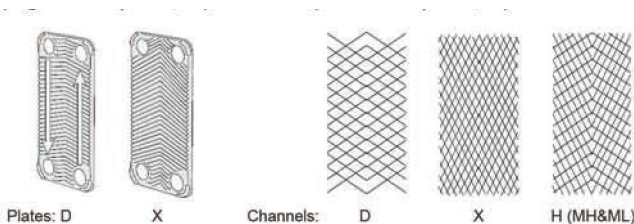

Component blow-up drawings:

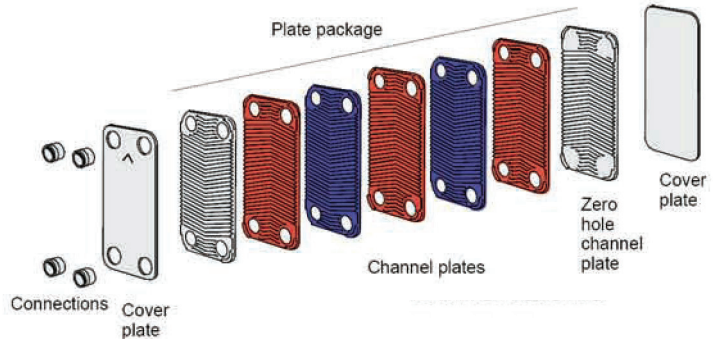

Dimensions:

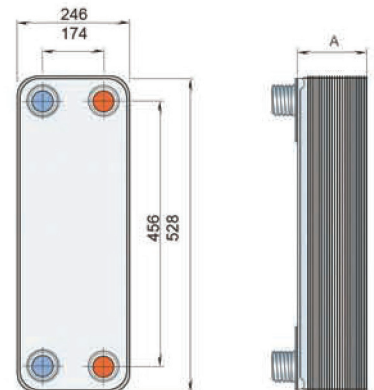

A measure mm = $13 + (2.36 * n)$ (+/-2%)
Weight** kg = $7.2 + (0.52 * n)$
(n = number of plates) * Excluding connections

Standard Data

MAX WORKING TEMPERATURE	225°C
WORKING PRESSURE	0-30/45 bar
MAX FLOWRATE M3/H (GPM)	42(185)
MIN. NBR OF PLATES	4
MAX. NBR OF PLATES	150

FloFab reserves the right to change specifications without prior notification.

Product Specifications

BL190 Brazed Plate Heat Exchanger

General information

The BPHE is in principle built up by a plate package of corrugated channel plates between front and rear cover-plate packages. The cover plate packages consist of sealing plates, blind rings and cover plates. During the vacuum-brazing process, a brazed joint is formed at every contact point between two plates. The design creates a heat exchanger that consists of two separate circuits. The design options of the brazed heat exchanger are extensive. Different plate patterns are available for various duties and performance specifications. You can choose a standard configuration BHE, or a unit designed according to your own specific needs. The choice is entirely yours,

Typical applications

- HVAC heating/cooling
- Refrigerant applications
- Industrial cooling/heating
- Oil cooling

Working principles

The heating surface consists of thin corrugated metal plates stacked on top of each other. Channels are formed between the plates and corner ports are arranged so that the two media flow through alternate channels, usually in countercurrent flow for the most efficient heat transfer process.

Standard design

The plate pack is covered by cover plates. Connections are located in the front or rear cover plate. To improve the heat transfer design, the channel plates are corrugated.

Particulars required for quotation

To enable to make a specific quotation, specify the following particulars in your enquiry:

- Required flow rates or heat load
- Temperature program
- Physical properties of liquids in question
- Desired working pressure
- Maximum permitted pressure drop

Standard materials

Cover plates: 304 Stainless steel
 Connections: 304 Stainless steel
 Plates: 316L Stainless steel
 Brazing material: 99.99% Copper

Connections:



*Thread NPT / BST standard are all available.
 *More connections are available on request.

BPHE Plates and Channel Types

BPHEs are available with different types of channel plates where the herringbone pattern varies. The chevrons can be obtuse (high theta plate, D) or acute (low theta plate, X).

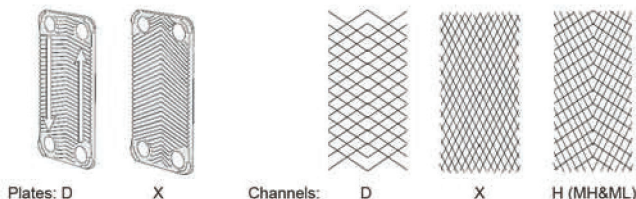

Component blow-up drawings:

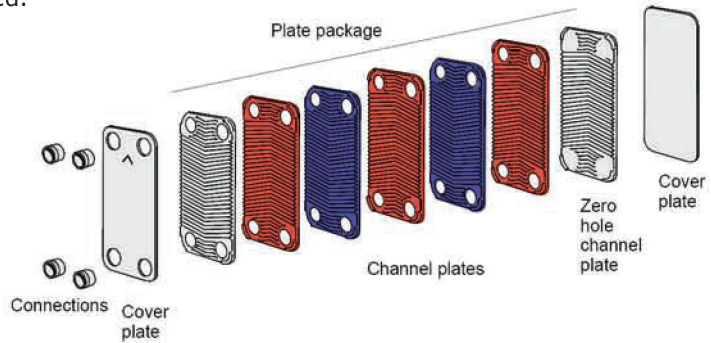

Dimensions:

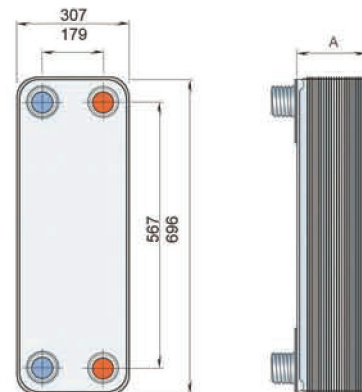

A measure mm = $13 + (2.75 * n)$ (+/-2 %)
 Weight** kg = $12.5 + (0.72 * n)$
 (n = number of plates) * Excluding connections

Standard Data

MAX WORKING TEMPERATURE	225°C
WORKING PRESSURE	0-30bar
MAX FLOWRATE M3/H (GPM)	100(440)
MIN. NBR OF PLATES	4
MAX. NBR OF PLATES	150

FloFab reserves the right to change specifications without prior notification.



● Product Specifications

BL200 Brazed Plate Heat Exchanger

General information

The BPHE is in principle built up by a plate package of corrugated channel plates between front and rear cover-plate packages. The cover plate packages consist of sealing plates, blind rings and cover plates. During the vacuum-brazing process, a brazed joint is formed at every contact point between two plates. The design creates a heat exchanger that consists of two separate circuits. The design options of the brazed heat exchanger are extensive. Different plate patterns are available for various duties and performance specifications. You can choose a standard configuration BHE, or a unit designed according to your own specific needs. The choice is entirely yours,

Typical applications

- HVAC heating/cooling
- Refrigerant applications
- Industrial cooling/heating
- Oil cooling

Working principles

The heating surface consists of thin corrugated metal plates stacked on top of each other. Channels are formed between the plates and corner ports are arranged so that the two media flow through alternate channels, usually in countercurrent flow for the most efficient heat transfer process.

Standard design

The plate pack is covered by cover plates. Connections are located in the front or rear cover plate. To improve the heat transfer design, the channel plates are corrugated.

Particulars required for quotation

To enable to make a specific quotation, specify the following particulars in your enquiry:

- Required flow rates or heat load
- Temperature program
- Physical properties of liquids in question
- Desired working pressure
- Maximum permitted pressure drop

Standard materials

Cover plates: 304 Stainless steel

Connections: 304 Stainless steel

Plates: 316L Stainless steel

Brazing material: 99.99% Copper

Connections:



*Thread NPT / BST standard are all available.
*More connections are available on request.

BPHE Plates and Channel Types

BPHEs are available with different types of channel plates were the herringbone pattern varies. The chevrons can be obtuse (high theta plate, D) or acute (low theta plate, X).

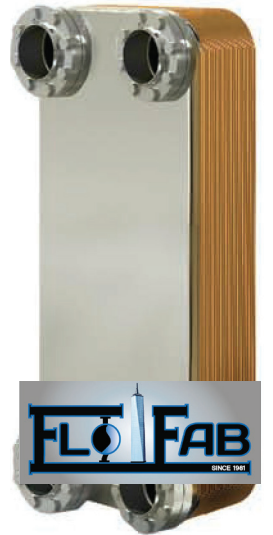
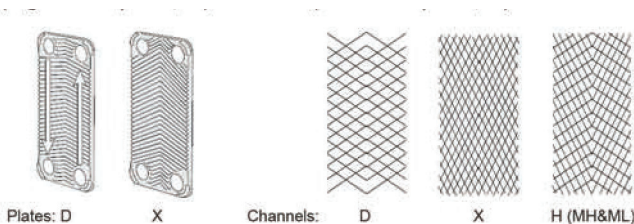

Component blow-up drawings:

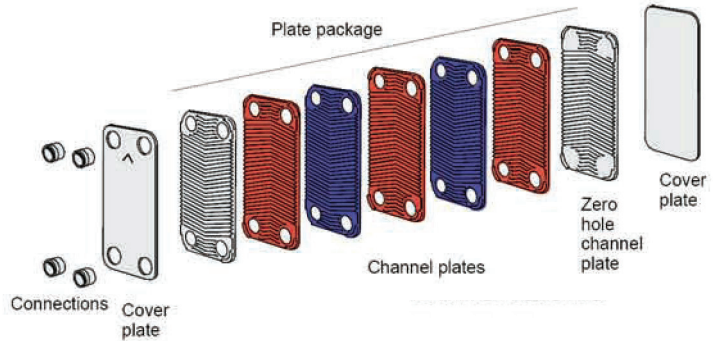

Dimensions:

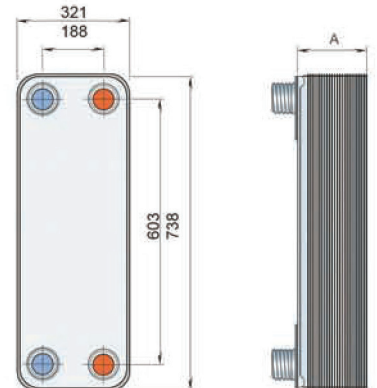

A measure mm = $13 + (2.7 * n)$ (+/-2 %)
Weight** kg = $13 + (0.75 * n)$
(n = number of plates) * Excluding connections

Standard Data

MAX WORKING TEMPERATURE	225°C
WORKING PRESSURE	0-21 bar
MAX FLOWRATE M3/H (GPM)	100(440)
MIN. NBR OF PLATES	10
MAX. NBR OF PLATES	200

FloFab reserves the right to change specifications without prior notification.

Product Specifications

BL210 Brazed Plate Heat Exchanger

General information

The BPHE is in principle built up by a plate package of corrugated channel plates between front and rear cover-plate packages. The cover plate packages consist of sealing plates, blind rings and cover plates. During the vacuum-brazing process, a brazed joint is formed at every contact point between two plates. The design creates a heat exchanger that consists of two separate circuits. The design options of the brazed heat exchanger are extensive. Different plate patterns are available for various duties and performance specifications. You can choose a standard configuration BHE, or a unit designed according to your own specific needs. The choice is entirely yours,

Typical applications

- HVAC heating/cooling
- Refrigerant applications
- Industrial cooling/heating
- Oil cooling

Working principles

The heating surface consists of thin corrugated metal plates stacked on top of each other. Channels are formed between the plates and corner ports are arranged so that the two media flow through alternate channels, usually in countercurrent flow for the most efficient heat transfer process.

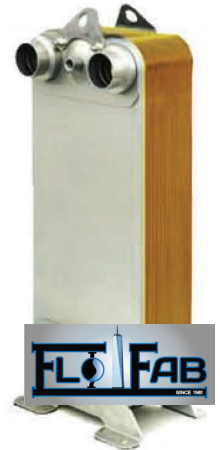

Standard design

The plate pack is covered by cover plates. Connections are located in the front or rear cover plate. To improve the heat transfer design, the channel plates are corrugated.

Particulars required for quotation

To enable to make a specific quotation, specify the following particulars in your enquiry:

- Required flow rates or heat load
- Temperature program
- Physical properties of liquids in question
- Desired working pressure
- Maximum permitted pressure drop

Standard materials

Cover plates: 304 Stainless steel
 Connections: 304 Stainless steel
 Plates: 316L Stainless steel
 Brazing material: 99.99% Copper

Connections:



*Thread NPT / BST standard are all available.
 *More connections are available on request.

BPHE Plates and Channel Types

BPHEs are available with different types of channel plates where the herringbone pattern varies. The chevrons can be obtuse (high theta plate, D) or acute (low theta plate, X).

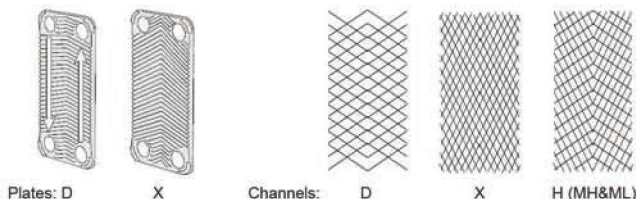

Component blow-up drawings:

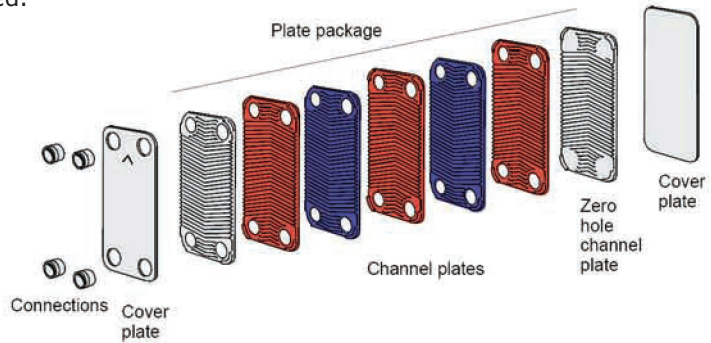

Dimensions:

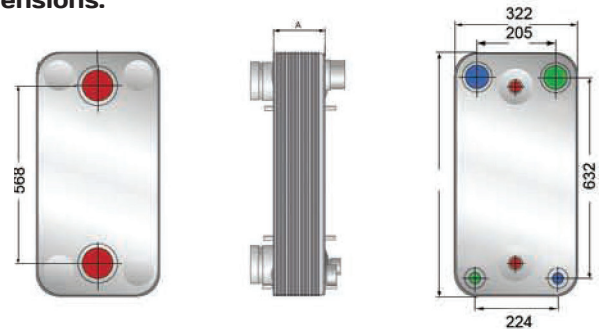

A measure mm = $13 + (2.55 * n)$ (+/-2 %)
 Weight** kg = $13 + (0.78 * n)$
 (n = number of plates) * Excluding connections

Standard Data

MAX WORKING TEMPERATURE	225°C
WORKING PRESSURE	0-30/45bar
MAX FLOWRATE M3/H (GPM)	42(185)
MIN. NBR OF PLATES	100
MAX. NBR OF PLATES	190

FloFab reserves the right to change specifications without prior notification.

Product Specifications

BL600 Brazed Plate Heat Exchanger

General information

The BPHE is in principle built up by a plate package of corrugated channel plates between front and rear cover-plate packages. The cover plate packages consist of sealing plates, blind rings and cover plates. During the vacuum-brazing process, a brazed joint is formed at every contact point between two plates. The design creates a heat exchanger that consists of two separate circuits. The design options of the brazed heat exchanger are extensive. Different plate patterns are available for various duties and performance specifications. You can choose a standard configuration BHE, or a unit designed according to your own specific needs. The choice is entirely yours,

Typical applications

- HVAC heating/cooling
- Refrigerant applications
- Industrial cooling/heating
- Oil cooling

Working principles

The heating surface consists of thin corrugated metal plates stacked on top of each other. Channels are formed between the plates and corner ports are arranged so that the two media flow through alternate channels, usually in countercurrent flow for the most efficient heat transfer process.

Standard design

The plate pack is covered by cover plates. Connections are located in the front or rear cover plate. To improve the heat transfer design, the channel plates are corrugated.

Particulars required for quotation

To enable to make a specific quotation, specify the following particulars in your enquiry:

- Required flow rates or heat load
- Temperature program
- Physical properties of liquids in question
- Desired working pressure
- Maximum permitted pressure drop

Standard materials

Cover plates: 304 Stainless steel

Connections: 304 Stainless steel

Plates: 316L Stainless steel

Brazing material: 99.99% Copper

Connections:



Male thread



Female thread



Flange



SAE flange



Welding

*Thread NPT / BST standard are all available.
*More connections are available on request.

BPHE Plates and Channel Types

BPHEs are available with different types of channel plates where the herringbone pattern varies. The chevrons can be obtuse (high theta plate, D) or acute (low theta plate, X).

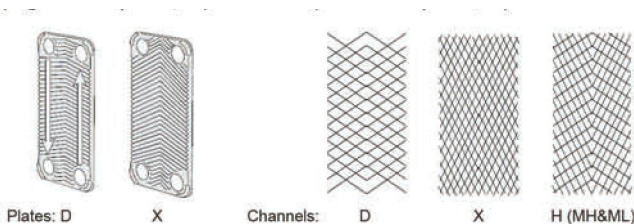

Component blow-up drawings:

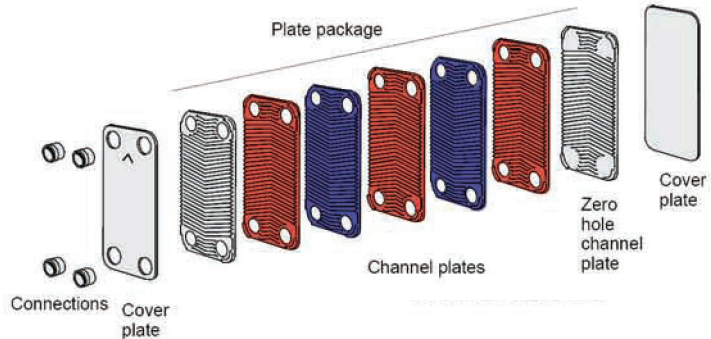

Dimensions:

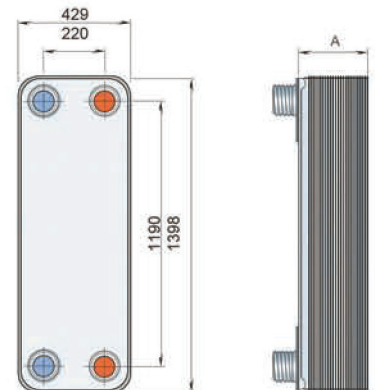

A measure mm = $22 + (2.78 * n) (+/- 2 \%)$
Weight** kg = $31.8 + (1.73 * n)$
(n = number of plates) * Excluding connections

Standard Data

MAX WORKING TEMPERATURE	225°C
WORKING PRESSURE	0-20 bar
MAX FLOWRATE M3/H (GPM)	300(1,320)
MIN. NBR OF PLATES	10
MAX. NBR OF PLATES	150

FloFab reserves the right to change specifications without prior notification.

We are proud supplier for the following completed and on going projects :



**Rutgers University
Apartments**
604 Bartholomew Road
Piscataway, NJ 08854



Bella Vista Ltd.,
26 Torbay Road. St.
John's, NL. A2A 2G4



Cité du Nouveau Monde
64 rue St-Paul Ouest,
Montreal, QC, H2Y 1Y8



Le Murray
1169, Rue Ottawa,
Montréal, QC H3C 1S6

Sales and Service:

Quebec, Canada
Tel. : (450) 621-2995
Fax : (450) 621-4995

Lake Worth
Florida, USA
33467-5749

Toronto, Canada
Tel. : +1 (647) 544-2995

www.flofab.com

SERVICE 24/7 : parts@flofab.com

