

W2222X

U-TUBE HEAT EXCHANGERS

2 Pass Water To Liquid – 22" Shell Diameter

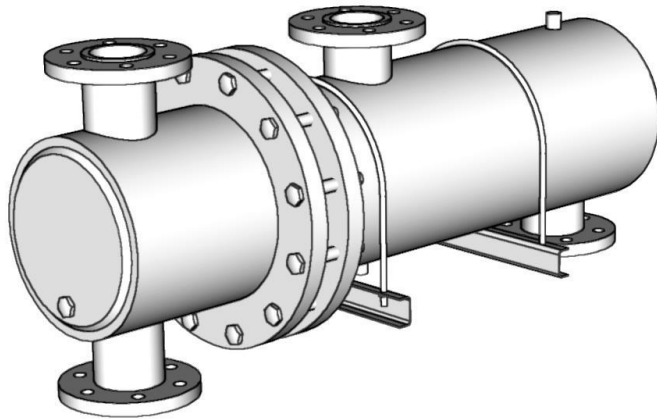

Saddle Dimensions

Unit Size				
Shell (Nom.)	H	W	X	HD
22"	17	25	18	7/8

Port Designations

N1	N2	K1	K2
Inlet	Outlet	Outlet	Inlet
Hot Water	Hot Water	Cold Water	Cold Water

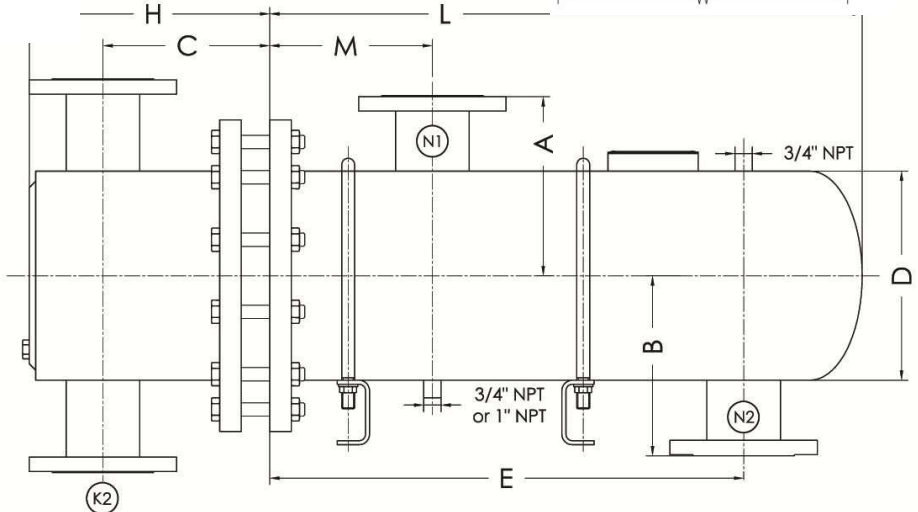
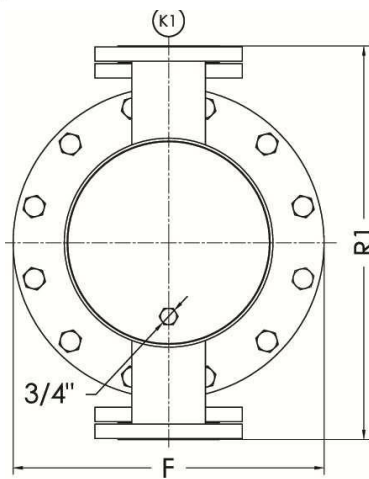
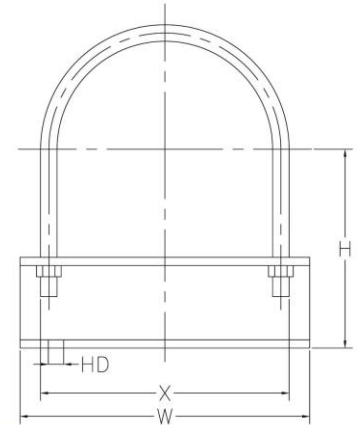

Dimensions are in Inches

Model	R1	K1/K2	C	H	D	F	M	E	B	A	L	N1	N2	HTA (sqft)	Est. Ship. Weight(Lbs)
W222221	35	10" Flange	17	24 1/2	22	29 1/2	14	25 3/8	17	17	38 3/8	12" Flange	12" Flange	193.5	1596
W222222	35	10" Flange	17	24 1/2	22	29 1/2	14	37 3/8	17	17	50 3/8	12" Flange	12" Flange	265	1780
W222223	35	10" Flange	17	24 1/2	22	29 1/2	14	49 3/8	17	17	62 3/8	12" Flange	12" Flange	336.5	1964
W222224	35	10" Flange	17	24 1/2	22	29 1/2	14	61 3/8	17	17	74 3/8	12" Flange	12" Flange	408	2148
W222225	35	10" Flange	17	24 1/2	22	29 1/2	14	73 3/8	17	17	86 3/8	12" Flange	12" Flange	479.5	2332
W222226	35	10" Flange	17	24 1/2	22	29 1/2	14	85 3/8	17	17	98 3/8	12" Flange	12" Flange	551	2516
W222227	35	10" Flange	17	24 1/2	22	29 1/2	15	97 3/8	18	18	110 3/8	14" Flange	14" Flange	622.5	2700
W222228	35	10" Flange	17	24 1/2	22	29 1/2	15	109 3/8	18	18	122 3/8	14" Flange	14" Flange	694	2884

Materials Of Construction

	Standard	Optional
Shell	Steel	Stainless Steel (304/316)
Tubes	Stainless Steel (304)	Copper, SS 316, 90/10 CuNi
Tubesheet	Steel	Stainless Steel (304/316)
Connections	Steel	Stainless Steel (304/316)
Head	Cast Iron/Steel	Stainless Steel (304/316)
Gaskets	Non-asbestos, pressed fiber	

Design Parameters

	Standard		Optional	
	Design Pressure (PSI)	Design Temperature (F)	Design Pressure (PSI)	Design Temperature (F)
Shell	150	375	300	421
Tubes	150	375	400	448

- Not certified drawings. Dimensions subject to change without notice.