

W30230X

U-TUBE HEAT EXCHANGERS

2 Pass Water To Liquid – 30" Shell Diameter

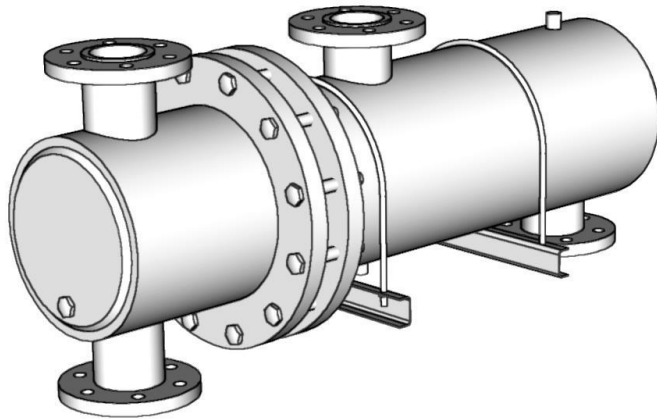

Saddle Dimensions

Unit Size				
Shell (Nom.)	H	W	X	HD
30"	21	33	22	7/8

Port Designations

N1	N2	K1	K2
Inlet	Outlet	Outlet	Inlet
Hot Water	Hot Water	Cold Water	Cold Water

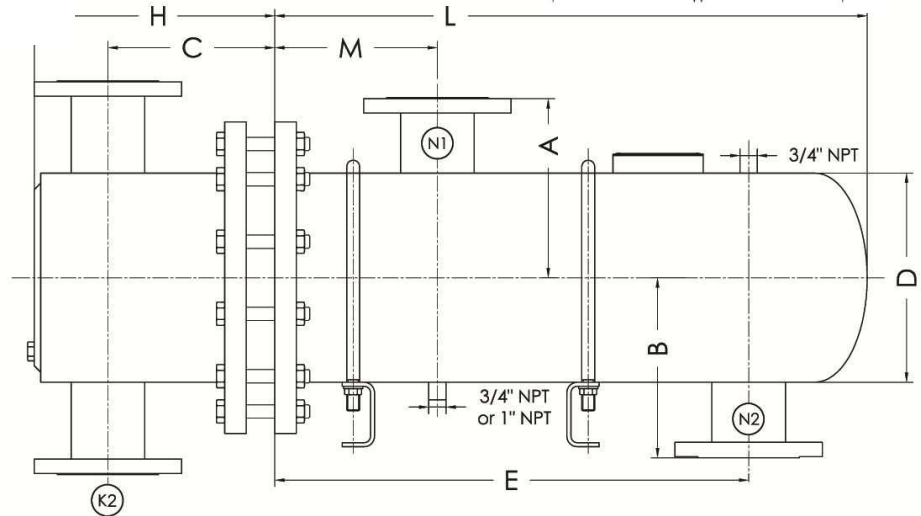
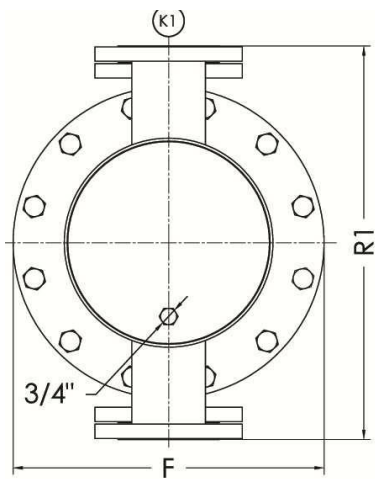
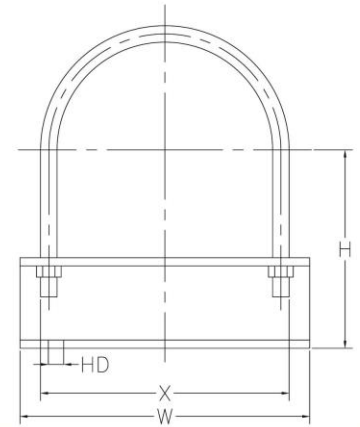

Dimensions are in Inches

Model	R1	K1/K2	C	H	D	F	M	E	B	A	L	N1	N2	HTA (sqft)	Est. Ship. Weight(Lbs)
W302301	42	14" Flange	19 5/8	28 7/8	30	38 3/4	16	23	22	22	38 1/2	16" Flange	16" Flange	377.6	3405
W302302	42	14" Flange	19 5/8	28 7/8	30	38 3/4	16	35	22	22	50 1/2	16" Flange	16" Flange	520.5	3724
W302303	42	14" Flange	19 5/8	28 7/8	30	38 3/4	16	47	22	22	62 1/2	16" Flange	16" Flange	663.4	4043
W302304	42	14" Flange	19 5/8	28 7/8	30	38 3/4	16	59	22	22	74 1/2	16" Flange	16" Flange	806.3	4362
W302305	42	14" Flange	19 5/8	28 7/8	30	38 3/4	16	71	22	22	86 1/2	16" Flange	16" Flange	949.2	4681
W302306	42	14" Flange	19 5/8	28 7/8	30	38 3/4	16	83	22	22	98 1/2	16" Flange	16" Flange	1092	5000
W302307	42	14" Flange	19 5/8	28 7/8	30	38 3/4	17	95	22	22	110 1/2	18" Flange	18" Flange	1235	5319
W302308	42	14" Flange	19 5/8	28 7/8	30	38 3/4	17	107	22	22	122 1/2	18" Flange	18" Flange	1378	5638

Materials Of Construction

	Standard	Optional
Shell	Steel	Stainless Steel (304/316)
Tubes	Stainless Steel (304)	Copper, SS 316, 90/10 CuNi
Tubesheet	Steel	Stainless Steel (304/316)
Connections	Steel	Stainless Steel (304/316)
Head	Cast Iron/Steel	Stainless Steel (304/316)
Gaskets	Non-asbestos, pressed fiber	

Design Parameters

	Standard		Optional	
	Design Pressure (PSI)	Design Temperature (F)	Design Pressure (PSI)	Design Temperature (F)
Shell	150	375	300	421
Tubes	150	375	400	448

- Not certified drawings. Dimensions subject to change without notice.