

W08408X

U-TUBE HEAT EXCHANGERS

4 Pass Water to Liquid – 8" Shell Diameter

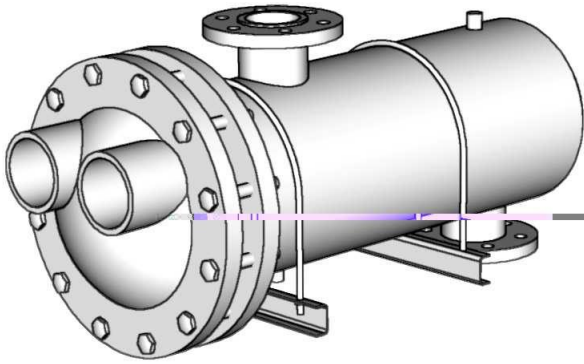

Saddle Dimensions

Unit Size				
Shell (Nom.)	H	W	X	HD
8"	7 5/16	11 1/4	9	5/8

Port Designations			
N1	N2	K1	K2
Inlet	Outlet	Outlet	Inlet
Hot Water	Hot Water	Cold Water	Cold Water

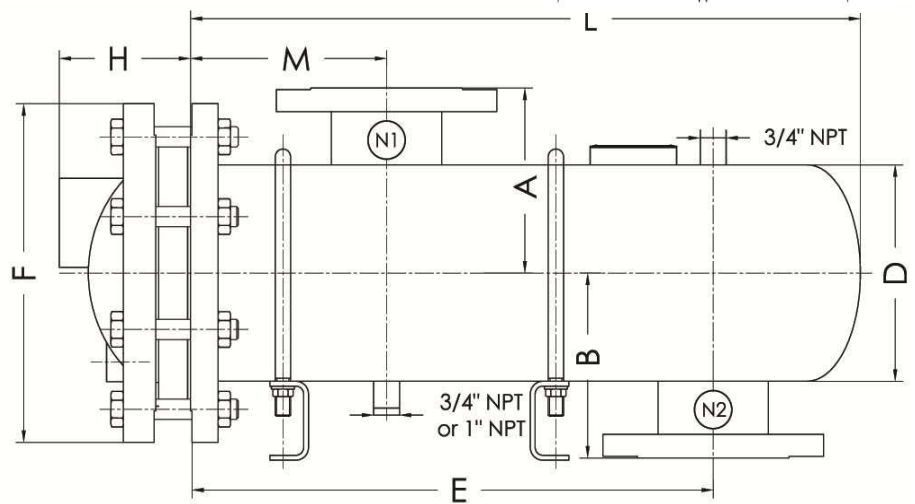
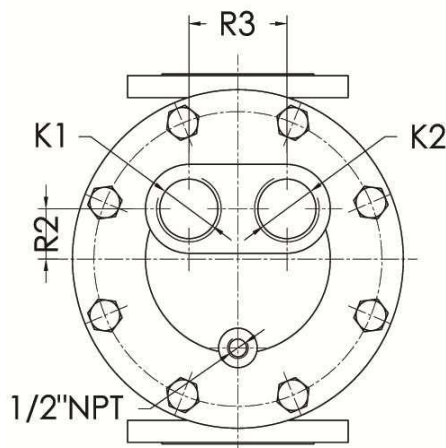
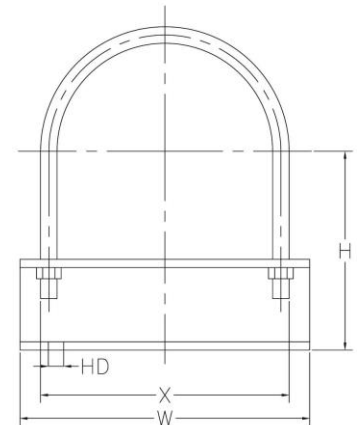

Dimensions are in Inches

Model	R2	R3	K1/K2 (FNPT)	H	D	F	M	E	B	A	L	N1	N2	HTA (sqft)	Est. Ship. Weight(Lbs)
W084081	2	4	2	4 1/4	8 5/8	13 1/2	8	18	7 3/8	7 3/8	24	4" Flange	4" Flange	14.7	241
W084082	2	4	2	4 1/4	8 5/8	13 1/2	8	30	7 3/8	7 3/8	36	4" Flange	4" Flange	22.7	308
W084083	2	4	2	4 1/4	8 5/8	13 1/2	8	42	7 3/8	7 3/8	48	4" Flange	4" Flange	30.7	371
W084084	2	4	2	4 1/4	8 5/8	13 1/2	8	54	7 3/8	7 3/8	60	4" Flange	4" Flange	38.7	441
W084085	2	4	2	4 1/4	8 5/8	13 1/2	8	66	7 3/8	7 3/8	72	4" Flange	4" Flange	46.6	505
W084086	2	4	2	4 1/4	8 5/8	13 1/2	8	78	7 3/8	7 3/8	84	4" Flange	4" Flange	54.6	571
W084087	2	4	2	4 1/4	8 5/8	13 1/2	8	90	7 3/8	7 3/8	96	4" Flange	4" Flange	62.6	638
W084088	2	4	2	4 1/4	8 5/8	13 1/2	8	102	7 3/8	7 3/8	108	4" Flange	4" Flange	70.6	701
W084089	2	4	2	4 1/4	8 5/8	13 1/2	8	114	7 3/8	7 3/8	120	4" Flange	4" Flange	78.6	768

Materials Of Construction

	Standard	Optional
Shell	Steel	Stainless Steel (304/316)
Tubes	Stainless Steel (304)	Copper, SS 316, 90/10 CuNi
Tubesheet	Steel	Stainless Steel (304/316)
Connections	Steel	Stainless Steel (304/316)
Head	Cast Iron/Steel	Stainless Steel (304/316)
Gaskets	Non-asbestos, pressed fiber	

Design Parameters

	Standard		Optional	
	Design Pressure (PSI)	Design Temperature (F)	Design Pressure (PSI)	Design Temperature (F)
Shell	150	375	300	421
Tubes	150	375	400	448

- Not certified drawings. Dimensions subject to change without notice.