

W12412X

U-TUBE HEAT EXCHANGERS

4 Pass Water To Liquid – 12” Shell Diameter

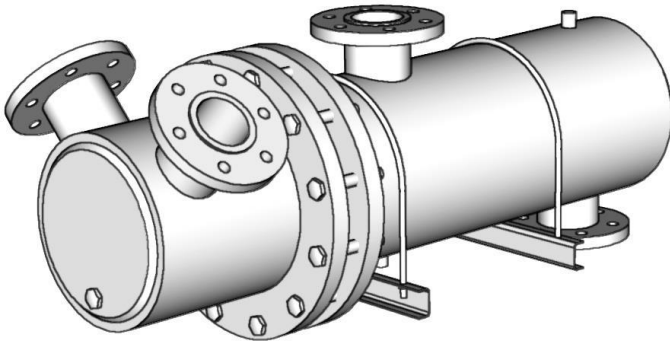

Saddle Dimensions

Unit Size				
Shell (Nom.)	H	W	X	HD
12"	9 3/8	15 5/8	11	3/4

Port Designations			
N1	N2	K1	K2
Inlet	Outlet	Outlet	Inlet
Hot Water	Hot Water	Cold Water	Cold Water

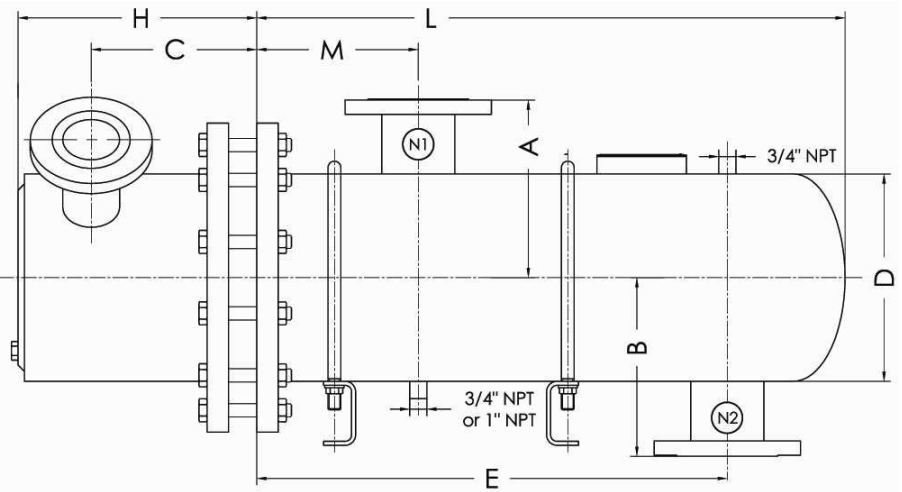
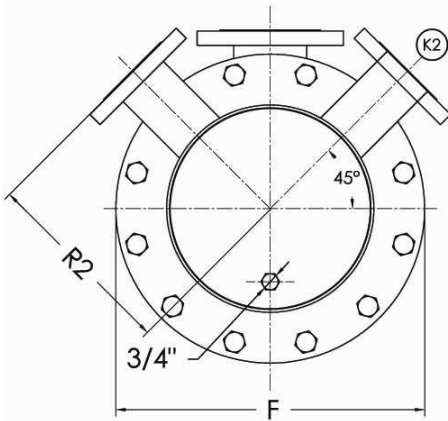
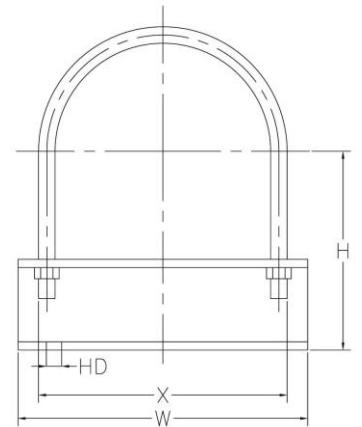

Dimensions are in Inches

Model	R2	K1/K2	C	H	D	F	M	E	B	A	L	N1	N2	HTA (sqft)	Est. Ship. Weight(Lbs)
W124121	12	3" Flange	10 1/8	14 5/8	12 3/4	19	10	29	11	11	36 1/4	4" Flange	4" Flange	58.6	710
W124122	12	3" Flange	10 1/8	14 5/8	12 3/4	19	10	41	11	11	48 1/4	6" Flange	6" Flange	79	796
W124123	12	3" Flange	10 1/8	14 5/8	12 3/4	19	10	53	11	11	60 1/4	6" Flange	6" Flange	99.5	881
W124124	12	3" Flange	10 1/8	14 5/8	12 3/4	19	10	65	11	11	72 1/4	6" Flange	6" Flange	119.9	972
W124125	12	3" Flange	10 1/8	14 5/8	12 3/4	19	10	77	11	11	84 1/4	8" Flange	8" Flange	140.3	1057
W124126	12	3" Flange	10 1/8	14 5/8	12 3/4	19	10	88	11	11	96 1/4	8" Flange	8" Flange	160.8	1141
W124127	12	3" Flange	10 1/8	14 5/8	12 3/4	19	10	100	11	11	108 1/4	8" Flange	8" Flange	181.2	1227
W124128	12	3" Flange	10 1/8	14 5/8	12 3/4	19	10	112	11	11	120 1/4	8" Flange	8" Flange	201.6	1311

Materials Of Construction

	Standard	Optional
Shell	Steel	Stainless Steel (304/316)
Tubes	Stainless Steel (304)	Copper, SS 316, 90/10 CuNi
Tubesheet	Steel	Stainless Steel (304/316)
Connections	Steel	Stainless Steel (304/316)
Head	Cast Iron/Steel	Stainless Steel (304/316)
Gaskets	Non-asbestos, pressed fiber	

Design Parameters

	Standard		Optional	
	Design Pressure (PSI)	Design Temperature (F)	Design Pressure (PSI)	Design Temperature (F)
Shell	150	375	300	421
Tubes	150	375	400	448

- Not certified drawings. Dimensions subject to change without notice.