

W16416X

U-TUBE HEAT EXCHANGERS

4 Pass Water To Liquid – 16" Shell Diameter

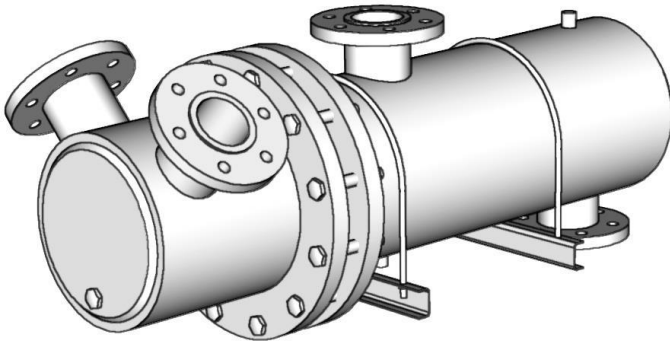

Saddle Dimensions

Unit Size	H	W	X	HD
16"	12	19	13	3/4

Port Designations

N1	N2	K1	K2
Inlet	Outlet	Outlet	Inlet
Hot Water	Hot Water	Cold Water	Cold Water

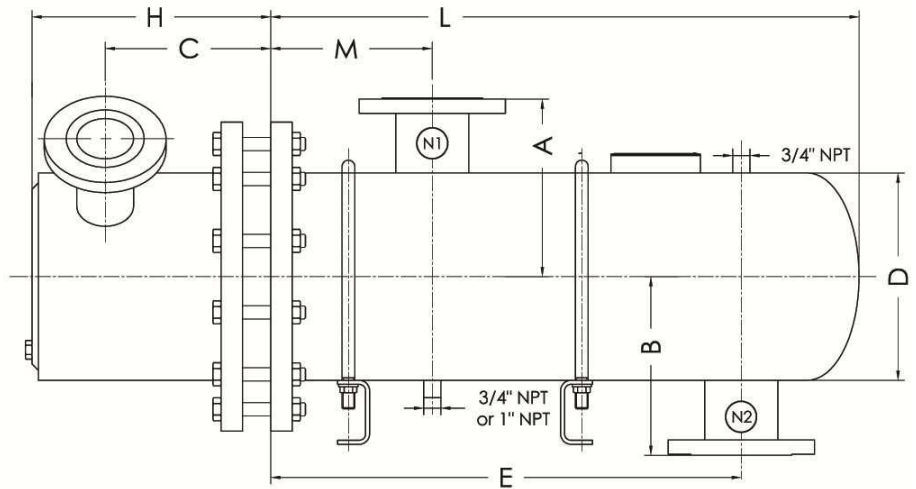
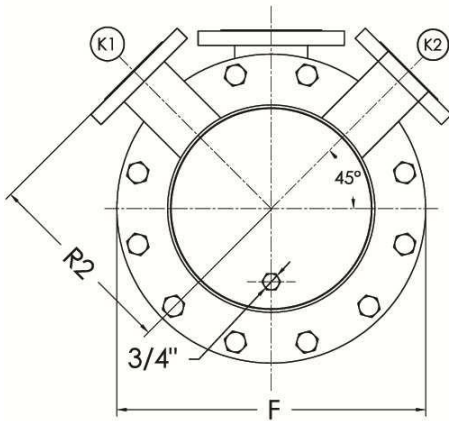
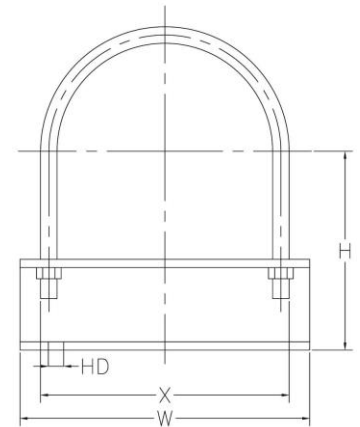

Dimensions are in Inches

Model	R2	K1/K2	C	H	D	F	M	E	B	A	L	N1	N2	HTA (sqft)	Est. Ship. Weight(Lbs)
W164161	14 1/4	4" Flange	12 1/8	17 3/8	16	23 1/2	11	28 1/2	13	13	37	6" Flange	6" Flange	104.5	945
W164162	14 1/4	4" Flange	12 1/8	17 3/8	16	23 1/2	11	40	13	13	49	6" Flange	6" Flange	141.4	1063
W164163	14 1/4	4" Flange	12 1/8	17 3/8	16	23 1/2	11	52	13	13	61	8" Flange	8" Flange	178.4	1181
W164164	14 1/4	4" Flange	12 1/8	17 3/8	16	23 1/2	11	64	13	13	73	8" Flange	8" Flange	215.3	1305
W164165	14 1/4	4" Flange	12 1/8	17 3/8	16	23 1/2	11	76	13	13	85	10" Flange	10" Flange	252.2	1387
W164166	14 1/4	4" Flange	12 1/8	17 3/8	16	23 1/2	11	87 1/2	13	13	97	10" Flange	10" Flange	289.1	1505
W164167	14 1/4	4" Flange	12 1/8	17 3/8	16	23 1/2	11	99 1/2	13	13	109	10" Flange	10" Flange	326	1624
W164168	14 1/4	4" Flange	12 1/8	17 3/8	16	23 1/2	11	111 1/2	13	13	121	10" Flange	10" Flange	363	1741

Materials Of Construction

	Standard	Optional
Shell	Steel	Stainless Steel (304/316)
Tubes	Stainless Steel (304)	Copper, SS 316, 90/10 CuNi
Tubesheet	Steel	Stainless Steel (304/316)
Connections	Steel	Stainless Steel (304/316)
Head	Cast Iron/Steel	Stainless Steel (304/316)
Gaskets	Non-asbestos, pressed fiber	

Design Parameters

	Standard		Optional	
	Design Pressure (PSI)	Design Temperature (F)	Design Pressure (PSI)	Design Temperature (F)
Shell	150	375	300	421
Tubes	150	375	400	448

- Not certified drawings. Dimensions subject to change without notice.