

W26426X

U-TUBE HEAT EXCHANGERS

4 Pass Water To Liquid – 26" Shell Diameter

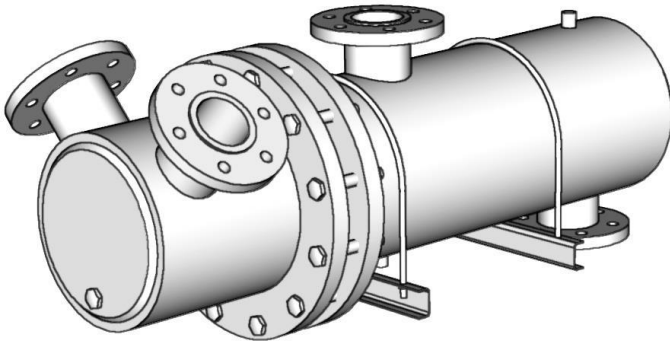

Saddle Dimensions

Unit Size				
Shell (Nom.)	H	W	X	HD
26"	19	30	20	7/8

Port Designations

N1	N2	K1	K2
Inlet	Outlet	Outlet	Inlet
Hot Water	Hot Water	Cold Water	Cold Water

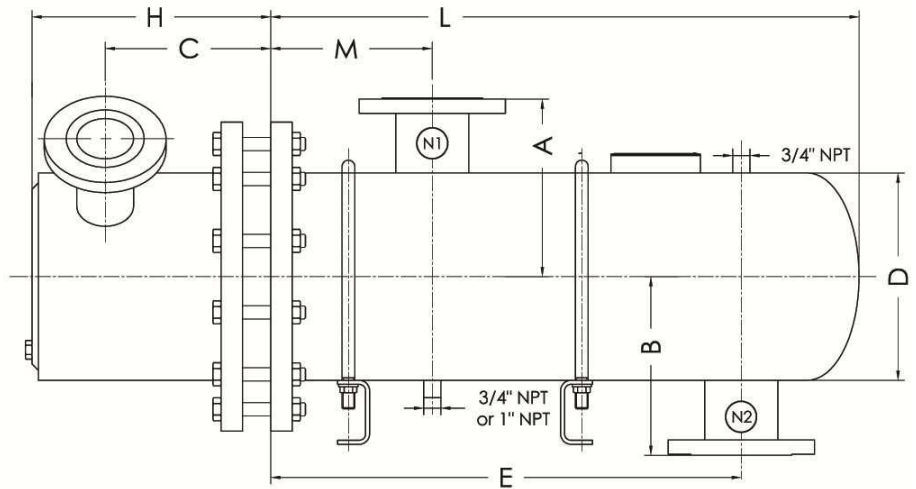
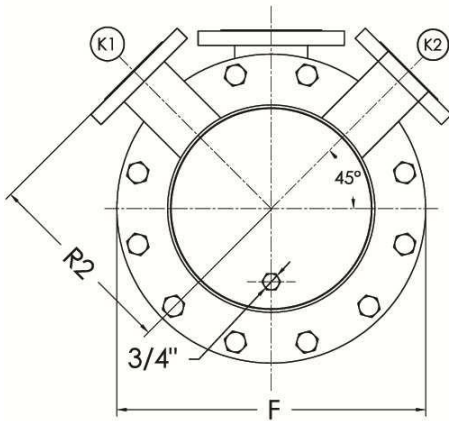
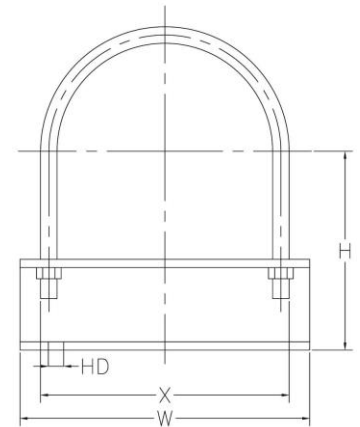

Dimensions are in Inches

Model	R2	K1/K2	C	H	D	F	M	E	B	A	L	N1	N2	HTA (sqft)	Est. Ship. Weight(Lbs)
W264261	18 1/4	8" Flange	17	24 3/4	26	34 1/4	15	23 3/4	20	20	36	14" Flange	14" Flange	288.6	2236
W264262	18 1/4	8" Flange	17	24 3/4	26	34 1/4	15	35 3/4	20	20	48	14" Flange	14" Flange	393.4	2480
W264263	18 1/4	8" Flange	17	24 3/4	26	34 1/4	15	47 3/4	20	20	60	14" Flange	14" Flange	500.2	2724
W264264	18 1/4	8" Flange	17	24 3/4	26	34 1/4	15	59 3/4	20	20	72	14" Flange	14" Flange	607	2968
W264265	18 1/4	8" Flange	17	24 3/4	26	34 1/4	15	71 3/4	20	20	84	14" Flange	14" Flange	713.8	3212
W264266	18 1/4	8" Flange	17	24 3/4	26	34 1/4	15	83 3/4	20	20	96	14" Flange	14" Flange	820.6	3456
W264267	18 1/4	8" Flange	17	24 3/4	26	34 1/4	16	95 3/4	21	21	108	16" Flange	16" Flange	927.4	3700
W264268	18 1/4	8" Flange	17	24 3/4	26	34 1/4	16	107 3/4	21	21	120	16" Flange	16" Flange	1034.4	3944

Materials Of Construction

	Standard	Optional
Shell	Steel	Stainless Steel (304/316)
Tubes	Stainless Steel (304)	Copper, SS 316, 90/10 CuNi
Tubesheet	Steel	Stainless Steel (304/316)
Connections	Steel	Stainless Steel (304/316)
Head	Cast Iron/Steel	Stainless Steel (304/316)
Gaskets	Non-asbestos, pressed fiber	

Design Parameters

	Standard		Optional	
	Design Pressure (PSI)	Design Temperature (F)	Design Pressure (PSI)	Design Temperature (F)
Shell	150	375	300	421
Tubes	150	375	400	448

- Not certified drawings. Dimensions subject to change without notice.