



Centrifugal Pumps

Series 1000

Operation, Maintenance
& Installation Manual



www.flofab.com

001-iom-2017-1000

CAUTION!!

DO NOT RUN PUMP DRY, SEAL DAMAGE MAY OCCUR. INSPECT PUMP SEAL REGULARLY FOR LEAKS, REPLACE AS REQUIRED.

FOR LUBRICATION REQUIREMENTS, CONSULT SERVICE INSTRUCTIONS. FAILURE TO FOLLOW INSTRUCTIONS COULD RESULT IN INJURY OR PROPERTY DAMAGE. COUPLER ALIGNMENT IS REQUIRED! LEVEL AND GROUT PUMP BEFORE USE!

CHECK ALIGNMENT BEFORE GROUTING, AFTER SYSTEM 18 FILLED, AFTER SERVICING PUMP, AND AS REQUIRED.

CONSULT THE SERVICE INSTRUCTIONS FOR DETAILS. FAILURE TO FOLLOW THESE

INSTRUCTIONS COULD RESULT IN INJURY OR PROPERTY DAMAGE. FAILURE TO FOLLOW THIS INSTRUCTION MAY VOID THE WARRANTY OF THE UNIT.

MOUNTING INSTRUCTIONS

INSTALLATION

This pump is built to provide years of service if installed properly and attached to a suitable foundation. A base of concrete weighing 2 1/2 times the weight of the pump is recommended. (Check the shipping ticket for pump weight).

If possible, tie the concrete pod in with the finished floor.

To facilitate easy servicing, some type of expansion fitting should be utilized. The female portion should be inserted into a suitable hole in the pod so that its top surface is flush with the pod surface. Thus, when the hold-down bolts are removed, the motor can be removed by sliding it back from the pump. (See figure 6).

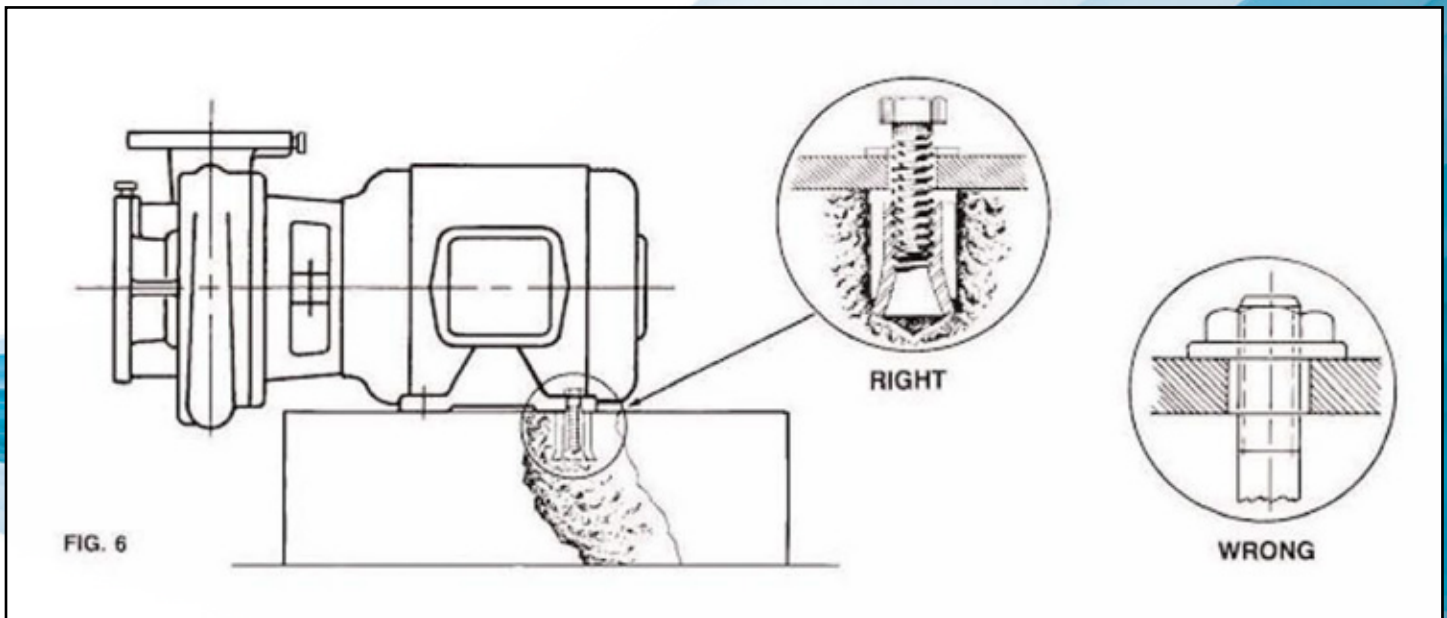

INSTALLATION

LOCATION OF UNIT

1. Locate the pump in a dry place as near the liquid source as practical with a short, direct suction pipe and a minimum number of elbows and fittings on the discharge line.
2. Place the unit so that it will be accessible for inspection during operation and maintenance.

FOUNDATION

1. Foundation should be sufficiently substantial to absorb any vibration and to form a permanent rigid support for the base plate. This is important in maintaining alignment of a direct connected unit.
2. Foundation bolts of suitable size should be embedded in the concrete, located by a drawing or template of the pump baseplate.
3. Pipe sleeves about two and on-half diameter larger than the bolts should be used to allow movement. For final positioning of the bolts.

GROUTING

1. Place pumping unit on foundation with wedges under base plate, leaving approximately 3/4" space for grouting
2. Carefully level the unit by adjusting the wedges (see FIGURE I) until shafts of pump and driver are levelled.

3. Check coupling faces as well as suction and discharge flanges of pump for horizontal or vertical position by means of a level. Slight misalignment at this point may be corrected by adjusting the wedges.
4. Build a dam around base plate at least 2-1/2" high (see FIGURE II).
5. Mix the grout, using 1 part pure Portland cement and 2 parts building sand to avoid excessive shrinkage. This mix should require no more than 6 gallons of water per bag of cement. Let the mixture stand for several hours, remixing thoroughly before use without adding water.
6. Before grouting, surface of the rough concrete must be well saturated with water.
7. Pour sufficient grout to fill entire space under base, using a rod through the grout hole to release any air pockets

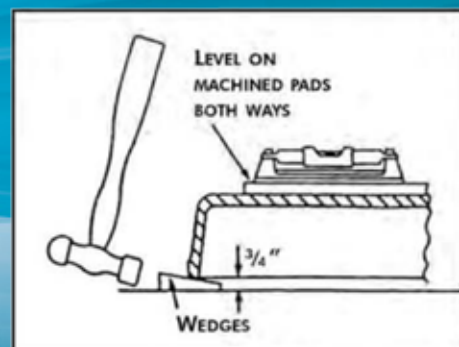

FIGURE I

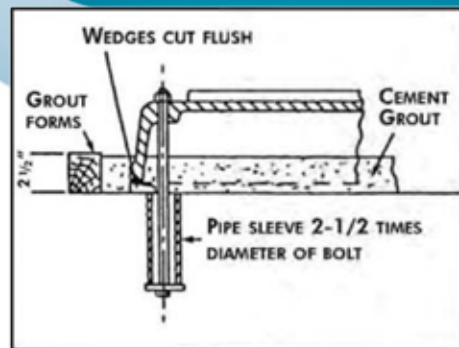

FIGURE II



8. To prevent cracking, protect grout against rapid drying by covering exposed surfaces with wet burlap for 2 days.
9. Let grout harden For several days
10. Tighten anchor bolts and recheck alignment. Any misalignment, now and after pipe joints are made, must be corrected by placing shims between base and driver or pump feet.

PIPING (GENERAL)

1. Never connect a pump to piping. Always start piping from pump (except In-Line Pumps).
2. Use as Few bends as possible and preferably log radius ones.
3. Install good supports under suction and discharge piping with anchors near but independent of the pump. Make sure piping exerts no strain on pump as this would throw the unit out of alignment or distort the casing.
4. Increase the size of both suction and discharge pipes at pump nozzle to suit pump capacity and particular conditions of installation.
5. Layout the suction line with a continual rise towards the pump without high points, thus eliminating possibility of air pockets.
6. Test suction line for air leaks before starting. This becomes essential with long suction line or high static lift.
7. Install, at pump suction, a straight pipe of a length equivalent to 4 or 5 times its diameter. This becomes essential when handling hot liquids, 1 20°F and above.
8. Install gate valve close to pump in both suction and discharge lines on Aooded suction application. This is used mainly to isolate the pump for inspection or repair.
9. Install a check valve in discharge line between pump and gate valve to protect pump from excessive pressure and to prevent water running back through the pump in case of driver failure.
10. Install a foot valve at bottom of the suction pipe to Facilitate priming of pump for operation under suction lift. A small by-pass line around the discharge check valve will compensate for foot valve leaks.
11. Install a suction strainer to protect pump against foreign matter in initial start-up as well as in normal operafon. Size liberally.
12. Install pressure gauges on both sides of strainer to indicate pressure drop through the strainer. Stop pump and clean the strainer when pressure drop starts to climb.
13. Install vent valve at high point of pump casing to vent casing and suction piping of air and vapor before start-up. This valve is also used during priming of pump or later if pump becomes air or vapor bound.
14. Connect a compound gauge to the pump suction and a pressure gauge to the discharge. This ensures close check on pump performance.
15. Connect drain pipe to drain pump base.

CAUTION

- A. DISCHARGE VALVE MUST ONLY BE USED TO REDUCE THE FLOW OR SHUT-OFF THE PUMP.
- B. CARE MUST BE TAKEN IN THE SUCTION LINE LAYOUT AND INSTALLATION , AS IT IS USUALLY THE MAJOR SOURCE OF TROUBLE ON CENTRIFUGAL PUMP OPERATION.

ALIGNMENT

Purpose of the flexible coupling is to compensate for temperature changes and to permit end movement of shafts without interfering with each other. It will not compensate for misalignment. Alignment should be checked as follows:

1. Place a straight edge across the coupling as shown in FIGURE III. This must rest evenly on both rims at top, bottom and both sides.
2. With a pair of inside calipers or thickness gouge, check distance between coupling halves at points where straight edge was used. Distance must be equal at all points

CAUTION

- A. FOR PUMPS DRIVEN BY STEAM TURBINE OR HANDLING HOT LIQUIDS, ALIGNMENT SHOULD BE CHECKED AT OPERATING TEMPERATURE.
- B. FLEXIBLE SHAFTS CAN ABSORB MOMENTARY ANGULAR MISALIGNMENT OF 15 TO 22 DEGREES DEPENDING UPON SIZE. PUMPS EQUIPPED WITH FLEXIBLE SHAFT DO NOT REQUIRE ANY SPECIAL ATTENTION AT TIME OF INSTALLATION. ALIGNMENT ON SITE IS NOT NECESSARY UNLESS BASE PLATE IS WARPED OUT OF PROPORTION.
- C. FAULTY ALIGNMENT WILL RESULT IN NOISY PUMP OPERATION, REDUCED BEARING LIFE, EXCESSIVE COUPLING WEAR AND WASTE OF POWER. IT IS THEREFORE ESSENTIAL:
 1. TO CHECK THE ALIGNMENT CAREFULLY AFTER THE FOUNDATION BOLTS HAVE BEEN PROPERLY THIGHTENED.
 2. TO CHECK AGAIN THE ALIGNMENT AFTER PIPING IS INSTALLED AND UNIT HAS OPERATED UNDER NORMAL CONDITIONS AT OPERATING TEMPERATURE.

FIGURE III

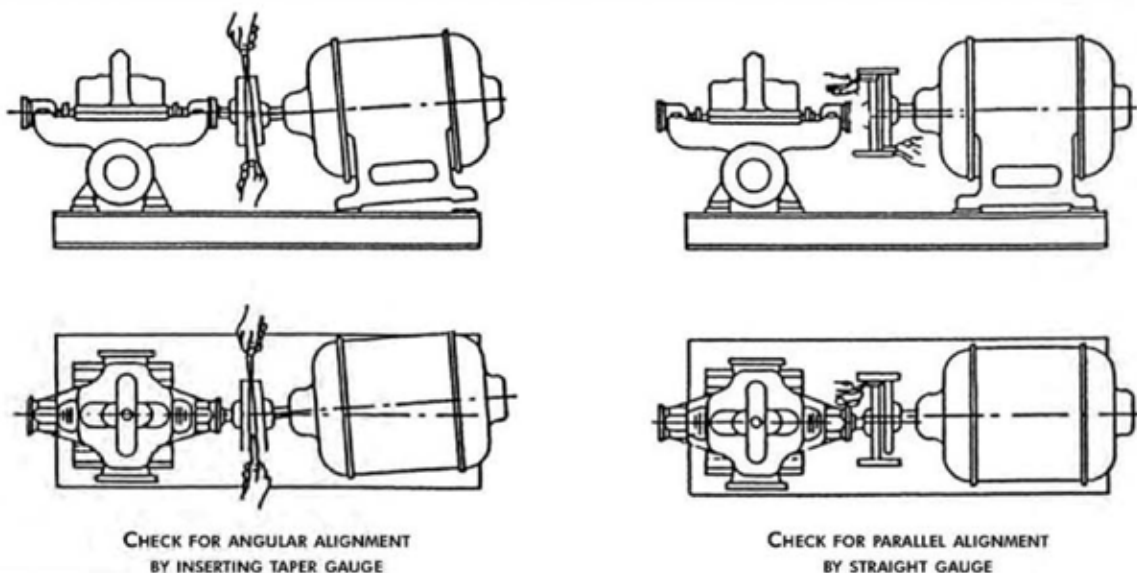



OPERATION

STARTING OF ELECTRIC MOTOR DRIVEN PUMPS

1. Before connecting motor and starter to the line:
 - 1.1. Check wiring information available inside the conduit box.
 - 1.2. Check voltage and frequency of power supply with what s shown on motor nameplate.
 - 1.3. Check current rating of overload relays and fuses against nameplate full load current value.
2. Check lubrication and pocking (see MAINTENANCE}.
3. Check if rotor is free to turn. It must be possible to revolve the rotor by hand. If the rotor drags even slightly, do not operate until the cause of trouble is located and corrected.
4. For unit with fluid drive, refer to the maintenance instructions of Auid drives.
5. If unit is for high temperature application, refer to operating instructions For high temperature pumps.
6. Prime the pump. A pump is primed when cosing and suction line are filled with liquid and when all the air contained in the pump has been allowed to escape. If pump is to operate under suction lift without foot valve, priming is done by pumping air out by means of an ejector, on exhauster or a vacuum pump.
7. Check direction of driver rotation. Proper direction is indicated by arrow on pump ca sing.
8. Check electric motor current as soon as motor is started to verify whether or not the mechanical load applied corresponds to the motor rating. The continuous full load current value should be within the electric motor nameplate rating with service factor taken into account.

CAUTION

- A. MAKE SURE THE GATE VALVE ON PUMP SUCTION IS FULLY OPEN AS THROTILING ON SUCTION SIDE IS HARMFUL TO THE PUMP.
- B. MAKE SURE PUMP WILL NOT RUN DRY. MOST CENTRIFUGAL PUMPS HAVE CLOSE CLEARANCES AND CANNOT RUN DRY WITHOUT SERIOUS DAMAGE RESULTING.



MAINTENANCE

A systematic inspection made at regular intervals, giving special attention to the following, will ensure years of trouble-free operation.

GENERAL CARE

1. Keep unit clean.
2. Avoid excessive belt tension.
3. Provide the motor with adequate overload protection.
4. Keep flying chips or other loose particles away from the ventilating openings of the motor.
5. Avoid operating the unit in overheated surroundings.
6. Guard three phase motor against single phasing which is frequently accompanied by an unusual humming sound, a drop in speed, and by excessive heating which, if continued, may burn out the motor windings.
7. Use thermometers when checking temperatures.
8. If pump is standing idle in freezing weather, pump casing and piping should be drained.

BEARINGS

1. LIFE LUBRICATED BEARINGS are heavy duty permanently lubricated, sealed type and require no maintenance
2. GREASE LUBRICATED BEARINGS require very little attention. More trouble can be caused by overcharging than by undercharging with grease. Approximately every month, depending on service, inject a small quantity of grease (Esso Andok No. 280 or equal} into bearing container after removing the grease outlet plug so that old grease is flushed out and bearing is not over-filled.



MECHANICAL SHAFT SEAL LIMITATIONS

Standard FLO FAS pumps are equipped with mechanical seals. Standard mechanical seals have Ni-resist seat, carbon washer and Viton below. Maximum recommended operating temperatures and pressures are shown below.

MOTOR HP & SPEED	SUCTION PRESSURE (PSIG)	MAXIMUM TEMPERATURE (°F)
Up to 10HP 1750 RPM	60	250
	85	225
	125	160
15 - 50HP 1750 RPM	50	250
	60	225
	100	160
Up to 15HP 3500 RPM	20	180
	125	120
20 - 60HP 3500 RPM	15	180
	115	120

CAUTION

- A. A MECHANICAL SEAL IS A PRECISION PRODUCT. HANDLE IT WITH CARE. SPECIAL CARE MUST BE TAKEN WITH THE SEALING WASHER AND SEAT. DO NOT LET THEM DROP AND TAKE PARTICULAR CARE NOT TO SCRATCH THE LAPPED FACES.
- B. NEVER RUN SEALS DRY.
- C. FOLLOW SEAL MANUFACTURER'S INSTRUCTIONS.



PREVENTIVE MAINTENANCE

- 1 . Protect pump with a suitable strainer
2. Never pump a liquid for which the pump was not designed (check with your FLO FAS representative).
3. Keep the right amount of the right lubricant in bearings at all times, Following lubrication instructions.
4. Check periodically pump and motor alignment.
5. Any down sloping towards the pump in suction piping should be corrected.
6. See that piping puts no strain on pump casing.
7. Never allow pump to run dry.
8. Examine wearing rings at regular intervals.
9. If shaft sleeves are badly scored, replace them immediately.
10. If the liquid being pumped contains grit, o separate source of sealing liquid should be used.
11. A routine maintenance schedule should be set-up to ensure an optimum inspection and service operation in order to get the best service out of your pumping equipment.

VERTICAL IN -LINE PUMP MAINTENANCE AND SERVICE

Type V, VL, RI, SC pumps are built to operate without periodic maintenance with the exception of lubrication motor bearings with silicone grease such as Dow-Corning 44, Keystone #78 or Supermill ASU 06752 grease every 3 months. Good operational life will depend upon proper pump selection, installation and continuous wafer lubrication of the mechanical seals. The air vent plug must always be loosened to thoroughly vent casing before start-up and fo insure water lubrication of mechanical seals.

Impurities in the system will shorten the operational life of mechanical seals due to the generally abrasive charaderistics of these impurities. Most common is black iron oxide which is highly magnetic and has a tendency to form hard coating on all surfaces in contact with water. Water treatment is also an important factor in seal life. It is recommended that the chromate content in water be limited to 250 ppm.



RENEWAL PARTS

The service for which centrifugal pump is used will determine, to a great extent, the minimum number of spare parts that should be carried in stock at the installation site. The minimum for any centrifugal pump should include:

- One set of wearing rings
- One set of shaft sleeves (or a shaft if no sleeves are used)
- One set of bearings
- Sufficient stock of spare mechanical seal
- Material For gasket

When ordering spare or repair parts, always give pump serial number and full description of part(s) required.

WARRANTY

FLO FAB pumps are guaranteed against defective workmanship and material for a period of twelve months from date of shipment from Manufacturing Plant. Should the pump fail within this warranty period, our responsibility is limited to the repair or replacement of defective parts, provided such are returned to our Plant, transportation prepaid. We do not accept liability for damage or break-down from causes beyond our control, or the result of reasonable wear nor for repair made, or attempted to be made without prior sanction, nor for any consequential damage resulting from the failure of a pump. The customer will assume all labour charges incurred in making the replacement or adjustment of the parts

PLEASE NOTE THAT THERE IS **NO GUARANTEE** ON MECHANICAL SHAFT SEALS.

TROUBLE CHART (SEE KEY IN THE NEXT PAGE)

SYMPTOMS	POSSIBLE CAUSES
Pump does not deliver water	1, 2, 3, 4, 6, 11, 14, 16, 17, 22, 23
Insufficient capacity delivered	2, 3, 4, 5, 6, 7, 8, 9, 10, 11, 14, 17, 20, 22, 23, 29, 30, 31
Insufficient pressure developed	5, 14, 16, 18, 19, 20, 23, 24, 26, 27, 29, 33, 34, 37
Pump loses prime after starting	2, 3, 5, 6, 7, 8, 11, 12, 13
Pump requires excessive power	15, 16, 18, 19, 20, 23, 24, 26, 27, 29, 33, 34, 37
Stuffing box leaks excessively	24, 26, 32, 33, 34, 35, 36, 38, 39, 40
Packing has short life	12, 13, 24, 26, 28, 32, 33, 34, 35, 36, 37, 38, 39, 40
Pump vibrates or is noisy	2, 3, 4, 9, 10, 11, 21, 23, 24, 25, 26, 27, 28, 30, 35, 36, 41, 42, 43, 44, 45, 46, 47
Bearings have short life	24, 26, 27, 28, 35, 36, 41, 42, 43, 44, 45, 46, 47
Pump overheats and seizes	1, 4, 21, 22, 24, 27, 28, 35, 36, 41

KEY

SUCTION TROUBLES

1. Pump not primed.
2. Pump or suction pipe not completely filled with liquid.
3. Suction lift too high.
4. Insufficient margin between suction pressure and vapor pressure (available NPSH too low).
5. Excessive amount of air or gas in liquid.
6. Air pocket in suction line,
7. Air leakage into suction line.
8. Air leakage into pump through stuffing boxes.
9. Foot valve too small.
10. Foot valve partially clogged.
11. Inlet of suction pipe insufficiently submerged,
12. Water seal pipe plugged.
13. Seal cage improperly located in stuffing box, preventing sealing fluid entering space to form the seal.

SYSTEM TROUBLES

14. Speed too low.
15. Speed too high.
16. Wrong direction of rotation.
17. Total head of system higher than pump design head.
18. Total head of system lower than pump design head.
19. Specific gravity of liquid different than design.
20. Viscosity of liquid differs from that for which designed.
21. Operation at very low capacity.

22. Parallel operation of pumps unsuitable for such operation.

MECHANICAL TROUBLES

23. Foreign matter in impeller.
24. Misalignment.
25. Foundation not rigid.
26. Shaft bent.
27. Rotating part rubbing on stationary part.
28. Bearing worn.
29. Wearing rings worn.
30. Impeller damaged.
31. Casing gasket defective, permitting internal leakage.
32. Shaft or shaft sleeves worn or scored at the packing.
33. Packing improperly installed.
34. Incorrect type of packing for operation conditions.
35. Shaft running off-center due to worn bearings or misalignment.
36. Rotor out of balance resulting in vibration.
37. Gland too tight, resulting in no Flow of liquid to packing.
38. Failure to provide cooling liquid to water-cooled stuffing boxes.
39. Excessive clearance at bottom of stuffing box between shaft and casing, causing packing to be forced into pump interior.

40. Dirt or grit in sealing liquid, leading to scoring of shaft or shaft sleeve.

41. Excessive thrust caused by a mechanical Failure inside the pump or by the failure of the hydraulic balancing device, if any.
42. Excessive amount of grease or oil in the housing of on antifriction bearing or lack of cooling, causing excessive bearing temperature.
43. Lack of lubrications.
44. Improper installation of antifriction bearings (damage during assembly).
45. Dirt getting into bearings.
46. Rusting of bearings due to water getting into housing.
47. Excessive cooling of water-cooled bearing resulting in condensation in the bearing housing of moisture from the atmosphere.

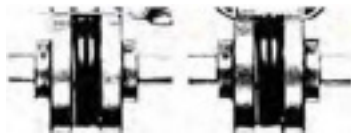

FLANGES ASSEMBLY

With a two-piece sleeve, do not move the wire ring to its final position; allow it to hang loosely in the groove adjacent to the teeth.

1. Slide the loose Range on th eshaft until the sleeve is completely seated in the teeth of each flange (the «Y» dimension is for reference and not critical). Secure the flange to the shaft. Different coupling sleeves require different degrees of alignment precision. Locate the alignment precision and check the value For your sleeve size and type in the table.
2. Check parallel alignment by placing a straight-edge across the two couplings flanges and measuring the maximum offset at various points around the coupling If the maximum offset exceeds the figure shown under Parallel in the table, realign the shaft.
3. Check angular alignment with a micrometer or caliper. Measure From the outside of one Range to the outside of the other af intervals around the periphery of the coupling. Determine the maximum and minimum dimensions without rotating the coupling. The difference between the maximum and minimum must not exceed the figure shown under Angular in the table. If a correction is necessary, be sure to recheck the parallel alignment.
4. If the coupling employs the two-piece sleeve with the wire ring, force the ring intomits groove in the center of the sleeve. It may be necessary to pry the ring into position with a blunt screw-driver.
5. Install coupling guardsper OSHA requirements.

•• CAUTION : Coupling sleeves may be thrown from the coupling assembly with substantial force when the coupling is subjected to a severe shack load or abuse. ••

TYPES: JE, JN, JNS, E & N

TYPES: H & HS

SLEEVE SIZES	MAX. RPM	PARALLEL	ANGULAR	Y	PARALLEL	ANGULAR	Y
3	9200	0.010	0.035	1.188	-----	-----	-----
4	7600	0.010	0.043	1.500	-----	-----	-----
5	7600	0.015	0.056	1.938	-----	-----	-----
6	6000	0.015	0.070	2.375	0.010	0.016	2.375
7	5250	0.020	0.081	2.563	0.012	0.020	2.563
8	4500	0.020	0.094	2.938	0.015	0.025	2.938
9	3750	0.025	0.109	3.500	0.017	0.028	3.500
10	3600	0.025	0.128	4.063	0.020	0.032	4.063
11	3600	0.032	0.151	4.875	0.022	0.037	4.875
12	2800	0.032	0.175	5.688	0.025	0.042	5.688
13	2400	0.040	0.195	6.688	0.030	0.050	6.625
14	2200	0.045	0.242	7.750	0.035	0.060	7.750
16	1500	0.062	0.330	10.250	-----	-----	-----

● Series 1000 Parts List

Centrifugal End Suction Closed Coupled Series 1000				
**	#	Parts	Standard	Options
	1	Volute Casing	Cast Iron ASTM A48 CL 30	Bronze ASTM B584 C87500
	2	Impeller	Bronze ASTM B584 C87500	Cast Iron ASTM A48 CL 30
	3	Pump Shaft	Carbon Steel - 4340 Clear Zinc Plated	----
X	4	Casing Wear Ring	Bronze ASTM B584 C87500	Stainless Steel 18-8 Open Designation
X	5	Shaft Sleeve	Bronze ASTM B584 C87500	Stainless Steel 18-8 Open Designation
X	6	Mechanical Seal	Viton/Ceramics Carbon w/Stainless Steel Spring	Various (For Assembly)
	27	Air Vent Valve Connection w/Plug	----	----
	28	Impeller Key	Carbon Steel ASTM A108 G10800	----
	31	Motor	----	----
	32	Bracket	Cast Iron ASTM A48 CL 30	----
	33	Motor Shaft Key	Carbon Steel - 1045	Stainless Steel 18-8 Open Designation
	34	Impeller Washer	Stainless Steel 18-8 Open Designation	----
	35	Impeller Bolt	Stainless Steel 18-8 Open Designation	----
X	36	Casing Gasket	Fiber Gasket (Vellumoid)	----
	37	Motor Bolt	Carbon Steel - 1045	----
	40	Water Slinger	----	----

***Recommended Spare Parts

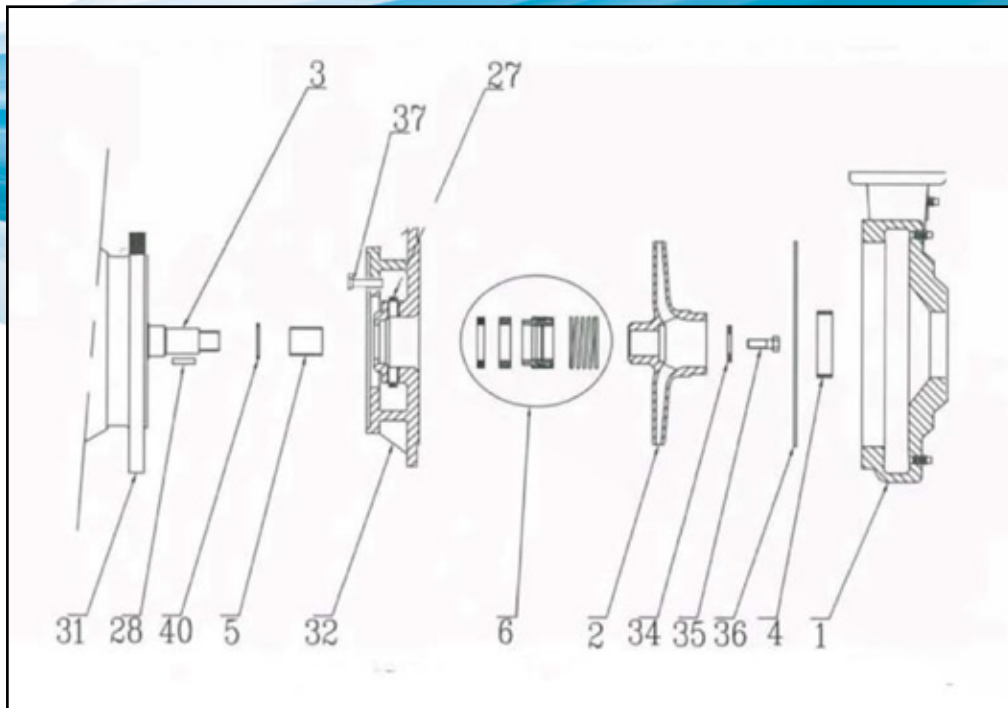

1A1 MODEL Cartridge Filter Housing



The 1A1 MODEL Cartridge Filter Housing is an all-metal, two-piece housing, featuring centerpost-type construction. The 1 A1 Model has a maximum operating temperature and pressure of 125 psig at 200°F. The 1A1 Model Cartridge Filter Housing has flow rates to up to 6 Gallons Per Minute (GPM).

APPLICABLE FILTER CARTRIDGES

Micro-Klean— III (Series U30)

Betapure—

DESIGN FEATURES

- All-metal, two-piece construction.
- Head and Sump Durable die-cast aluminum
- Mounting pads drilled to accept self-tapping screws provided with the optional mounting bracket.
- Centerpost-type design for easy cartridge changeout.

Options

- Mounting bracket; order separately.

STANDARD MODEL SPECIFICATIONS

Table 1 gives specifications for the 1A1 Model. Note that Maximum Operating Pressure is the rating for the housing only. Actual filter operating temperature depends on temperature capability of the filter cartridge used in the housing.

Operating Data	1A1 Model
Maximum Operating Pressure and Temperature	125 psi @ 200°F
Flow Rate (GPM)	See Table 2.
Materials of Construction	
Head and Sump	Die-Cast Aluminum
Centerpost	Stainless Steel
Head Gasket	Buna N & Cork
Cap-Nut Gasket	Fiber
Connection Sizes	3/8" NPTF
Cartridge Requirements	The model uses one filter cartridge. See "Cartridge Requirements" for more information.

TABLE 1 - SPECIFICATIONS

CARTRIDGE REQUIREMENTS

The 1A1 Model Cartridge Filter Housing uses one Micro-Klean III Cartridge or one Betapure Cartridge Filter.

FLOW RATES

Table 2 gives maximum flow rates in Gallons Per Minute (GPM) for the 1A1 Model Cartridge Filter Housings. Do not use Table 2 for filter sizing. Use the table as a guide only in establishing the housing flow rates. When you know the flow rate for a selected cartridge, then use the table to determine whether or not the housing is within the recommended flow rate. Remember to consider the amount of contaminant to be removed when selecting a filter.

Housing Model	Inlet / Outlet	FLOW (GPM)					
		Water	80 SSU	150 SSU	300 SSU	600 SSU	1000 SSU
1A1	3/8" NPTF	6	5	4.5	4	3.5	3

TABLE 2 - RECOMMENDED FLOW RATES

BENEFITS

- Long Service Life
- Quick and Easy Cartridge Change-out
- Reduced Down Time for Filter Change-out
- Reduced Labor Cost
- Uses Standard Filters
- Economical
- Easily Mounted to Wall or Support Structure



STANDARD MODEL DIMENSIONS

Table 3 gives dimensions in inches and shipping weight in pounds for the 1A1 Model Cartridge Filter Housing. These should be used for rough plumbing and approximate size definition. Note that figure 1 defines a length or width by a letter symbol in the top row. The square where the row and column meet is the selected dimension.

Model	A	B	C	D	Shipping Weight
1A1	6 3/16"	4 15/16"	3 1/2"	2 3/4"	3 lbs

TABLE 3. - 1A1 HOUSING DIMENSIONS

1A1 MODEL ORDERING GUIDE

Plant Code 01 Product Code 020

Model	Catalog Number	Mounting Bracket Kit*
1A1	44109-01	35581-05

* Order Separately

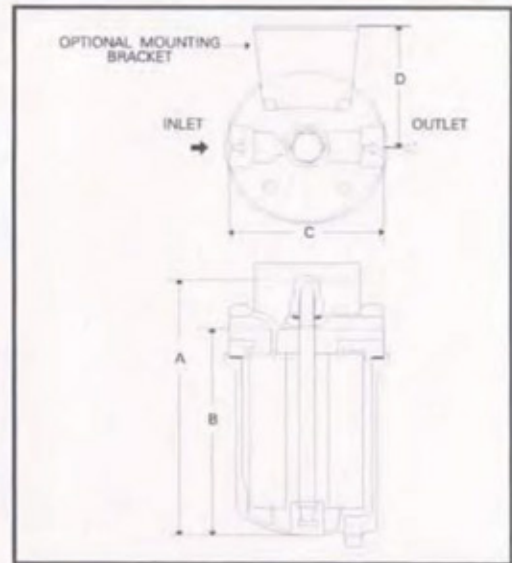

FIGURE 1. - 1A1 MODEL FILTER HOUSING

WARRANTY

Seller warrants its equipment against defects in workmanship and material for a period of 12 months from date of shipment from the factory under normal use and service and otherwise when such equipment is used in accordance with instructions furnished by Seller and for purposes disclosed in writing at the time of purchase, if any. Any unauthorized alteration or modification of the equipment by Buyer will void this warranty. Seller's liability under this warranty shall be limited to the replacement or repair, F.O.B., point of

manufacture, of any defective equipment or part which, having been returned to the factory, transportation charges prepaid, has been inspected and determined by Seller to be defective. THIS WARRANTY IS IN LIEU OF ANY OTHER WARRANTY, EITHER EXPRESSED OR IMPLIED, AS TO DESCRIPTION, QUALITY, MERCHANTABILITY, FITNESS FOR ANY PARTICULAR PURPOSE OR USE, OR ANY OTHER MATTER. Under no circumstances shall Seller be liable to Buyer or any third party for any loss of profits or



Terms and Conditions

LIMITED WARRANTY: We warrant to our immediate customer and to the ultimate consumer that products of our manufacture will be free of defects in material and workmanship under normal use and service for the following time periods, when installed and maintained in accordance with our instructions. Pumps Products: One (1) year from date of invoicing. As used herein, "the ultimate consumer" is defined as the purchaser who first uses the product after its initial installation or, in the case of product designed for non permanent installation, the first owner who used the product. It is the purchaser's or any sub-vendee's obligation to make know to the ultimate consumer the terms and conditions of this warranty. This warranty gives you specific legal rights, and there may also be other rights which vary from province to province. In the event the product is covered by the Consumer Product Warranty (1) the duration of any implied warranty associated with the product by virtue of said law is limited to the same duration as stated herein, (2) this warranty is a LIMITED WARRANTY, and (3) no claims of any nature whatsoever shall be made against us, until the ultimate consumer, his successor, or assigns, notifies us in writing of the defect, and delivers the product and/or defective part(s) freight prepaid to our factory or nearest authorized service station. THE SOLE AND EXCLUSIVE REMEDY FOR BREACH OF ANY AND ALL WARRANTIES WITH RESPECT TO ANY PRODUCT SHALL BE TO REPLACE OR REPAIR AT OUR ELECTION, F.O.B. POINT OF MANUFACTURE OR AUTHORIZED REPAIR STATION, SUCH PRODUCTS AND/OR PARTS REPAIR STATION, SUCH PRODUCTS AND/OR PARTS AS PROVEN DEFECTIVE. THERE SHALL BE NO FURTHER LIABILITY, WHETHER BASED ON WARRANTY, NEGLIGENCE OR OTHERWISE. Unless expressly stated otherwise guarantees in the nature of performance specifications furnished in addition to the foregoing material and workmanship warranties on a product manufactured by us, if any, are subject to laboratory tests corrected for field performance. Any additional guarantees, in the nature of performance specifications must be in writing and such writing must be signed by our authorized representative. Due to inaccuracies in field testing if a conflict arises between the results of field testing conducted by or for user, and laboratory test corrected for field performance, the latter shall control. Components or accessories supplied by us but manufactured by others are warranted only to the extent of and by the terms and conditions of the original manufacturer's warranty. RECOMMENDATIONS FOR SPECIAL APPLICATIONS OR THOSE RESULTING FROM SYSTEMS ANALYSES AND EVALUATIONS WE CONDUCT WILL BE BASED ON OUR BEST AVAILABLE EXPERIENCE AND PUBLISHED INDUSTRY INFORMATION. SUCH RECOMMENDATIONS DO NOT CONSTITUTE A WARRANTY OF SATISFACTORY PERFORMANCE AND NO SUCH WARRANTY IS GIVEN. This warranty shall not apply when damage is caused by (A) improper installation, (B) improper voltage (C) lightning (D) sand or other abrasive material (E) scale or corrosion build-up due to excessive chemical content. Any modification of the original equipment will also void the warranty. We will not be responsible for loss, damage or labour cost due to interruption of service caused by defective parts. Neither will we accept charges incurred by others without our prior written approval. This warranty is void if our inspection reveals the product was in a manner inconsistent with normal industry practice and/or our specific recommendations.

The purchaser is responsible for communication of all necessary information regarding the application and use of the product. UNDER NO CIRCUMSTANCES WILL BE RESPONSIBLE FOR ANY OTHER DIRECT OR CONSEQUENTIAL DAMAGES, INCLUDING BUT NOT LIMITED TO LOST PROFITS, LOST INCOME, LABOUR CHARGES, DELAYS IN PRODUCTION, IDLE PRODUCTION, WHICH DAMAGES ARE CAUSED BY ANY DEFECTS IN MATERIAL AND/OR WORKMANSHIP AND/OR DAMAGE OR DELAYS IN SHIPMENT. THIS WARRANTY IS EXPRESSLY IN LIEU OF ANY OTHER EXPRESS OR IMPLIED WARRANTY, INCLUDING ANY WARRANTY OF MERCHANTABILITY OR FITNESS FOR A PARTICULAR PURPOSE. No rights extended under this warranty shall be assigned to any other person, whether by operation of law or otherwise, without our prior written approval. If any litigation is commenced between the parties hereto for the enforcement of any rights hereunder, the successful party in subject litigation shall be entitled to receive from the unsuccessful party all costs incurred in connection therewith, including a reasonable amount of attorney's fees. YOUR ACCEPTANCE OF ANY GOODS SUPPLIED BY US, OR ON OUR BEHALF, SHALL, WITHOUT LIMITATION CONSTITUTE ACCEPTANCE OF ALL TERMS AND CONDITIONS STATED ABOVE.

PROJECT: _____
CONTRACTOR: _____
ENGINEER: _____
DATE: _____





Terms and Conditions

Our acceptance of your order is expressly conditioned on the general terms and conditions set forth below and all terms stated on the face of this form. The contract shall not include any deviating or additional terms unless expressly agreed to in writing and signed by an officer of our company.

PRICES: All prices are subject to change without notice and all shipments will be invoiced at the price in effect at the time of shipment, except when otherwise agreed to in writing by our authorized representative. Published prices are for products of our standard design and construction and any item not covered by the most recent published price list must be referred to us for special pricing. Prices do not include freight. Weights shown in price lists are approximate shipping weights. The amount of any applicable present or future tax or other government charge upon the production, sale, shipment or use of goods ordered or sold is not in the price and will be added to billing unless you provide us with an appropriate exemption certificate.

QUOTATION: Prices quoted by us are valid for 30 days from date of quotation unless we have otherwise specified in writing. Clerical errors on quotations are subject to our correction and such errors will not be binding.

CANCELLATION & REVISIONS: No purchase orders accepted and acknowledged by us may be cancelled or revised by you except with our prior written consent and upon payment of reasonable cancellation charges compensating us for all costs incurred in work done and material purchased. We reserve the right to determine what constitutes reasonable cancellation charges.

RETURN OF EQUIPMENT: No equipment shall be returned to us without first obtaining a written Returned Goods Authorization and shipping instruction from us. The returner must prepay the charges in full for transportation to our factory. Credit allowed for new, undamaged equipment of current standard design will be 80% of the invoiced price or current billing price, whichever is less. Equipment which has been used, however slight, will not be accepted. Authorization will not be given for return of equipment, (1) which would, in our opinion, result in an excess in the amount of stock we normally carry, (2) not invoiced within the last 3 months, or (3) which is non-standard and manufactured specifically to a buyer's specifications. For non-standard equipment not of our manufacture, the only credit allowed will be such credit as may be allowed by the manufacturer of such equipment. Equipment must be returned within 30 days of the issuance of the Returned Goods Authorization. No item with a net value of less than \$50.00 will be authorized for return. Unauthorized returns may be refused and/or returned freight collect.

CREDIT & PAYMENT: Payment is due as noted on our invoice. Overdue accounts are subject to a service charge. All orders are subject to approval of our credit department and we may require full or partial payment in advance. Pro rata payments shall become due as shipments are made. If the shipments are delayed by you for any cause, payments shall become due from date on which we are prepared to make shipment and storage shall be at your risk and expense. If manufacture is delayed by you for any

cause, a partial payment based upon the proportion of the order completed shall become due from the date on which we are notified of the delay.

SECURITY INTEREST: We shall have a lien on all goods sold as security for payment on the invoice price, and upon request you shall provide and execute a financing statement showing such lien.

DELIVERY: We will reasonable effort to meet your delivery requirement provided you provide us, on a timely basis, all approvals, technical data, instructions and credit approval requirements needed for release of the shipment. However, all delivery and/or shipment dates are estimates only unless we have expressly guaranteed delivery of such dates in writing at your specific request. In no event shall we have any liability if delivery is delayed by strikes, labour disturbances, material shortages, plant calamities or disaster, acts of God, government actions, civil disturbance, the failure of any pre-supposed condition of the contract, withholding shipments due to credit clearance, or other interferences beyond our reasonable control, and the date of delivery shall be extended for a period of time equal to the time lost because of any such reason.

SHIPPING: Unless you specify in writing and we acknowledge in writing, (A) goods will be boxed or crated as we may deem proper for protection against normal handling and for domestic shipment, (B) routing and manner of shipment will be at our discretion, and may be insured at your expense. An extra charge will be made for special handling. All shipments are F.O.B. point of manufacture. Delivery of goods to the initial carrier will constitute delivery to you and all goods will be shipped at your risk. A claim for loss or damage in transit must be entered with the carrier and prosecuted by you. Acceptance of material from a common carrier constitutes a waiver of any claims against us for delay, damage or loss.

GOVERNING LAW: It is understood and agreed that these Terms and Condition of Sale shall be interpreted under and pursuant to the laws of the Province of Quebec; you agree that any action at law which is related to any contract of sale brought against the company shall be filed in the appropriate court located in the Province of Quebec.

PROJECT: _____
CONTRACTOR: _____
ENGINEER: _____
DATE: _____



We are proud supplier for the following
completed and on going projects :

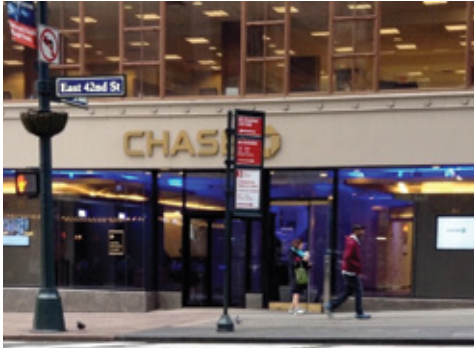

Chase Bank
60 E 42nd St, New York,
New York, USA



**Physicians Regional
Medical Center**
1345 Avenue of the
Americas, 48th Floor
New York, NY



Le St-Laurent Condos
8027 St Laurent Boul.
Brossard,
Québec, Canada



Ericsson Montreal
8400 Boulevard Décarie,
Mont-Royal,
Québec, Canada

Sales and Service:

Quebec, Canada
Tel. : (450) 621-2995
Fax : (450) 621-4995

Lake Worth
Florida, USA
33467-5749

Toronto, Canada
Tel. : +1 (647) 544-2995

www.flofab.com

SERVICE 24/7 : parts@flofab.com

