

**FLO FAB - MANUFACTURER OF PUMPS,  
TANKS, HEAT EXCHANGERS & ACCESSORIES**

REV	A
UNITS	MM

DR BY:	DATE	NAME <b>GENERAL ASSEMBLY DRAWING</b> MODEL 4900-8-5-300	PROJECTION: 		
CK BY:	DATE		PROJECT		
APPROVED:	DATE		SCALE    PAGE    OF		
		MATERIAL:	1:5	1	2

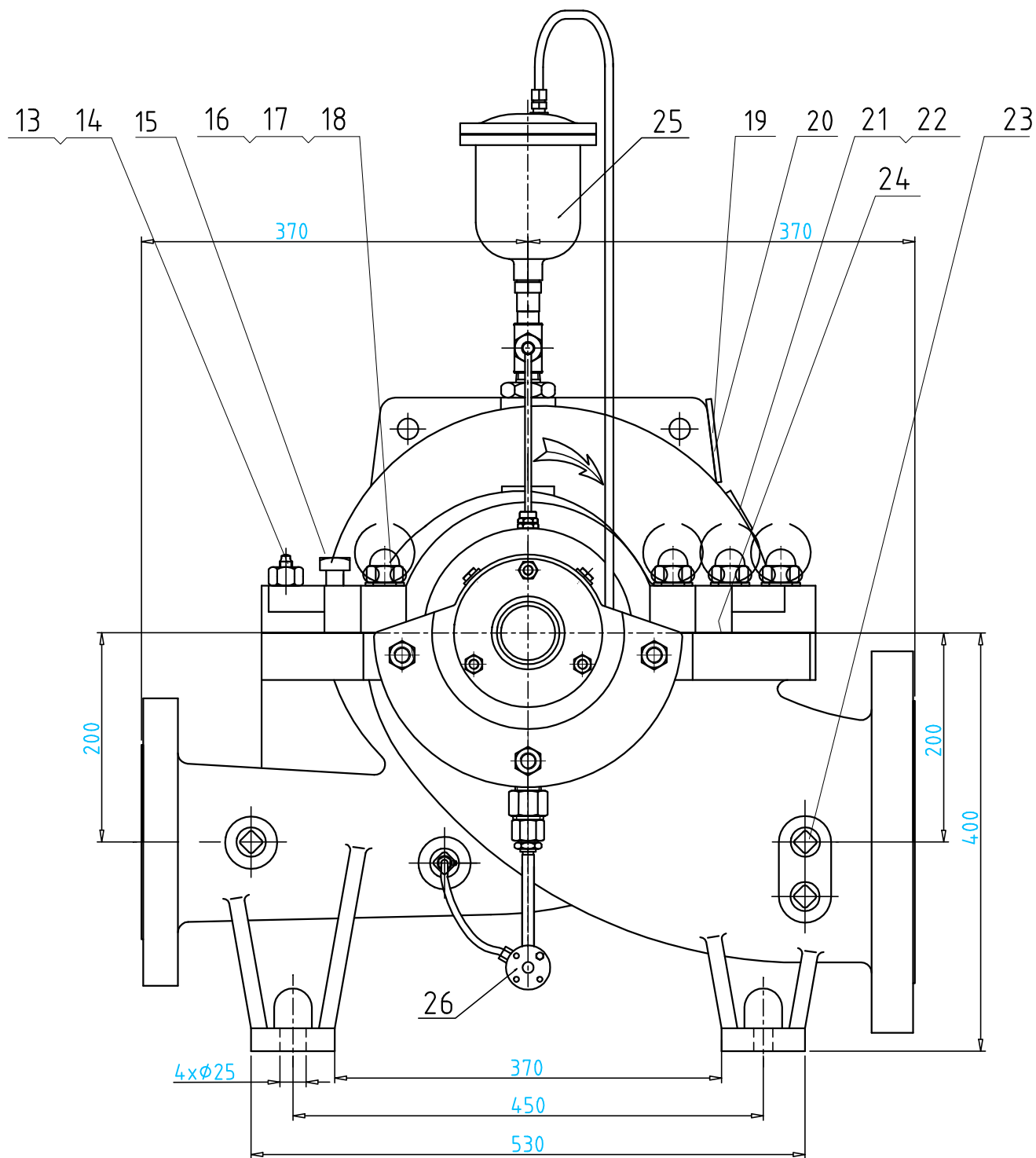

26		Blow-off Pipe	1		NPT1/2
25		<b>ARVX</b>	1	HT200	NPT1/2
24		Gasket	1	<b>Fish Paper</b>	0.3mm
23	GB/T3287	<b>Plug</b>	10	S S	NPT1/2
22		Logo	1	S S202	50x80
21	GB/T827	Rivet	4	1012	2.5x6
20	GB/T13306	Nameplate	1	S S	100x100
19	GB/T70.3	Blot	2	S S	M6x10
18	GB/T97.1	<b>Flat Washer</b>	18	S S	20
17	GB/T923	Nut	18	S S	M20
16	GB/T898	Stud	18	S S	AM20x65
15	DS-00	Top thread	4	1045	M12x80
14	GB/T881	Taper Pin	2	1045	12x100
13	GB/T6170	Nut	2	A570Gr.D	M12
12	GB/T879.1	Spring Pin	8	1066	8x20
11	GB/T93	Spring Washer	6	1066	16
10	GB/T5780	Bolt	6	A570Gr.D	M16x55
9	GB/T894.1	Shaft Circlip	1	1066	45
8	4900-8-5-300-007	Flushing Pipe	1		
7	4900-8-5-300-006B	Bearing Assembly(NDS)	1		
6	4900-8-5-300-006A	Bearing Assembly(DE)	1		
5	4900-8-5-300-005	Packing Seal Assembly	2		
4	4900-8-5-300-004	Casing Wear Ring	2	Bronze	184x212x25
3	4900-8-5-300-003	Rotor Assembly	1		
2	4900-8-5-300-002	Upper Casing	1	80-60-03	
1	4900-8-5-300-001	Lower Casing	1	80-60-03	
No.	Part No.	Part Name	Qty	Material(ASTM)	Remark



**FLO FAB - MANUFACTURER OF PUMPS,  
TANKS, HEAT EXCHANGERS & ACCESSORIES**

REV  
**A**  
UNITS  
**MM**

DR BY:	DATE	NAME <b>GENERAL ASSEMBLY DRAWING</b> MODEL 4900-8-5-300	PROJECTION: 		
CK BY:	DATE		PROJECT		
APPROVED:	DATE		SCALE    PAGE    OF <b>1:5    2    2</b>		
		PART No			
		MATERIAL:			