

**FLO FAB - MANUFACTURER OF PUMPS,
TANKS, HEAT EXCHANGERS & ACCESSORIES**

REV
A
UNITS
MM

DR BY:	DATE	NAME	PROJECTION:	
CK BY:	DATE	GENERAL ASSEMBLY DRAWING		
APPROVED:	DATE	MODEL 4900-8-5-380	PROJECT	
		PART No	SCALE	PAGE OF
		MATERIAL:	1:4	1 2

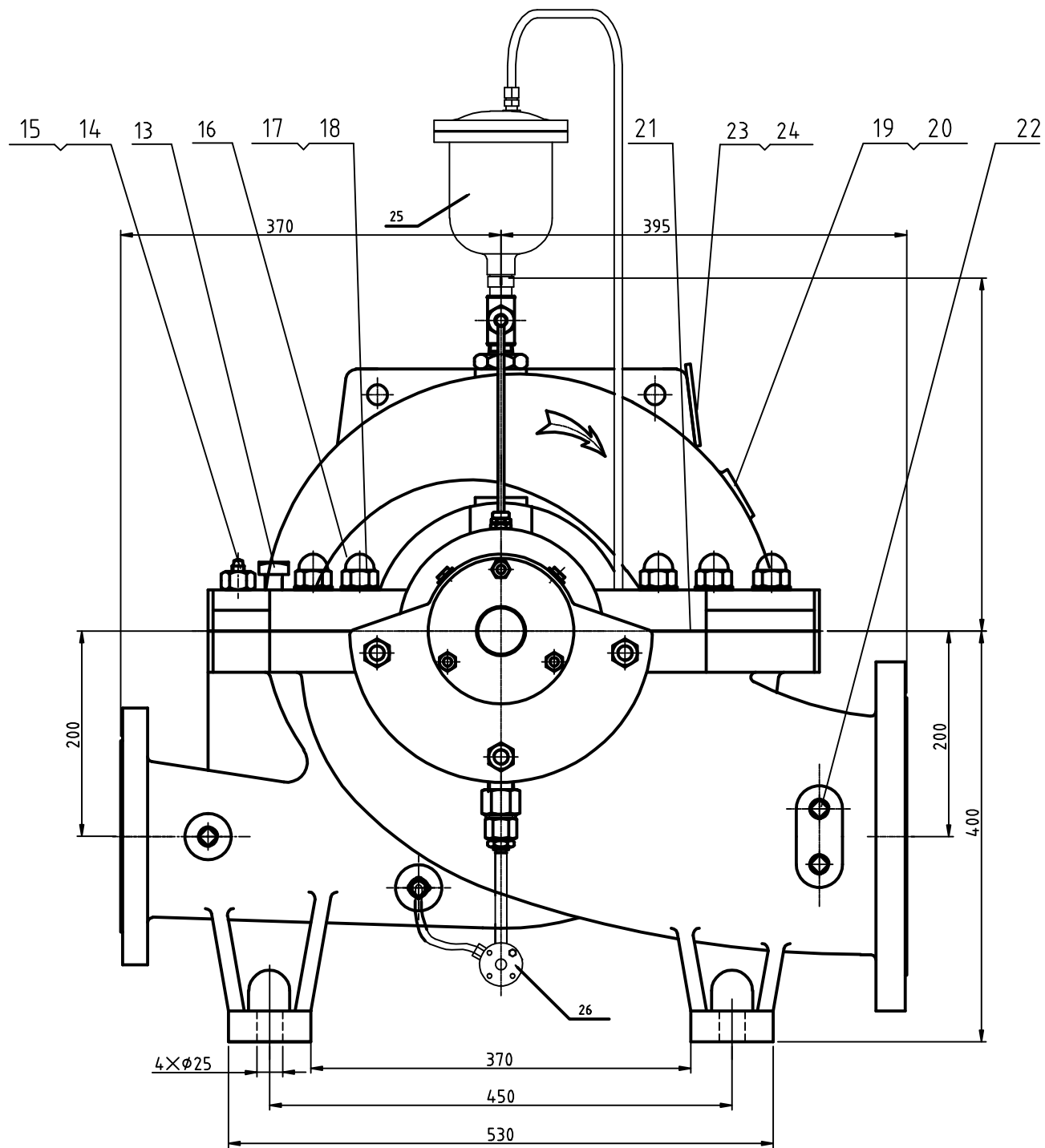

26		Blow-off Pipe	1		NPT1/2
25		ARVX	1	CLN025A (A48)	NPT1/2
24	GB/T13306	Nameplate	1	S S	80X100
23	GB/T70.3	Blot	2	S S	M6X10
22	GB/T3287	Plug	10	S S	NPT1/2
21		Casing gasket	1	Fish Paper	0.3mm
20		Logo	1	S S	
19	GB/T827	Rivet	4	1012	2.5X6
18	GB/T97.1	Flat Washer	20	S S	20
17	GB/T923	Cap nut	20	S S	M20
16	GB/T898	Stud	20	S S	AM20X65
15	GB/T881	Taper Pin	2	1045	12X100
14	GB/T6170	Nut	2	A570Gr.D	M12
13	DS-00	Top thread	4	1045	M12X80
12	GB/T93	Spring Washer	6	1066	16
11	GB/T5780	Bolt	6	A570Gr.D	M16X55
10	GB/T879.1	Spring Pin	8	1066	8X20
9	GB/T894.1	Shaft Circlip	1	1066	45
8	4900-8-5-380-007	Flushing Pipe	1		
7	4900-8-5-380-006B	Bearing Assembly(NDS)	1		
6	4900-8-5-380-006A	Bearing Assembly(DE)	1		
5	4900-8-5-380-005	Packing Seal Assembly	2		
4	4900-8-5-380-004	Casing Wear Ring	2	Bronze	212X195X25
3	4900-8-5-380-003	Rotor Assembly	1		
2	4900-8-5-380-002	Upper Casing	1	70-50-05	
1	4900-8-5-380-001	Lower Casing	1	70-50-05	
No.	Part No.	Part Name	Qty	Material(ASTM)	Remark



**FLO FAB - MANUFACTURER OF PUMPS,
TANKS, HEAT EXCHANGERS & ACCESSORIES**

REV
A
UNITS
MM

DR BY:
LH

DATE
07/05/2014

NAME
**GENERAL ASSEMBLY DRAWING
MODEL 4900-8-5-380**

PROJECTION:

CK BY:
PM

DATE

PART No

PROJECT

APPROVED:
PM

DATE

MATERIAL:

SCALE
1:4.5

PAGE
2

OF
2