

**FLO FAB - MANUFACTURER OF PUMPS,
TANKS, HEAT EXCHANGERS & ACCESSORIES**

REV	A
UNITS	MM

DR BY:	DATE	NAME	PROJECTION:		
CK BY:	DATE		PROJECT		
APPROVED:	DATE	GENERAL ASSEMBLY DRAWING MODEL 4900-8-6-460			SCALE
		PART No			PAGE
		MATERIAL:			OF
			1:5	1	2

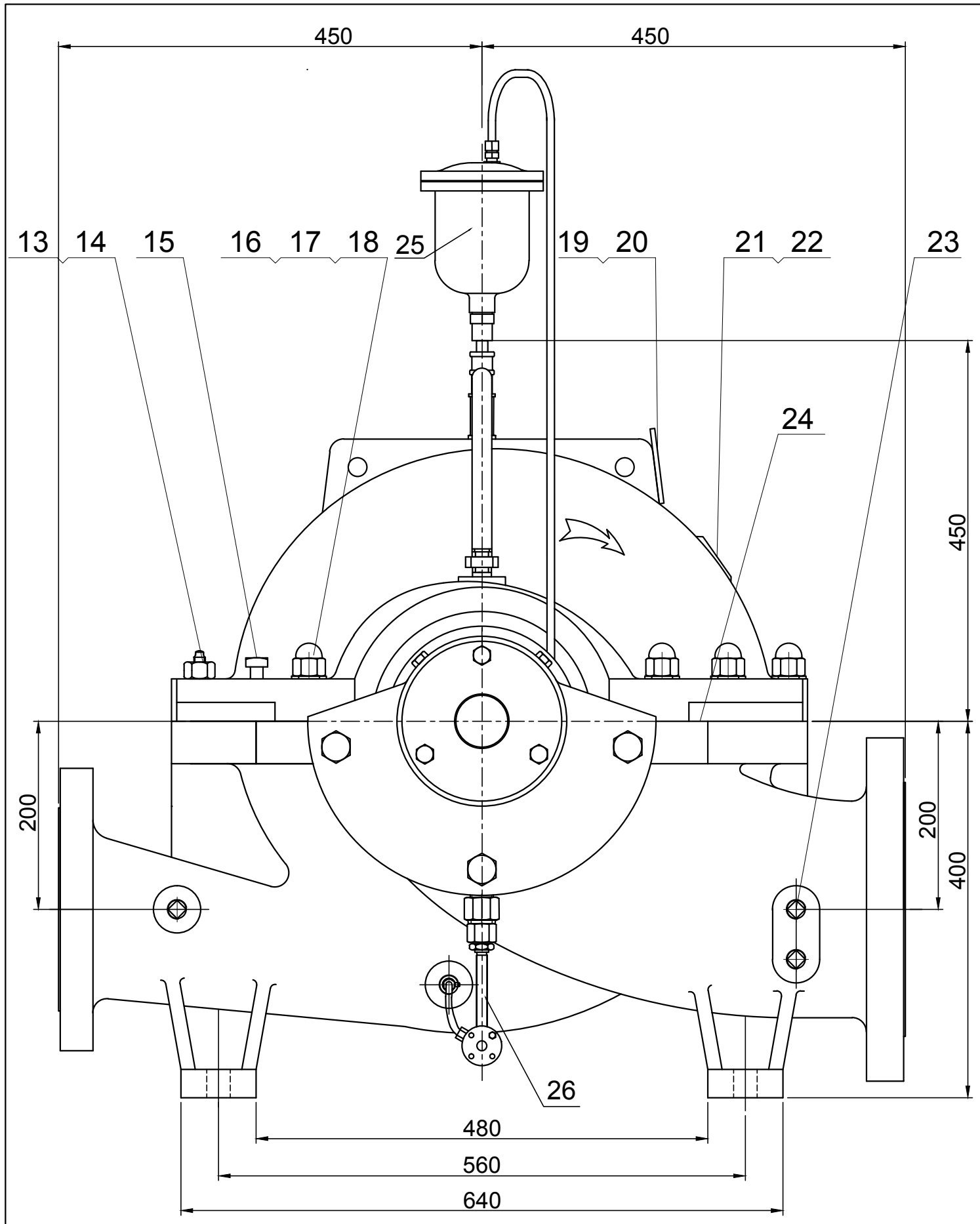

26		Blow-off Pipe	1		NPT1/2
25		ARVX	1	HT200	NPT1/2
24		Gasket	1	Fish Paper	0.3mm
23	GB/T3287	Plug	10	S S	NPT1/2
22		Logo	1	S S	50×80
21	GB/T827	Rivet	4	1012	2.5×6
20	GB/T13306	Nameplate	1	S S	100×100
19	GB/T70.3	Blot	2	S S	M6×10
18	GB/T97.1	Flat Washer	20	S S	20
17	GB/T923	Nut	20	S S	M20
16	GB/T898	Stud	20	S S	AM20×65
15	DS-00	Top thread	2	1045	M12×80
14	GB/T881	Taper Pin	2	1045	16×100
13	GB/T6170	Nut	2	A570Gr.D	M16
12	GB/T879.1	Spring Pin	8	1066	8×20
11	GB/T93	Spring Washer	6	1066	20
10	GB/T5780	Bolt	6	A570Gr.D	M20×60
9	GB/T894.1	Shaft Circlip	1	1066	55
8	4900-8-6-460-007	Flushing Pipe	1		
7	4900-8-6-460-006B	Bearing Assembly(NDS)	1		
6	4900-8-6-460-006A	Bearing Assembly(DE)	1		
5	4900-8-6-460-005	Packing Seal Assembly	2		
4	4900-8-6-460-004	Casing Wear Ring	2	Bronze	228×245×25
3	4900-8-6-460-003	Rotor Assembly	1		
2	4900-8-6-460-002	Upper Casing	1	80-60-03	
1	4900-8-6-460-001	Lower Casing	1	80-60-03	
No.	Part No.	Part Name	Qty	Material(ASTM)	Remark



FLO FAB - MANUFACTURER OF PUMPS, TANKS, HEAT EXCHANGERS & ACCESSORIES

REV	A
UNITS	MM

DR BY:	DATE	NAME	PROJECTION:	
CK BY:	DATE	GENERAL ASSEMBLY DRAWING MODEL 4900-8-6-460	PROJECT	
APPROVED:	DATE	PART No	SCALE	PAGE OF
		MATERIAL:	1:5	2 2