

NEW!

**PROFESSIONAL
CIRCULATION PUMP**

**INTELLIGENT CIRCULATOR
FOR COMMERCIAL
MARKET**

GEM · GEB

CIRCULATION PUMP



CIRCULATION PUMP

PRODUCT SERIES



COMMERCIAL
AIR CONDITIONING



COMMERCIAL
HEATING



DOMESTIC
HEATING



INTELLIGENT CIRCULATOR
FOR COMMERCIAL MARKET

INTELLIGENT CIRCULATOR FOR COMMERCIAL MARKET

GEM serial are intelligent efficiency circulation pumps equipped with permanent magnet motor and intelligent pressure control system. It adopts canned structure, the motor stator is completely canned, the rotating parts are immersed in the conveying liquid, the liquid plays the role of cooling the motor and lubricating the bearings. The product has features such as no leakage, super quiet, energy saving, high efficiency, etc.

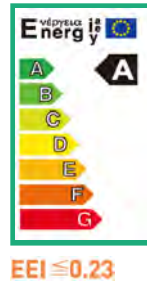

MODEL INSTRUCTION

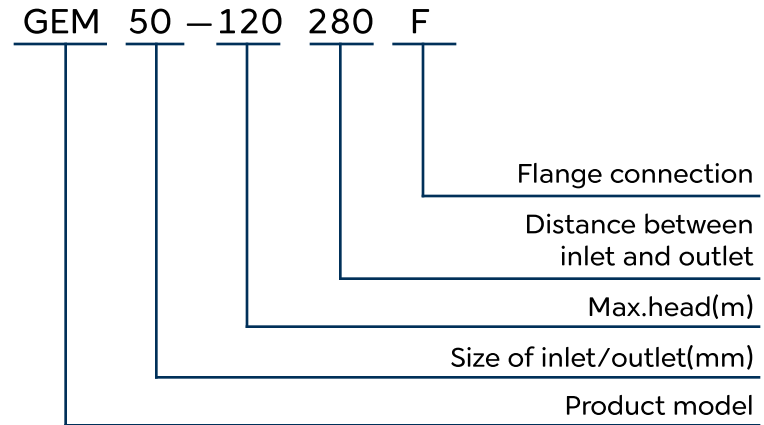

TECHNICAL SPECIFICATIONS

<p>Max. Power</p> <p>Up to 1523W 2.042 HP</p>	<p>Max. Flow</p> <p>68 m³/h 299.4 US GPM</p>	<p>Max. Head</p> <p>18m 59.1 ft.</p>	<p>System pressure</p> <p>10 Bar 145.04 PSI</p>	<p>Liquid temperature</p> <p>UP to +110°C UP to +230°F</p>
---	---	--	---	--

INTELLIGENT CIRCULATOR FOR COMMERCIAL MARKET

GEB25/32 shielded pump, used in single pipe system, double pipe system, cooling/heating water circulation system, etc, with PWM control optional, with the advantages of high comfort, low noise, low energy consumption.

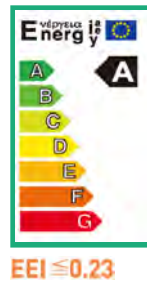

MODEL INSTRUCTION

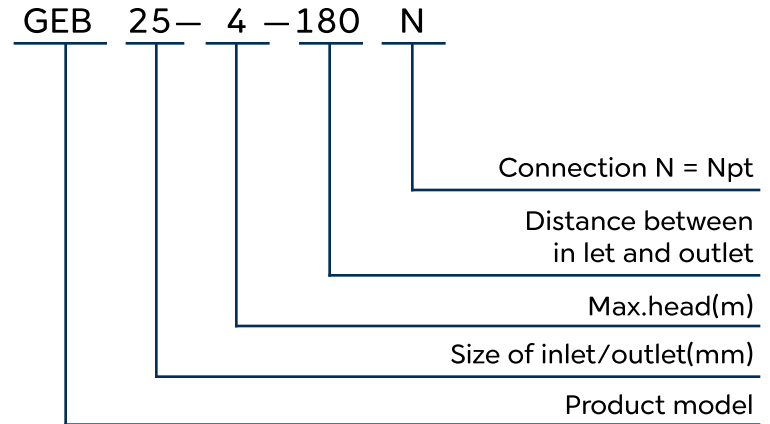

TECHNICAL SPECIFICATIONS

<p>Max. Power</p> <p>Up to 220W</p> <p>0.295 HP</p>	<p>Max. Flow</p> <p>10.5 m³/h</p> <p>46.2 US GPM</p>	<p>Max. Head</p> <p>12m</p> <p>39.4 ft.</p>	<p>System pressure</p> <p>10 Bar</p> <p>145.04 PSI</p>	<p>Liquid temperature</p> <p>UP to +95°C</p> <p>UP to +203°F</p>
---	---	---	--	--

INTRODUCTION: PRECISION COMPUTING, MULTIPLE PROTECTION

High accuracy of the algorithm

THD (Total Harmonics Distortion) 8%, power factor > 98%, power detection accuracy $\pm 3\%$



Memory
with power
restart



Fault
detection



Anti-seize
design



Overheat
protection



Overcurrent
protection

PUMP CONFIGURATION

- Motor: **High efficiency permanent magnet motor**;
- Pump shaft: **Stainless steel** shaft + **Tungsten carbide** spray treatment or brown **ceramic** shaft;
- Bearing: **Ceramic**;
- Thrust bearing: **Graphite carbon**;
- Impeller: PES + 30GF%/brass insert.

PUMP FEATURES

- Class A energy efficiency, **EEI \leq 0.23**;
- Permanent magnet motor intelligent frequency control;
- Proportional pressure mode;
Constant pressure mode;
Constant speed mode;
- Low noise, No leakage.

APPLICATION LIMITS

- Installed in the heating circulation system;
- Operating conditions:
Ambient temperature: **0~40°C; 0~104°F**
Ambient humidity: **<95%**; Liquid
temperature: **2°C~110°C; 35.6°F - 230°F**
The ambient temperature is lower than the liquid
temperature to prevent condensate liquid inside
the motor;
- Liquid material: non-corrosive, non-explosive
liquid, no solid particles, fiber and mineral oil;
- Use requirements: Do not run more than 10s
without water;

PWM CONTROL

EXTERNAL CONTROL VIA A PWM SIGNAL

The actual/setpoint level assessment required for control is referred to a remote controller. The remote controller sends a PWM signal as an actuating variable to the GEB pump. The PWM signal generator gives a periodic order of pulses to the pump (the duty cycle), according to DIN IEC 60469-1. The actuating variable is determined by the ratio between pulse duration and the pulse period. The duty cycle is defined as a ratio without dimension, with a value of 0 ... 1 or 0 ... 100%. This is explained in the following with ideal pulses which form a rectangular wave.

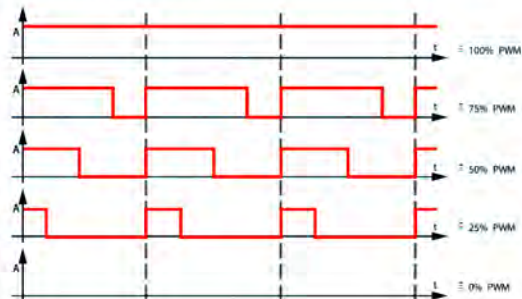
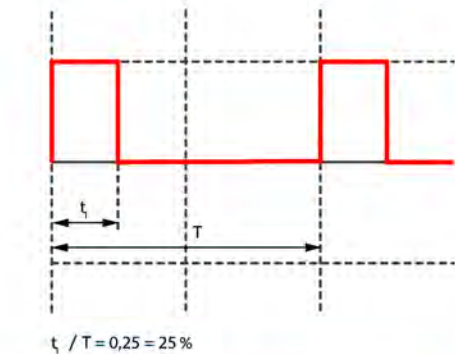

PWM GT SIGNAL LOGIC 1 (HEATING):

PWM INPUT SIGNAL [%]

- < 5 Pump runs at maximum speed
- 5-85 to Pump minimum speed decreases linearly from maximum
- 85-93 Pump runs at minimum speed (operation)
- 85-88 Pump runs at minimum speed (start-up)
- 93-100 Pump stops (Standby)

PWM SRSIGNAL LOGIC 2 (SOLAR):

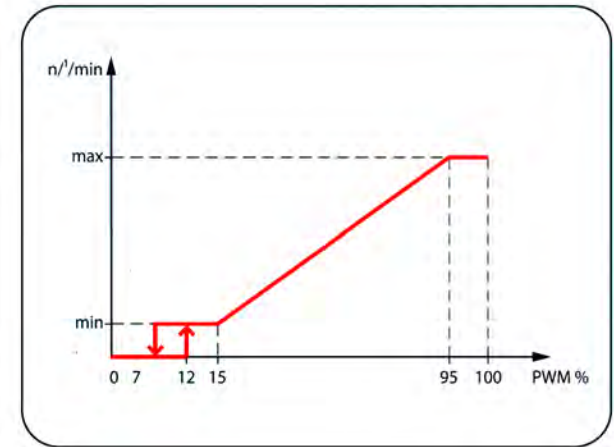

PWM INPUT SIGNAL [%]

- < 7 Pump stops (Standby)
 - 7-15 Pump runs at minimum speed (operation)
 - 12-15 Pump runs at minimum speed (start-up)
 - 15-95 Pump speed increases linearly from minimum to maximum
 - > 95 Pump runs at maximum speed
- Signal frequency: 150 Hz-5000 Hz
 Signal amplitude: 2.8V-24V
 Signal polarity: none



INTRODUCTION: YOUR PERFECT CONTROL MODE

6 Modes

Intelligent control saves time and energy



Constant pressure mode



Proportional pressure mode



Constant speed mode



AUTOADAPT mode



FLOWADAPT control mode



Temperature control mode

Constant pressure mode

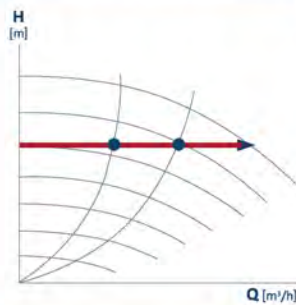

Constant pressure control is used to adjust pump performance based on actual system heat demand, but the pump performance curve will depend on the desired pump curve.

Proportional pressure mode

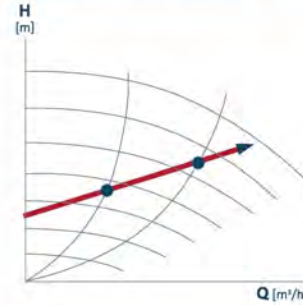

Proportional pressure control is used to adjust the pump performance according to the actual system heat demand, but the pump performance depends on the desired pump curve PP1, PP2 or PP3. Three gears are adjustable, namely small, medium and large.

Constant speed mode

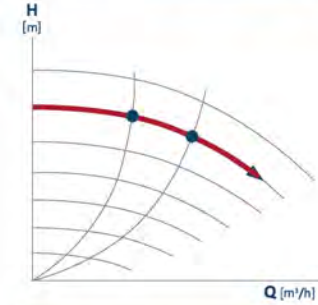

At constant speed, the pump runs at a constant speed, independent of the actual flow demand of the system, and the performance of the pump is determined according to the required power curve.

AUTOADAPT mode

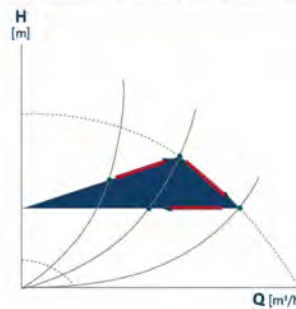

During operation, the system will regulate the performance of the pump according to the flow rate required by the user. The water pump is under proportional-pressure control. The system adaptively adjusts the pump performance within a certain area so that the pump works at a high efficiency.

FLOWADAPT control mode

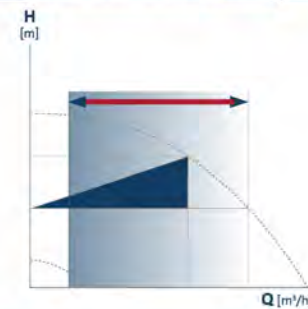

When the FLOWADAPT control mode is selected, the pump will run AUTOADAPT and ensure that the flow rate does not exceed the limited flow rate value. This control mode is suitable for systems that need to limit the maximum flow. Pumps in boiler applications where a steady flow through the boiler is required, no extra energy is used for pumping too much liquid into the system.

Temperature control mode

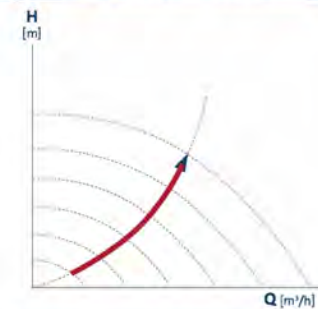

This control mode is suitable for systems with fixed system characteristic curves, and the pump can be controlled according to the temperature sensor feedback of the system to make it work under the working conditions required by the user.



LCD DISPLAY

Convenient and clear interactive function



HD display



LCD display interface interaction



Convenient and clear interactive display

INTRODUCTION: LCD DISPLAY INTERFACE INTERACTION

Home menu

🏠 Home
➔ Status
Settings
Assist

Control mode Constant Pressure	Running mode Stop
Estimated flow Low flow	Head 0.0 m

Power on
Date:2022-08-18 Time:16:30:00

Status menu

🏠 Home
➔ Status
Settings
Assist

Running status
 Performance parameter
 Warning and alarm

Running
Date:2022-08-18 Time:16:30:00

Setting menu

🏠 Home
Status
➔ Settings
Assist

Default set
 LCD off time
 Night Mode
 External sensor input port
 Analog input function

Running
Date:2022-08-18 Time:16:30:00

Assist menu

🏠 Home
Status
Settings
➔ Assist

Date Time set
 Control mode instructions
 Assisted fault advice
 Version

Running
Date:2022-08-18 Time:16:30:00

INTRODUCTION: PUMP CONFIGURATION

This product has three advantages: PES engineering plastic impeller, tungsten carbide treated stainless steel rotor shaft, and high power permanent magnet synchronous motor.

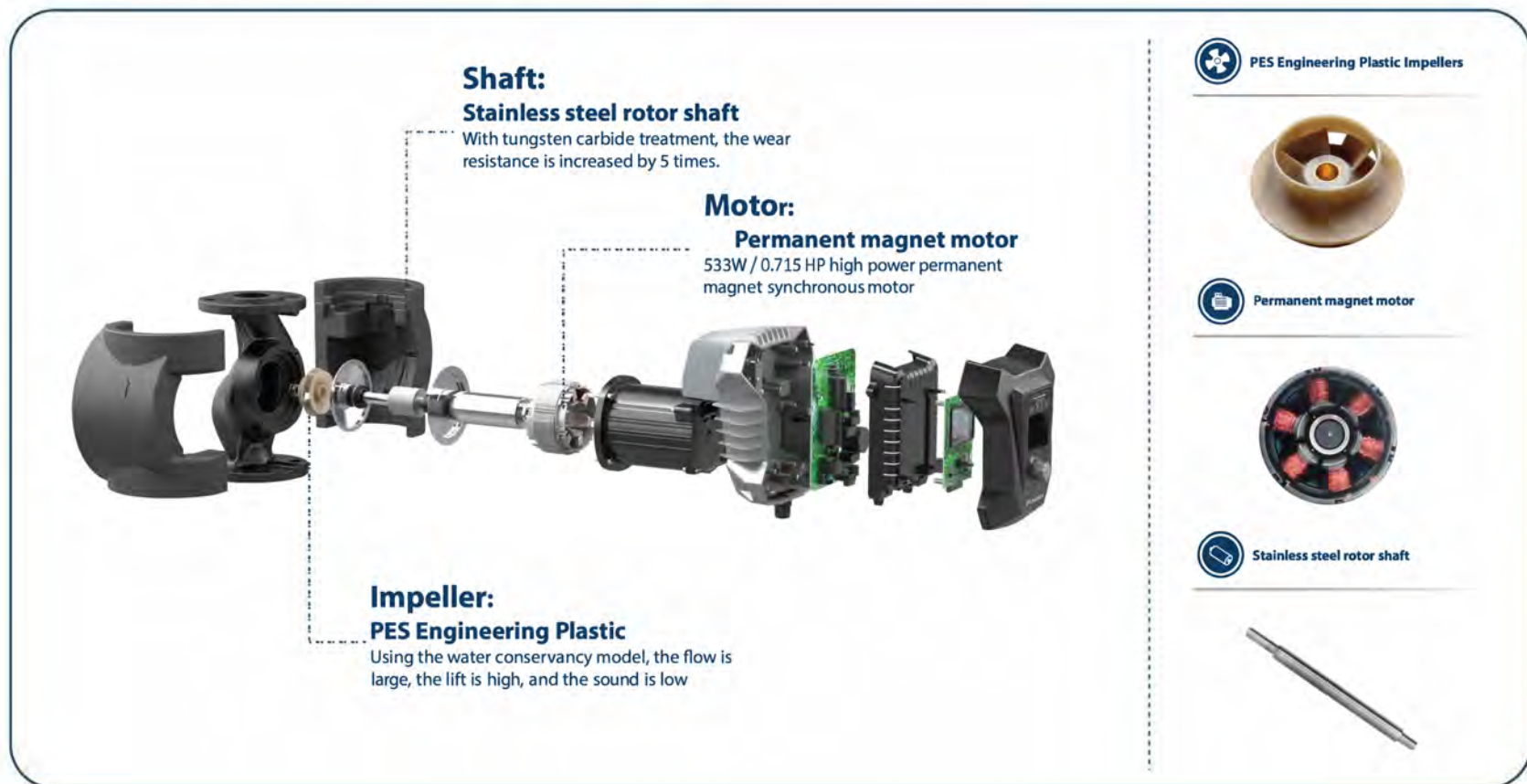

INTRODUCTION: 25/32 CALIBRE SERIES PRODUCT PARAMETERS

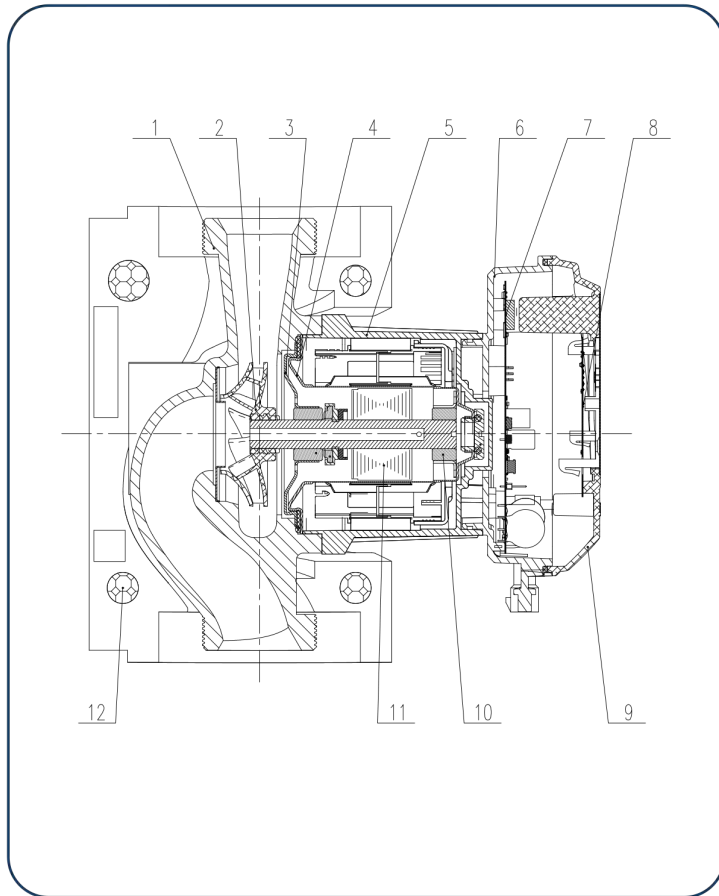

POS.	COMPONENT	CONSTRUCTION CHARACTERISTICS
1	PUMP HEAD	Cast iron surface electrophoresis treatment, exterior painting treatment
2	IMPELLER	Hydraulic model, equipped with PES engineering plastic impeller
3	STAINLESS STEEL COVER	Stainless steel material
4	SHIELDING SLEEVE	Stainless steel material, the inner wall is mirror-finished
5	BARREL	Aluminum alloy barrel, the surface is treated with black electrophoresis.
6	CASING	Plastic spray outside
7	DRIVER	Electronic device
8	CONTROL BOARD	Electronic device
9	Cover	Using high-strength plastic, soft touch texture, secondary vulcanization treatment of sealant, beautiful and fashionable appearance
10	BEARING	Brown ceramic
11	ROTOR	Brown ceramic
12	FOAM	Black EPP material, with the characteristics of heat preservation and safety protection.

INTRODUCTION:

32/40/50/60/80/100 CALIBRE SERIES PRODUCT PARAMETERS

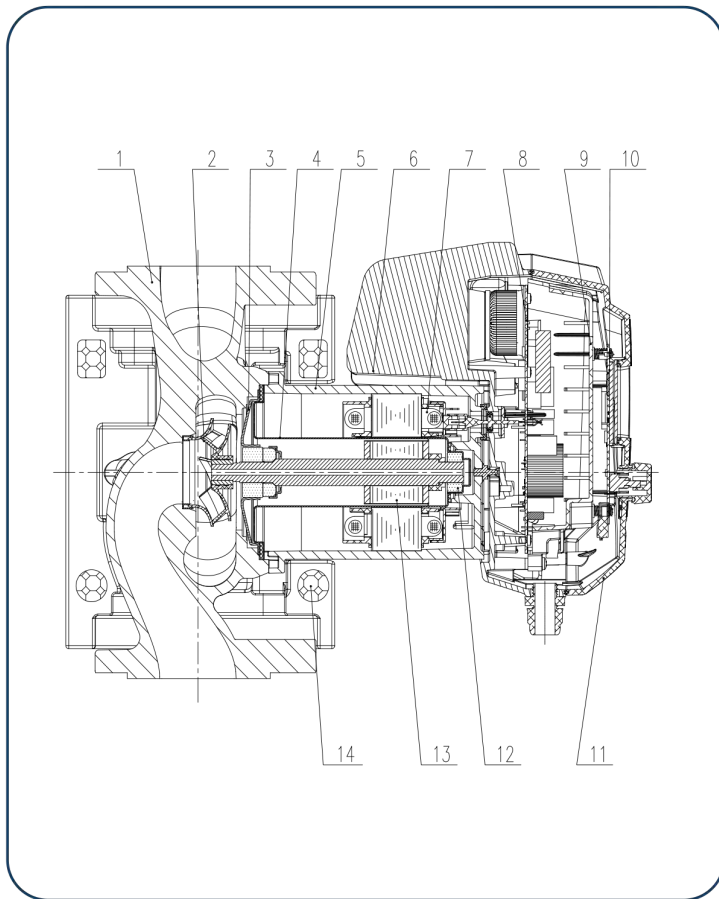

POS.	COMPONENT	CONSTRUCTION CHARACTERISTICS
1	PUMP HEAD	Cast iron surface electrophoresis treatment, exterior painting treatment
2	IMPELLER	Hydraulic model, equipped with PES engineering plastic impeller
3	STAINLESS STEEL COVER	Stainless steel material
4	SHIELDING SLEEVE	Stainless steel material, the inner wall is mirror-finished
5	BARREL	Aluminum alloy barrel, the surface is treated with black electrophoresis.
6	CASING	Plastic spray outside
7	STATOR	Full copper wire
8	DRIVER	Electronic device
9	CONTROL BOARD	Electronic device
10	ISOLATION SHIELD	Black plastic
11	Cover	Using high-strength plastic, soft touch texture, secondary vulcanization treatment of sealant, beautiful and fashionable appearance
12	BEARING	Brown ceramic
13	ROTOR	Stainless steel shaft + tungsten carbide spray treatment
14	FOAM	Black EPP material, with the characteristics of heat preservation and safety protection.

INTRODUCTION: PERFORMANCE CHART

MODEL	RATED VOLTAGE (V)	POWER FREQUENCY	INPUT POWER	MAX CURRENT	MAX FLOW	MAX HEAD (M/FT)	MAX PRESSURE (BAR/PSI)	PORT-TO -PORT I.	G.W (KG/LBS)	N.W (KG/LBS)	OUTER BOX L X W X H (MM/IN)	CONSTRUCTION	
												SS	CI
GEB25-6-180 (N)	1 x 230V 1 x 110V	50 / 60 HZ	9.. 105 W 0,012.. 0,140 HP	0,09.. 0,41 A	7,5 m ³ /h 33,0 us gpm	6 19.69	10 BAR 145.04 PSI	180 mm / 7,09 in	4 8.82	3,2 7.05	260 x 190 x 140 10.24 x 7.48 x 5.51	✓	
GEB25-12-180 (N)	1 x 230V 1 x 115V	50 / 60 HZ	9.. 220 W 0,012.. 0,295 HP	0,09.. 0,86 A 2.77 A	9,7 m ³ /h 42,7 us gpm	12 39.37	10 BAR 145.04 PSI	180 mm / 7,09 in	4 8.82	3,2 7.05	260 x 190 x 140 10.24 x 7.48 x 5.51	✓	
GEM40-120F 250 (N)	1 x 230V 1 x 110V	50 / 60 HZ	15.. 463 W 0,020.. 0,621 HP	0,18.. 2,05 A	24 m ³ /h 105,7 us gpm	12 39.37	10 BAR 145.04 PSI	281 mm / 11,06 in	17,2 37.92	15,9 35.05	310 x 249 x 423 12.20x9.80x16.65	✓	✓
GEM40-180F 250 (N)	1 x 230V 1 x 110V	50 / 60 HZ	16.. 615 W 0,021.. 0,825 HP	0,22.. 2,71 A	26,2 m ³ /h 115,4 us gpm	18 59.06	10 BAR 145.04 PSI	281 mm / 11,06 in	17,2 37.92	15,9 35.05	310 x 249 x 423 12.20x9.80x16.65	✓	✓
GEM50-120F 280 (N)	1 x 230V 1 x 110V	50 / 60 HZ	20.. 533 W 0,027.. 0,715 HP	0,22.. 2,37 A	33 m ³ /h 145,2 us gpm	12 39.37	10 BAR 145.04 PSI	281 mm / 11,06 in	19 41.89	17,5 37.47	325 x 285 x 430 12.20x9.80x16.65	✓	✓
GEM50-180F 280 (N)	1 x 230V 1 x 110V	50 / 60 HZ	22.. 769 W 0,030.. 1,031 HP	0,24.. 3,4 A	37,5 m ³ /h 165,1 us gpm	18 59.06	10 BAR 145.04 PSI	296 mm / 11,65 in	19,7 43.43	18,2 40.12	325 x 285 x 430 12.80x11.22x16.93	✓	✓
GEM65-80F 340 (N)	1 x 230V 1 x 110V	50 / 60 HZ	24.. 476 W 0,032.. 0,638 HP	0,26.. 2,11 A	40 m ³ /h 176,1 us gpm	8 26.25	10 BAR 145.04 PSI	281 mm / 11,06 in	23,1 50.93	21,3 46.96	355 x 303 x 440 13.98x11.93x17.32	✓	✓
GEM65-150F 340 (N)	1 x 230V 1 x 110V	50 / 60 HZ	31.. 1263 W 0,0416.. 1,694 HP	0,31.. 5,53 A	56 m ³ /h 246,6 us gpm	15 49.21	10 BAR 145.04 PSI	296 mm / 11,06 in	25,8 56.88	24 52.91	355 x 303 x 440 13.98x11.93x17.32	✓	✓
GEM80-120F 360	1 x 230V 1 x 110V	50 / 60 HZ	31.. 1277 W 0,0416.. 1,712 HP	0,28.. 3,16 A	60 m ³ /h 264,2 us gpm	12 39.37	10 BAR 145.04 PSI	281 mm / 11,06 in	30 66.14	28,2 62.17	365 x 363 x 467 14.37x14.29x18.39	✓	✓
GEM100-120F 450 (N)	1 x 230V 1 x 110V	50 / 60 HZ	31.. 1523 W 0,0416.. 2,042 HP	0,28.. 3,21 A	68 m ³ /h 299,4 us gpm	12 39.37	10 BAR 145.04 PSI	296 mm / 11,65 in	36,3 80.03	34,5 76.06	410 x 393 x 487 16.14x15.47x19.17	✓	✓

PERFORMANCE CHART

GEB 25-6

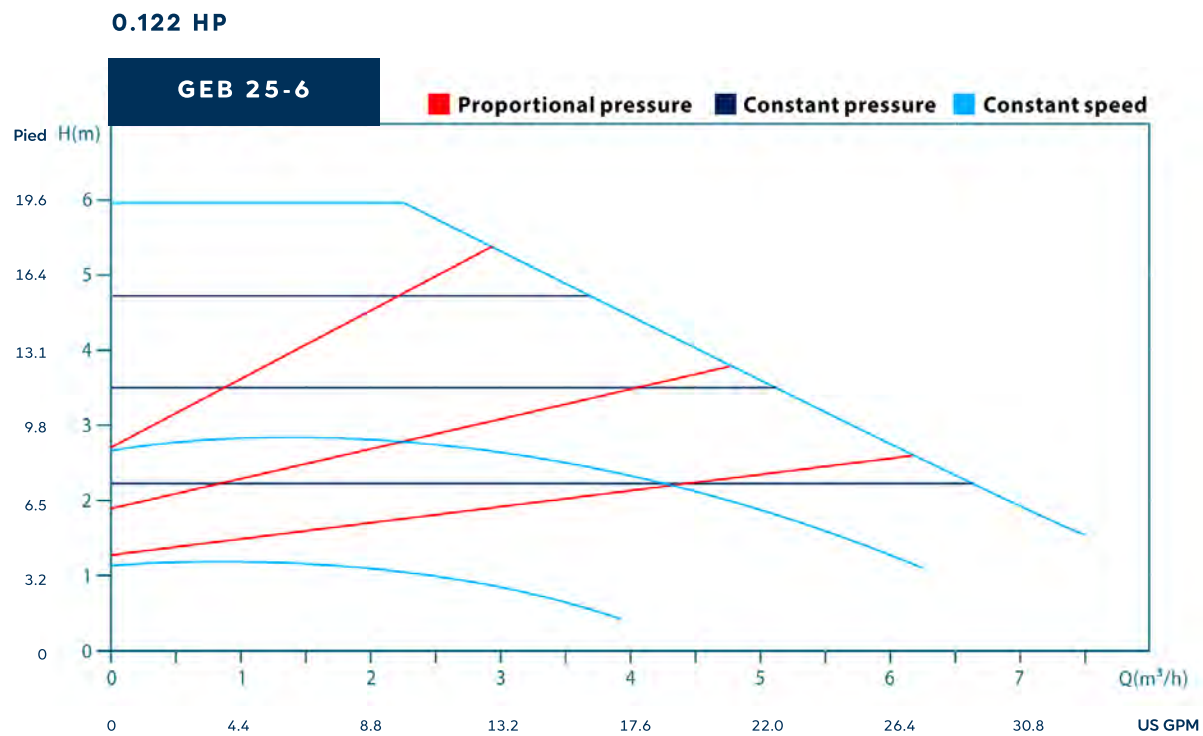

PERFORMANCE CHART

GEB 25-12

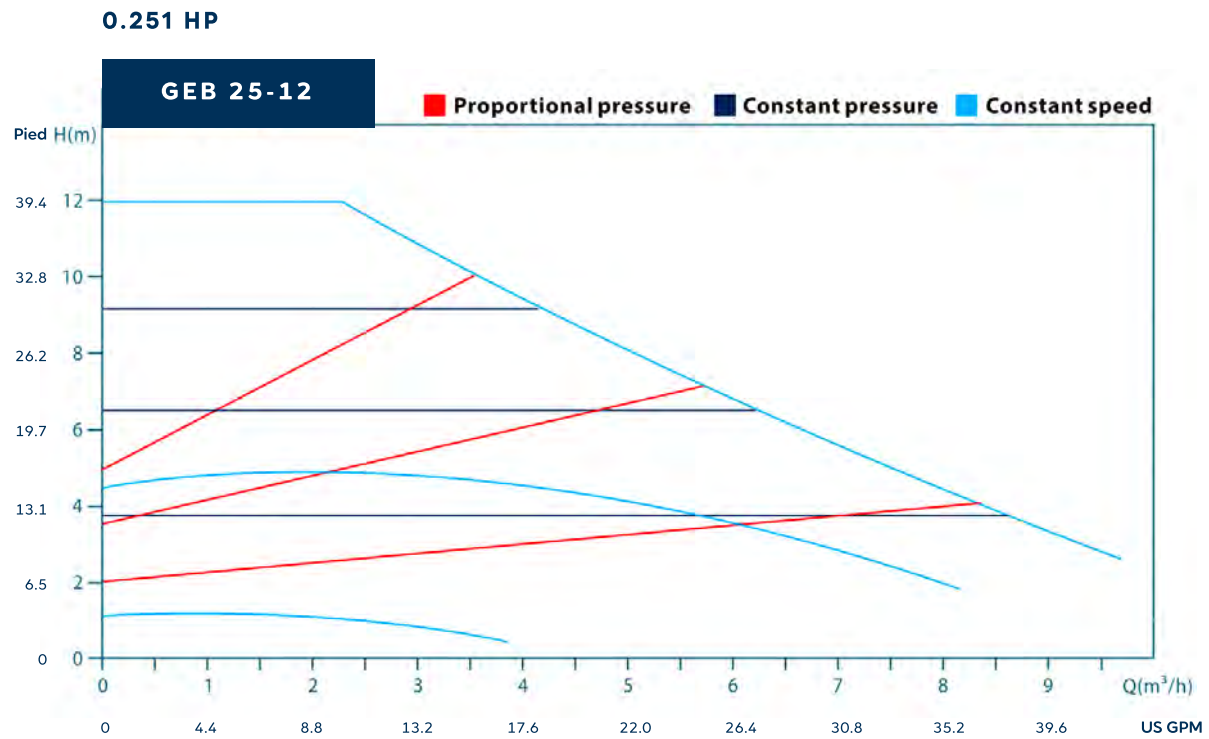

PERFORMANCE CHART

GEM 25-60

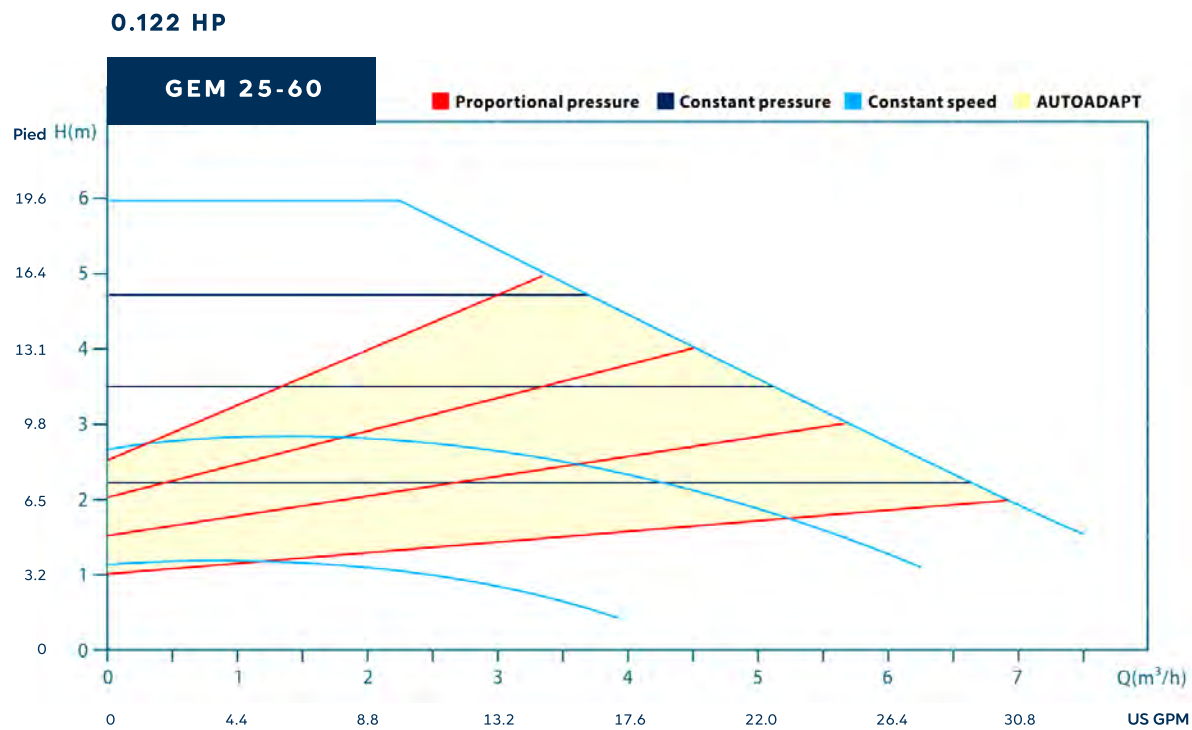

PERFORMANCE CHART

GEM 25-120

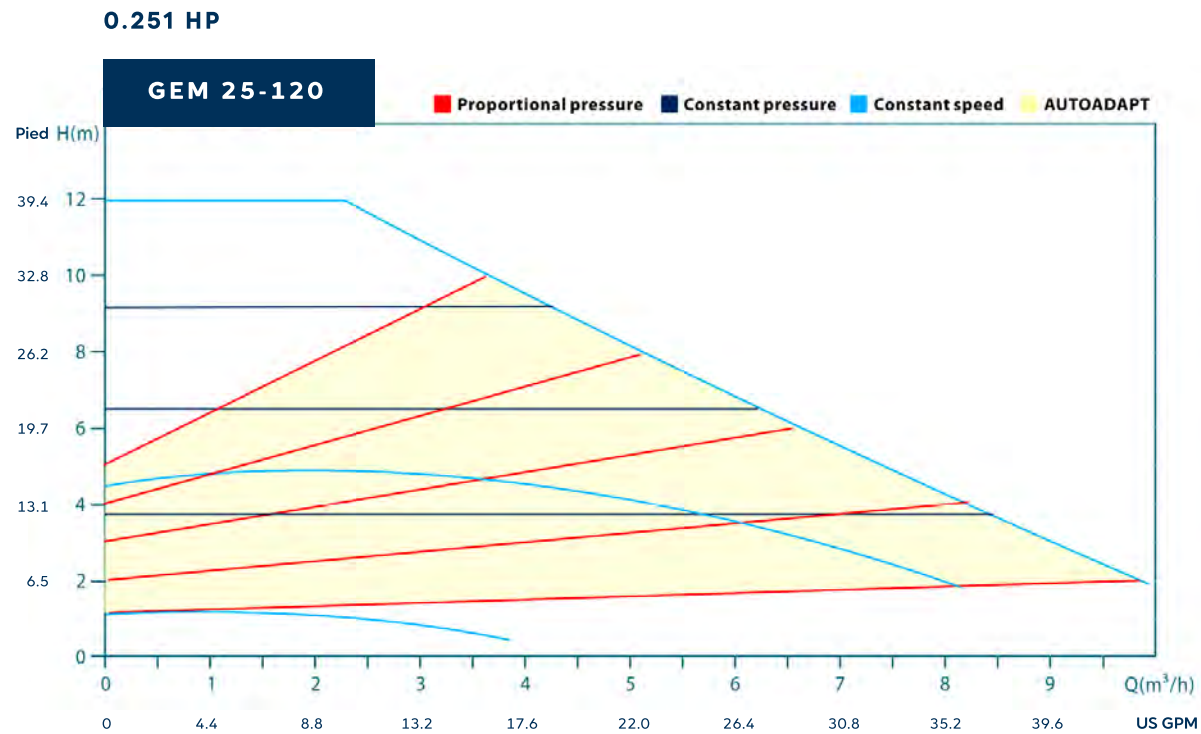

PERFORMANCE CHART

GEM 40-120F

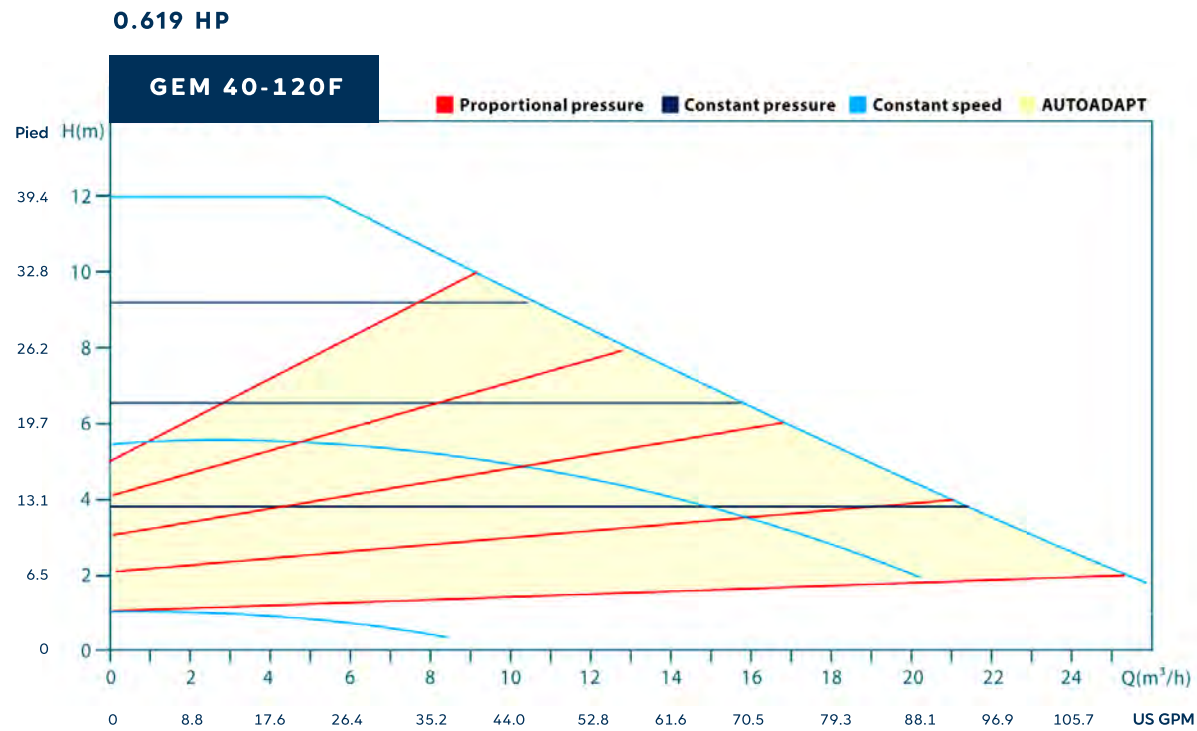

PERFORMANCE CHART

GEM 40-180F

0.823 HP

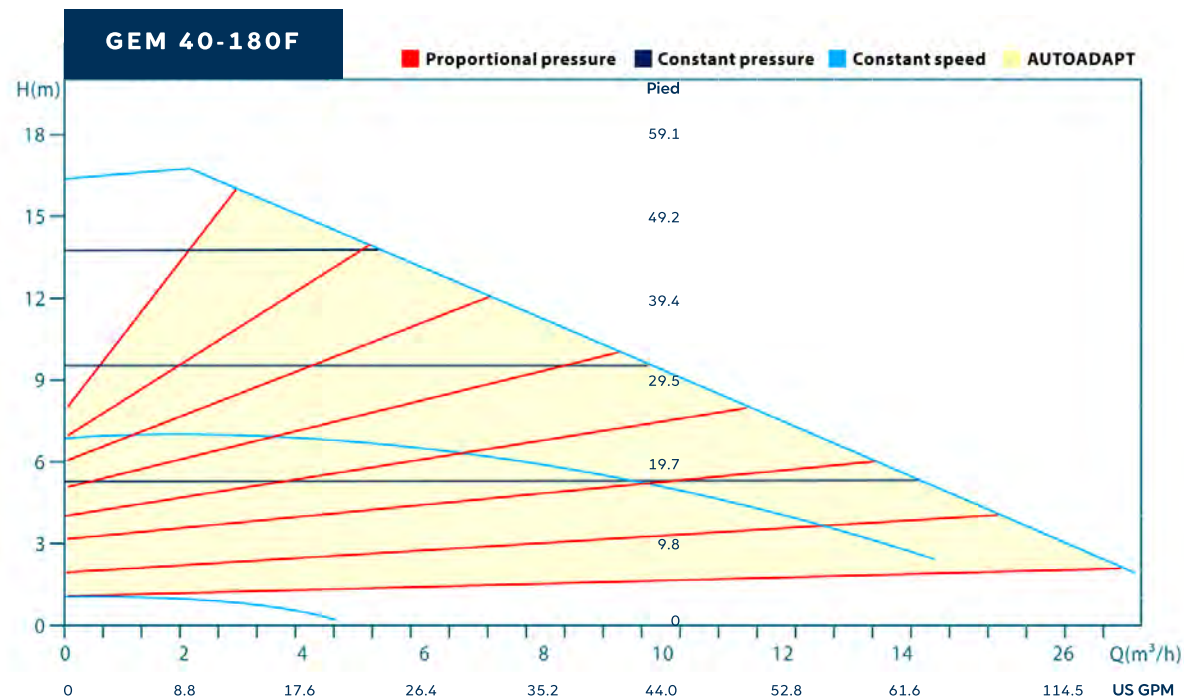

PERFORMANCE CHART

GEM 50-120F

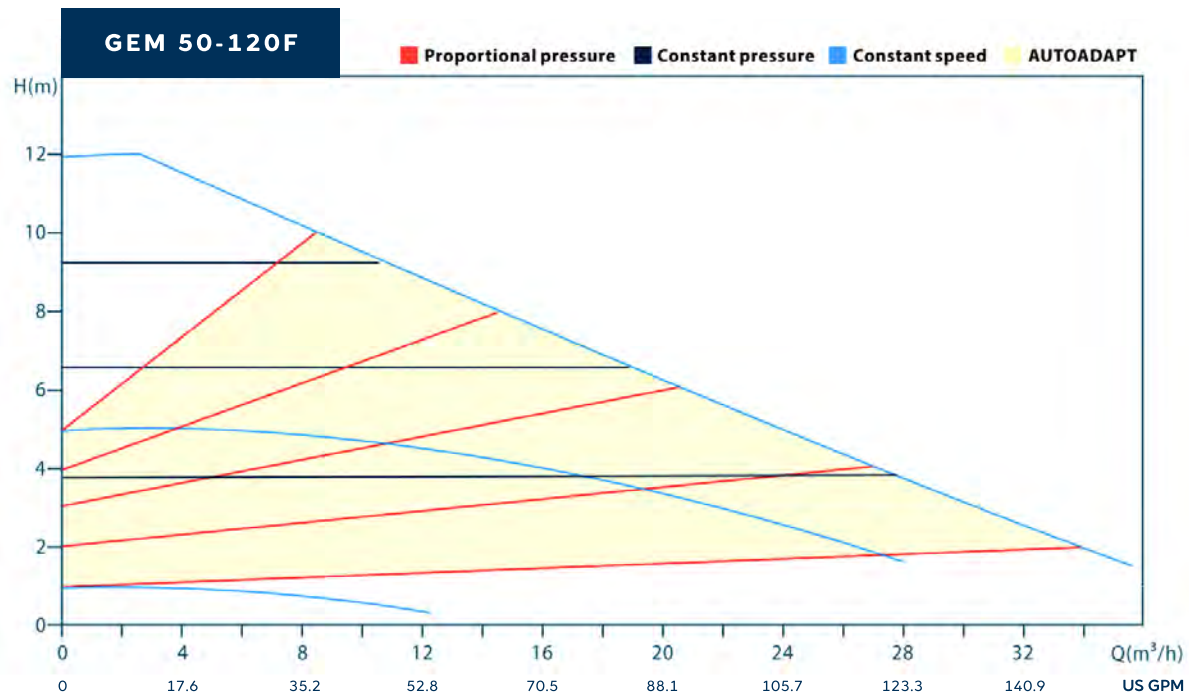

PERFORMANCE CHART

GEM 50-180F

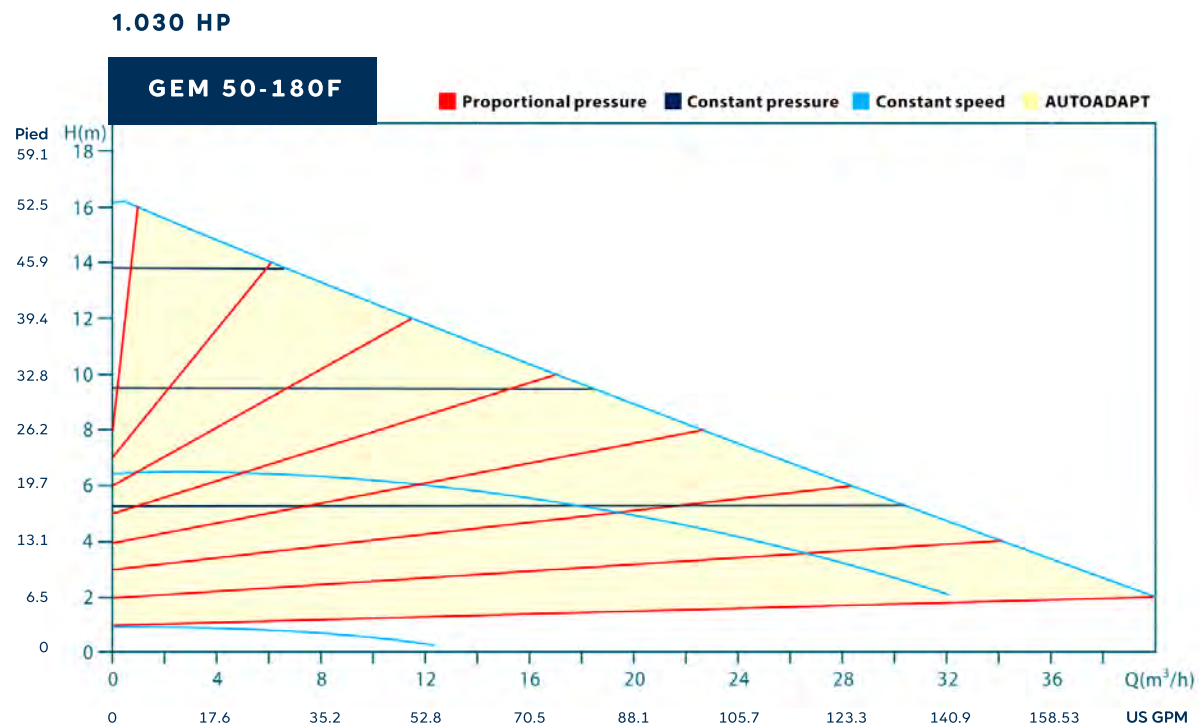

PERFORMANCE CHART

GEM 65-80F

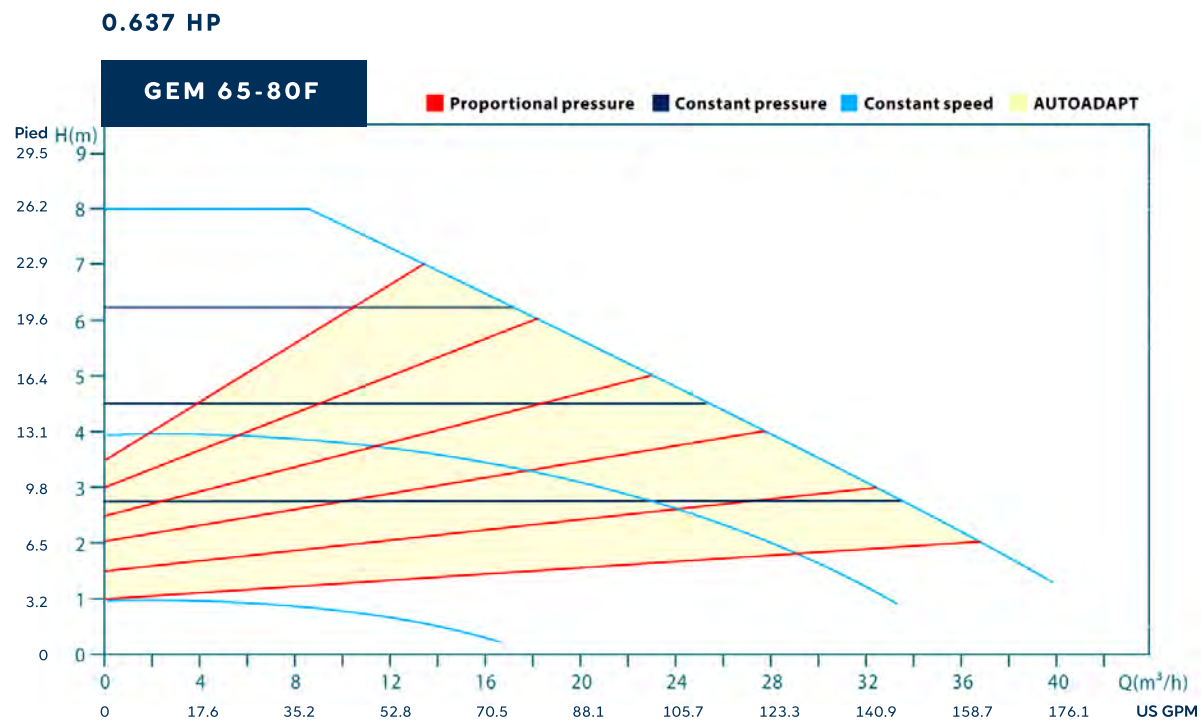

PERFORMANCE CHART

GEM 65-150F

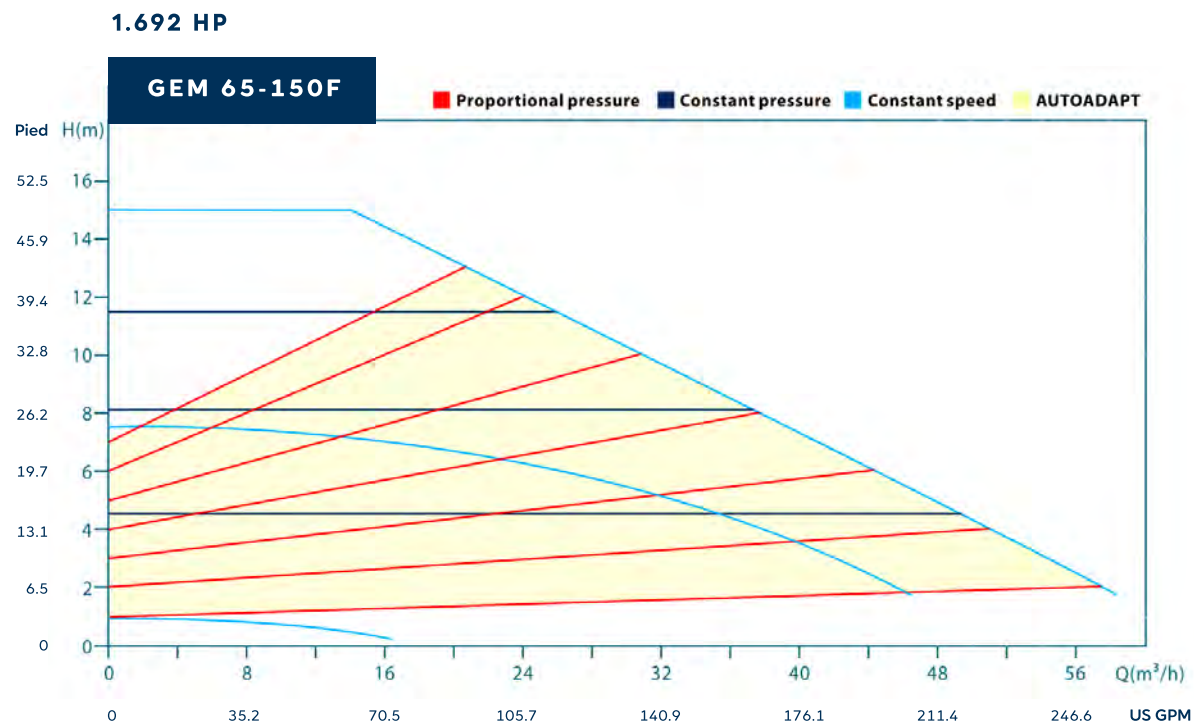

PERFORMANCE CHART

GEM 80-120F

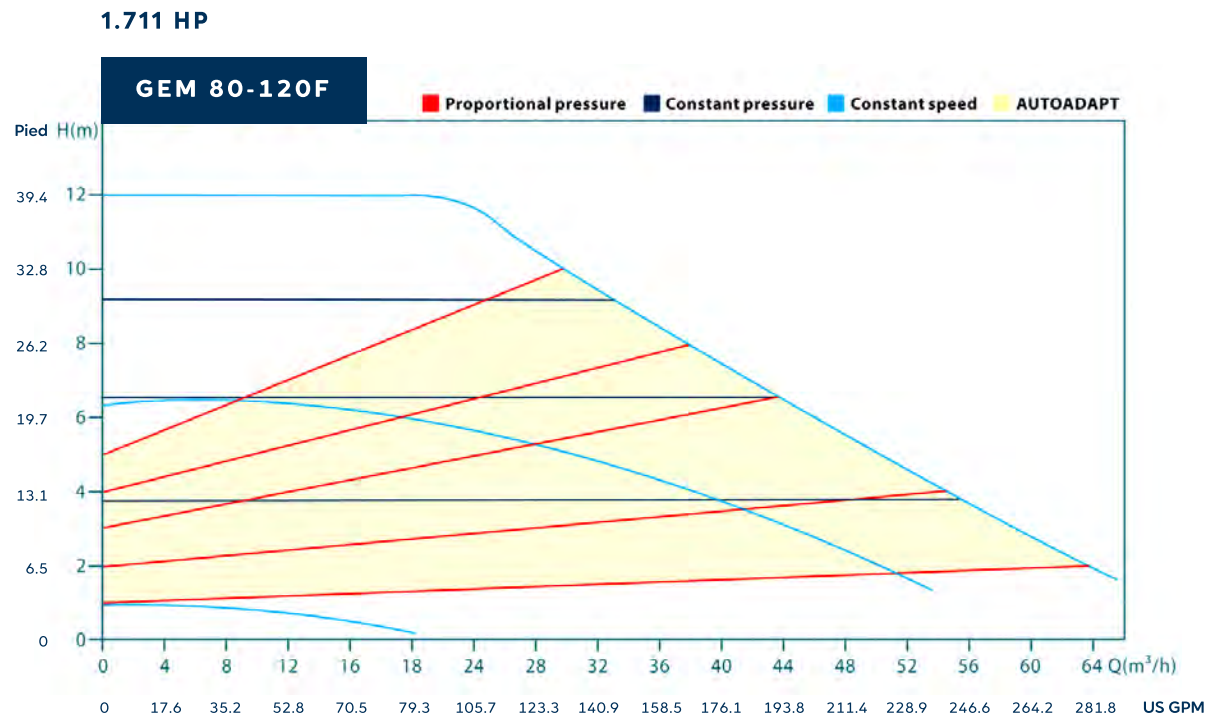

PERFORMANCE CHART

GEM 100-120F

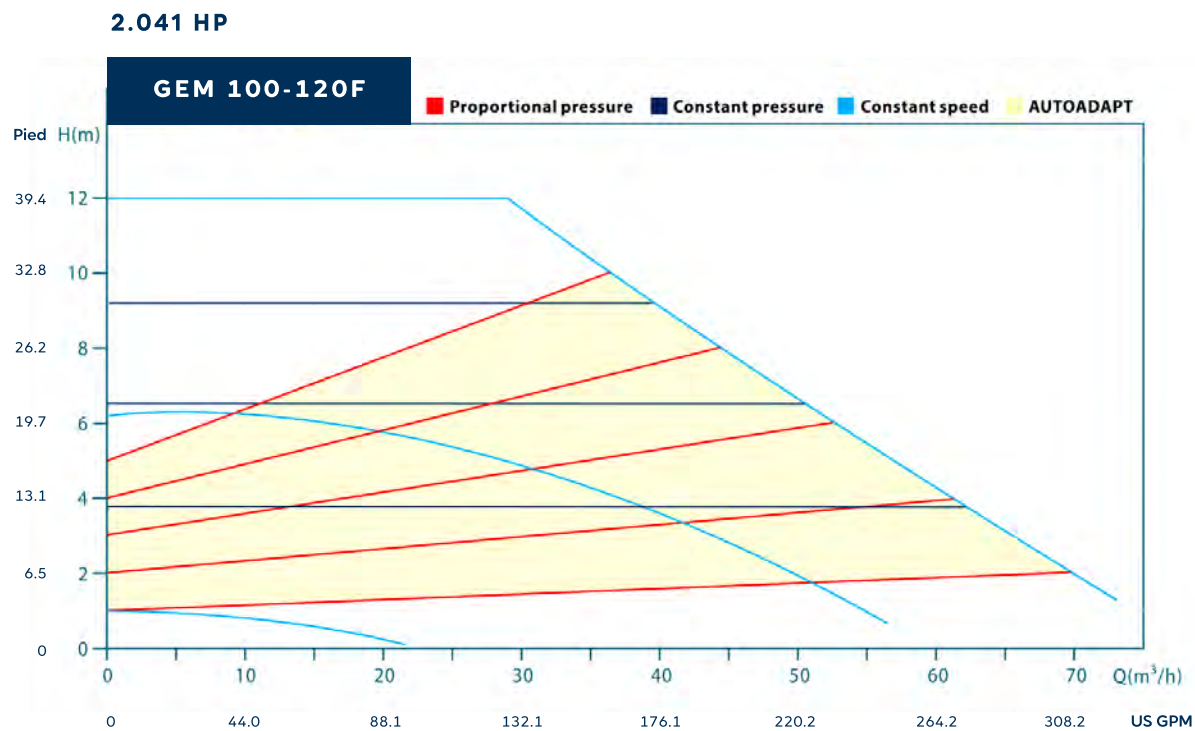

INTRODUCTION:

INSTALLATION DIMENSIONS **GEB25-6-180** | **GEB25-12-180**

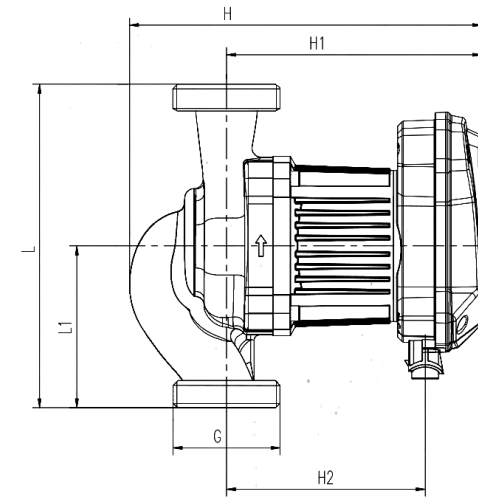
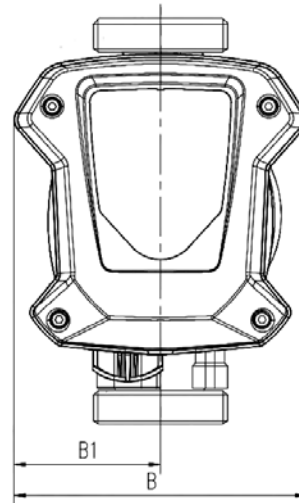

MODEL	PUMP BODY MATERIAL		DIMENSIONS							
	CAST IRON	STAINLESS STEEL	L1	L2	B	B1	H	H1	H2	G
GEB25-6-180 (N)	•	•	180 mm 7,09 in	90 mm 3,54 in	130 mm 5,12 in	65 mm 2,56 in	196 mm 7,71 in	142 mm 5,59 in	110,5 mm 0,43 in	1,5"
GEB25-12-180 (N)	•	•	180 mm 7,09 in	90 mm 3,54 in	130 mm 5,12 in	65 mm 2,56 in	196 mm 7,71 in	142 mm 5,59 in	110,5 mm 0,43 in	1,5"

INTRODUCTION:

INSTALLATION DIMENSIONS **GEM40-120F** | **GEM40-180F** | **GEM50-120F** | **GEM50-180F** | **GEM65-80F** | **GEM65-150F** | **GEM80-120F** | **GEM100-120F**

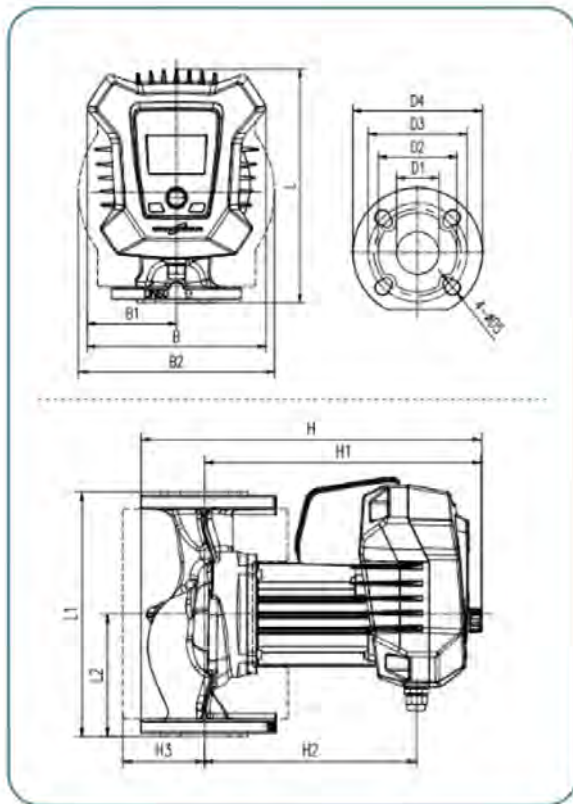

MODEL	PUMP BODY MATERIAL		DIMENSIONS (MM / IN)														
	CAST IRON	STAINLESS STEEL	L	L1	L2	B	B1	B2	H	H1	H2	H3	D1	D2	D3	D4	D5
GEM40-120F 250 (N)	•	•	281 11,06	250 9,84	125 4,92	226 8,90	113 4,45	212 8,35	382 15,04	312 12,28	242 9,53	79 3,11	40 1,57	84 3,31	100 110	150 5,91	14 19
GEM40-180F 250 (N)	•	•	281 11,06	250 9,84	125 4,92	226 8,90	113 4,45	212 8,35	382 15,04	312 12,28	242 9,53	79 3,11	40 1,57	84 3,31	100 110	150 5,91	14 19
GEM50-120F 280 (N)	•	•	296 11,65	280 11,2	140 5,51	226 8,90	113 4,45	248 9,76	389 15,32	312 12,28	242 9,53	93 3,66	50 1,97	102 4,02	110 125	164 6,46	14 19
GEM50-180F 280 (N)	•	•	296 11,65	280 11,2	140 5,51	226 8,90	113 4,45	248 9,76	389 15,32	312 12,28	242 9,53	93 3,66	50 1,97	102 4,02	110 125	164 6,46	14 19
GEM65-80F 340 (N)	•	•	281 11,06	250 9,84	125 4,92	226 8,90	113 4,45	212 8,35	382 15,04	312 12,28	242 9,53	79 3,11	40 1,57	84 3,31	100 110	150 5,91	14 19
GEM65-150F 340 (N)	•	•	296 11,65	280 11,2	140 5,51	226 8,90	113 4,45	248 9,76	389 15,32	312 12,28	242 9,53	93 3,66	50 1,97	102 4,02	110 125	164 6,46	14 19
GEM80-120F 360 (N)	•	•	281 11,06	250 9,84	125 4,92	226 8,90	113 4,45	212 8,35	382 15,04	312 12,28	242 9,53	79 3,11	40 1,57	84 3,31	100 110	150 5,91	14 19
GEM100-120F 450 (N)	•	•	296 11,65	280 11,2	140 5,51	226 8,90	113 4,45	248 9,76	389 15,32	312 12,28	242 9,53	93 3,66	50 1,97	102 4,02	110 125	164 6,46	14 19

COMPARISON CHART

FLO FAB	POWER	PORT-TO-PORT DISTANCE	FLANGE SIZE /CONNECTION TYPE	MAX HEAD (M/FT)	MAX FLOW	GRUNDFOS	ARMSTRONG	TACO
GEB40-120F 250 (N)	15.01... 463 W	250 mm	DN 40	120 m 393.7 ft	24 m ³ /h 33,0 us gpm	MAGNA3 40-120 F (N)	R20-35	0026E-F2
GEB40-180 250 (N)	16.01... 615 W	250 mm	DN 40	180 m 590.55 ft	26,2 m ³ /h 42,7 us gpm	MAGNA3 40-180 F (N)	R40-45	0034E-F2
GEM50-180F 280 (N)	22.13... 769 W	280 mm	DN 50	180 m 590.55 ft	37,5 m ³ /h 105,7 us gpm	MAGNA3 50-180 F (N)	-	VR20H
GEM65-80 340 F (N)	24.17... 476 W	340 mm	DN 65	80 m 262.47 ft	40 m ³ /h 115,4 us gpm	MAGNA3 65-80 F (N)	-	VR25L
GEM65-150F 340 (N)	30.7... 1263 W	340 mm	DN 65	150 m 492.13 ft	56 m ³ /h 165,1 us gpm	MAGNA3 65-150 F (N)	-	VR25M
GEM80-120 F	30.5... 1277 W	360 mm	DN 80	120 m 393.7 ft	60 m ³ /h 176,1 us gpm	MAGNA3 80-120 F	-	VR25H
GEM100-120 F	31.11... 1523 W	450 mm	DN 100	120 m 393.7 ft	68 m ³ /h 246,6 us gpm	MAGNA3 100-120 F	-	VR30M

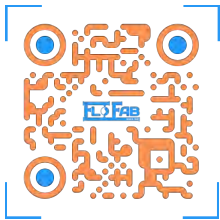

FLO FAB

service@flobab.com
quote@flobab.com
parts@flobab.com

TEL. 450-621-2995 | www.flobab.com

