



Vertical In-line Pump

Series 600

**Operation, Maintenance
& Installation Manual**



www.flofab.com

001-iom-2017-600

CAUTION!!

DO NOT RUN PUMP DRY, SEAL DAMAGE MAY OCCUR. INSPECT PUMP SEAL REGULARLY FOR LEAKS, REPLACE AS REQUIRED.

FOR LUBRICATION REQUIREMENTS, CONSULT SERVICE INSTRUCTIONS. FAILURE TO FOLLOW INSTRUCTIONS COULD RESULT IN INJURY OR PROPERTY DAMAGE. COUPLER ALIGNMENT IS REQUIRED! LEVEL AND GROUT PUMP BEFORE USE!

CHECK ALIGNMENT BEFORE GROUTING, AFTER SYSTEM 18 FILLED, AFTER SERVICING PUMP, AND AS REQUIRED.

CONSULT THE SERVICE INSTRUCTIONS FOR DETAILS.

FAILURE TO FOLLOW THESE INSTRUCTIONS COULD RESULT IN INJURY OR PROPERTY DAMAGE. FAILURE TO FOLLOW THIS INSTRUCTION MAY VOID THE WARRANTY OF THE UNIT.

VERTICAL IN LINE PUMPS

FLO FAB In Line pumps are designed to be mounted vertically in the pipe line with the motor above the pump. Center line suction and discharge keep weight evenly balanced and directly down upon the piping. No flexible connections to take up pipe misalignment are necessary since pump is not permanently connected to anything but the piping and is free to move with the expansion and contraction of the piping system. Support of the piping at the pump may be made by two pipe hangers, floor saddles or floor flanges, placed on line close to the pump.

Selection of the actual type of support is determined after consideration of the structural characteristics at the location of the pump, size and weight of both the piping and the pump, expansion and contraction of the piping, etc. In other words, the same criteria and formula for selecting piping supports are used with the additional consideration that the weight of the pump is concentrated at one point in the piping. Otherwise, piping recommendations are the same as for other types of pumps. For example, gate valves should be installed at both the pump suction and discharge to permit servicing of the pump without draining the entire system. If vertical in-line pumps are mounted in a straight horizontal run of piping, then the weight of the piping and pump system is generally supported by pipe supports, or spring hangers, and experience has shown that no additional pump support, vibration or noise isolation devices are required.

CAUTION

- A. INSTALL VERTICAL IN INLINE PUMPS WITH MOTOR IN VERTICAL POSITION.
- B. MAKE CERTAIN THE SPACE ABOVE THE PUMP IS SUFFICIENT TO GIVE CLEARANCE FOR LIFTING THE PUMP ASSEMBLY FROM THE CASING. ALSO THE SPACE AROUND THE PUMP SHOULD BE LARGE ENOUGH FOR GENERAL ACCESSIBILITY AND VENTILATION.
- C. SUPPORT PUMP ONLY BY PIPING.
- D. MANUALLY VENT ALL AIR FROM CASING.
- E. MAKE SURE SUCTION VALVE IS WIDE OPEN BEFORE STARTING MOTOR
- F. CHECK MOTOR ROTATION (CLOCKWISE LOOKING DOWN FROM TOP OF MOTOR).

FLOOR MOUNTED TYPE VERTICAL IN LINE PUMPS

Larger FLO FAB Vertical In Line pumps and Split Coupled pumps have supporting Floor plate under the casing. These pumps are to be floor mounted but other wise piped-up the same way os shown. Although Vertical In line pumps ore vibration free, it is recommended for floor mounted pumping units to provide isolation between pedestal block and foundation structvre and flexible members in pipes adjacent to pump. Typically, the natural rubber pad would hove a hardness in the range of 50 durometres, a thickness of 0.375 inches and up, depending on the loading and site conditions, and be designed for a maximum detection of 8 mm. This arrangement has been used, successfully, for many years on all types of flooring systems. The recommended arrangement diminishes noise transmission and provides adequate vibration isolation in the horizontal and vertical planes.

When Installing MFV Valve

If you are using the MFV valves as a balancing valve, you must hove these installed 10 times the pipe size diameter to obtain any type of accuracy. IF these are only to be used as a throttling, check, and shut off valve, then 5 times the pipe diameter after the pump discharge is acceptable. If the system balancing at less than 50% stem rise and this is the primary balance valve, ASHREA Standard 90.1 and Flo Fob recommend trimming the impeller to the necessary system design flow. This will reduce electrical energy consumption and comply with the Notional Energy Building Code Standard. To avoid noise problems ond possible damage to the valve I do not exceed 25 feet of pressure drop across the MFV valve.

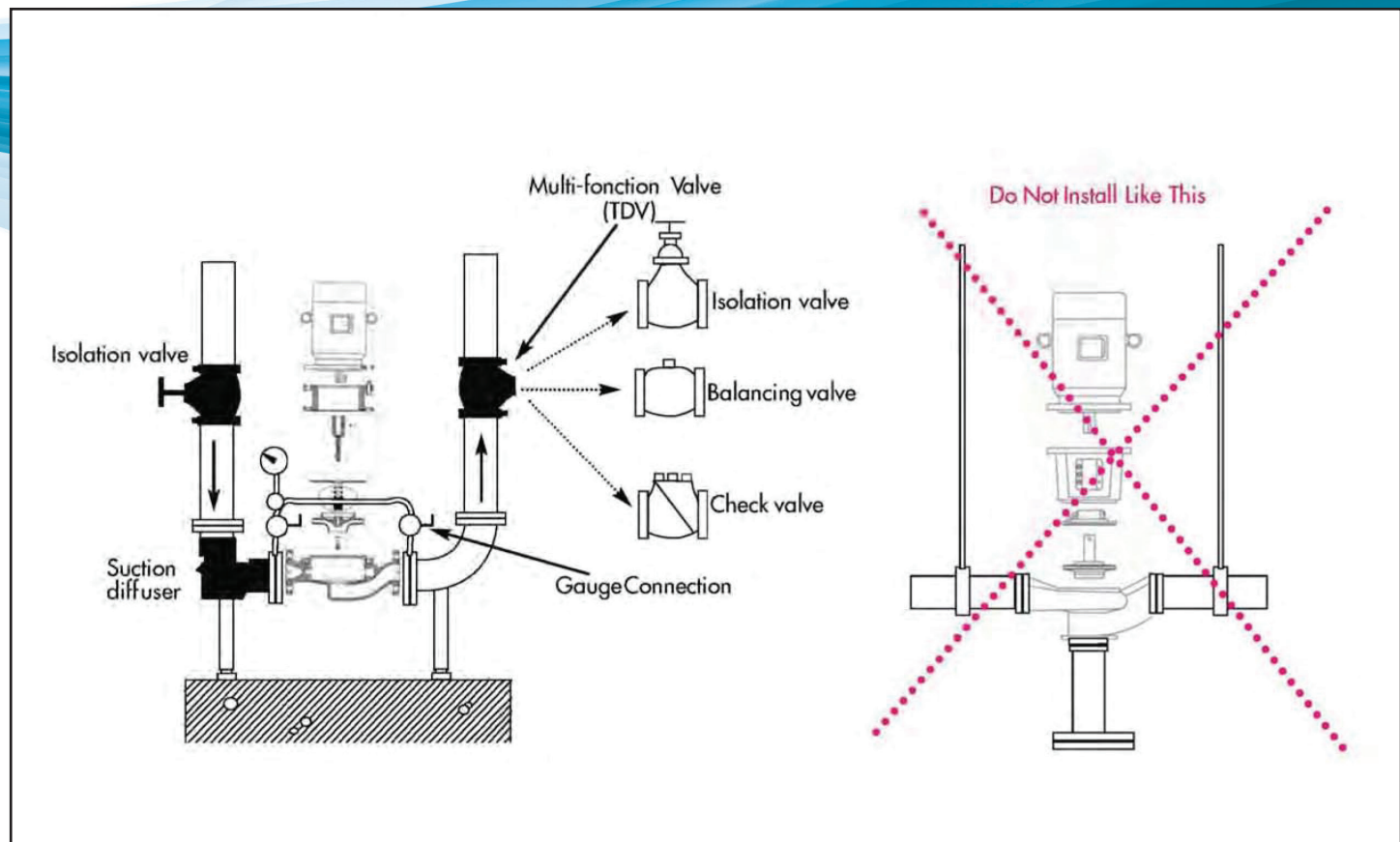

OPERATION

STARTING OF ELECTRIC MOTOR DRIVEN PUMPS

1. Before connecting motor and starter to the line:
 - 1.1. Check wiring information available inside the conduit box.
 - 1.2. Check voltage and frequency of power supply with what s shown on motor nameplate.
 - 1.3. Check current rating of overload relays and fuses against nameplate full load current value.
2. Check lubrication and pocking (see MAINTENANCE}.
3. Check if rotor is free to turn. It must be possible to revolve the rotor by hand. If the rotor drags even slightly, do not operate until the cause of trouble is located and corrected.
4. For unit with fluid drive, refer to the maintenance instructions of Auid drives.
5. If unit is for high temperature application, refer to operating instructions For high temperature pumps.
6. Prime the pump. A pump is primed when cosing and suction line are filled with liquid and when all the air contained in the pump has been allowed to escape. If pump is to operate under suction lift without foot valve, priming is done by pumping air out by means of an ejector, on exhauster or a vacuum pump.
7. Check direction of driver rotation. Proper direction is indicated by arrow on pump casing.
8. Check electric motor current as soon as motor is started to verify whether or not the mechanical load applied corresponds to the motor rating. The continuous full load current value should be within the electric motor nameplate rating with service factor taken into account.

CAUTION

- A. MAKE SURE THE GATE VALVE ON PUMP SUCTION IS FULLY OPEN AS THROTILING ON SUCTION SIDE IS HARMFUL TO THE PUMP.
- B. MAKE SURE PUMP WILL NOT RUN DRY. MOST CENTRIFUGAL PUMPS HAVE CLOSE CLEARANCES AND CANNOT RUN DRY WITHOUT SERIOUS DAMAGE RESULTING.

LONG TERM STORAGE

Here are some general suggestions for long term storage. The applicability of all, or some, of these suggestions depends on several factors such as type of equipment, length of storage, and condition of the environment.

GENERAL CARE

Drain the casing completely and dry it thoroughly, including its bearing housing and stuffing box, or seal chamber. Apply a coat of soluble rust preventive solution both internally and externally.

Cover all openings. Flanged openings (such as suction and discharge nozzles) should be covered with blind flanges with elastomer gasket. Threaded openings should be covered with steel plugs or caps.

Protect the bearing housing from moisture by placing bags of vapor phase inhibitor crystals around the housing.

Cover the equipment with industrial strength plastic, preferably transparent to allow its visual inspection, including its nameplate, without uncovering the unit.

Store the unit in its normal position in a dry place.

Inspect the unit periodically and turn the shaft a few times at least 1/4 turn. Turning the shaft prevents pitting of finished surfaces. The extra 1/4 turn is to displace the sag and prevent the shaft from developing a permanent bow.

This needs to be done at least once a month

MAINTENANCE

A systematic inspection made at regular intervals, giving special attention to the following, will ensure years of trouble-free operation.

GENERAL CARE

- 1 . Keep unit clean.
2. Avoid excessive belt tension.
3. Provide the motor with adequate overload protection.
4. Keep flying chips or other loose particles away from the ventilating openings of the motor.
5. Avoid operating the unit in overheated surroundings.
6. Guard three phase motor against single phasing which is frequently accompanied by an unusual humming sound, a drop in speed, and by excessive heating which, if continued, may burn out the motor windings.
7. Use thermometers when checking temperatures.
8. If pump is standing idle in freezing weather, pump casing and piping should be drained.

BEARINGS

1. LIFE LUBRICATED BEARINGS are heavy duty permanently lubricated, sealed type and require no maintenance
2. GREASE LUBRICATED BEARINGS require very little attention. More trouble can be caused by overcharging than by undercharging with grease. Approximately every month, depending on service, inject a small quantity of grease (Esso Andok No. 280 or equal} into bearing container after removing the grease outlet plug so that old grease is flushed out and bearing is not over-filled.

MECHANICAL SHAFT SEAL LIMITATIONS

Standard FLO FAS pumps are equipped with mechanical seals. Standard mechanical seals have Ni-resist seat, carbon washer and Viton below. Maximum recommended operating temperatures and pressures are shown below.

MOTOR HP & SPEED	SUCTION PRESSURE (PSIG)	MAXIMUM TEMPERATURE (°F)
Up to 10HP 1750 RPM	60	250
	85	225
	125	160
15 - 50HP 1750 RPM	50	250
	60	225
	100	160
Up to 15HP 3500 RPM	20	180
	125	120
20 - 60HP 3500 RPM	15	180
	115	120

CAUTION

- A. A MECHANICAL SEAL IS A PRECISION PRODUCT. HANDLE IT WITH CARE. SPECIAL CARE MUST BE TAKEN WITH THE SEALING WASHER AND SEAT. DO NOT LET THEM DROP AND TAKE PARTICULAR CARE NOT TO SCRATCH THE LAPPED FACES.
- B. NEVER RUN SEALS DRY.
- C. FOLLOW SEAL MANUFACTURER'S INSTRUCTIONS.

PREVENTIVE MAINTENANCE

1. Protect pump with a suitable strainer
2. Never pump a liquid for which the pump was not designed (check with your FLO FAS representative).
3. Keep the right amount of the right lubricant in bearings at all times, Following lubrication instructions.
4. Check periodically pump and motor alignment.
5. Any down sloping towards the pump in suction piping should be corrected.
6. See that piping puts no strain on pump casing.
7. Never allow pump to run dry.
8. Examine wearing rings at regular intervals.
9. If shaft sleeves are badly scored, replace them immediately.
10. If the liquid being pumped contains grit, o separate source of sealing liquid should be used.
11. A routine maintenance schedule should be set-up to ensure an optimum inspection and service operation in order to get the best service out of your pumping equipment.

VERTICAL IN -LINE PUMP MAINTENANCE AND SERVICE

Vertical pumps are built to operate without periodic maintenance with the exception of lubrication motor bearings with silicone grease such as Dow-Corning 44, Keystone #78 or Supermill ASU 06752 grease every 3 months. Good operational life will depend upon proper pump selection, installation and continuous water lubrication of the mechanical seals. The air vent plug must always be loosened to thoroughly vent casing before start-up and to insure water lubrication of mechanical seals.

Impurities in the system will shorten the operational life of mechanical seals due to the generally abrasive characteristics of these impurities. Most common is black iron oxide which is highly magnetic and has a tendency to form hard coating on all surfaces in contact with water. Water treatment is also an important factor in seal life. It is recommended that the chromate content in water be limited to 250 ppm.

RENEWAL PARTS

The service for which centrifugal pump is used will determine, to a great extent, the minimum number of spare parts that should be carried in stock at the installation site. The minimum for any centrifugal pump should include:

- One set of wearing rings
- One set of shaft sleeves (or a shaft if no sleeves are used)
- One set of bearings
- Sufficient stock of spare mechanical seal
- Material For gasket

When ordering spare or repair parts, always give pump serial number and full description of part(s) required.

WARRANTY

FLO FAB pumps are guaranteed against defective workmanship and material for a period of twelve months from date of shipment from Manufacturing Plant. Should the pump fail within this warranty period, our responsibility is limited to the repair or replacement of defective parts, provided such are returned to our Plant, transportation prepaid. We do not accept liability for damage or break-down from causes beyond our control, or the result of reasonable wear nor for repair made, or attempted to be made without prior sanction, nor for any consequential damage resulting from the failure of a pump. The customer will assume all labour charges incurred in making the replacement or adjustment of the parts

PLEASE NOTE THAT THERE IS **NO GUARANTEE** ON MECHANICAL SHAFT SEALS.

TROUBLE CHART (SEE KEY IN THE NEXT PAGE)

SYMPTOMS	POSSIBLE CAUSES
Pump does not deliver water	1, 2, 3, 4, 6, 11, 14, 16, 17, 22, 23
Insufficient capacity delivered	2, 3, 4, 5, 6, 7, 8, 9, 10, 11, 14, 17, 20, 22, 23, 29, 30, 31
Insufficient pressure developed	5, 14, 16, 18, 19, 20, 23, 24, 26, 27, 29, 33, 34, 37
Pump loses prime after starting	2, 3, 5, 6, 7, 8, 11, 12, 13
Pump requires excessive power	15, 16, 18, 19, 20, 23, 24, 26, 27, 29, 33, 34, 37
Stuffing box leaks excessively	24, 26, 32, 33, 34, 35, 36, 38, 39, 40
Packing has short life	12, 13, 24, 26, 28, 32, 33, 34, 35, 36, 37, 38, 39, 40
Pump vibrates or is noisy	2, 3, 4, 9, 10, 11, 21, 23, 24, 25, 26, 27, 28, 30, 35, 36, 41, 42, 43, 44, 45, 46, 47
Bearings have short life	24, 26, 27, 28, 35, 36, 41, 42, 43, 44, 45, 46, 47
Pump overheats and seizes	1, 4, 21, 22, 24, 27, 28, 35, 36, 41

KEY

SUCTION TROUBLES

1. Pump not primed.
2. Pump or suction pipe not completely filled with liquid.
3. Suction lift too high.
4. Insufficient margin between suction pressure and vapor pressure (available NPSH too low).
5. Excessive amount of air or gas in liquid.
6. Air pocket in suction line,
7. Air leakage into suction line.
8. Air leakage into pump through stuffing boxes.
9. Foot valve too small.
10. Foot valve partially clogged.
11. Inlet of suction pipe insufficiently submerged,
12. Water seal pipe plugged.
13. Seal cage improperly located in stuffing box, preventing sealing fluid entering space to form the seal.

SYSTEM TROUBLES

14. Speed too low.
15. Speed too high.
16. Wrong direction of rotation.
17. Total head of system higher than pump design head.
18. Total head of system lower than pump design head.
19. Specific gravity of liquid different than design.
20. Viscosity of liquid differs from that for which designed.
21. Operation at very low capacity.

22. Parallel operation of pumps unsuitable for such operation.

MECHANICAL TROUBLES

23. Foreign matter in impeller.
24. Misalignment.
25. Foundation not rigid.
26. Shaft bent.
27. Rotating part rubbing on stationary part.
28. Bearing worn.
29. Wearing rings worn.
30. Impeller damaged.
31. Casing gasket defective, permitting internal leakage.
32. Shaft or shaft sleeves worn or scored at the packing.
33. Packing improperly installed.
34. Incorrect type of packing for operation conditions.
35. Shaft running off-center due to worn bearings or misalignment.
36. Rotor out of balance resulting in vibration.
37. Gland too tight, resulting in no Flow of liquid to packing.
38. Failure to provide cooling liquid to water-cooled stuffing boxes.
39. Excessive clearance at bottom of stuffing box between shaft and casing, causing packing to be forced into pump interior.

40. Dirt or grit in sealing liquid, leading to scoring of shaft or shaft sleeve.

41. Excessive thrust caused by a mechanical Failure inside the pump or by the failure of the hydraulic balancing device, if any.
42. Excessive amount of grease or oil in the housing of on antifriction bearing or lack of cooling, causing excessive bearing temperature.
43. Lack of lubrications.
44. Improper installation of antifriction bearings (damage during assembly).
45. Dirt getting into bearings.
46. Rusting of bearings due to water getting into housing.
47. Excessive cooling of water-cooled bearing resulting in condensation in the bearing housing of moisture from the atmosphere.

SERIES 600 PARTS LIST

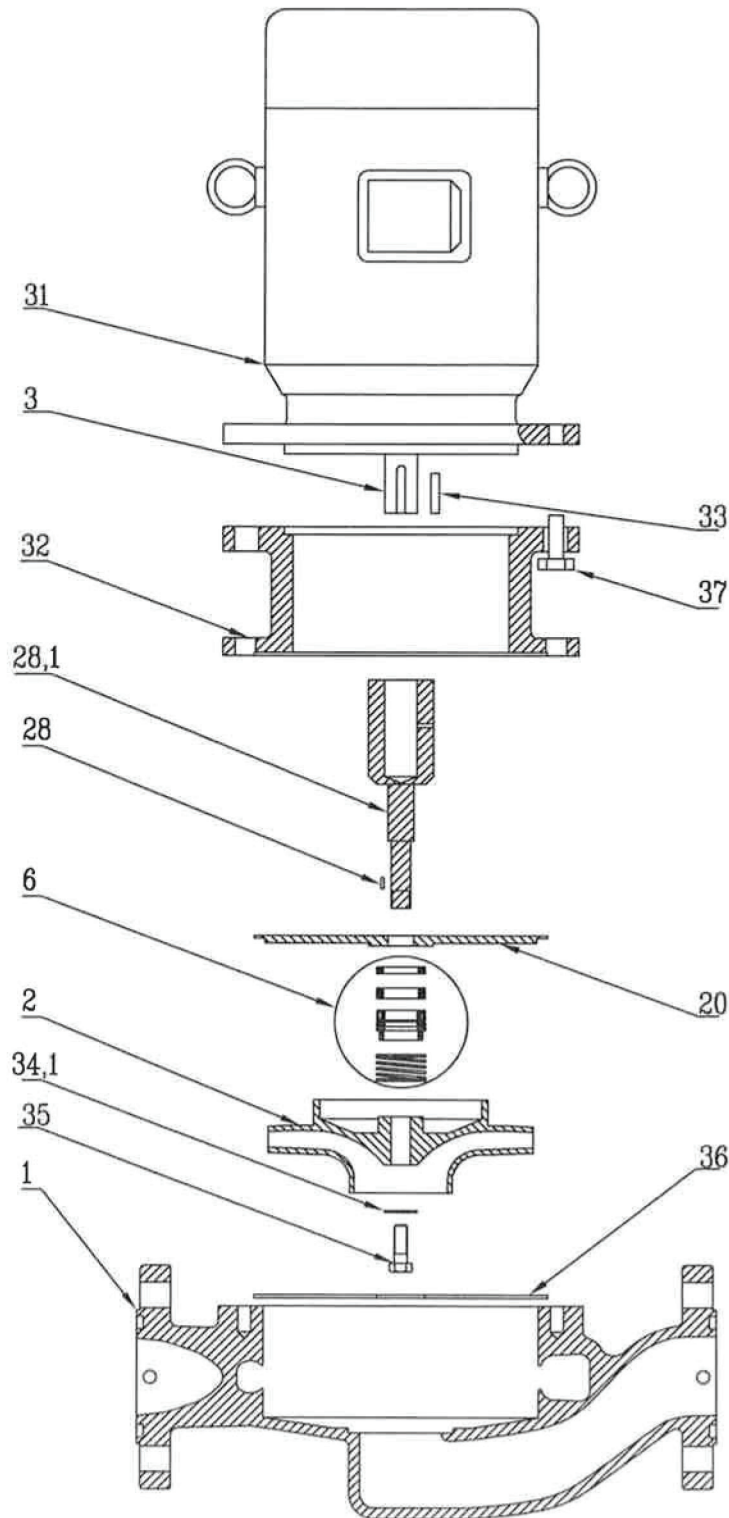

SERIAL # :	TYPE :	ID. :
SERIES : 600	MODEL :	





* Series NO	recommended spares 600 model 600-2	PART NAME	PART NUMBER	STANDARD MATERIAL	PART NUMBER	OPTIONAL MATERIAL
1		volute casing	600-2CI	cast iron ASTMA48CL 30	600-2B	bronze ASTMB584C87400
1.1		volute casing			600-2SS	stainless steel 304
1.2		volute casing			600-2DI	ductile iron 300 PSI GGG50
1.3		volute casing			600-2CS	cast steel ASTMA216WCB
1.4		companion flange (2)	810-1 3/4"	2B cast iron ASTMA48CL 30	811-1 3/4"	2B bronze ASTMB584C87400
1.5		companion flange (2)	810-2 1"	2B cast iron ASTMA48CL 30	811-2 1"	2B bronze ASTMB584C87400
1.6		companion flange (2)	810-3 1 1/4"	2B cast iron ASTMA48CL 30	811-3 1 1/4"	2B bronze ASTMB584C87400
1.7		companion flange (2)	810-4 1 1/2"	2B cast iron ASTMA48CL 30	811-4 1 1/2"	2B bronze ASTMB584C87400
1.8		companion flange (2)	810-4.1 2"	2B cast iron ASTMA48CL 30	811-4.1 2"	2B bronze ASTMB584C87400
*2.1		impeller	012-IS57-P	small vanne noryl 5.25 dia	012-IS57B	bronze ASTMB584C87400
*2.2		impeller	012-LIS57P	large vanne noryl 5.25 dia		
*2.3		impeller	LILE-2P	LOOK AT 82617		
3		motor shaft		carbon steel 4340 clear zinc plated		
*6.1		mechanical seal 56	011-S050-AR	ceramic vs carbon w/stainless steel spring		
*20		bracket faceplate	174003-071	stainless steel 304		
28		impeller key		carbon steel ASTMA108G10800		
*28.1		stub motor shaft	TCCC5-SS	stainless steel 304		
31		motor.				
32.1		bracket 56	60-LCC5	cast iron ASTMA48CL 30		bronze ASTMB584C87400
33		motor shaft key		carbon steel - 1045		stainless steel 18-8 open designation
34.1		impeller washer no 1	34	stainless steel 18-8 open designation		
35.1		impeller bolt no 1	35	stainless steel 18-8 open designation		
*36		casing gasket	G-5P	fiber gasket vellumoid		
37		motor bolts		carbon steel		



* Series	recommended spares								
NO	PART NAME	PART NUMBER	STANDARD MATERIAL	PART NUMBER	OPTIONAL MATERIAL				
1	volute casing	600-3CI	cast iron ASTMA48CL 30	600-3B	bronze ASTMB584C87400				
1.1	volute casing			600-3SS	stainless steel 304				
1.2	volute casing			600-3DI	ductile iron 300 PSI GGG50				
1.3	volute casing			600-3CS	cast steel ASTMA216WCB				
1.4	companion flange (2)	810-5 1 1/2	3B cast iron ASTMA48CL 30	811-5 1 1/2	3B bronze ASTMB584C87400				
1.5	companion flange (2)	810-6 2"	3B cast iron ASTMA48CL 30	811-6 2"	3B bronze ASTMB584C87400				
1.6	companion flange (2)	810-7 2 1/2"	3B cast iron ASTMA48CL 30	811-7 2 1/2"	3B bronze ASTMB584C87400				
*2.1	impeller	012-IS57-P	small vanne noryl 5.25 dia	012-IS57B	bronze ASTMB584C87400				
*2.2	impeller	012-LIS57P	large vanne noryl 5.25 dia						
*2.3	impeller	LILE-2P	LOOK AT 82617						
3	motor shaft		carbon steel 4340 clear zinc plated						
*6.1	mechanical seal 56	011-S050-AR	ceramic vs carbon w/stainless steel spring						
*20	bracket faceplate	174003-071	stainless steel 304						
28	impeller key		carbon steel ASTMA108G10800						
*28.1	stub motor shaft	TCCC5-SS	stainless steel 304						
31	motor.								
32.1	bracket 56	60-LCC5	cast iron ASTMA48CL 30		bronze ASTMB584C87400				
33	motor shaft key		carbon steel - 1045						
34.1	impeller washer no 1	34	stainless steel 18-8 open designation						
35.1	impeller bolt no 1	35	stainless steel 18-8 open designation						
*36	casing gasket	G-5P	fiber gasket vellumoid						
37	motor bolts		carbon steel						



* Series	recommended spares								
NO	PART NAME	PART NUMBER	STANDARD MATERIAL	PART NUMBER	OPTIONAL MATERIAL				
1	volute casing	600-4CI	cast iron ASTM A48CL 30	600-4B	bronze ASTM B584C87400				
1.1	volute casing			600-4SS	stainless steel 304				
1.2	volute casing			600-4DI	ductile iron 300 PSI GGG50				
1.3	volute casing			600-4CS	cast steel ASTM A216 WCB				
*2.1	impeller	012-IS57-P	small vanne noryl 5.25 dia	012-IS57B	bronze ASTM B584C87400				
*2.2	impeller	012-LIS57P	large vanne noryl 5.25 dia						
*2.3	impeller	LILE-2P	LOOK AT 82617						
3	motor shaft		carbon steel 4340 clear zinc plated						
*6.1	mechanical seal 56	011-S050-AR	ceramic vs carbon w/stainless steel spring						
*20	bracket faceplate	174003-071	stainless steel 304						
28	impeller key		carbon steel ASTM A108G10800						
*28.1	stub motor shaft	TCCC5-SS	stainless steel 304						
31	motor.								
32.1	bracket 56	60-LCC5	cast iron ASTM A48CL 30		bronze ASTM B584C87400				
33	motor shaft key		carbon steel - 1045						
34.1	impeller washer no 1	34	stainless steel 18-8 open designation						
35.1	impeller bolt no 1	35	stainless steel 18-8 open designation						
*36	casing gasket	G-5P	fiber gasket vellumoid						
37	motor bolts		carbon steel						

1A1 MODEL Cartridge Filter Housing



The 1A1 MODEL Cartridge Filter Housing is an all-metal, two-piece housing, featuring centerpost-type construction. The 1 A1 Model has a maximum operating temperature and pressure of 125 psig at 200°F. The 1A1 Model Cartridge Filter Housing has flow rates to up to 6 Gallons Per Minute (GPM).

APPLICABLE FILTER CARTRIDGES

Micro-Klean[™] III (Series U30)

Betapure[™]

DESIGN FEATURES

- All-metal, two-piece construction.
- Head and Sump Durable die-cast aluminum
- Mounting pads drilled to accept self-tapping screws provided with the optional mounting bracket.
- Centerpost-type design for easy cartridge changeout.

Options

- Mounting bracket; order separately.

STANDARD MODEL SPECIFICATIONS

Table 1 gives specifications for the 1A1 Model. Note that Maximum Operating Pressure is the rating for the housing only. Actual filter operating temperature depends on temperature capability of the filter cartridge used in the housing.

Operating Data	1A1 Model
Maximum Operating Pressure and Temperature	125 psi @ 200°F
Flow Rate (GPM)	See Table 2.
Materials of Construction	
Head and Sump	Die-Cast Aluminum
Centerpost	Stainless Steel
Head Gasket	Buna N & Cork
Cap-Nut Gasket	Fiber
Connection Sizes	3/8" NPTF
Cartridge Requirements	The model uses one filter cartridge. See "Cartridge Requirements" for more information.

TABLE 1 - SPECIFICATIONS

CARTRIDGE REQUIREMENTS

The 1A1 Model Cartridge Filter Housing uses one Micro-Klean III Cartridge or one Betapure Cartridge Filter.

FLOW RATES

Table 2 gives maximum flow rates in Gallons Per Minute (GPM) for the 1A1 Model Cartridge Filter Housings. Do not use Table 2 for filter sizing. Use the table as a guide only in establishing the housing flow rates. When you know the flow rate for a selected cartridge, then use the table to determine whether or not the housing is within the recommended flow rate. Remember to consider the amount of contaminant to be removed when selecting a filter.

Housing Model	Inlet / Outlet	FLOW (GPM)					
		Water	80 SSU	150 SSU	300 SSU	600 SSU	1000 SSU
1A1	3/8" NPTF	6	5	4.5	4	3.5	3

TABLE 2 - RECOMMENDED FLOW RATES

HS.1A1.0590

BENEFITS

- Long Service Life
- Quick and Easy Cartridge Change-out
- Reduced Down Time for Filter Change-out
- Reduced Labor Cost
- Uses Standard Filters
- Economical
- Easily Mounted to Wall or Support Structure





STANDARD MODEL DIMENSIONS

Table 3 gives dimensions in inches and shipping weight in pounds for the 1A1 Model Cartridge Filter Housing. These should be used for rough plumbing and approximate size definition. Note that figure 1 defines a length or width by a letter symbol in the top row. The square where the row and column meet is the selected dimension.

Model	A	B	C	D	Shipping Weight
1A1	6 3/16"	4 15/16"	3 1/2"	2 3/4"	3 lbs

TABLE 3. - 1A1 HOUSING DIMENSIONS

1A1 MODEL ORDERING GUIDE

Plant Code 01 Product Code 020

Model	Catalog Number	Mounting Bracket Kit*
1A1	44109-01	35581-05

* Order Separately

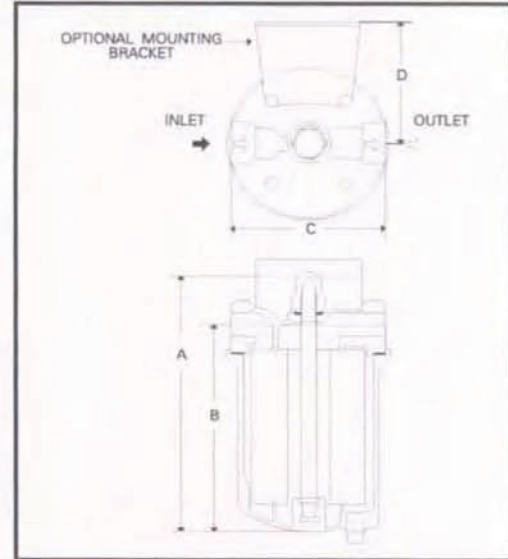

FIGURE 1. - 1A1 MODEL FILTER HOUSING

WARRANTY

Seller warrants its equipment against defects in workmanship and material for a period of 12 months from date of shipment from the factory under normal use and service and otherwise when such equipment is used in accordance with instructions furnished by Seller and for purposes disclosed in writing at the time of purchase, if any. Any unauthorized alteration or modification of the equipment by Buyer will void this warranty. Seller's liability under this warranty shall be limited to the replacement or repair, F.O.B., point of

manufacture, of any defective equipment or part which, having been returned to the factory, transportation charges prepaid, has been inspected and determined by Seller to be defective. THIS WARRANTY IS IN LIEU OF ANY OTHER WARRANTY, EITHER EXPRESSED OR IMPLIED, AS TO DESCRIPTION, QUALITY, MERCHANTABILITY, FITNESS FOR ANY PARTICULAR PURPOSE OR USE, OR ANY OTHER MATTER. Under no circumstances shall Seller be liable to Buyer or any third party for any loss of profits or



Terms and Conditions

LIMITED WARRANTY: We warrant to our immediate customer and to the ultimate consumer that products of our manufacture will be free of defects in material and workmanship under normal use and service for the following time periods, when installed and maintained in accordance with our instructions. Pumps Products: One (1) year from date of invoicing. As used herein, "the ultimate consumer" is defined as the purchaser who first uses the product after its initial installation or, in the case of product designed for non permanent installation, the first owner who used the product. It is the purchaser's or any sub-vendee's obligation to make know to the ultimate consumer the terms and conditions of this warranty. This warranty gives you specific legal rights, and there may also be other rights which vary from province to province. In the event the product is covered by the Consumer Product Warranty (1) the duration of any implied warranty associated with the product by virtue of said law is limited to the same duration as stated herein, (2) this warranty is a LIMITED WARRANTY, and (3) no claims of any nature whatsoever shall be made against us, until the ultimate consumer, his successor, or assigns, notifies us in writing of the defect, and delivers the product and/or defective part(s) freight prepaid to our factory or nearest authorized service station. THE SOLE AND EXCLUSIVE REMEDY FOR BREACH OF ANY AND ALL WARRANTIES WITH RESPECT TO ANY PRODUCT SHALL BE TO REPLACE OR REPAIR AT OUR ELECTION, F.O.B. POINT OF MANUFACTURE OR AUTHORIZED REPAIR STATION, SUCH PRODUCTS AND/OR PARTS REPAIR STATION, SUCH PRODUCTS AND/OR PARTS AS PROVEN DEFECTIVE. THERE SHALL BE NO FURTHER LIABILITY, WHETHER BASED ON WARRANTY, NEGLIGENCE OR OTHERWISE. Unless expressly stated otherwise guarantees in the nature of performance specifications furnished in addition to the foregoing material and workmanship warranties on a product manufactured by us, if any, are subject to laboratory tests corrected for field performance. Any additional guarantees, in the nature of performance specifications must be in writing and such writing must be signed by our authorized representative. Due to inaccuracies in field testing if a conflict arises between the results of field testing conducted by or for user, and laboratory test corrected for field performance, the latter shall control. Components or accessories supplied by us but manufactured by others are warranted only to the extent of and by the terms and conditions of the original manufacturer's warranty. RECOMMENDATIONS FOR SPECIAL APPLICATIONS OR THOSE RESULTING FROM SYSTEMS ANALYSES AND EVALUATIONS WE CONDUCT WILL BE BASED ON OUR BEST AVAILABLE EXPERIENCE AND PUBLISHED INDUSTRY INFORMATION. SUCH RECOMMENDATIONS DO NOT CONSTITUTE A WARRANTY OF SATISFACTORY PERFORMANCE AND NO SUCH WARRANTY IS GIVEN. This warranty shall not apply when damage is caused by (A) improper installation, (B) improper voltage (C) lightning (D) sand or other abrasive material (E) scale or corrosion build-up due to excessive chemical content. Any modification of the original equipment will also void the warranty. We will not be responsible for loss, damage or labour cost due to interruption of service caused by defective parts. Neither will we accept charges incurred by others without our prior written approval. This warranty is void if our inspection reveals the product was in a manner inconsistent with normal industry practice and/or our specific recommendations.

The purchaser is responsible for communication of all necessary information regarding the application and use of the product. UNDER NO CIRCUMSTANCES WILL BE RESPONSIBLE FOR ANY OTHER DIRECT OR CONSEQUENTIAL DAMAGES, INCLUDING BUT NOT LIMITED TO LOST PROFITS, LOST INCOME, LABOUR CHARGES, DELAYS IN PRODUCTION, IDLE PRODUCTION, WHICH DAMAGES ARE CAUSED BY ANY DEFECTS IN MATERIAL AND/OR WORKMANSHIP AND/OR DAMAGE OR DELAYS IN SHIPMENT. THIS WARRANTY IS EXPRESSLY IN LIEU OF ANY OTHER EXPRESS OR IMPLIED WARRANTY, INCLUDING ANY WARRANTY OF MERCHANTABILITY OR FITNESS FOR A PARTICULAR PURPOSE. No rights extended under this warranty shall be assigned to any other person, whether by operation of law or otherwise, without our prior written approval. If any litigation is commenced between the parties hereto for the enforcement of any rights hereunder, the successful party in subject litigation shall be entitled to receive from the unsuccessful party all costs incurred in connection therewith, including a reasonable amount of attorney's fees. YOUR ACCEPTANCE OF ANY GOODS SUPPLIED BY US, OR ON OUR BEHALF, SHALL, WITHOUT LIMITATION CONSTITUTE ACCEPTANCE OF ALL TERMS AND CONDITIONS STATED ABOVE.

PROJECT: _____
CONTRACTOR: _____
ENGINEER: _____
DATE: _____





Terms and Conditions

Our acceptance of your order is expressly conditioned on the general terms and conditions set forth below and all terms stated on the face of this form. The contract shall not include any deviating or additional terms unless expressly agreed to in writing and signed by an officer of our company.

PRICES: All prices are subject to change without notice and all shipments will be invoiced at the price in effect at the time of shipment, except when otherwise agreed to in writing by our authorized representative. Published prices are for products of our standard design and construction and any item not covered by the most recent published price list must be referred to us for special pricing. Prices do not include freight. Weights shown in price lists are approximate shipping weights. The amount of any applicable present or future tax or other government charge upon the production, sale, shipment or use of goods ordered or sold is not in the price and will be added to billing unless you provide us with an appropriate exemption certificate.

QUOTATION: Prices quoted by us are valid for 30 days from date of quotation unless we have otherwise specified in writing. Clerical errors on quotations are subject to our correction and such errors will not be binding.

CANCELLATION & REVISIONS: No purchase orders accepted and acknowledged by us may be cancelled or revised by you except with our prior written consent and upon payment of reasonable cancellation charges compensating us for all costs incurred in work done and material purchased. We reserve the right to determine what constitutes reasonable cancellation charges.

RETURN OF EQUIPMENT: No equipment shall be returned to us without first obtaining a written Returned Goods Authorization and shipping instruction from us. The returner must prepay the charges in full for transportation to our factory. Credit allowed for new, undamaged equipment of current standard design will be 80% of the invoiced price or current billing price, whichever is less. Equipment which has been used, however slight, will not be accepted. Authorization will not be given for return of equipment, (1) which would, in our opinion, result in an excess in the amount of stock we normally carry, (2) not invoiced within the last 3 months, or (3) which is non-standard and manufactured specifically to a buyer's specifications. For non-standard equipment not of our manufacture, the only credit allowed will be such credit as may be allowed by the manufacturer of such equipment. Equipment must be returned within 30 days of the issuance of the Returned Goods Authorization. No item with a net value of less than \$50.00 will be authorized for return. Unauthorized returns may be refused and/or returned freight collect.

CREDIT & PAYMENT: Payment is due as noted on our invoice. Overdue accounts are subject to a service charge. All orders are subject to approval of our credit department and we may require full or partial payment in advance. Pro rata payments shall become due as shipments are made. If the shipments are delayed by you for any cause, payments shall become due from date on which we are prepared to make shipment and storage shall be at your risk and expense. If manufacture is delayed by you for any

cause, a partial payment based upon the proportion of the order completed shall become due from the date on which we are notified of the delay.

SECURITY INTEREST: We shall have a lien on all goods sold as security for payment on the invoice price, and upon request you shall provide and execute a financing statement showing such lien.

DELIVERY: We will reasonable effort to meet your delivery requirement provided you provide us, on a timely basis, all approvals, technical data, instructions and credit approval requirements needed for release of the shipment. However, all delivery and/or shipment dates are estimates only unless we have expressly guaranteed delivery of such dates in writing at your specific request. In no event shall we have any liability if delivery is delayed by strikes, labour disturbances, material shortages, plant calamities or disaster, acts of God, government actions, civil disturbance, the failure of any pre-supposed condition of the contract, withholding shipments due to credit clearance, or other interferences beyond our reasonable control, and the date of delivery shall be extended for a period of time equal to the time lost because of any such reason.

SHIPPING: Unless you specify in writing and we acknowledge in writing, (A) goods will be boxed or crated as we may deem proper for protection against normal handling and for domestic shipment, (B) routing and manner of shipment will be at our discretion, and may be insured at your expense. An extra charge will be made for special handling. All shipments are F.O.B. point of manufacture. Delivery of goods to the initial carrier will constitute delivery to you and all goods will be shipped at your risk. A claim for loss or damage in transit must be entered with the carrier and prosecuted by you. Acceptance of material from a common carrier constitutes a waiver of any claims against us for delay, damage or loss.

GOVERNING LAW: It is understood and agreed that these Terms and Condition of Sale shall be interpreted under and pursuant to the laws of the Province of Quebec; you agree that any action at law which is related to any contract of sale brought against the company shall be filed in the appropriate court located in the Province of Quebec.

PROJECT: _____
CONTRACTOR: _____
ENGINEER: _____
DATE: _____



We are proud supplier for the following completed and on going projects :



Bethware Elementary High School
115 Bethware Dr, Kings Mountain, NC, United States



Old Montreal College
255 Ontario Est
Montreal, Quebec, CA



Ratiopharm Inc.
17800 Rue Lapointe,
Mirabel, QC, CA



Campus 99
5151 Côte-Ste-Catherine
Road, Montréal, QC, CA

Sales and Service:

Quebec, Canada
Tel. : (450) 621-2995
Fax : (450) 621-4995

Lake Worth
Florida, USA
33467-5749

Toronto, Canada
Tel. : +1 (647) 544-2995

www.flofab.com

SERVICE 24/7 : parts@flofab.com

