



## Operation Manual



# Contents

Installation and connection .....	1-6
Start-up, operation and maintenance .....	7-8
Assemble and disassemble .....	9
Fault finding and solution chart .....	10
Important notice .....	12



## I Installation and connection

### 1.Handing

When lifting the entire pump with motor, follow these instructions:

- Pump with motor sizes 0.37-7.5kW:  
Lift the pump in the motor flange by means of straps or the like.
- Pump with motor sizes 11-75kW:  
Lift the pump by means of the motor eyebolts.

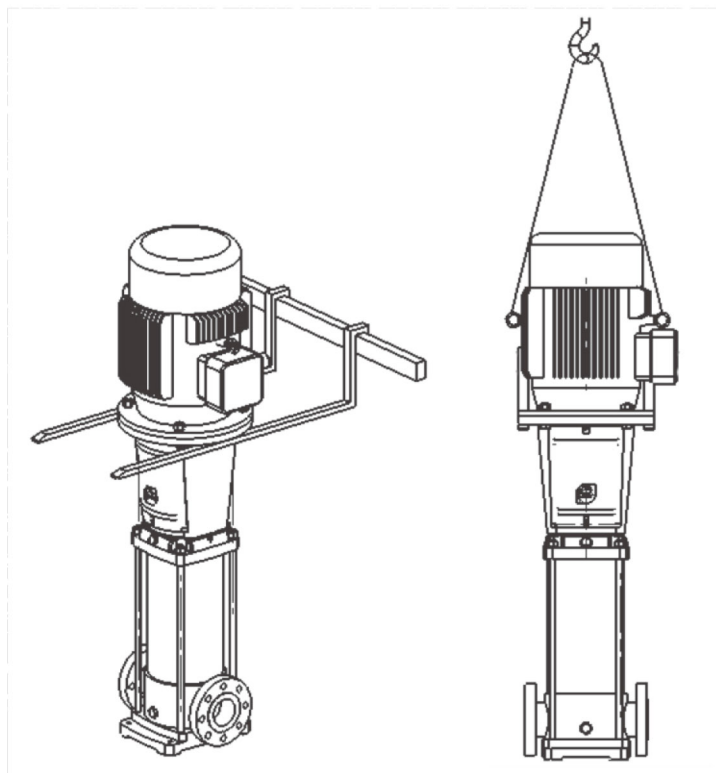

0.37-7.5kW

11-75kW

Size		Model															
		1	2	3	4	8	12	16	20	32	42	65	85	120	150	200	
Round flange connecting	DN	25		32	40	50			65	80	100		125		150		200
	P1	60			80				107	120	150		175		203		
	P	85		100	110	125			145	160	180		220		250		
	P2	115		140	150	165			185	200	220		270		300		
	n-d1	4-φ 14			4-φ 18				8-φ 18			8-φ 28					
	C	250			280	300			320	365	380		380		490		
	E	75		80	90			105	140			180		200			
	h	32		25	35			30	45			40		40			
	Nominal pressure	PN25							PN25-40		PN16		PN25-40				
Cutting Ferrule Joint connecting	D	42			60												
	C	210			260												
	E	50		80	90												
	h	20		25	35												
Pipe thread connection.	D	ZG1 $\frac{1}{4}$			ZG2												
	C	210			260												
	E	50		80	90												
	h	20		25	35												
Oval flange connection	D	G1		G $\frac{1}{4}$	G1 $\frac{1}{2}$												
	C	162			200												
	E	50		80													
	h	20		25													
	P	75		100													
	n-d1	2-M10× 40			2-M12× 45												
	k	22															
Footer size	G	100			130			170	190	199	275		385				
	G1	150			199			225	245	255	340		460				
	M	180			215			240	266	280	380		500				
	M1	210			247			298	330	348	472		600				
	d2	13			14							18		20			

The pump should be sited in a well ventilated and frost-free position. The distance between pump-motor and other objects should be at least 150mm , in order to cool the motor by fan with enough air.

- To reduce the head loss of inlet as least as possible, the inlet pipe shall be as short as possible.

- Ensure the check valve is installed in pipe line system before the pump installation. If pump is used for boiler water supply, a check valve must be installed in the piping between pump and boiler.

- Pump shall be installed in cement base or other similar base with suitable height. It can also be installed in fixed grounds or fixed brackets on wall. Pay attention not to let the weight of pipe system on pump to prevent pump from damage.

Caution: When installation, motor is not allowed to be hung upside down.

- Arrow on the inlet and outlet chamber shows the direction of flow of liquid through the pump. Check whether the liquid can flow easily before starting pump.

- Before pump installation, the inlet pipe line shall be cleaned. If there is impurities in the pipe, it is necessary to install a strainer at 0.5-1m in front of the pump inlet (particularly recommended for pump with flow less than  $8\text{m}^3/\text{h}$ ).

The air locks shall be avoided when installing the inlet pipe line. see Fig. 3

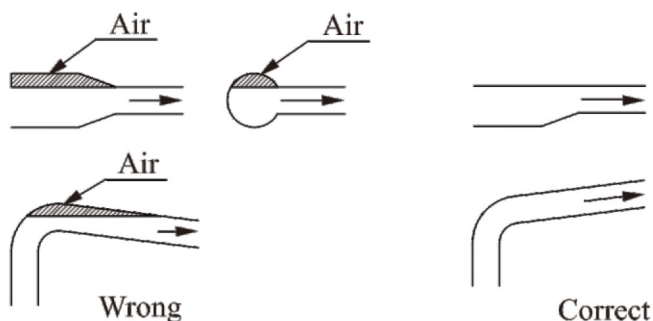

- If the outlet globe valve might be closed(or the flow is decreased to be zero), a bypass shall be installed in outlet pipeline to ensure adequate lubricating and cooling water to pass the pump.

## 2. Electrical connection

- The electrical connections should be carried out by an authorized electrician.

- To make sure the motor is suitable for the power supply, cables of the motor must be connected to power supply according to the Fig. on the terminal box and the motor nameplate.

- Motor shall be connected with a fast and effective motor starter, to ensure that the motor will not be damaged by lack of phase, unstable voltage or overload. The motor shall be earthed reliably.

Caution: Before take apart the terminal box cover or dismantle pump, make sure that the power supply is switched off.

## **Start-up, operation and maintenance**

Caution: Read the label on the cylinder carefully before start-up.

1. Do not start the pump until it has been filled with water or liquid fully.

- Fill water in pump in inverse pouring system.

Close the pump outlet valve, release air vent screw on the pump head, and open the inlet valve slowly until stable water flows from the air vent screw. Then fasten the screw. Open the check valve completely in the inlet pipeline.

· In open system, fill water in pump when liquid surface is lower than pump.

Notice: A check valve shall be installed in the inlet pipe.

Close the pump outlet valve, release air vent screw and fill the liquid in pump through the air vent screw hole until the pump and inlet pipe line are filled with water fully. Fasten the air vent screw again.

Caution: Do not start the pump until it has been filled with liquid fully and air vented. Be careful the direction of the air vent screw hole. Make sure the flowing water will not hurt persons or pump or its parts. Especially, prevent from hurting for the hot water application.

2. Check the rotary direction

Switch on the power supply and view the rotary direction by viewing the motor fan. Arrow on the pump head indicates the correct direction of rotation. That is, from the motor end, pump shall run counter-clockwise.

3. Check before pump start-up

- Check whether the foundation bolt is fasten.
- Check whether pump is filled with water fully.
- Check whether the voltage of power supply is correct.
- Check whether it turns correctly.
- To make sure all pipe lines are connected tightly and can supply water normally.

· The valves in the inlet pipe line are completely opened and the outlet valve shall be opened slowly after the pump is started up.

- Check the operation pressure if pressure meter is installed.

· Check all the controls for normal operation. If the pump is controlled by pressure switch, check and adjust the starting pressure and stopping pressure. Check the full load current to make sure it not surpasses the max. Current.

4. Frequency of pump starts

Pump should not be started too frequently. It is suggested pump shall not be started more than 100 times per hour if the motor power is less or equal to 4kW. When motor power is big than 4kW, pump shall not be sta-

rted more than 20 times in one hour. If pump starts and stops too frequently, control device shall be checked and adjusted to make pump not start and stop too frequently. Also, it is necessary to check the installation.

5.Suggestion: When pump running, flow should be controlled at the range of 0.5-1.3 times of rated flow.

6.Pump which is installed according to this installation manual will work effectively and require a little maintenance.

- Mechanical seal will be adjusted automatically, the moving part and stationary part is lubricated and cooled by the transferring liquid. When replace the mechanical seal, the user needn't to disassemble the motor for power bigger than 7.5kW.

- The bearing in pump is lubricated by the transferring liquid.

#### 7.Frost Protecting

Pump can be used in the system with anti-frozen measures to water. If the pump is installed in easily frozen place, suitable antifreeze shall be added to the transferring liquid to prevent pump from being damaged. If antifreeze is not used, pump shall be stopped when it is frozen. Pumps which are not being used should be drained.

8.The following should be checked regularly for pump.

- Pump working and operating pressure
- Possible leakage
- Possible motor overheat
- Cleaning/replacement of all strainers
- The switch off time of motor when overload
- Frequency of starts and stops.
- All control operation

If malfunction is found, check system according to “Fault finding and solution chart”

9.Pump shall be cleaned and kept appropriately when it is not used for a long time.

10.Pump shall be prevented from being corrupted and damaged in storage.



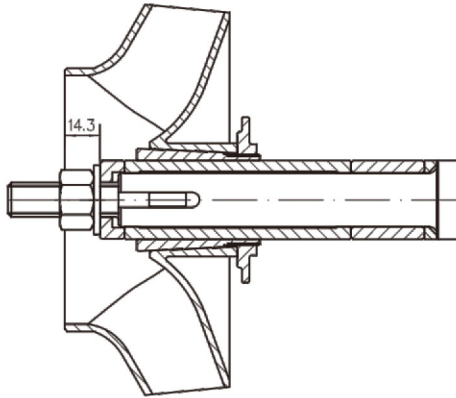

- Put the shaft parts on the inducer, fit support diffuser, impeller sleeve, impeller, fasten impeller nut, then, fit diffuser, impeller, etc. till the last diffuser.

- Fit the top diffuser, use straps to fasten all diffusers. Fit O-ring on the inlet and outlet chamber, lubricate them and put on cylinder.

- Fit stay bolts on the base plate, fit O-ring on the pump head, adjusting rubber, air vent screw, etc. Then put pump head on the stay bolts, fit washer, fasten nut.

- Fit the mechanical seal on the pump head, then fit the seal cover, tighten the bolts, and tighten the bolts in the seal. Lift the shaft and insert the adjusting slice.

- Fit the bracket and motor on the pump head. Finally fit the coupling, tighten the bolts, and take out the adjusting slice. Rotate the coupling to ensure that the shaft can rotate freely and not be choked and loose. Reverse the above process to disassemble a pump.

## Fault finding and solution chart

Caution: Before removing the terminal box cover and before any removal/dismantling of the pump, make sure that the power supply has been switched off.

Fault	Cause	Solution	Remarks
Motor does not run when started	a) Power supply failure.	a) Check power supply.	
	b) Fuses are blown.	b) Replace fuses.	
	c) Motor is overloaded.	c) Check system.	
	d) Main contacts of starter are not connected well or the coil is defective.	d) Replace motor starter.	
	e) Control circuit is defective.	e) Check control circuit.	
	f) Motor is defective.	f) Repair.	
Overload device of motor starter trips out immediately when power supply is switched on.	a) Fuses are blown.	a) Replace fuses.	In the case of d) and e), users shall not disassemble the pump by themselves.
	b) Contacts of overload device are faulty.	b) Check motor starter.	
	c) Cable connection is loose or faulty.	c) Check cables and power supply	
	d) Motor winding is defective.	d) Replace motor	
	e) Pump mechanically blocked.	e) Check and repair pump	
Overload device trips out occasionally.	a) The setting of overload is too low.	a) Reset overload setting	
	b) Periodic power supply faults.	b) Check power supply	
	c) Low voltage at peak times.	c) Add regulator.	
Motor starter has not tripped out but the pump does not run.	a) Contacts of starter are not contacted well or the coil is faulty.	a) Change motor starter	
	b) Control circuit are defective	b) Check control circuit	

Continued

Fault	Cause	Solution	Remarks
Pumped water does not flow constantly	a) Suction pipe is too small.	a) Enlarge inlet pipeline	
	b) There is not sufficient water in pump water inlet.	b) Improve system and increase coming water	
	c) Liquid level is low.	c) Try to lift liquid level.	
	d) Pump inlet pressure is too low compared with water temperature, pipeline loss and flow.	d) Improve system and try to increase the inlet pressure.	
	e) Suction pipe is partly blocked by impurities.	e) Check and clear impurities.	
Pump runs but gives no water.	a) Suction pipe is blocked by impurities.	a) Check and clean suction pipe.	
	b) Foot valve or check valve is closed.	b) Check and repair foot valve or check valve.	
	c) Leakage in suction pipe.	c) Check and repair suction pipe.	
	d) There is air in suction pipe or pump.	d) Refill liquid, release air.	
Pump runs backwards when switched off.	a) Leakage in suction pipe.	a) Check suction pipe	
	b) Foot valve or check valve is defective.	b) Check and repair foot valve or check valve.	
	c) Foot valve is blocked in opened or partly opened position.	c) Check and repair foot valve.	
	d) There is air in suction pipe.	d) Check and repair suction pipe and release air.	

Continued

Fault	Cause	Solution	Remarks
Abnormal vibration or noise from pump	a) Leakage in suction pipe.	a) Check and repair suction pipe.	In the case of e), users shall not disassemble the pump by themselves.
	b) Suction pipe is too small or suction pipe is partly blocked by impurities.	b) Enlarge or check suction pipe.	
	c) There is air in suction pipe or pump.	c) Refill liquid to the pump and vent air.	
	d) The comparison of the delivery head of device with delivery head of pump is very low.	d) Improve system or choose another pump model.	
	e) Pump mechanically blocked.	e) Check and repair pump.	

### Important notice

1. Customers will not be advised if this manual is updated.
2. Pump will be guaranteed for one year under normal operation with the correct model. Wearing part is not included.
3. Users shall be responsible for the damage if they disassemble the pumps by themselves in guaranteed period.