

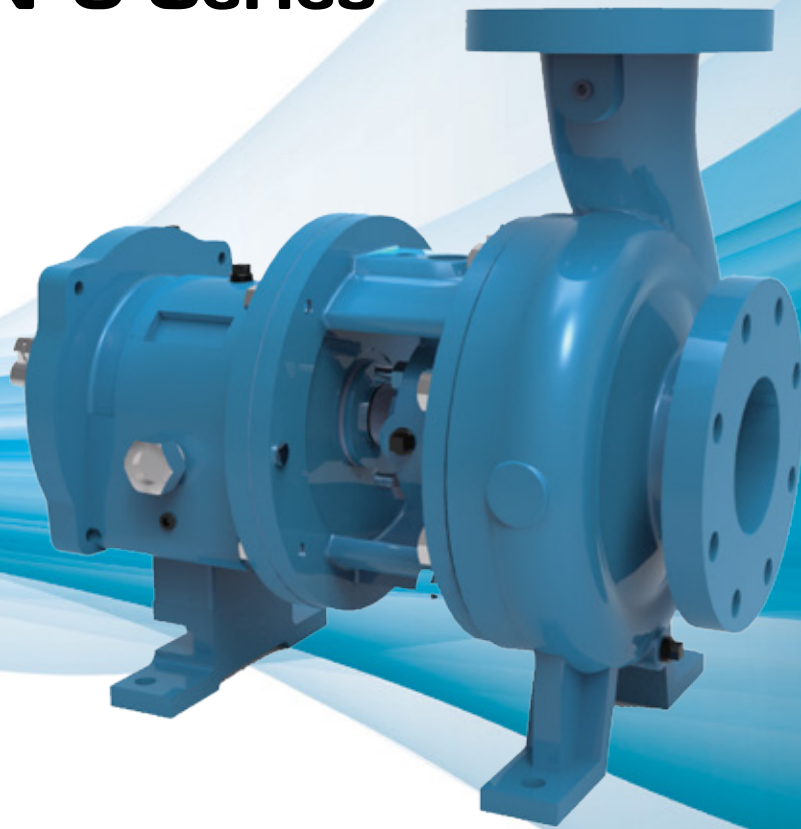

Chemical Process Pump

FFMCN-G Series



www.flofab.com

001-cat-2017-ffmcn-g

HISTORY

Flo Fab was established in 1981 by Denis Gauvreau who created and developed the products line and constantly being perfected by Marc Gauvreau, as well as by a team of professional engineers and designers. It's a combination of existing designs from several renowned products and the innovative ideas of a new generation professionals.

Through the years, Flo Fab has acquired several companies and service entities including : AQUA-PROFAB (ASME Tanks manufacturer), MÉNARD, LÉONARD ÉLECTRIQUE, PMA. , Furthermore Flo Fab purchased equipment, fabrication designs and patterns from IDEALCO, a manufacturer of shell and tube type heat exchangers.

The after sales services, sales, engineering, R&D, production, quality control, accounting and administration departments of all the above companies share the same location.

In December 2014, Marc Gauvreau, son of the founder, acquired all shares of The company. Flo Fab and is constantly investing in new state of the art innovations new product like the XRI series and Prefab Skid for Hydronic Heating & cooling system, pumping systems. This has allowed Flo Fab to retain competent and experienced staff of professionals with varied and specialized abilities that constantly work on improving our existing products and add new engineered solutions that exceeding customer's expectations .

Flo Fab has grown quite rapidly and now proudly offers of a wide range of products available directly from one manufacturer. This includes pumps & pump packages, tanks, heat exchangers & hydronic accessories. This allows each project stakeholders to enjoy economical savings, peace of mind, best value for their investment and optimized total cost of ownership.

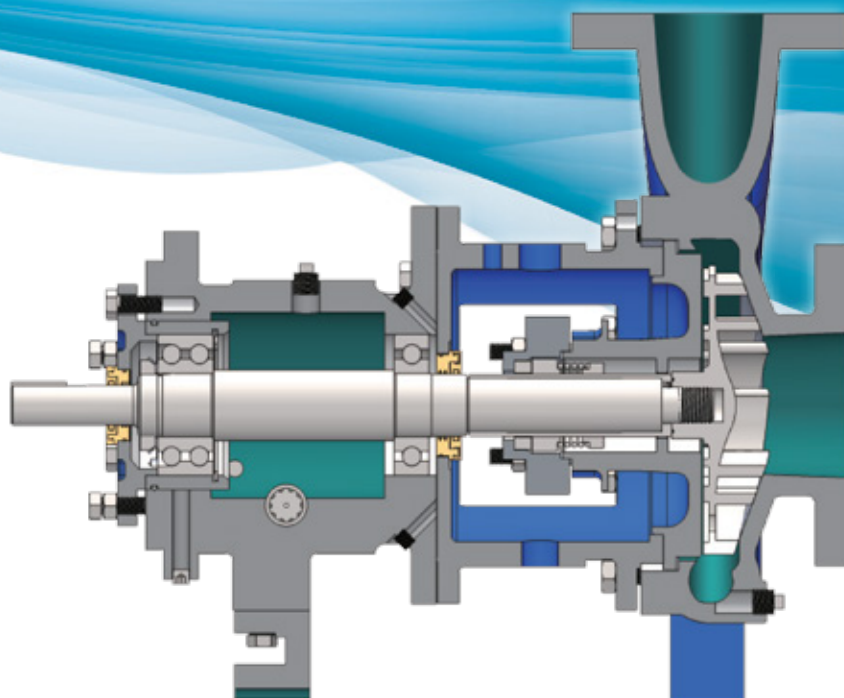

FFMCN-G

SECTIONAL VIEW

PRODUCT FEATURES

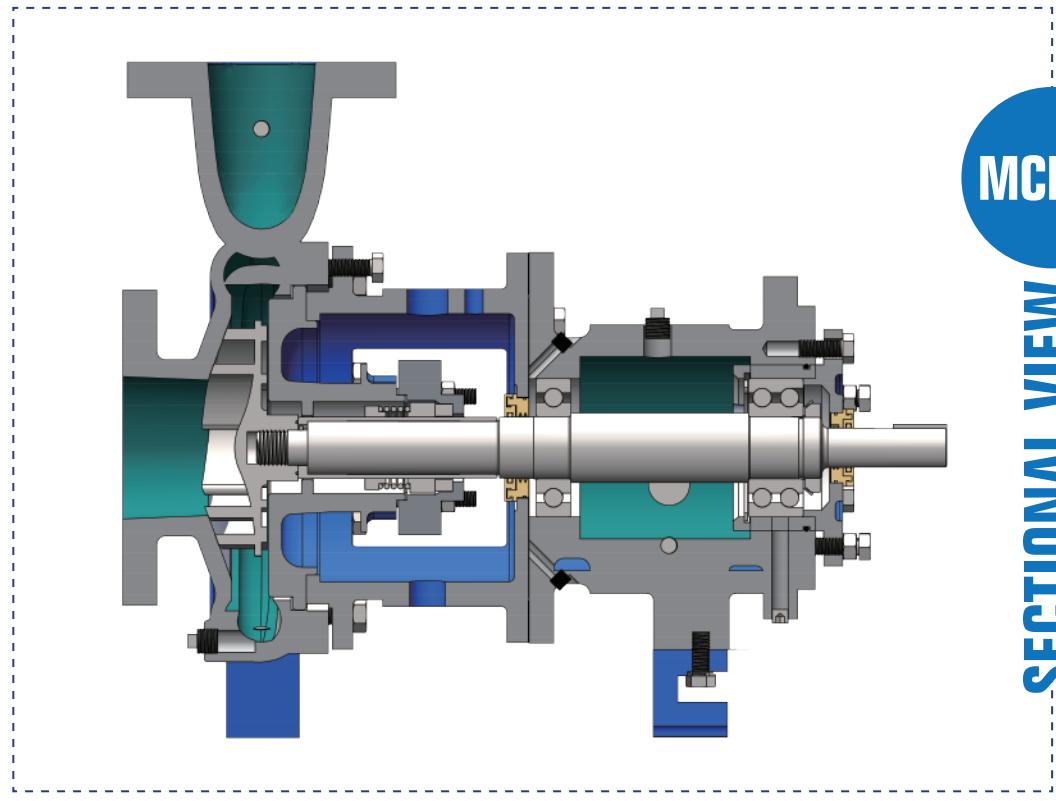

MCN-G

SECTIONAL VIEW

FloFab series chemical process pumps comply with ASME/ANSI B73.1M standard. With a maximum capacities of 7000GPM, maximum head of 730 feet, temperatures to 371°C and pressures to 375PSIG, this series pumps are designed for total range of industry services. Besides extended pump life, its' back pull-out design, external impeller adjustment and maximum interchangeability simplify the maintenance. Fully open impeller, full 50/60 Hz coverage and various sizes make hydraulic performance optimum. It is the best choice for chemical, petrochemical, pulp & paper, primary metals, food & beverage and general industries. Both bare shaft pump and pump package unit with base plate and motor are available. Various material constructions can be offered according to requirement.

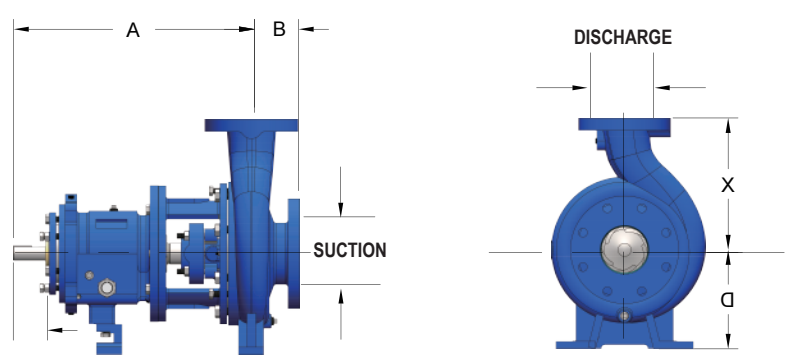

DIMENSIONS										
Group	Pump Size	ANSI Designation	Discharge Size	Suction Size	X	A	B	D	SP	Bare Pump Weight Lbs. (kg)
STN	1x1½-6	AA	1	1½	6.5 (165)	13.5 (343)	4 (102)	5.25 (133)	3.75 (95)	84 (38)
	1½x3-6	AB	1½	3						92 (42)
	2x3-6		2	3						95 (43)
	1x1½-8	AA	1	1½						100 (45)
MTN/ LTN	1½x3-8	AB	1½	3	19.5 (495)	4 (102)	8.25 (210)	3.75 (95)	108 (49)	
	3x4-7	A70	3	4					11 (280)	
	2x3-8	A60	2	3					9.5 (242)	
	3x4-8	A70	3	4					11 (280)	
	3x4-8G	A70	3	4					11 (280)	
	1x2-10	A05	1	2					8.5 (216)	
	1½x3-10	A50	1½	3					9.5 (242)	
	2x3-10	A60	2	3					9.5 (242)	
	3x4-10	A70	3	4					11 (280)	
	3x4-10H	A40	3	4					12.5 (318)	
	4x6-10	A80	4	6					13.5 (343)	
	4x6-10H	A80	4	6					13.5 (343)	
	1½x3-13	A20	1½	3					10.5 (267)	
	2x3-13	A30	2	3					11.5 (292)	
	3x4-13	A40	3	4					12.5 (318)	
	4x6-13	A80	4	6					13.5 (343)	
XLT-N	6x8-13	A90	6	8	27.875 (708)	6 (152)	14.5 (368)	5.25 (133)	16 (406)	
	8x10-13	A100	8	10					18 (457)	
	6x8-15	A110	6	8					18 (457)	
	8x10-15	A120	8	10					19 (483)	
	8x10-15G	A120	8	10					19 (483)	
	8x10-16H	A120	8	10					19 (483)	
	4x6-17		4	6					16 (406)	
	6x8-17		6	8					18 (457)	
	8x10-17		8	10					19 (483)	

MODEL MCN(5196) INTERCHANGEABILITY & OUTLINE DIMENSION DRAWING

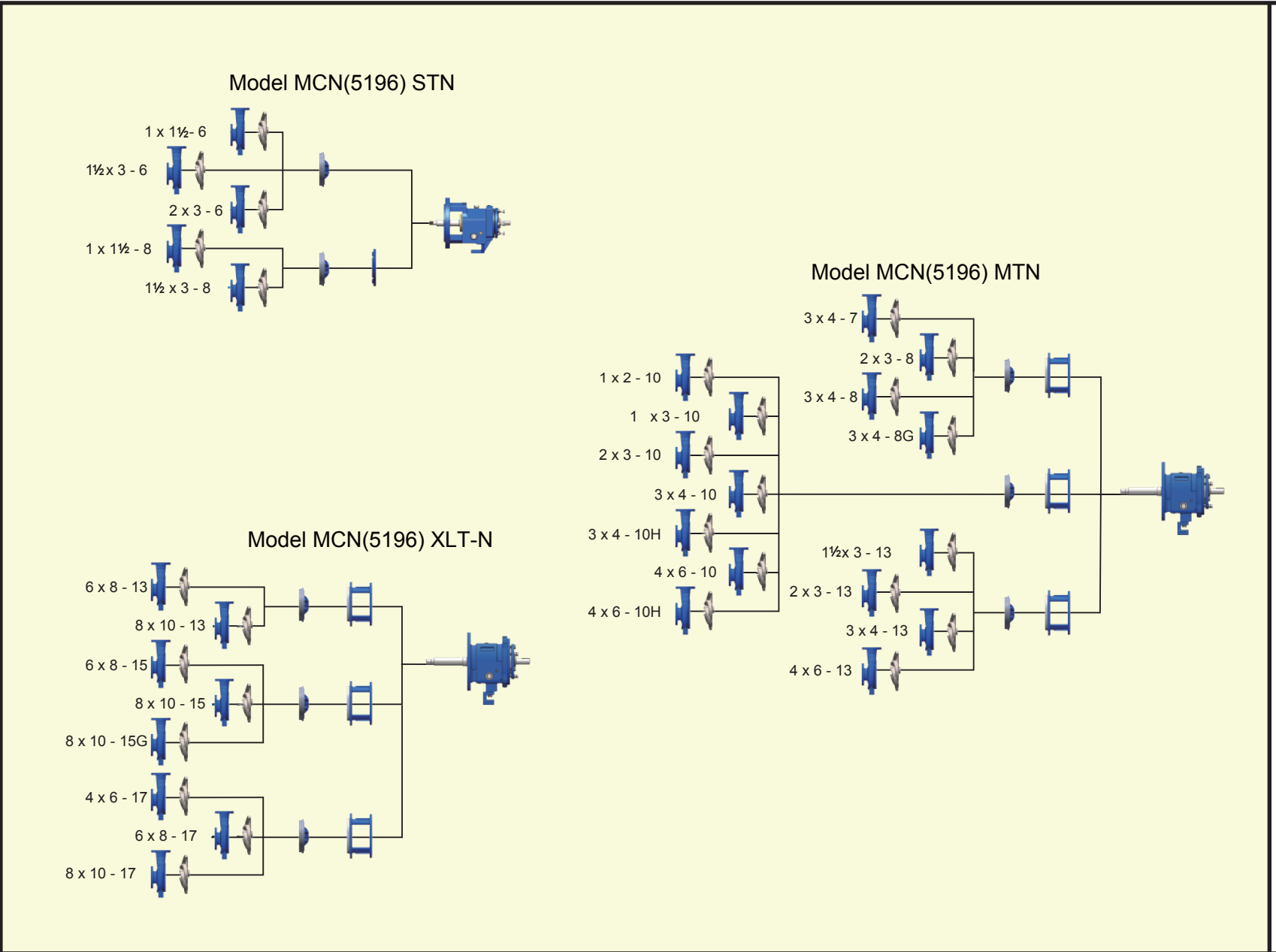



PERFORMANCE CHARTS

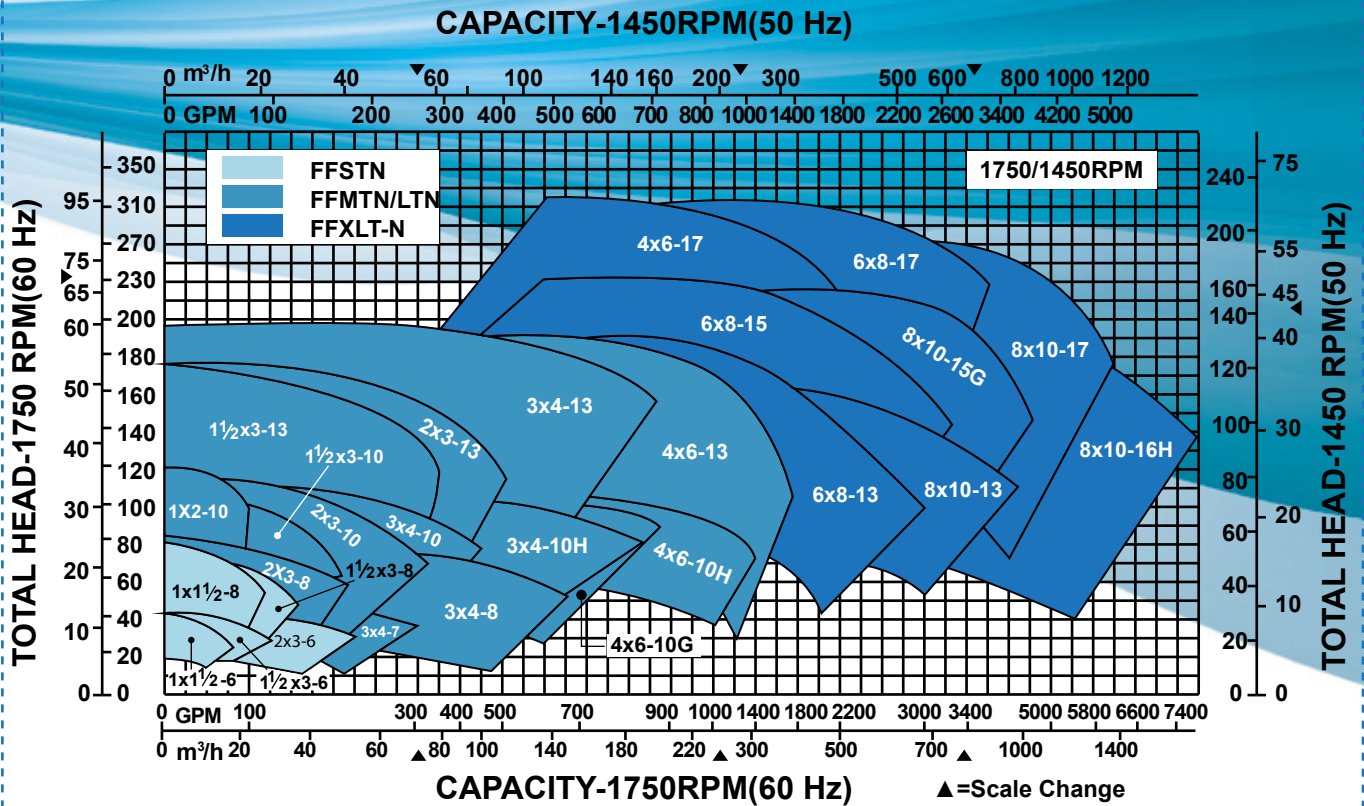
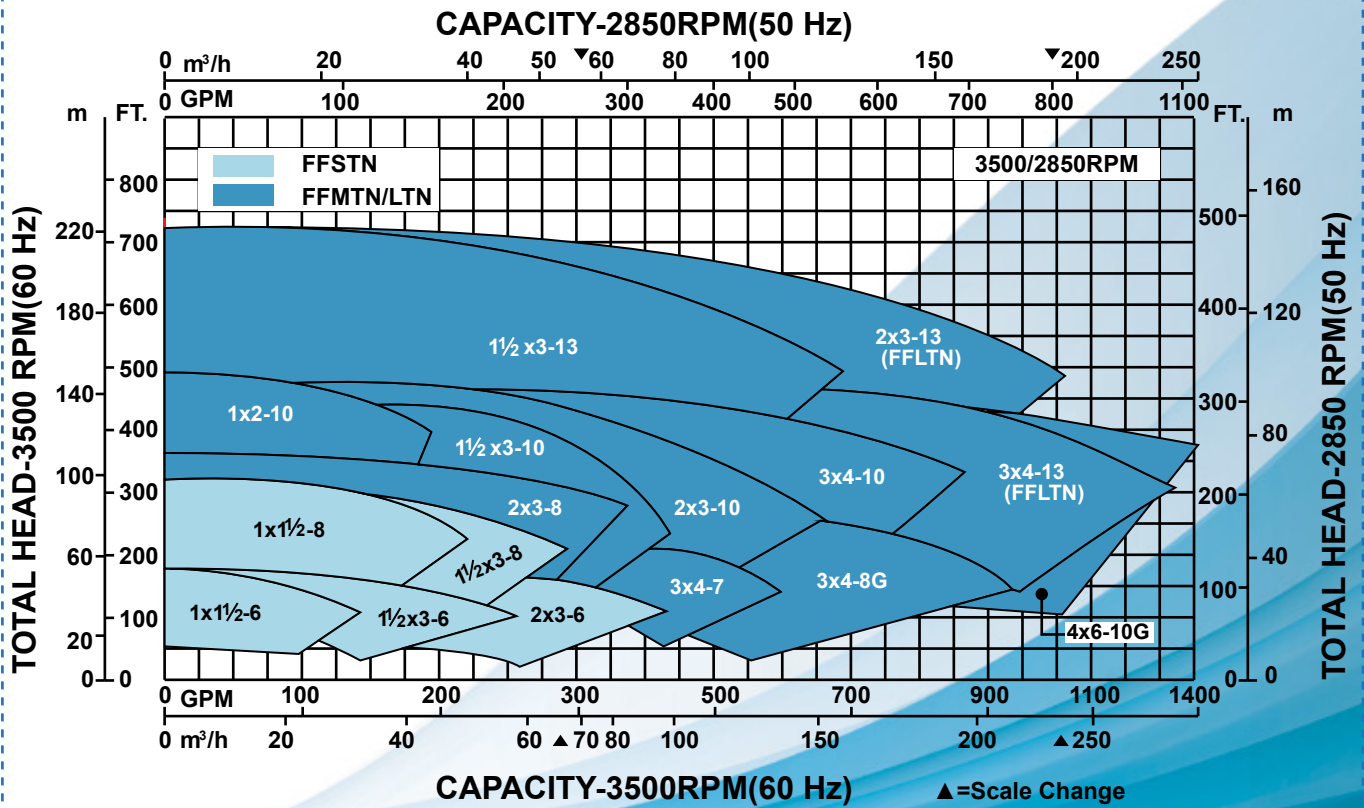

We are proud supplier for the following
completed and on going projects :



Western Power Sports
601 E Gowen Rd,
Boise, ID, USA



Granite Broadway
1717 Broadway, New York,
New York, USA



Yale University
New Haven,
Connecticut, USA

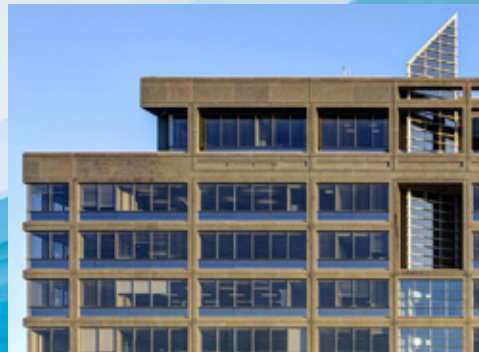

SSQ Building
2525 Laurier boulevard
Quebec City, QC, Canada

Sales and Service:

Quebec, Canada
Tel. : (450) 621-2995
Fax : (450) 621-4995

Lake Worth
Florida, USA
33467-5749

Toronto, Canada
Tel. : +1 (647) 544-2995

www.flofab.com

SERVICE 24/7 : parts@flofab.com

