



PSM

Light Vertical Multistage Centrifugal Pump

Operation Manual



CNP170405
Code1500039725
subject to amendments





Machinery Directive: 2006/42/EC

Electromagnetic Compatibility Directive: 2004/108/EC

Name of manufacturer or supplier

Flo Fab inc.

Ren he Town, Yuhang District, Hangzhou, Zhejiang, China.

Description of product

This product is a water-pumping machine, which is the type of non-self-priming vertical multistage centrifugal pumps, featured with high efficiency, low noise, light corrosive liquid bearable and compact structure.

This product is considered as a partly completed machine since there is no control device except a motor with terminal box.

Name, type or model, batch or serial number

Name: Light Vertical Multistage Centrifugal Pump

Model: PSM Series

Standards used, including number, title, issue date and other relative documents

EN ISO 12100-1:2003、 EN ISO 12100-2:2003+A1:2009、 EN 809:1998+AC:2009/AC:2010, EN 61000-6-2:2005、 EN 61000-6-4:2007.

Declaration

I declare that as the authorised representative, the above information in relation to the supply / manufacture of this product, is in conformity with the provisions of the above Directives based on elements of the above standards. The machinery is incomplete and must not be put into service until the machinery and control system into which it is to be incorporated has been declared in conformity with the provisions of the Directive.

Position: Fully quality management center
vice director

Signature :

Authorised Representative in EU
Name:

Address:

Date: 2013-02-28

Contents

I. Applications and conditions -----	1
II. Definition of model -----	4
III. Structure -----	5
IV. Installation and connection -----	15
V. Start-up, operation and maintenance -----	41
VI. Assemble and disassemble -----	43
VII. Fault finding and solution chart -----	46
VIII. Important notice -----	48

Read this manual carefully before installing, starting the pump

I. Applications and conditions

Pumps of PSM model are non-self-priming vertical multistage centrifugal pumps. The features are high efficient, low noise, low corrosion resistance, compact structure, good appearance, small volume, light weight, excellent maintainability good seal performance, etc.

1. Applications

· Pumped liquids: Low viscosity, neutral, non-explosive liquids, not containing solid particles or fibres. The liquid must not attack the pump materials chemically;

- Boiler water supply and condensing system;
- Water treatment, filtration system;
- Food and beverage industries;
- Pressure boosting in high-rise buildings;
- Farmland irrigation, nursery irrigation and golf court irrigation;
- Fire fighting system;
- Industry cleaning system;
- Liquid conveying, circulation and boosting;
- Hot and cold water;

2. Operation conditions

· Medium temperature: Normal temperature type $-15^{\circ}\text{C} \sim +70^{\circ}\text{C}$;
Hot water type $-15^{\circ}\text{C} \sim +120^{\circ}\text{C}$;

- Flow: $0.4 \sim 240\text{m}^3/\text{h}$;
- Medium pH range: pH 5-9;
- Maximum ambient temperature: $+40^{\circ}\text{C}$;
- Maximum altitude: 1000 m;
- Minimum inlet pressure: Refer to NPSH curve;
- Maximum working pressure refer to Fig.1A&1B;

Caution: When pumping liquids with a density and/or viscosity higher than that of water, use motors with correspondingly higher outputs, if required.

Fig.1A

50Hz

Model	Max. pressure(bar)
PSM1,2,3,4,5 Flange	25
PSM1,2,3,4,5 Oval Flange	16
PSM1,2,3,4,5 Flange、Cutting Ferrule、Pipe thread	25
PSM8,10,12,15,16,20 Flange	25
PSM8,10 Oval Flange	16
PSM8,10,12,15,16,20 Flange、Cutting Ferrule、Pipe thread	25
PSM32	
32-10-1~32-80	16
32-90-2~32-160	30
PSM32	30
PSM42	
42-10-1~42-60-2	16
42-60~42-90	25
42-100-2~42-130-2	30
PSM42	
42-10-1~42-90	25
42-100-2~42-130-2	30
PSM65	
65-10-1~65-50-2	16
65-50-1~65-80-1	25
PSM85	
85-10-1~85-40-2	16
85-40~85-60	25
PSM 65, 85	25
PSM120,150,200	20

Fig.1B

60Hz

Model	Max. pressure(bar)
PSM 1,2,3,4,5 Flange	25
PSM1,2,3,4,5 Oval Flange	16
PSM 1,2,3,4,5 Flange, cutting ferrule joint, pipe thread	25
PSM8,10,12,15,16,20Flange	25
PSM8,10 Oval Flange	16
PSM8,10,12,15,16,20Flange - cutting ferrule joint, pipe thread	25
PSM32	
32-10-1~32-60-2	16
32-60~32-100-2	30
PSM32	30
PSM42	
42-10-1~42-40-2	16
42-40~42-60	25
42-70-2~42-70	30
PSM42	
42-10-1~42-60	25
42-70-2~42-70	30
PSM65	
65-10-1~65-30	16
65-40-2~65-50-2	25
PSM85	
85-10-1~85-30-2	16
85-30-1~85-40-2	25
PSM 65,85	25
PSM 120,150,200	20

II. Definition of model

1. PSM1,2,3,4,5,8,10,12,15,16,20

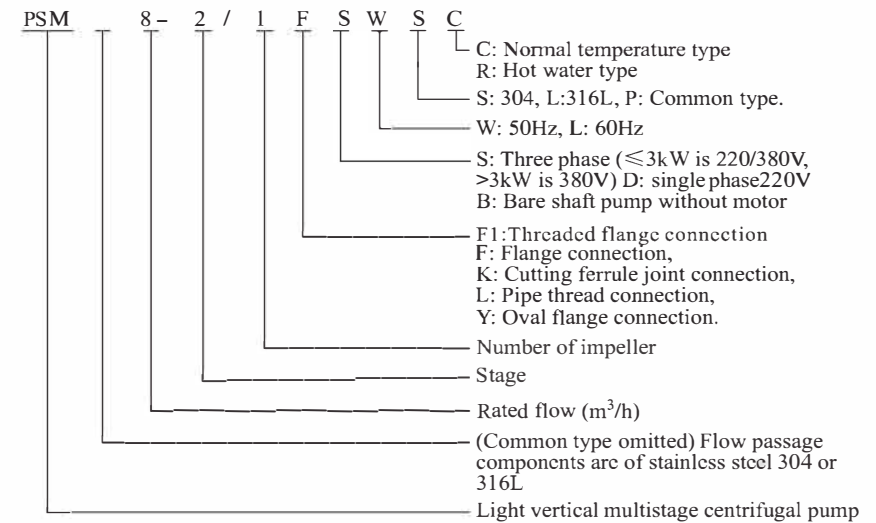

2. PSM 32,42,65,85,120,150

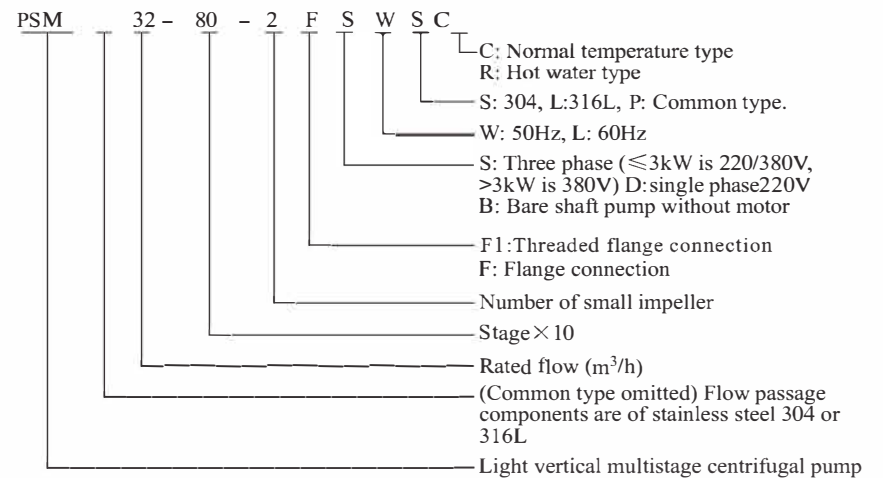

3. PSM 200

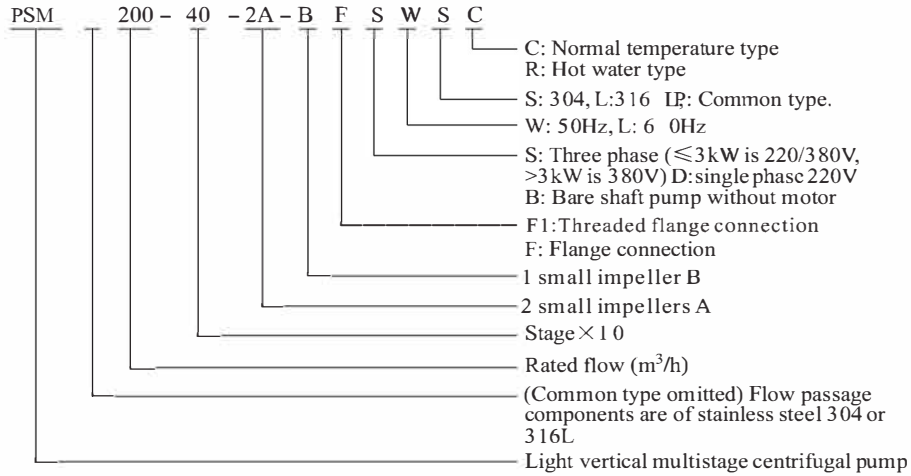

III. Structure

• The pump is mainly composed of motor, pump head, diffuser, impeller, cylinder, inlet & outlet chamber, pump shaft, mechanical seal and so on. Refer to fig.2;

• Key parts of the pump such as diffuser, impeller, cylinder, shaft, are all made of stainless steel. For PSM series, material of pump head and inlet & outlet chamber is made of cast iron. While for PSM series, they are made of stainless steel;

• Mechanical seal is single mechanical seal. Grinding block is cemented carbides/carbon. Support part of support diffuser is made of tungsten carbide;

• Normally pumps and pipes are connected by round flanges. Different types of connections are also available on demand of customer. Refer to fig.3

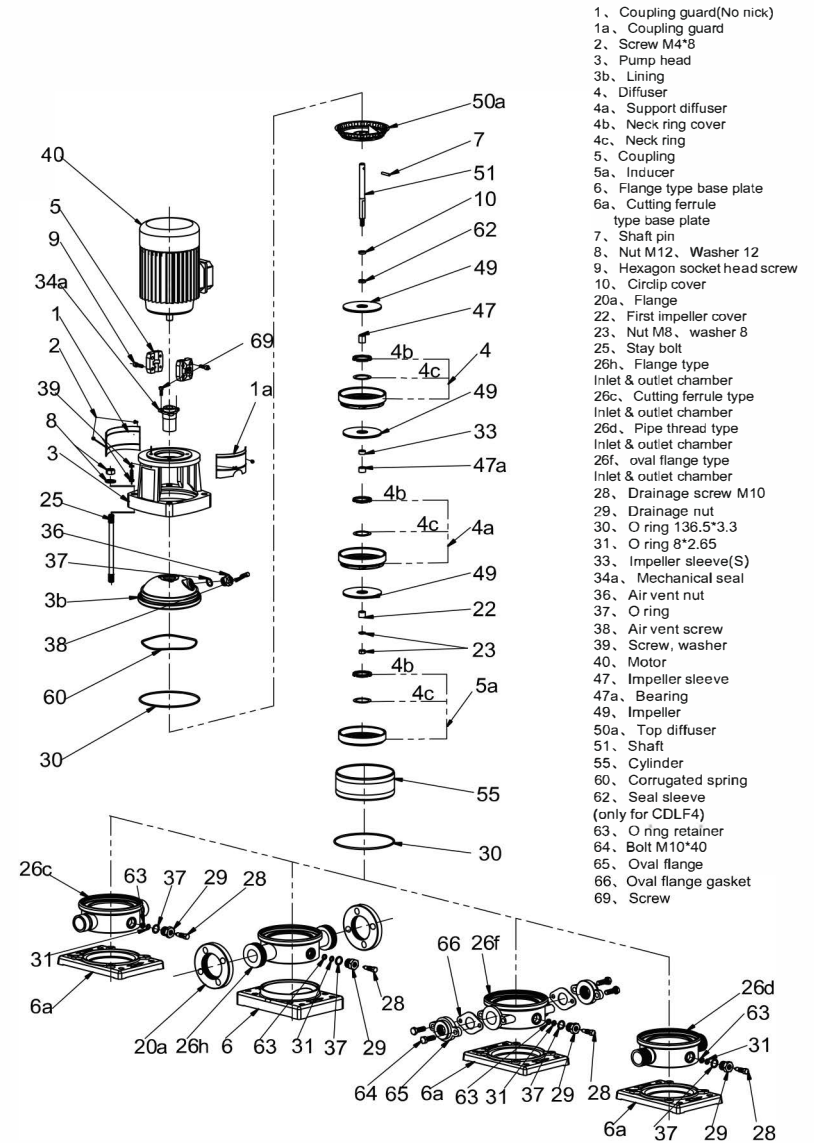

E-PSM1,2,3,4,5-111201

Figure 2A

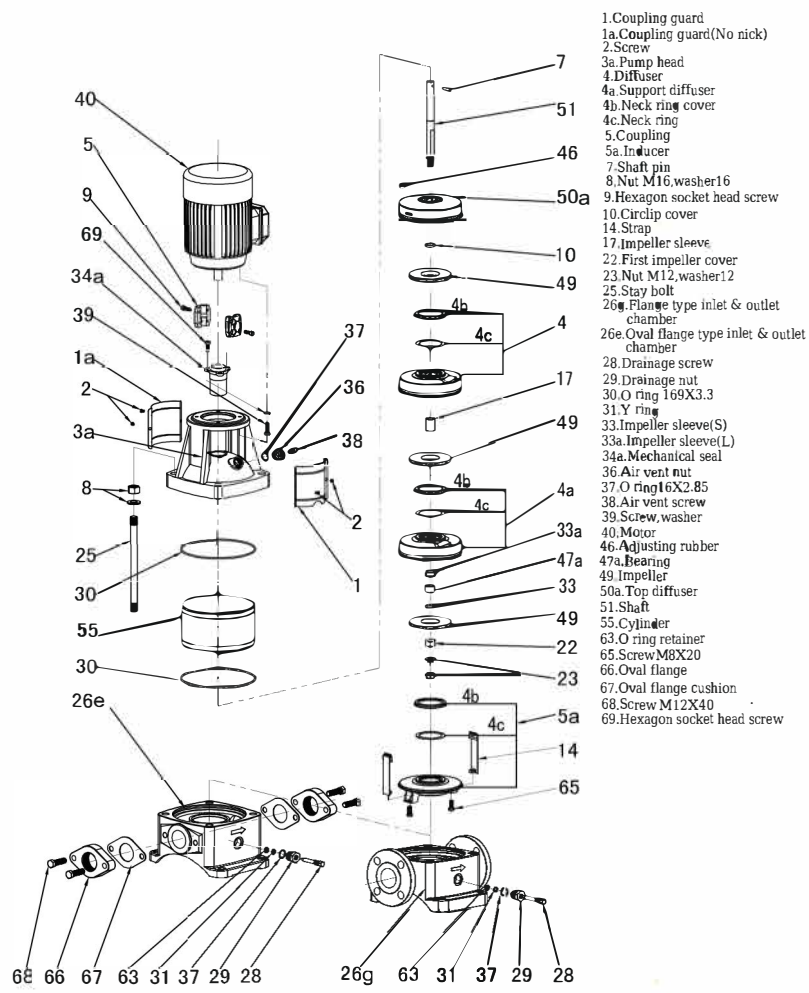

E-PSM8, 10-150601

Figure 2D

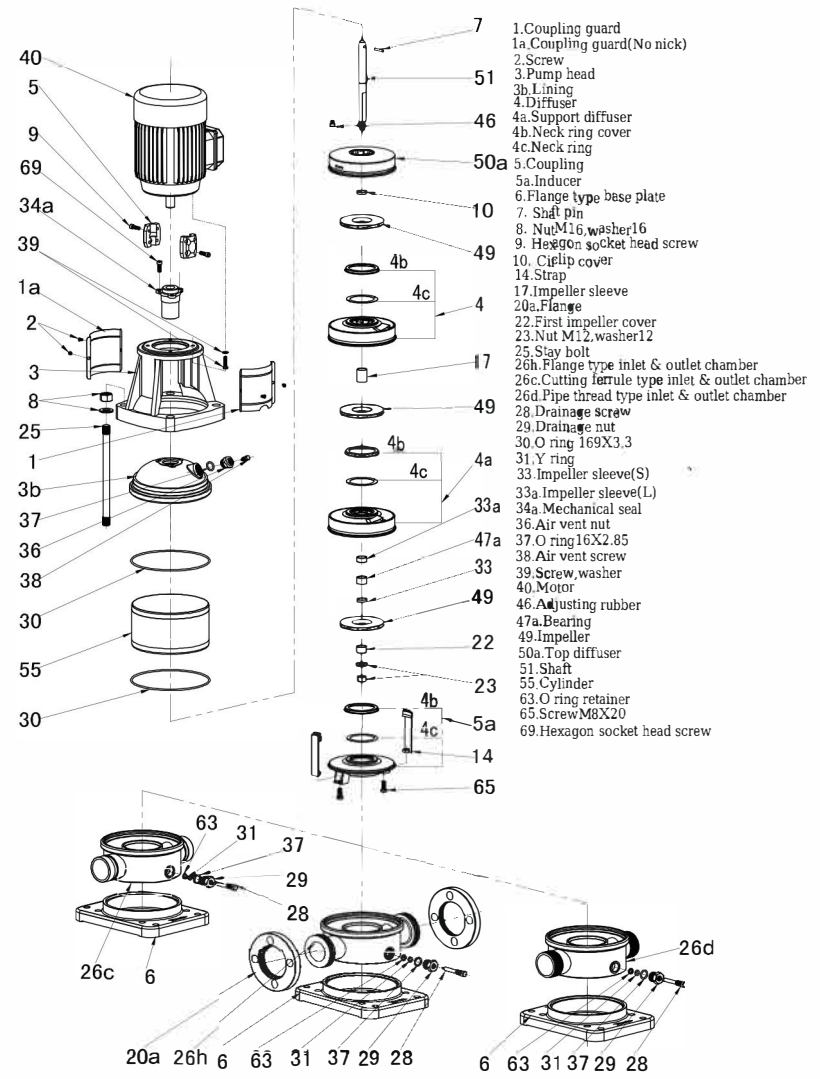

E-PSM12 , 15, 16, 20-150601

Figure 2E

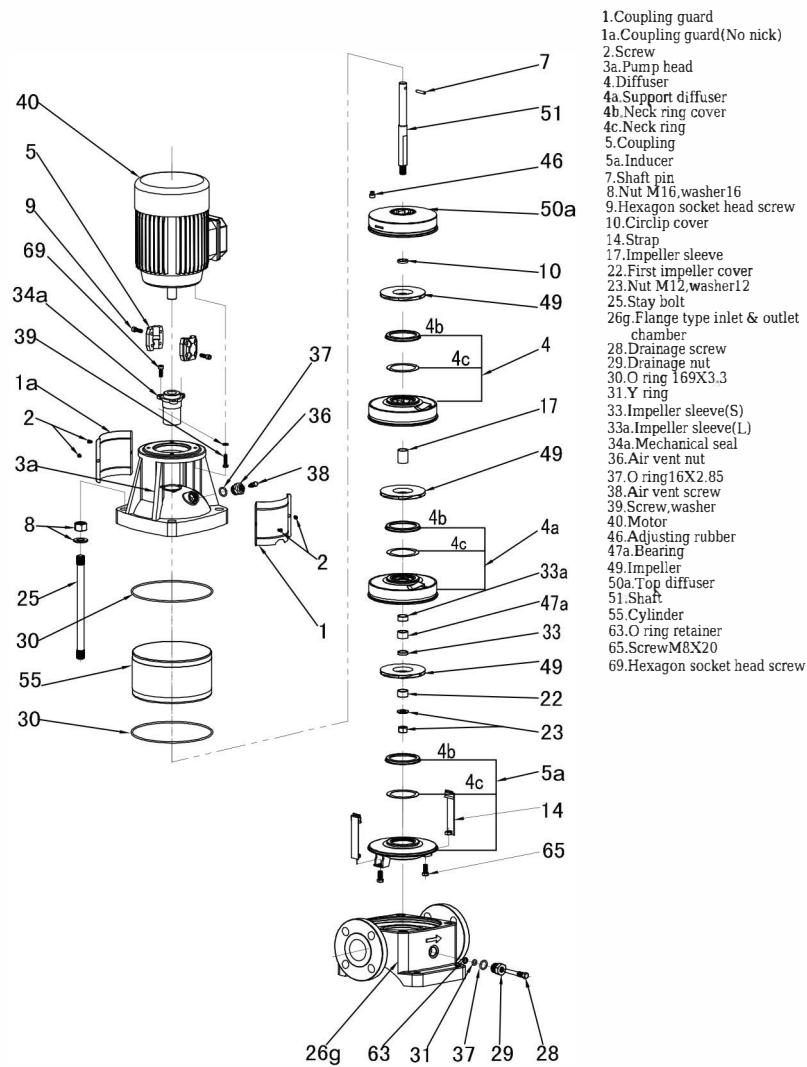

E-PSM12, 15, 16, 20-150601

Figure 2F

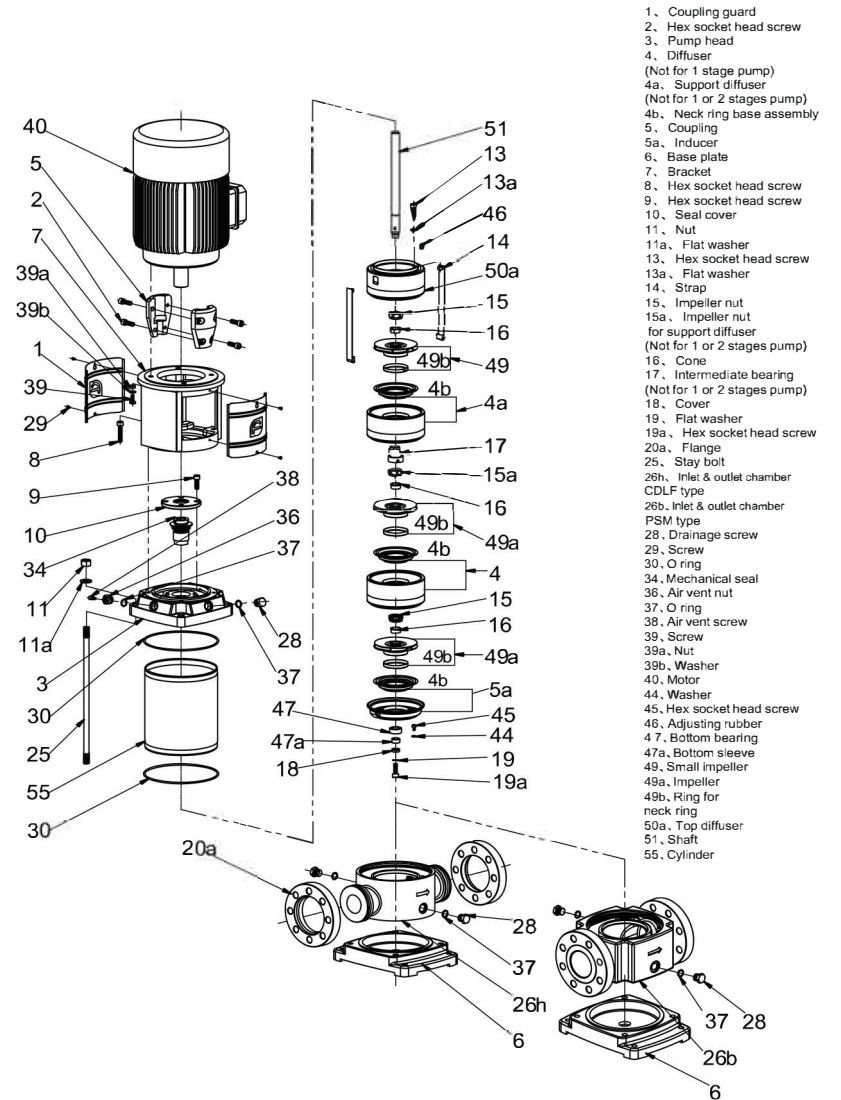

E-PSM32, 42, 65, 85-120702

Figure 2G

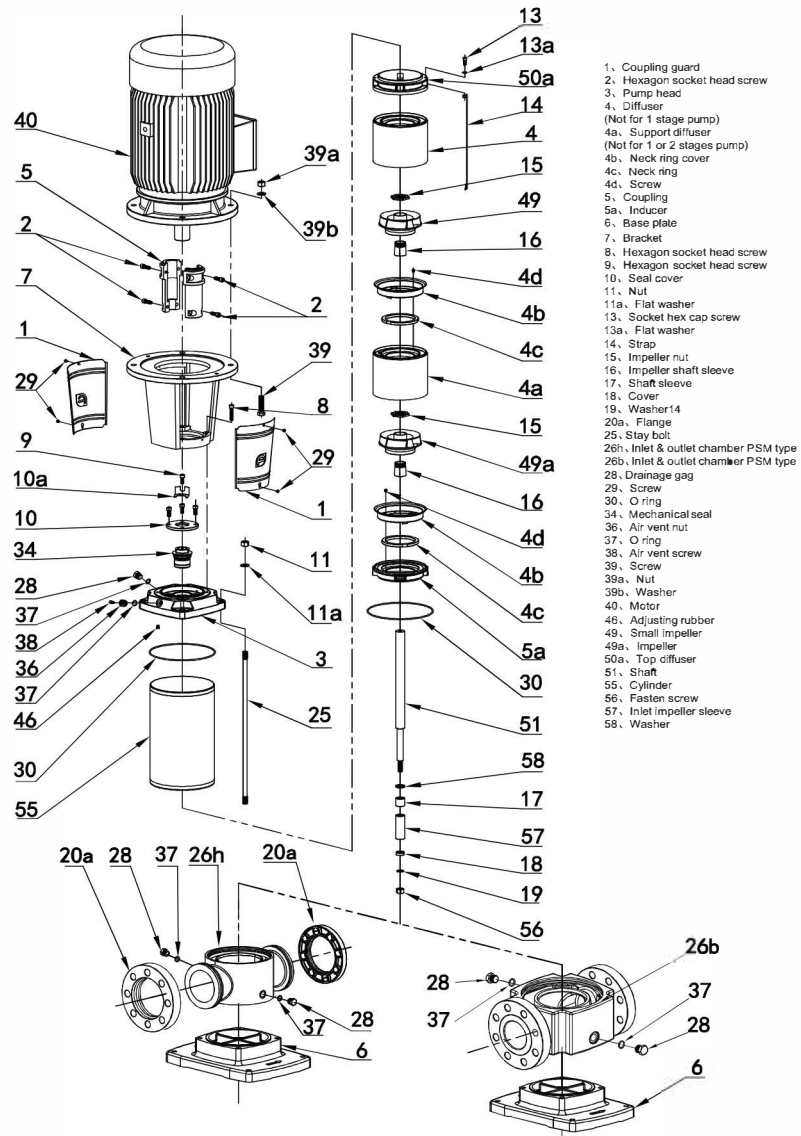

E-PSM120,150,200-160302

Figure 2H

2.Pump installation

Pump size and dimension is as below.

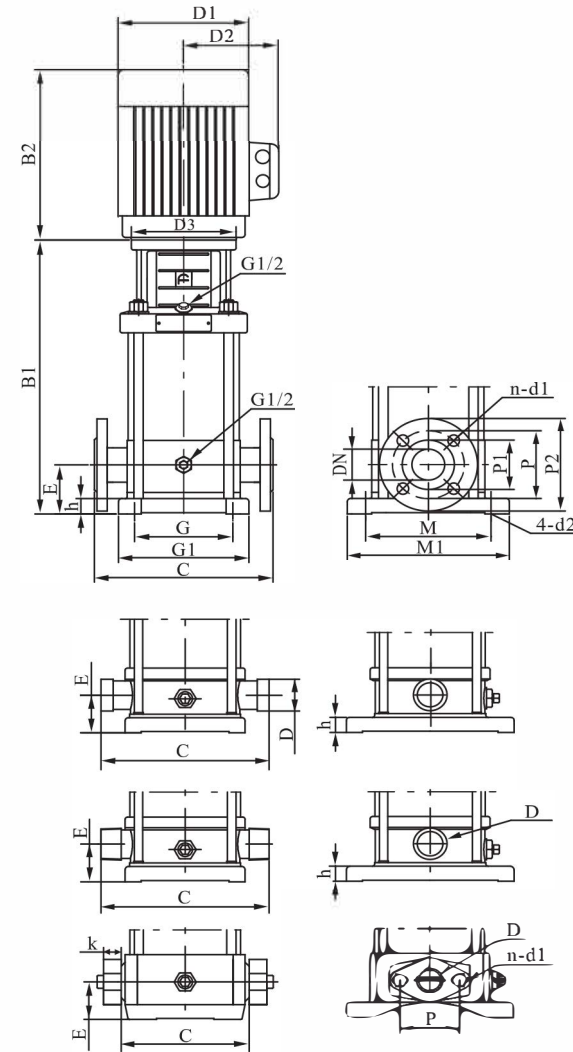

Figure 3 Installation sketch

IV. Installation and connection

1. Handing

When lifting the entire pump with motor, follow these instructions:

- Pump with motor sizes 0.37-7.5kW:
Lift the pump in the motor flange by means of straps or the like.
- Pump with motor sizes 11-110kW:
Lift the pump by means of the motor lifting eyes.

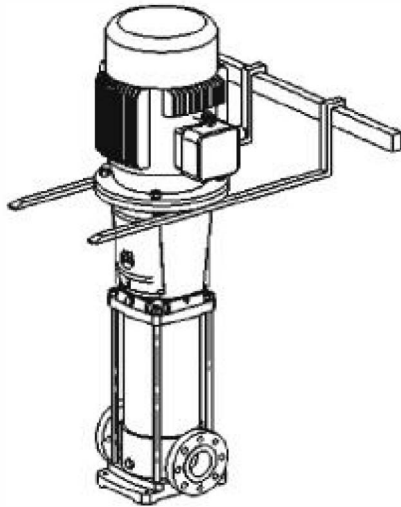

0.37-7.5kW

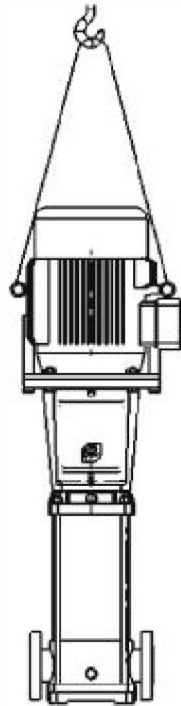

11-110kW

Table 1 Pump outline dimensions 50Hz

Model	Size (mm)						Weight (kg)
	B1	B2	B1+B2	D1	D2	D3	
PSM1-2	258	225	483	148	117	105	20
PSM1-3	276	225	501	148	117	105	20
PSM1-4	294	225	519	148	117	105	21
PSM1-5	312	225	537	148	117	105	21
PSM1-6	330	225	555	148	117	105	22
PSM1-7	348	225	573	148	117	105	23
PSM1-8	366	225	591	148	117	105	24
PSM1-9	384	225	609	148	117	105	25
PSM1-10	402	225	627	148	117	105	26
PSM1-11	420	225	645	148	117	105	26
PSM1-12	448	245	693	170	142	120	29
PSM1-13	466	245	711	170	142	120	30
PSM1-15	502	245	747	170	142	120	31
PSM1-17	538	245	783	170	142	120	33
PSM1-19	574	245	819	170	142	120	34
PSM1-21	610	245	855	170	142	120	35
PSM1-23	646	245	891	170	142	120	36
PSM1-25	692	290	982	190	155	140	42
PSM1-27	728	290	1018	190	155	140	43
PSM1-30	782	290	1072	190	155	140	45
PSM1-33	836	290	1126	190	155	140	49
PSM1-36	890	290	1180	190	155	140	51
PSM2-2	258	225	483	148	117	105	20
PSM2-3	276	225	501	148	117	105	20
PSM2-4	294	225	519	148	117	105	22
PSM2-5	312	225	537	148	117	105	23
PSM2-6	340	245	585	170	142	120	26
PSM2-7	358	245	603	170	142	120	26
PSM2-9	394	245	639	170	142	120	28
PSM2-11	430	245	675	170	142	120	29
PSM2-13	476	290	766	190	155	140	35
PSM2-15	512	290	802	190	155	140	36
PSM2-18	566	290	856	190	155	140	41
PSM2-22	638	290	928	190	155	140	42
PSM2-26	720	345	1065	197	165	160	52

Continued 50Hz

Model	Size (mm)						Weight (kg)
	B1	B2	B1+B2	D1	D2	D3	
PSM3-2	258	225	483	148	117	105	20
PSM3-3	276	225	501	148	117	105	20
PSM3-4	294	225	519	148	117	105	21
PSM3-5	312	225	537	148	117	105	21
PSM3-6	330	225	555	148	117	105	23
PSM3-7	348	225	573	148	117	105	24
PSM3-8	376	245	621	170	142	120	27
PSM3-9	394	245	639	170	142	120	28
PSM3-10	412	245	657	170	142	120	28
PSM3-11	430	245	675	170	142	120	29
PSM3-12	448	245	693	170	142	120	30
PSM3-13	466	245	711	170	142	120	31
PSM3-15	502	245	747	170	142	120	32
PSM3-17	548	290	838	190	155	140	38
PSM3-19	584	290	874	190	155	140	39
PSM3-21	620	290	910	190	155	140	42
PSM3-23	656	290	946	190	155	140	43
PSM3-25	692	290	982	190	155	140	44
PSM3-27	728	290	1018	190	155	140	45
PSM3-29	764	290	1054	190	155	140	46
PSM3-31	810	345	1155	197	165	160	54
PSM3-33	846	345	1191	197	165	160	55
PSM3-36	900	345	1245	197	165	160	57
PSM4-2	276	225	501	148	117	105	21
PSM4-3	303	225	528	148	117	105	22
PSM4-4	340	245	585	170	142	120	25
PSM4-5	367	245	612	170	142	120	27
PSM4-6	394	245	639	170	142	120	27
PSM4-7	431	290	721	190	155	140	33
PSM4-8	458	290	748	190	155	140	33
PSM4-10	512	290	802	190	155	140	37
PSM4-12	566	290	856	190	155	140	38
PSM4-14	630	345	975	197	165	140	46
PSM4-16	684	345	1029	197	165	140	48
PSM4-19	765	355	1120	230	188	160	57
PSM4-22	846	355	1201	230	188	160	59

Continued 50Hz

Model	Size (mm)						Weight (kg)
	B1	B2	B1+B2	D1	D2	D3	
PSM5-2	276	225	501	148	117	105	26
PSM5-3	303	225	528	148	117	105	27
PSM5-4	330	225	555	148	117	105	27
PSM5-5	367	245	612	170	142	120	28
PSM5-6	394	245	639	170	142	120	29
PSM5-7	421	245	666	170	142	120	29
PSM5-8	448	245	693	170	142	120	30
PSM5-9	485	290	775	190	155	140	35
PSM5-10	512	290	802	190	155	140	36
PSM5-11	539	290	829	190	155	140	40
PSM5-12	566	290	856	190	155	140	41
PSM5-13	593	290	883	190	155	140	41
PSM5-14	620	290	910	190	155	140	42
PSM5-15	647	290	937	190	155	140	42
PSM5-16	684	290	974	190	155	140	43
PSM5-18	738	345	1083	197	165	160	50
PSM5-20	782	345	1127	197	165	160	51
PSM5-22	846	355	1201	230	188	160	59
PSM5-24	900	355	1255	230	188	160	60
PSM5-26	954	355	1309	230	188	160	61
PSM5-29	1035	355	1390	230	188	160	63
PSM5-32	1136	390	1526	260	208	200	85
PSM5-36	1244	390	1634	260	208	200	87
PSM8-2/1	347	245	592	170	142	120	32
PSM8-2	347	245	592	170	142	120	32
PSM8-3	377	245	622	170	142	120	34
PSM8-4	417	290	707	190	155	140	40
PSM8-5	447	290	737	190	155	140	44
PSM8-6	477	290	767	190	155	140	45
PSM8-8	547	345	892	197	165	160	53
PSM8-10	607	355	962	230	188	160	64
PSM8-12	667	355	1022	230	188	160	66
PSM8-14	747	390	1137	260	208	200	81
PSM8-16	807	390	1197	260	208	200	84
PSM8-18	867	390	1257	260	208	200	93
PSM8-20	927	390	1317	260	208	200	94

Continued 50Hz

Model	Size (mm)						Weight (kg)
	B1	B2	B1+B2	D1	D2	D3	
PSM10-1	347	245	592	170	142	120	40
PSM10-2	347	245	592	170	142		41
PSM10-3	377	245	622	170	142		43
PSM10-4	417	290	707	190	155	140	49
PSM10-5	447	290	737	190	155		53
PSM10-6	477	290	767	190	155		54
PSM10-7	517	345	862	197	165	160	64
PSM10-8	547	345	892	197	165		65
PSM10-9	577	345	922	197	165		66
PSM10-10	607	355	962	230	188		74
PSM10-12	667	355	1022	230	188		76
PSM10-14	747	390	1137	260	208	200	100
PSM10-16	807	390	1197	260	208		102
PSM10-18	867	390	1257	260	208		107
PSM10-20	927	390	1317	260	208		109
PSM10-22	987	390	1377	260	208		111
PSM12-2	367	290	657	190	155	140	39
PSM12-3	397	290	687	190	155	140	43
PSM12-4	437	345	782	197	165	160	51
PSM12-5	467	345	812	197	165	160	53
PSM12-6	497	355	852	230	188	160	61
PSM12-7	547	390	937	260	208	200	73
PSM12-8	577	390	967	260	208	200	74
PSM12-9	607	390	997	260	208	200	76
PSM12-10	637	390	1027	260	208	200	83
PSM12-12	697	390	1087	260	208	200	87
PSM12-14	845	500	1345	330	255	350	157
PSM12-16	905	500	1405	330	255	350	161
PSM12-18	965	500	1465	330	255	350	164

Continued 50Hz

Model	Size (mm)						Weight (kg)
	B1	B2	B1+B2	D1	D2	D3	
PSM15-1	387	245	632	170	142	120	33
PSM15-2	397	290	687	190	155	140	42
PSM15-3	452	345	797	197	165	160	51
PSM15-4	497	355	852	230	188	160	60
PSM15-5	542	355	897	230	188	160	62
PSM15-6	607	390	997	260	208	200	78
PSM15-7	652	390	1042	260	208	200	80
PSM15-8	697	390	1087	260	208	200	86
PSM15-9	742	390	1132	260	208	200	88
PSM15-10	875	500	1375	330	255	350	157
PSM15-12	965	500	1465	330	255	350	161
PSM15-14	1055	500	1555	330	255	350	165
PSM15-17	1190	500	1690	330	255	350	178
PSM16-2	397	290	687	190	155	140	42
PSM16-3	452	345	797	197	165	160	50
PSM16-4	497	355	852	230	188	160	59
PSM16-5	562	390	952	260	208	200	76
PSM16-6	607	390	997	260	208	200	77
PSM16-7	652	390	1042	260	208	200	84
PSM16-8	697	390	1087	260	208	200	86
PSM16-10	875	500	1375	330	255	350	158
PSM16-12	965	500	1465	330	255	350	161
PSM16-14	1055	500	1555	330	255	350	174
PSM16-16	1145	500	1645	330	255	350	178

Continued 50Hz

Model	Size (mm)						Weight (kg)
	B1	B2	B1+B2	D1	D2	D3	
PSM20-1	387	245	632	170	142	120	33
PSM20-2	397	290	687	190	155	140	42
PSM20-3	452	355	807	230	188	160	58
PSM20-4	517	390	907	260	208	200	74
PSM20-5	562	390	952	260	208	200	76
PSM20-6	607	390	997	260	208	200	82
PSM20-7	652	390	1042	260	208	200	84
PSM20-8	785	500	1285	330	255	350	153
PSM20-10	875	500	1375	330	255	350	157
PSM20-12	965	500	1465	330	255	350	170
PSM20-14	1055	500	1555	330	255	350	172
PSM20-17	1190	550	1740	330	255	350	195
PSM32-10-1/PSM32-10	505	290	795	190	155	140	64/68
PSM32-20-2/PSM32-20	575	345/355	920/930	197/230	165/180	160	77/85
PSM32-30-2/PSM32-30	645	390	1035	260	208	200	100
PSM32-40-2/PSM32-40	715	390	1105	260	208	200	109
PSM32-50-2/PSM32-50	890	500	1390	330	255	350	181
PSM32-60-2/PSM32-60	960	500	1460	330	255	350	185
PSM32-70-2/PSM32-70	1030	500	1530	330	255	350	199
PSM32-80-2/PSM32-80	1100	500	1600	330	255	350	203
PSM32-90-2/PSM32-90	1170	550	1720	330	255	350	222
PSM32-100-2/PSM32-100	1240	550	1790	330	255	350	227
PSM32-110-2/PSM32-110	1310	575	1885	360	285	350	272
PSM32-120-2/PSM32-120	1380	575	1955	360	285	350	276
PSM32-130-2/PSM32-130	1450	650	2100	400	310	400	337
PSM32-140-2/PSM32-140	1520	650	2170	400	310	400	341
PSM32-150-2/PSM32-150	1590	650	2240	400	310	400	345
PSM32-160-2/PSM32-160	1660	650	2310	400	310	400	350

Continued 50Hz

Model	Size (mm)						Weight (kg)
	B1	B2	B1+B2	D1	D2	D3	
PSM42-10-1 PSM42-10	561	345/355	906/916	197/230	165/188	160	83/90
PSM42-20-2 PSM42-20	641	390	1031	260	208	200	105/110
PSM42-30-2 PSM42-30	826	500	1326	330	255	350	183
PSM42-40-2 PSM42-40	906	500	1406	330	255	350	197
PSM42-50-2 PSM42-50	986	550	1536	330	255	350	221
PSM42-60-2 PSM42-60	1066	575	1641	360	285	350	261
PSM42-70-2 PSM42-70	1146	650	1796	400	310	400	320
PSM42-80-2 PSM42-80	1226	650	1876	400	310	400	324
PSM42-90-2 PSM42-90	1306	650	1956	400	310	400	328/352
PSM42-100-2 PSM42-100	1386	650	2036	400	310	400	355
PSM42-110-2 PSM42-110	1466	685	2151	460	340	450	426
PSM42-120-2 PSM42-120	1546	685	2231	460	340	450	432
PSM42-130-2	1626	685	2311	460	340	450	438
PSM65-10-1	561	355	916	230	188	160	93
PSM65-10	561	390	951	260	208	200	105
PSM65-20-2	644	390	1034	260	208	200	110
PSM65-20-1	754	500	1254	330	255	350	182
PSM65-20	754	500	1254	330	255	350	182
PSM65-30-2	836	500	1336	330	255	350	196
PSM65-30-1	836	500	1336	330	255	350	197
PSM65-30	836	550	1386	330	255	350	221
PSM65-40-2	919	550	1469	330	255	350	225
PSM65-40-1	919	575	1494	360	285	350	258
PSM65-40	919	575	1494	360	285	350	258
PSM65-50-2	1001	650	1651	400	310	400	319
PSM65-50-1	1001	650	1651	400	310	400	319
PSM65-50	1001	650	1651	400	310	400	320
PSM65-60-2	1084	650	1734	400	310	400	325
PSM65-60-1	1084	650	1734	400	310	400	349
PSM65-60	1084	650	1734	400	310	400	349
PSM65-70-2	1166	650	1816	400	310	400	353
PSM65-70-1	1166	650	1816	400	310	400	353
PSM65-70	1166	685	1851	400	310	450	420
PSM65-80-2	1248	685	1933	460	340	450	424
PSM65-80-1	1248	685	1933	460	340	450	424

Continued 50Hz

Model	Size (mm)						Weight (kg)
	B1	B2	B1+B2	D1	D2	D3	
PSM85-10-1	571	390	961	260	208	200	105
PSM85-10	571	390	961	260	208	200	110
PSM85-20-2	773	500	1273	330	255	350	181
PSM85-20	773	500	1273	330	255	350	192
PSM85-30-2	865	550	1415	330	255	350	215
PSM85-30	865	575	1440	360	285	350	252
PSM85-40-2	957	650	1607	400	310	400	312
PSM85-40	957	650	1607	400	310	400	312
PSM85-50-2	1049	650	1699	400	310	400	336
PSM85-50	1049	650	1699	400	310	400	336
PSM85-60-2	1141	685	1826	460	340	450	407
PSM85-60	1141	685	1826	460	340	450	407
PSM120-10	840	500	1340	330	255	350	230
PSM120-20-2	1000	500	1500	330	255	350	245
PSM120-20-1	1000	550	1550	330	255	350	250
PSM120-20	1000	575	1575	360	285	350	285
PSM120-30-2	1160	650	1810	400	310	400	360
PSM120-30-1	1160	650	1810	400	310	400	360
PSM 120-30	1160	650	1810	400	310	400	360
PSM120-40-2	1320	650	1970	400	310	400	400
PSM120-40-1	1320	650	1970	400	310	400	400
PSM120-40	1320	685	2005	460	340	450	460
PSM 120-50-2	1480	685	2165	460	340	450	470
PSM120-50-1	1480	685	2165	460	340	450	470
PSM120-50	1510	760	2270	540	370	550	575
PSM120-60-2	1670	760	2430	540	370	550	585
PSM120-60-1	1670	760	2430	540	370	550	585
PSM120-60	1670	865	2535	580	410	550	705
PSM120-70-2	1830	845	2675	580	410	550	715
PSM120-70-1	1830	845	2675	580	410	550	715
PSM120-70	1830	845	2675	580	410	550	715

Continued 50Hz

Model	Size (mm)						Weight (kg)
	B1	B2	B1+B2	D1	D2	D3	
PSM150-10-1	840	500	1340	330	255	350	230
PSM150-10	840	500	1340	330	255	350	235
PSM150-20-2	1000	550	1550	330	255	350	250
PSM150-20-1	1000	575	1575	360	285	350	295
PSM150-20	1000	650	1650	400	310	400	350
PSM150-30-2	1160	650	1810	400	310	400	360
PSM150-30-1	1160	650	1810	400	310	400	360
PSM150-30	1160	650	1810	400	310	400	385
PSM150-40-2	1320	685	2005	460	340	450	460
PSM150-40-1	1320	685	2005	460	340	450	460
PSM150-40	1350	760	2110	540	370	550	560
PSM150-50-2	1510	760	2270	540	370	550	570
PSM150-50-1	1510	845	2355	580	410	550	690
PSM150-50	1510	845	2355	580	410	550	690
PSM150-60-2	1670	845	2515	580	410	550	700
PSM150-60-1	1670	845	2515	580	410	550	700
PSM150-60	1670	845	2515	580	410	550	700
PSM200-10-B	907	550	1457	330	255	350	311
PSM200-10-A	907	575	1482	360	285	350	347
PSM200-10	907	650	1557	400	310	400	403
PSM200-20-2B	1101	650	1751	400	310	400	447
PSM200-20-2A	1101	685	1786	460	340	450	504
PSM200-20-A	1131	760	1891	540	370	550	595
PSM200-20	1131	760	1891	540	370	550	595
PSM200-30-2B	1325	845	2170	580	410	550	748
PSM200-30-A-B	1325	845	2170	580	410	550	748
PSM200-30-2A	1325	845	2170	580	410	550	748
PSM200-30-B	1325	845	2170	580	410	550	748
PSM200-30-A	1325	845	2170	580	410	550	748
PSM200-30	1325	895	2220	580	410	550	817
PSM200-40-2B	1519	895	2414	580	410	550	830
PSM200-40-2A	1519	1140	2659	645	550	660	1180
PSM200-40-A	1519	1140	2659	645	550	660	1180
PSM200-40	1519	1140	2659	645	550	660	1180

Table 1 Pump outline dimensions 60Hz

Model	Size (mm)					Weight (kg)
	B1	B2	B1+B2	D1	D2	
PSM1-2	258	225	483	148	117	20
PSM1-3	276	225	501	148	117	20
PSM1-4	294	225	519	148	117	21
PSM1-5	312	225	537	148	117	22
PSM1-6	330	225	555	148	117	23
PSM1-7	358	245	603	170	142	26
PSM1-8	376	245	621	170	142	27
PSM1-9	394	245	639	170	142	28
PSM1-10	412	245	657	170	142	29
PSM1-11	430	245	675	170	142	29
PSM1-12	448	245	693	170	142	30
PSM1-13	466	245	711	170	142	31
PSM1-15	512	290	802	190	155	37
PSM1-17	548	290	838	190	155	38
PSM1-19	584	290	874	190	155	41
PSM1-21	620	290	910	190	155	42
PSM1-23	656	290	946	190	155	43
PSM1-25	702	345	1047	197	165	51
PSM2-2	258	225	483	148	117	21
PSM2-3	286	245	531	170	142	24
PSM2-4	304	245	549	170	142	25
PSM2-5	322	245	567	170	142	26
PSM2-6	340	245	585	170	142	26
PSM2-7	368	290	658	190	155	32
PSM2-9	404	290	694	190	155	36
PSM2-11	440	290	730	190	155	37
PSM2-13	486	345	831	197	165	44
PSM2-15	522	345	867	197	165	45
PSM2-18	576	355	931	230	188	54

Continued 60Hz

Model	Size (mm)					Weight (kg)
	B1	B2	B1+B2	D1	D2	
PSM3-2	258	225	483	148	117	20
PSM3-3	276	225	501	148	117	21
PSM3-4	294	225	519	148	117	22
PSM3-5	322	245	567	170	142	25
PSM3-6	340	245	585	170	142	26
PSM3-7	358	245	603	170	142	27
PSM3-8	376	245	621	170	142	27
PSM3-9	404	290	694	190	155	33
PSM3-10	422	290	712	190	155	34
PSM3-11	440	290	730	190	155	34
PSM3-12	458	290	748	190	155	37
PSM3-13	476	290	766	190	155	38
PSM3-15	512	290	802	190	155	39
PSM3-17	548	290	838	190	155	40
PSM3-19	594	345	939	197	165	48
PSM3-21	630	345	975	197	165	49
PSM3-23	666	345	1011	197	165	50
PSM3-25	702	355	1057	230	188	58
PSM4-2	286	245	531	170	142	24
PSM4-3	313	245	558	170	142	25
PSM4-4	350	290	640	190	155	31
PSM4-5	376	290	667	190	155	34
PSM4-6	404	290	694	190	155	35
PSM4-7	441	345	786	197	165	42
PSM4-8	468	345	813	197	165	42
PSM4-10	522	355	877	230	188	51
PSM4-12	576	355	931	230	188	52
PSM4-14	650	390	1040	260	208	64
PSM4-16	704	390	1094	260	208	66

Continued 60Hz

Model	Size (mm)					Weight (kg)
	B1	B2	B1+B2	D1	D2	
PSM5-2	276	225	501	148	117	27
PSM5-3	303	245	548	170	142	29
PSM5-4	330	245	575	170	142	29
PSM5-5	367	290	657	190	155	34
PSM5-6	394	290	684	190	155	37
PSM5-7	421	290	711	190	155	37
PSM5-8	448	290	738	190	155	38
PSM5-9	485	290	775	190	155	38
PSM5-10	512	345	857	197	165	47
PSM5-11	539	345	884	197	165	47
PSM5-12	566	345	911	197	165	48
PSM5-13	593	355	948	230	188	56
PSM5-14	620	355	975	230	188	57
PSM5-15	647	355	1002	230	188	57
PSM5-16	684	355	1039	230	188	58
PSM5-18	738	390	1128	260	208	76
PSM5-20	782	390	1172	260	208	77
PSM5-22	846	390	1236	260	208	78
PSM5-24	900	390	1290	260	208	82
PSM8-2/1	347	245	592	170	142	32
PSM8-2	357	290	647	190	155	38
PSM8-3	387	290	677	190	155	41
PSM8-4	427	345	772	197	165	49
PSM8-5	457	345	802	197	165	50
PSM8-6	487	355	842	230	188	58
PSM8-8	567	390	957	260	208	71
PSM8-10	627	390	1017	260	208	80
PSM8-12	687	390	1077	260	208	82
PSM8-14	835	500	1335	330	255	153

Continued 60Hz

Model	Size (mm)					Weight (kg)
	B1	B2	B1+B2	D1	D2	
PSM10-1	347	245	592	170	142	40
PSM10-2	347	290	637	190	155	47
PSM10-3	377	290	667	190	155	51
PSM10-4	417	345	762	197	165	60
PSM10-5	447	345	792	197	165	61
PSM10-6	477	355	832	230	188	70
PSM10-7	517	390	907	260	208	92
PSM10-8	547	390	937	260	208	93
PSM10-9	577	390	967	260	208	94
PSM10-10	607	390	997	260	208	98
PSM10-12	667	390	1057	260	208	100
PSM10-14	747	500	1247	330	255	157
PSM10-16	807	500	1307	330	255	159
PSM10-17	837	500	1337	330	255	160
PSM12-1	357	245	602	170	142	32
PSM12-2	367	290	657	190	155	41
PSM12-3	407	355	762	230	188	56
PSM12-4	457	390	847	260	208	69
PSM12-5	487	390	877	260	208	71
PSM12-6	517	390	907	260	208	77
PSM12-7	547	390	937	260	208	78
PSM12-8	665	500	1165	330	255	147
PSM12-10	725	500	1225	330	255	151
PSM12-12	785	500	1285	330	255	164
PSM12-14	845	500	1345	330	255	167

Continued 60Hz

Model	Size (mm)					Weight (kg)
	B1	B2	B1+B2	D1	D2	
PSM15-1	397	290	687	190	155	39
PSM15-2	407	345	752	197	165	49
PSM15-3	452	355	807	230	188	58
PSM15-4	517	390	907	260	208	71
PSM15-5	562	390	952	260	255	81
PSM15-6	695	500	1195	330	255	150
PSM15-7	740	500	1240	330	255	152
PSM15-8	785	500	1285	330	255	153
PSM15-9	830	500	1330	330	255	165
PSM15-10	875	500	1375	330	255	167
PSM15-12	965	550	1515	330	255	191
PSM16-2/1	397	290	687	190	155	42
PSM16-2	407	355	762	230	188	56
PSM16-3	472	390	862	260	208	68
PSM16-4	517	390	907	260	208	75
PSM16-5	650	500	1150	330	255	148
PSM16-6	695	500	1195	330	255	150
PSM16-7	740	500	1240	330	255	161
PSM16-8	785	500	1285	330	255	163
PSM16-10	875	550	1425	330	255	186

Continued 60Hz

Model	Size (mm)					Weight (kg)
	B1	B2	B1+B2	D1	D2	
PSM20-1	397	290	687	190	155	41
PSM20-2	407	355	762	230	188	56
PSM20-3	472	390	862	260	208	69
PSM20-4	517	390	907	260	208	79
PSM20-5	650	500	1150	330	255	148
PSM20-6	695	500	1195	330	255	150
PSM20-7	740	500	1240	330	255	162
PSM20-8	785	500	1285	330	255	163
PSM20-10	875	550	1425	330	255	187
PSM32-10-1	505	345	850	197	165	73
PSM32-10	505	355	860	230	188	81
PSM32-20-2	575	390	965	260	208	95
PSM32-20	575	390	965	260	208	101
PSM32-30-2	645	390	1035	330	255	104
PSM32-30	750	500	1250	330	255	172
PSM32-40-2	820	500	1320	330	255	176
PSM32-40	820	500	1320	330	255	186
PSM32-50-2	890	500	1390	330	255	191
PSM32-50	890	550	1440	330	255	211
PSM32-60-2	960	550	1510	330	255	216
PSM32-60	960	550	1510	330	255	216
PSM32-70-2	1030	575	1605	360	285	255
PSM32-70	1030	575	1605	360	285	255
PSM32-80-2	1100	575	1675	400	310	259
PSM32-80	1100	650	1750	400	310	315
PSM32-90-2	1170	650	1820	400	310	319
PSM32-90	1170	650	1820	400	310	319
PSM32-100-2	1240	650	1890	400	310	324

Continued 60Hz

Model	Size (mm)					Weight (kg)
	B1	B2	B1+B2	D1	D2	
PSM42-1 0-1	561	390	952	260	208	101
PSM42-10	561	390	952	260	208	106
PSM42-20-2	748	500	1248	330	255	178
PSM42-20	748	500	1248	330	255	188
PSM42-30-2	828	550	1378	330	255	213
PSM42-30	828	550	1378	330	255	213
PSM42-40-2	908	575	1483	360	285	253
PSM42-40	908	650	1558	400	310	309
PSM42-50-2	988	650	1638	400	310	313
PSM42-50	988	650	1638	400	310	313
PSM42-60-2	1068	650	1718	400	310	340
PSM42-60	1068	650	1718	400	310	340
PSM42-70-2	1148	685	1833	460	340	404
PSM42-70	1148	685	1833	460	340	404
PSM65-1 0-1	561	390	951	260	208	109
PSM65-10	671	500	1171	330	255	177
PSM65-20-2	754	500	1254	330	255	187
PSM65-20	754	575	1329	360	285	248
PSM65-30-2	836	575	1411	360	285	252
PSM65-30	836	650	1486	400	310	313
PSM65-40-2	919	650	1569	400	310	336
PSM65-40	919	685	1604	460	340	398
PSM65-50-2	1001	685	1686	460	340	402

Continued 60Hz

Model	Size (mm)					Weight (kg)
	B1	B2	B1+B2	D1	D2	
PSM85-10-1	571	500	1071	330	255	177
PSM85-10	571	500	1071	330	255	188
PSM85-20-2	773	550	1323	330	255	211
PSM85-20-1	773	575	1348	360	285	248
PSM85-20	773	650	1423	400	310	304
PSM85-30-2	865	650	1515	400	310	330
PSM85-30-1	865	650	1515	400	310	330
PSM85-30	865	685	1550	460	340	392
PSM85-40-2	957	685	1642	460	340	396
PSM120-10-1	840	500	1340	330	255	235
PSM120-10	840	550	1390	330	255	250
PSM120-20-2	1000	650	1650	400	310	350
PSM120-20-1	1000	650	1650	400	310	350
PSM120-20	1000	650	1650	400	310	380
PSM 120-30-2	1160	685	1845	460	340	445
PSM 120-30-1	1160	685	1845	460	340	445
PSM120-30	1190	685	1950	510	370	545
PSM 120-40-2	1350	845	2195	580	410	675
PSM120-40-1	1350	845	2195	580	410	675
PSM120-40	1350	845	2195	580	410	675
PSM120-50-2	1510	845	2355	580	410	690

Continued 60Hz

Model	Size (mm)					Weight (kg)
	B1	B2	B1+B2	D1	D2	
PSM150-10-1	840	490	1330	330	255	235
PSM150-10	840	500	1340	360	285	280
PSM150-20-2	1000	575	1415	400	310	360
PSM150-20-1	1000	650	1650	400	310	380
PSM150-20	1000	650	1650	460	340	435
PSM150-30-2	1190	685	1685	510	370	545
PSM150-30-1	1190	760	1950	580	410	665
PSM150-30	1190	845	2035	580	410	665
PSM150-40-2	1350	845	2195	580	410	680
PSM200-1 0-B	907	650	1557	400	310	403
PSM200-10-A	907	650	1557	400	310	426
PSM200-10	907	685	1592	450	345	484
PSM200-20-2B	1131	760	1891	540	370	595
PSM200-20-2A	1131	845	1976	580	410	718
PSM200-20-B	1131	845	1976	580	410	718
PSM200-20-A	1131	895	2026	580	410	787
PSM200-20	1131	895	2026	580	410	787
PSM200-30-2B	1325	1140	2465	645	550	1158
PSM200-30-A-B	1325	1140	2465	645	550	1158
PSM200-30-2A	1325	1140	2465	645	550	1158

Table 2 Installation size

Model Size		PSM																		
		1	2	3	4	5	8	10	12	15	16	20	32	42	65	85	120	150	200	
Round flange connection	DN	25		32		40		50			65	80	100	125	150					
	PI	60				80				107	120	150	175	203						
	P	85		100		110		125			145	160	180	220	250					
	P2	115		140		150		165			185	200	220	270	300					
	n-d1	4-φ14		4-φ18				8-φ18				8-φ28								
	C	250				280		300		320	365	380	380	490						
	E	75				80		90		105	140		180	200						
	h	32				25		35		30	45		40	40						
	Nominal pressure	PN25										PN25-40		PN16		PN25-40				
Cutting Ferrule Joint connection	D	42				60														
	C	210				260														
	E	50				80		90												
	h	20				25		35												
Pipe thread connection.	D	ZG1½				ZG2														
	C	210				260														
	E	50				80		90												
	h	20				25		35												
Oval flange connection	D	G1		G1¼		G1½														
	C	162				200														
	E	50				80														
	h	20				25														
	P	75				100														
	n-d1	2-M10×40				2-M12×45														
	k	22																		
Footer size	G	100				130				170	190	199	275	385						
	G1	150				199				225	245	255	340	460						
	M	180				215				240	266	280	380	500						
	M1	210				247				298	330	348	472	600						
	d2	13				14								18	20					

Table 3 Flange torque

Flangetype	Force			Torque		
	Fy	Fz	Fx	My	Mz	Mx
DN25/32	750	1150	770	800	950	1200
DN40	980	1245	1090	880	1000	1250
DN50	1345	1600	1450	980	1130	1350
DN65	1650	2050	1850	1050	1200	1450
DN80	2000	2450	2200	1150	1300	1600
DN100	2670	3300	3000	1200	1440	1750
DN125/150	2700	3350	3000	1250	1450	1750

The pump should be sited in a well ventilated and frost-free position. The distance between pump-motor and other objects should be at least 150mm , in order to cool the motor by fan with enough air.

- In order to minimize the inlet wear, the inlet pipe shall be as short as possible;
 - Ensure the check valve is installed in pipe line system before the pump installation to avoid the fluid reflux. If pump is used for boiler water supply, a check valve must be installed in the piping between pump and boiler;
 - Pump should be installed in cement base or other similar base with suitable height. It can also be installed in fixed grounds or fixed brackets on the wall. Pay attention not to let the weight of pipe system concentrate on pump to prevent pump from damage;
- Caution: When installation, motor is not allowed to be hung upside down.
- Arrow on the inlet and outlet chamber shows the direction of flow of liquid through the pump. Check whether the liquid can flow easily before starting pump;
 - Before pump installation, the inlet pipe line shall be cleaned. If there is impurities in the pipe, it is necessary to install a strainer at 0.5-1m in front of the pump inlet (particularly recommended for pump with flow less than 8m³/h);

The air lock shall be avoided when installing the inlet pipe line. Refer to Fig. 4;

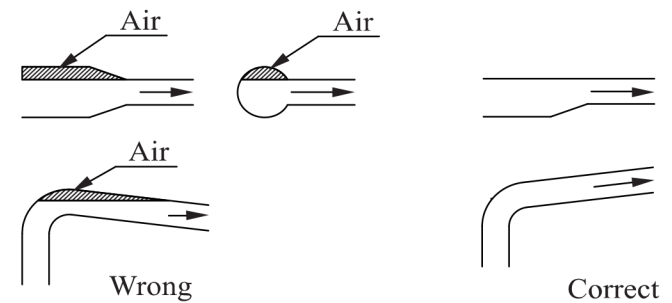

Figure 4

- If the outlet globe valve might be closed(or the flow is decreased to zero), a bypass shall be installed in outlet pipeline to ensure adequate lubrication and cooling water to pass the pump.

2.Electrical connection

- The electrical connections should be carried out by an authorized electrician;

- To make sure the motor is suitable for the power supply, cables of the motor must be connected to power supply according to the Fig. on the terminal box and the motor nameplate;

- Motor shall be connected with a fast and effective motor starter, to ensure that the motor will not be damaged by lack of phase, unstable voltage or overload. The motor shall be earthed reliably;

Caution: Before taking apart the terminal box cover or dismantle pump, pump, make sure that the power supply is switched off.

Warning - Electrical connection and safety devices

- The pump units should be connected to the power supply by the appropriately rated power cables according to the motor rating.

- The pump units should always be equipped with safety devices as required in the standards (EN 809 and/or EN 60204-1) as well as by the national rules of the country where the pump is used.

- Despite the rules of any country, the power supply to the pump unit must be equipped with at least following electrical safety devices with appropriate ratings:

- Emergency switch.

- Circuit breaker (as a supply disconnecting (isolating) device as well as an overcurrent protective device).

- Motor overload protection.

Recommendation for Electrical Connection and Safety Devices

380V(50Hz/60Hz)					
No	Motor power (kW)	Cable connection	Current (A)		Cable spec (mm ²)
			YE2/IE2	YE3/IE3	
1	0.37	Y	1.0	1.0	0.75
2	0.55	Y	1.4	1.4	0.75
3	0.75	Y	1.8	1.7	0.75
4	1.1	Y	2.5	2.4	1
5	1.5	Y	3.3	3.2	1
6	2.2	Y	4.7	4.6	1.5
7	3	Y	6.2	6.0	1.5
8	4	Δ	8.0	7.8	2.5
9	5.5	Δ	10.9	10.6	2.5
10	7.5	Δ	14.5	14.4	4
11	11	Δ	21.0	20.6	4
12	15	Δ	28.4	27.9	6
13	18.5	Δ	34.7	34.2	10
14	22	Δ	41.1	40.5	16
15	30	Δ	55.7	54.9	16
16	37	Δ	68.3	67.4	25
17	45	Δ	82.7	80.8	35
18	55	Δ	101	99.6	35
19	75	Δ	137	133.7	50
20	90	Δ	163	160	70
21	110	Δ	197	195	95

The acoustic noise emission is around 85 dB(A).

A. Before opening the terminal box, please shut off the power supply to prevent from electric shock.

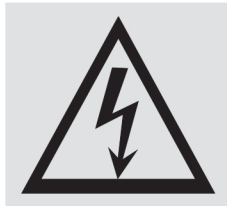

B. Before opening the coupling guards, please stop pump firstly to prevent from hurts.

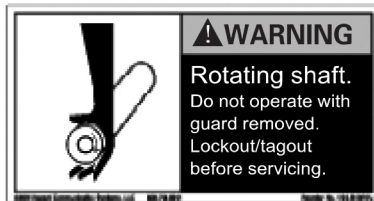

C. When installing the pump, please fix the foundation bolts vertically to prevent from pump falling to hurt people.

D. Please fill grease to the pump when it requires.

For motor power less than 5.5kW, it is free of filling grease. For motor power equal or higher than 5.5kW, please fill grease every 5000 running hours.



E. Warning: Avoid personal contact to prevent scalding injury if the pump is used to convey hot liquid.



Fig.5 shows the pump parts whose temperature may equal to the liquid temperature

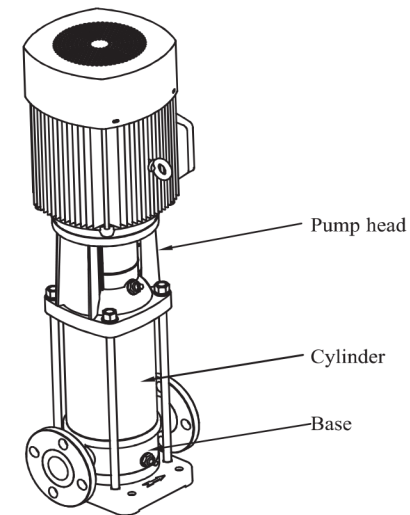

Fig.5 Hot surface of CR,CRI,CRN pump

V. Start-up, operation and maintenance

Caution: Read the label on the cylinder carefully before start-up.

1. Do not start the pump until it has been filled with water or liquid fully.

- Fill water in pump in inverse pouring system.

Close the pump outlet valve, release air vent screw on the pump head, and open the inlet valve slowly until stable water flows from the air vent screw. Then fasten the screw. Open the check valve completely in the inlet pipeline.

• In open system, fill water in pump when liquid surface is lower than pump.

Notice: A check valve shall be installed in the inlet pipe.

Close the pump outlet valve, release air vent screw and fill the liquid in pump through the air vent screw hole until the pump and inlet pipe line are filled with water fully. Fasten the air vent screw again.

Caution: Do not start the pump until it has been filled with liquid fully and air vented. Be careful the direction of the air vent screw hole. Make sure the flowing water will not hurt persons or pump or its parts. Especially, prevent from hurting for the hot water application.

2. Check the rotary direction

Switch on the power supply and view the rotary direction by viewing the motor fan. Arrow on the pump head indicates the correct direction of rotation. That is, from the motor end, pump shall run counter-clockwise.

3. Check before pump start-up

- Check whether the foundation bolt is fasten;
- Check whether pump is filled with water fully;
- Check whether the voltage of power supply is correct;
- Check whether it turns correctly;
- To make sure all pipe lines are connected tightly and can supply water normally;
- The valves in the inlet pipe line are completely opened and the outlet valve shall be opened slowly after the pump is started up;
- Check the operation pressure if pressure meter is installed;
- Check all the controls for normal operation. If the pump is controlled by pressure switch, check and adjust the starting pressure and stopping pressure. Check the full load current to make sure it will not exceed the max. Current.

4. Frequency of pump starts

Pump should not be started too frequently. It is suggested pump shall not be started more than 100 times per hour if the motor power is less or equal to 4kW. When motor power is more than 4kW, pump shall not be sta-

rted more than 20 times in one hour. If pump starts and stops too frequently, control device shall be checked and adjusted to make pump not start and stop too frequently. Also, it is necessary to check the installation.

5. Suggestion: The operation of pump should according to the range of performance curve to avoid motor overload.

6. Pump which is installed according to this installation manual will work effectively with little maintenance.

• Mechanical seal will be adjusted automatically, the rotating part and stationary part is lubricated and cooled by the transferring liquid. When replace the mechanical seal, the user needn't to disassemble the motor for power higher than 7.5kW;

• The bearing in pump is lubricated by the transferring liquid.

7. Frost Protecting

Pump can be used in the system with anti-frozen measures to water. If the pump is installed in easily frozen place, suitable antifreeze shall be added to the transferring liquid to prevent pump from being damaged. If antifreeze is not used, pump shall be stopped when it might frozen. Pumps which are not being used should be drained.

8. The following should be checked regularly for pump.

- Pump working and operating pressure;
- Possible leakage;
- Possible motor overheat;
- Cleaning/replacement of all strainers;
- The switch off time of motor when overload;
- Frequency of starts and stops;
- All control operation;

If malfunction is found, check system according to "Fault finding and solution chart"

9. Pump shall be cleaned and kept appropriately when it is not used for a long time.

10. Pump shall be prevented from being corrupted and damaged in storage.

VI. Assemble and disassemble

1.PSM1,2,3,4,5

- Put the circlip cover on the shaft, and then fit the sleeve, impeller, impeller sleeve, diffuser, support diffuser. Continue the assemble order till the last impeller is fitted. Then fit the impeller cover, washer, screw the nut. Pay attention to the position of the support diffuser, for pump with less stages, the last one is support diffuser. For pump with more stages, support diffuser should be increased accordingly, the distance of each support diffuser should be even, and put on the support sleeve and bearing with support diffuser;
 - Put the inducer on the inlet & outlet chamber, and then fit the finished parts as above on the inducer;
 - Fit the O-ring on the inlet & outlet chamber, put on the cylinder and the top diffuser;
 - Put the pump head installed with O-ring, lining and corrugated spring on the cylinder. Screw the four nuts of the stay bolts on the base plate. Do not tighten one nut completely at one time, but tighten them symmetrically in turn;
 - Fit the mechanical seal and tighten it , then install motor and coupling, screw the bolts in coupling (but not tightly), press the coupling and shaft down to the direction of the base plate. Then lift it about 1mm in reverse direction, tighten the screws. Note that the space between the two couplings should be equal;
 - Tighten fasten screws in mechanical seal, rotate the coupling to ensure that the shaft can rotate freely and not be choked;
- Reverse the process above can disassemble a pump.

2.PSM8,10,12,15,16,20

- Put the circlip cover on the shaft, and then fit the sleeve, impeller, impeller sleeve, diffuser, support diffuser, bearing, support sleeve. Continue the assemble order till the last impeller is fitted, and then install the impeller cover, washer, tighten the nuts;
- Put the inlet & outlet chamber on the base plate, then put the O-ring, clamp plate, inducer on inlet & outlet chamber, then put the finished parts on the inducer, and put the top diffuser on the top, tighten nuts of straps. At last, put on the cylinder;
- Put the pump head installed with O-ring, lining and adjusting rubber on the cylinder, then tighten the four stay bolts symmetrically in turn;
- Fit the mechanical seal and tighten it , then install motor and coupling, screw the bolts in coupling (but not tightly), press the coupling and shaft down to the direction of the base plate. Then lift it about 1mm in reverse di-

rection, tighten the screws. Note that the space between the two couplings should be equal;

- Tighten fasten screws in mechanical seal, rotate the coupling to ensure that the shaft can rotate freely and not be choked;
- Reverse the process above can disassemble a pump.

3.PSM32, 42, 65, 85

- 4.Put the inlet & outlet chamber on the base plate, fit flanges on inlet & outlet chamber at two sides, and fit the inducer;
 - Put the first impeller on the shaft, tighten the nuts and put the impeller on the neck ring base of inducer, then put on the diffuser, impeller, support diffuser, until the top diffuser, then fix all the diffuser with the straps;
 - shaft parts: fit the bottom sleeve, cover, washer on the shaft, tighten the bolts, fit bottom bearing on the inlet & outlet chamber, fit washer. Then put the shaft parts on the inlet & outlet chamber, fit on O-ring, lubricate the O ring and then put on the cylinder;
 - Fit stay bolts on the base plate, then fit the O-ring, adjusting rubber, air vent gag on the pump head, and put the pump head on the stay bolts, then put on the washer and tighten all the nuts;
 - Fit the mechanical seal on the pump head, then fit the seal cover, tighten the bolts, and the bolts in the seal. Lift the shaft and insert the adjusting slice;
 - Fit the bracket and motor on the pump head;
- Finally fit the coupling, tighten the bolts, and take out the adjusting slice. Rotate the coupling to ensure that the shaft can rotate freely and not be choked. Reverse the above process to disassemble a pump.

4.PSM120, 150, 200

- 5.Put the inlet & outlet chamber on the base plate, fit flanges on inlet & outlet chamber at two sides, and fit the inducer;
- Fit washer, shaft sleeve, inlet impeller sleeve, cover, washer, fasten the nut;
- Fit impeller shaft sleeve, impeller, fasten impeller nut, ensure the size is 14.3[for PSM120&150] or 25.5[for PSM200] as figure 6 shows;

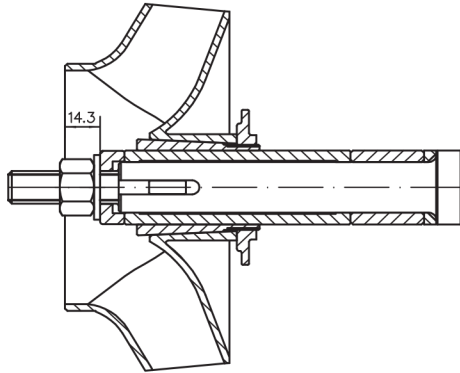

Figure 6

- Put the shaft parts on the inducer, fit support diffuser, impeller sleeve, impeller, fasten impeller nut, then, fit diffuser, impeller, etc. till the last diffuser;
- Fit the top diffuser, use straps to fasten all diffusers. Fit O-ring on the inlet and outlet chamber, lubricate them and put on cylinder;
- Fit stay bolts on the base plate, fit O-ring on the pump head, adjusting rubber, air vent screw, etc. Then put pump head on the stay bolts, fit washer, fasten nut;
- Fit the mechanical seal on the pump head, then fit the seal cover, tighten the bolts, and tighten the bolts in the seal. Lift the shaft and insert the adjusting slice;
- Fit the bracket and motor on the pump head. Finally fit the coupling, tighten the bolts, and take out the adjusting slice. Rotate the coupling to ensure that the shaft can rotate freely and not be choked and loose. Reverse the above process to disassemble a pump.

VII. Fault finding and Trouble shooting

Caution: Before removing the terminal box cover and before any removal/dismantling of the pump, make sure that the power supply has been switched off.

Fault	Cause	Solution	Remarks
Motor does not run when started	a) Possible power supply failure.	a) Check power supply.	
	b) Fuses are blown.	b) Replace fuses.	
	c) Motor is overloaded.	c) Check system.	
	d) Main contacts of starter are not connected well or the coil is defective.	d) Replace motor starter.	
	e) Control circuit is defective.	e) Check control circuit.	
	f) Motor is defective.	f) Repair.	
Overload device of motor starter trips out immediately when power supply is switched on.	a) Fuses are blown.	a) Replace fuses.	In the case of d) and e), users shall not disassemble the pump by themselves.
	b) Contacts of overload device are faulty.	b) Check motor starter.	
	c) Cable connection is loose or faulty.	c) Check cables and power supply	
	d) Motor winding is defective.	d) Replace motor	
	e) Pump mechanically blocked.	e) Check and repair pump	
Overload device trips out occasionally.	a) The setting of overload is too low.	a) Reset overload setting	
	b) Periodic power supply faults.	b) Check power supply	
	c) Low voltage at peak times.	c) Add regulator.	
Motor starter has not tripped out but the pump does not run.	a) Contacts of starter are not contacted well or the coil is faulty.	a) Change motor starter	
	b) Control circuit are defective	b) Check control circuit	

Continued

Fault	Cause	Solution	Remarks
Pumped water does not flow constantly	a) Suction pipe is too small.	a) Enlarge inlet pipeline	
	b) There is not sufficient water in pump water inlet.	b) Improve system and increase coming water	
	c) Liquid level is low.	c) Try to lift liquid level.	
	d) Pump inlet pressure is too low compared with water temperature, pipeline loss and flow.	d) Improve system and try to increase the inlet pressure.	
	e) Suction pipe is partly blocked by impurities.	e) Check and clear impurities.	
Pump runs but gives no water.	a) Suction pipe is blocked by impurities.	a) Check and clean suction pipe.	
	b) Foot valve or check valve is closed.	b) Check and repair foot valve or check valve.	
	c) Leakage in suction pipe.	c) Check and repair suction pipe.	
	d) There is air in suction pipe or pump.	d) Refill liquid, release air.	
Pump runs backwards when switched off.	a) Leakage in suction pipe.	a) Check suction pipe	
	b) Foot valve or check valve is defective.	b) Check and repair foot valve or check valve.	
	c) Foot valve is blocked in opened or partly opened position.	c) Check and repair foot valve.	
	d) There is air lock in suction pipe.	d) Check and repair suction pipe and release air.	

Continued

Fault	Cause	Solution	Remarks
Abnormal vibration or noise from pump	a) Leakage in suction pipe.	a) Check and repair suction pipe.	In the case of e), users shall not disassemble the pump by themselves.
	b) Suction pipe is too small or suction pipe is partly blocked by impurities.	b) Enlarge or check suction pipe.	
	c) There is air in suction pipe or pump.	c) Refill liquid to the pump and vent air.	
	d) The comparison of the delivery head of device with delivery head of pump is very low.	d) Improve system or choose another pump model.	
	e) Pump mechanically blocked.	e) Check and repair pump.	

VIII. Important notice

1. Customers will not be advised if this manual is updated.
2. Pump will be guaranteed for one year under normal operation with the correct model. Wearing part is not included.
3. Users shall be responsible for the damage if they disassemble the pumps by themselves in guaranteed period.