

End Suction Centrifugal/ Stainless Steel

**PST
& PSF**



www.flofab.com

001-cat-2017-pstpsf

HISTORY

Flo Fab was established in 1981 by Denis Gauvreau who created and developed the products line and constantly being perfected by Marc Gauvreau, as well as by a team of professional engineers and designers. It's a combination of existing designs from several renowned products and the innovative ideas of a new generation professionals.

Through the years, Flo Fab has acquired several companies and service entities including : AQUA-PROFAB (ASME Tanks manufacturer), MÉNARD, LÉONARD ÉLECTRIQUE, PMA. , Furthermore Flo Fab purchased equipment, fabrication designs and patterns from IDEALCO, a manufacturer of shell and tube type heat exchangers.

The after sales services, sales, engineering, R&D, production, quality control, accounting and administration departments of all the above companies share the same location.

In December 2014, Marc Gauvreau, son of the founder, acquired all shares of The company. Flo Fab and is constantly investing in new state of the art innovations new product like the XRI series and Prefab Skid for Hydronic Heating & cooling system, pumping systems. This has allowed Flo Fab to retain competent and experienced staff of professionals with varied and specialized abilities that constantly work on improving our existing products and add new engineered solutions that exceeding customer's expectations .

Flo Fab has grown quite rapidly and now proudly offers of a wide range of products available directly from one manufacturer. This includes pumps & pump packages, tanks, heat exchangers & hydronic accessories. This allows each project stakeholders to enjoy economical savings, peace of mind, best value for their investment and optimized total cost of ownership.

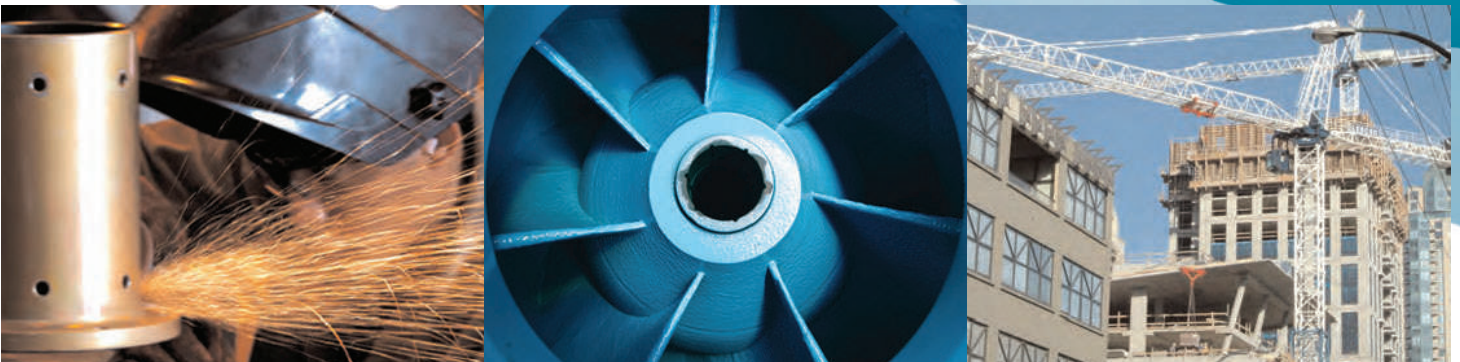



• Features

Model **PST / PSF** Close coupled design saves space; simplifies maintenance and installation

- Stainless steel liquid end components high quality; corrosion resistance
- Versatile mounting can be installed horizontally or vertically
- Back pullout construction assembly and overhaul of the impeller and seal without distorting suction and discharge connections
- Top centerline discharge and foot support under casing ensures self-venting and reduces misalignment from pipe loads
- High operating efficiency lowers operating costs
- High quality mechanical shaft seals and o-rings available for standard pumping requirements or optional high temperature and chemical duty operation

• Applications

- Plant services
- Water supply systems
- Washing plants
- Cooling water
- Car wash
- Scrubbers
- Ultrapure water systems
- Jockey pump services
- Air conditioning
- Sprinkler/flow irrigation
- OEM equipment application
- Pressure boosting
- Liquid transfer
- Heat exchanger
- Spray systems
- Heating
- Beverage processing
- Pharmaceutical services
- Water reclamation and treatment
- General pump applications



SERIES PS
Specifications
MODEL - PST

	Standard	Optional
Size		
Suction	PST70: 1/4" NPT thread PST120: 1/4" NPT thread PST200: 1/2" NPT thread	
Discharge	1" NPT thread	
H.P. Range	1/2 H.P. to 3 H.P.	
Performance Range		
Capacity	5.5 to 90 GPM at 3450 R.P.M.	
Head	23 to 144 feet at 3450 R.P.M.	
Liquid Handling		
Liquid Type	Various	
Temperature	Dependent on Mechanical Seal Selection	
Working Pressure	Max. 115 P.S.I.G. (8 Bar)	
Materials		
Casing	304 Stainless Steel	Various material options for high temperature, corrosive, and abrasive services.
Impeller (Closed Type)	304 Stainless Steel	
Shaft	Stainless Steel	
Bracket	Aluminum	
Mechanical Seal	Carbon vs. Ceramic (Buna Elastomers)	
Direction of Rotation	Clockwise when viewed from motor end	
Motor		
Type	NEMA 56J Frame	•Explosion Proof
Speed	60Hz 3450 RPM (2 poles)	•1750 RPM for lower flows and pressures
Single Phase	TEFC: 1/2 H.P. to 3 H.P. ODP: 1/2 H.P. to 3 H.P. 115/230V	
Three Phase	TEFC: 1/2 H.P. to 3 H.P. ODP: 1/2 H.P. to 3 H.P. 208-230/460V and 575V	
Motor Protection	Single Phase: Built-in overload protection Three Phase: Overload protection must be provided	



SERIES PS
 Cross Section
MODEL - PST
 Close-coupled

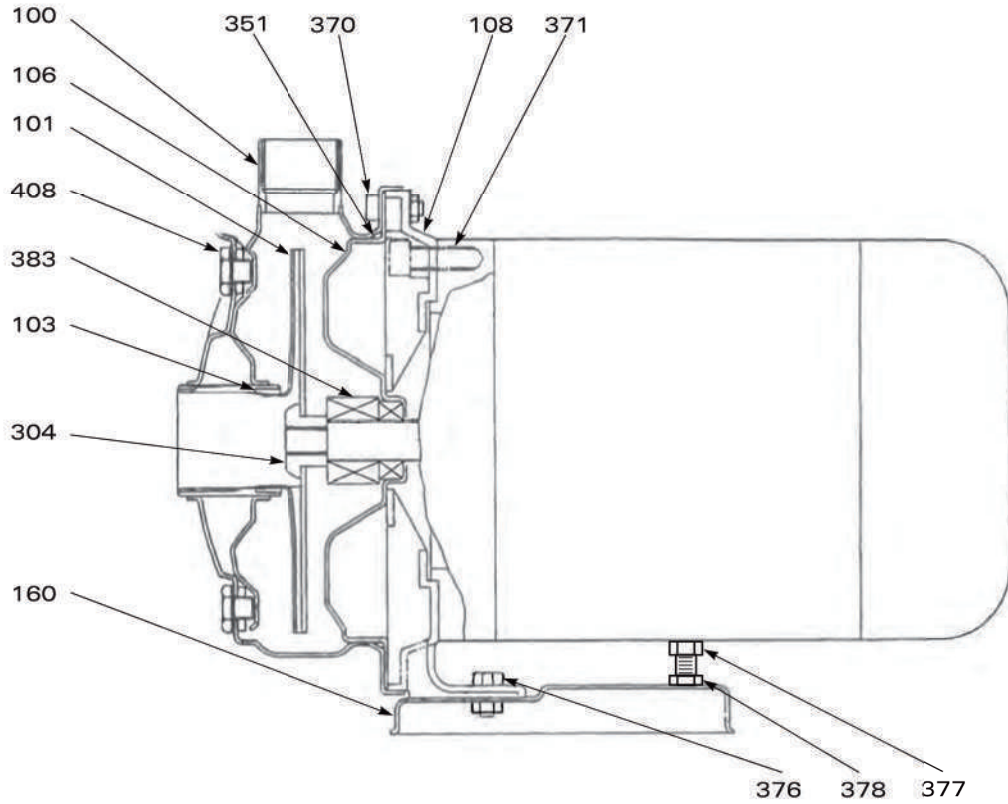

ITEM	QTY REQ'D	DESCRIPTION	MATERIAL
100	1	Casing	304 Stainless steel
101	1	Impeller	304 Stainless steel
103*	1	Casing ring	Viton
106	1	Casing cover	304 Stainless steel
108	1	Adapter	Aluminum
160	1	Motor support	Steel
304	1	Impeller nut	304 Stainless steel
351	1	Casing O-ring	Viton (standard)
370	8	Casing bolt	304 Stainless steel
371	4	Motor bolt	Steel
376	2	Foot bolt	Steel
377	1	Support bolt	Steel
378	1	Support bolt nut	Steel
383	1	Mechanical seal	Various
408	2	Casing plug	304 Stainless steel

* Required on sizes 701, 703 and 705 only.



SERIES PS
Cross Section
MODEL - PST
 Frame mounted

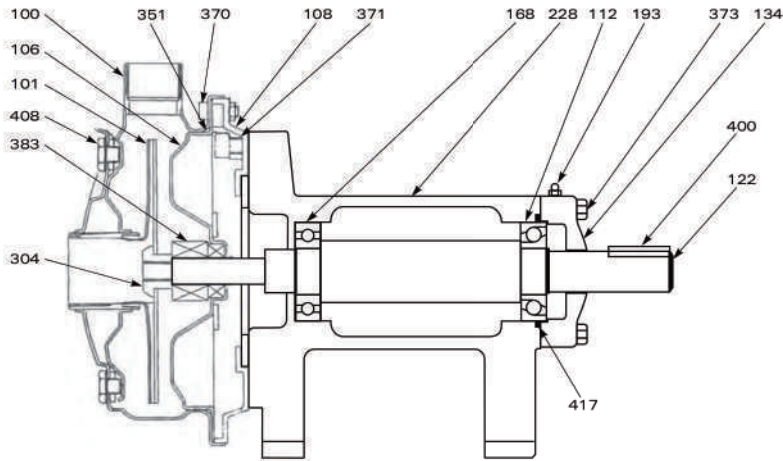

ITEM	QTY REQ'D	DESCRIPTION	MATERIAL
100	1	Casing	304 Stainless steel
101	1	Impeller	304 Stainless steel
103*	1	Casing wear ring	Viton
106	1	Casing cover	304 Stainless steel
108	1	Adapter	Aluminum
112	1	Thrust bearing	Steel
122	1	Shaft	Steel
134	1	Outboard brg cap	Cast iron
168	1	Radial bearing	Steel
178	1	Impeller key	Steel
193	1	Grease fitting	Steel
228	1	Bearing frame	Cast iron
304	1	Impeller nut	304 Stainless steel
351	1	Casing o-ring	Viton (standard)
370	8	Casing bolt	304 Stainless steel
371	4	Frame bolt	Steel
373	4	Bearing cap bolt	Steel
383	1	Mechanical seal	Various
400	1	Shaft key	Steel
408	2	Casing plug	304 Stainless steel
417	1	Retaining ring	Steel

* Required on sizes 701, 703 and 705 only.



SERIES PS Specifications MODEL - PST

Model PST Selection Chart (1725 RPM)

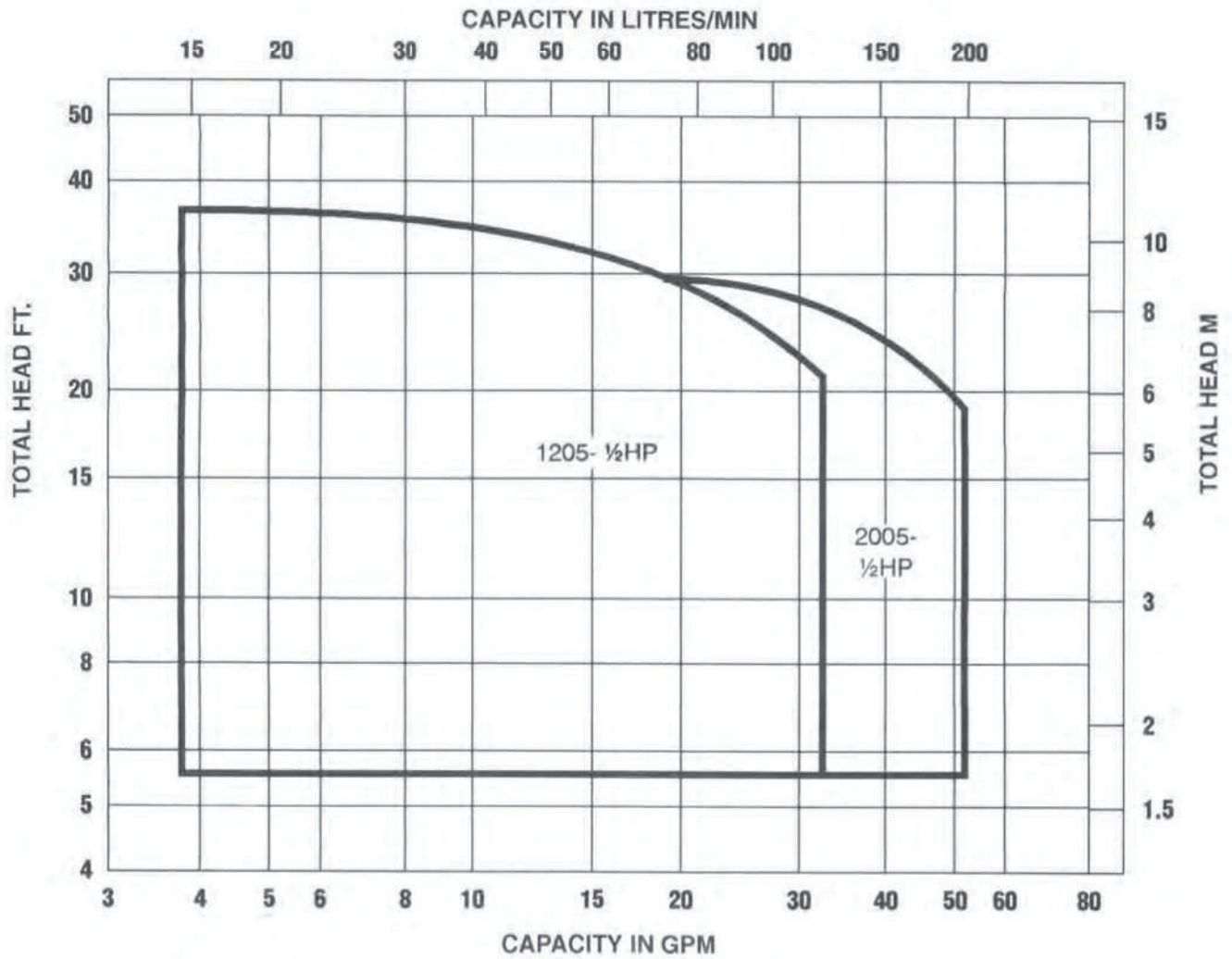



Series PS **MODEL PST1205**

CUSTOMER _____ REFERENCE _____

FLUID _____ S.G. _____ TEMP _____ CAPACITY _____ TDH _____

CERTIFIED: _____ DATE: _____

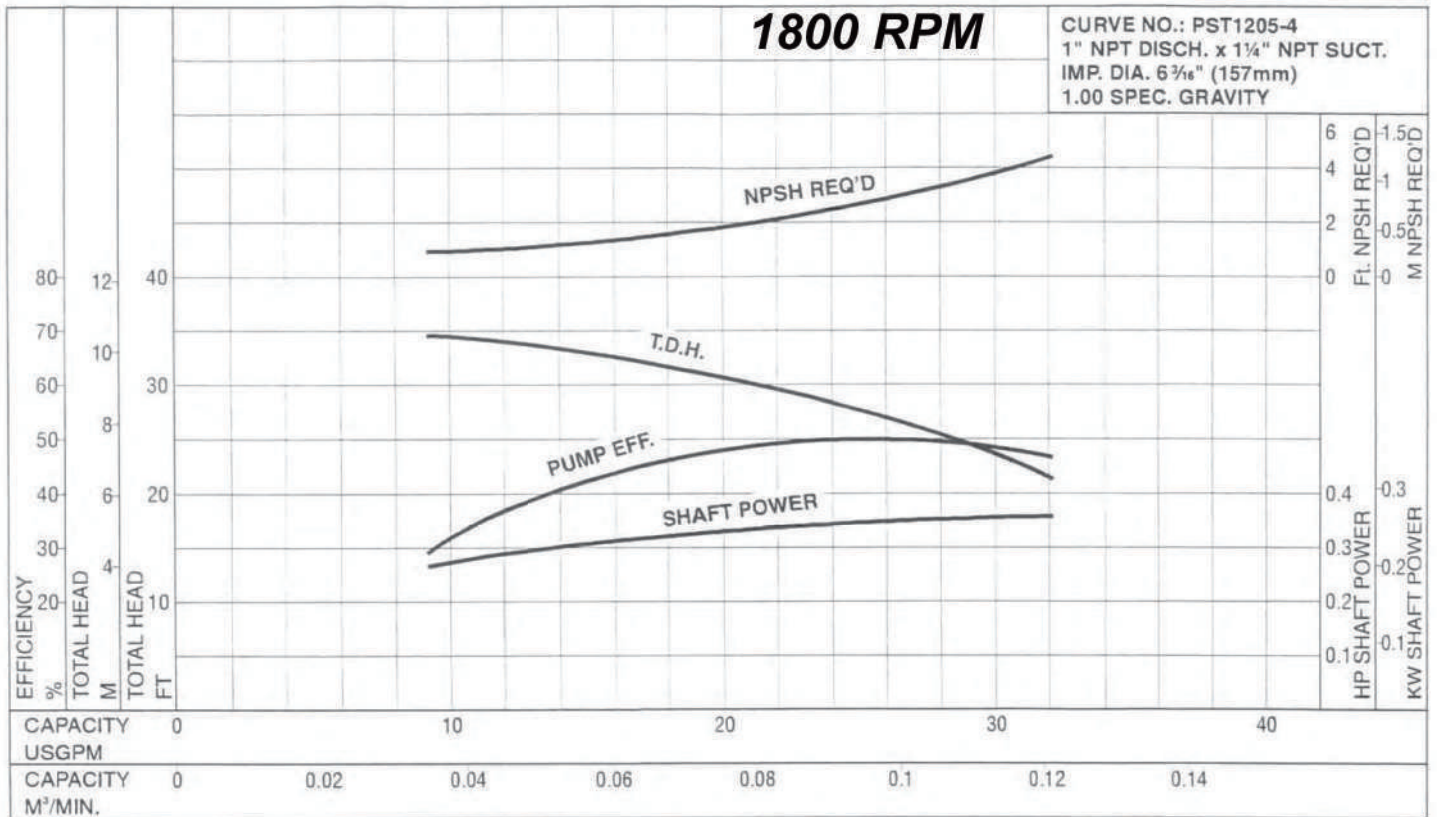



Series PS MODEL PST2005

CUSTOMER _____ REFERENCE _____

FLUID _____ S.G. _____ TEMP _____ CAPACITY _____ TDH _____

CERTIFIED: _____ DATE: _____

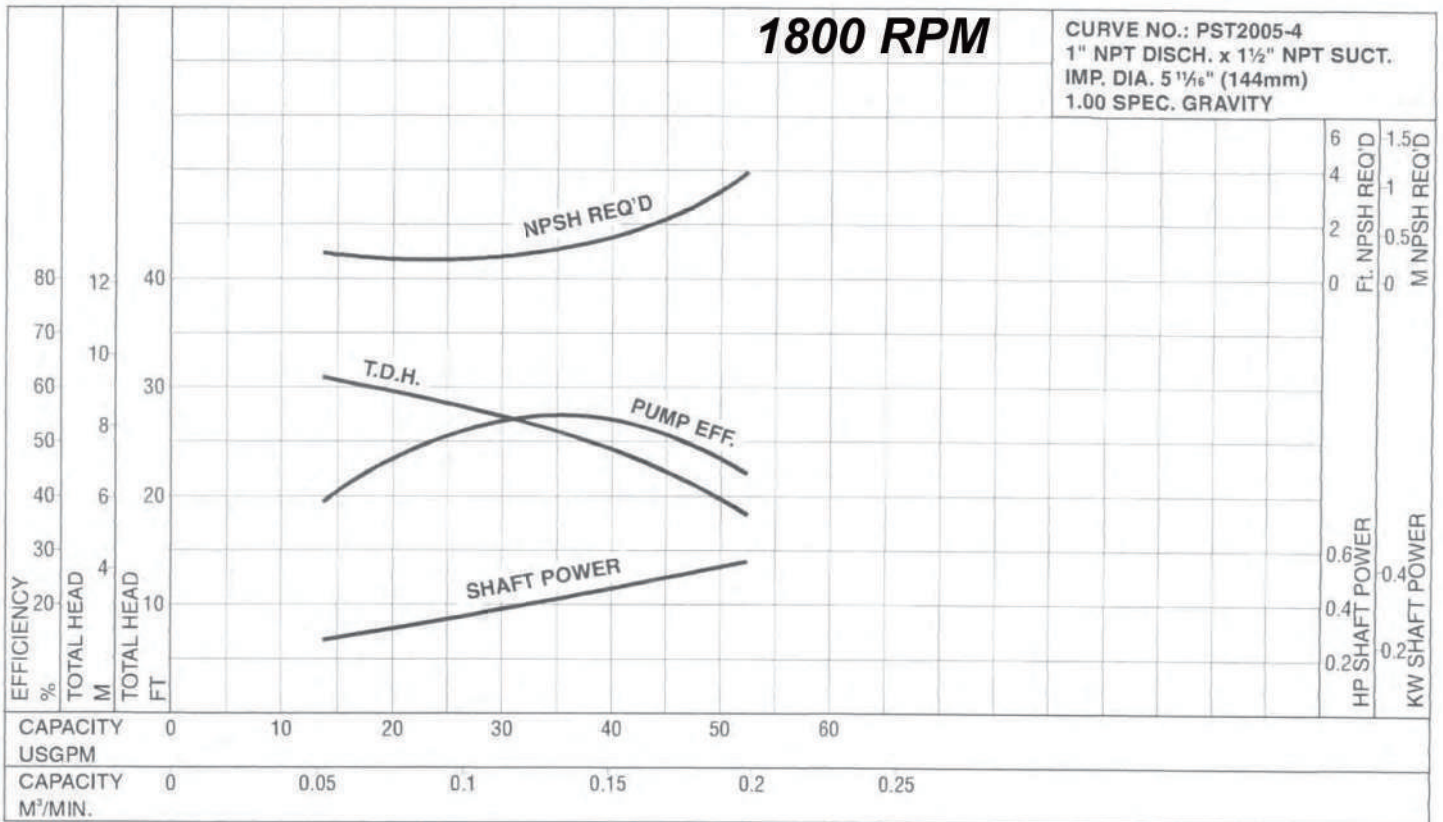



SERIES PS Specifications MODEL - PST

Model PST Selection Chart (3450 RPM)

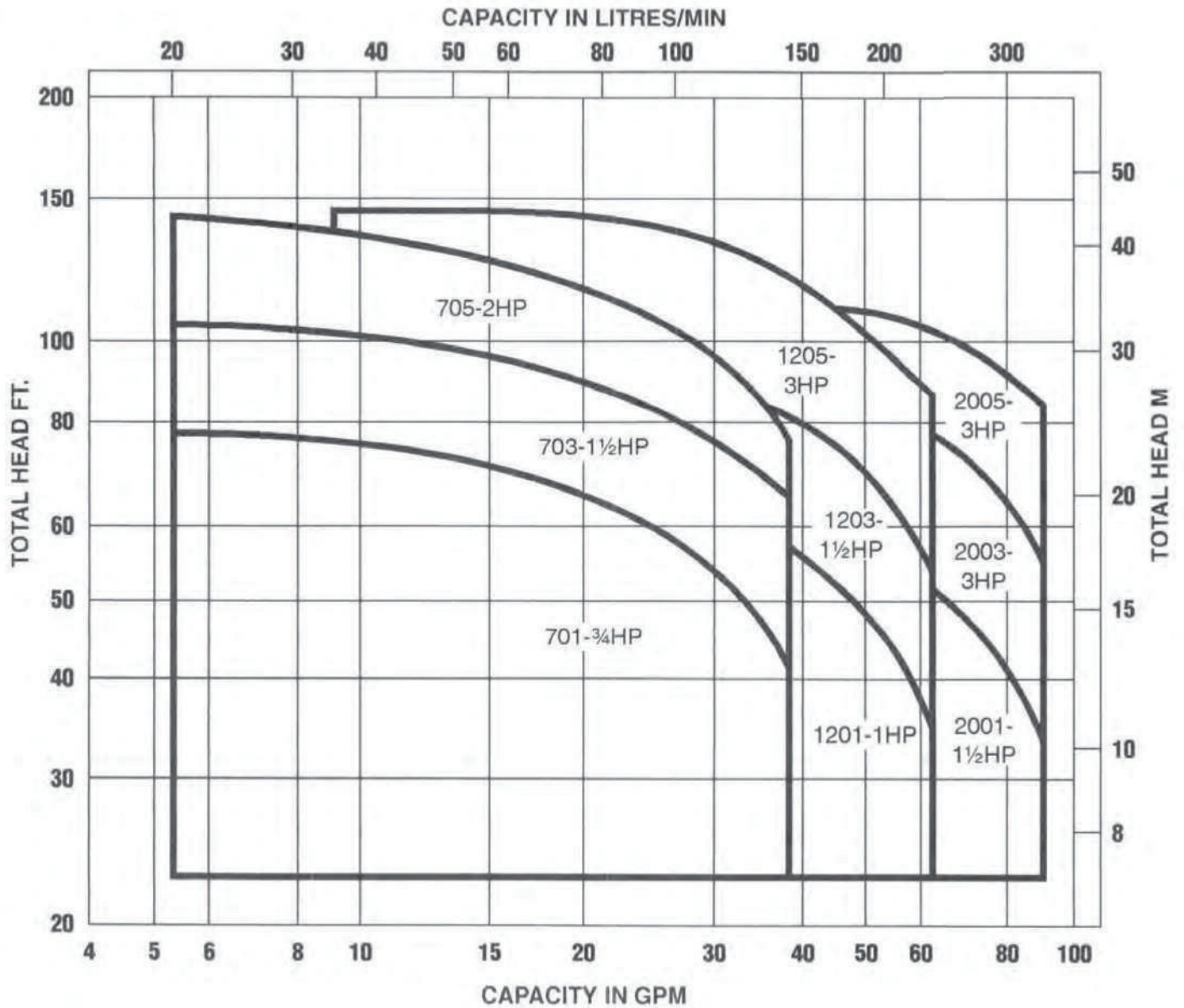



Series PS **MODEL PST701**

CUSTOMER _____ REFERENCE _____

FLUID _____ S.G. _____ TEMP _____ CAPACITY _____ TDH _____

CERTIFIED: _____ DATE: _____

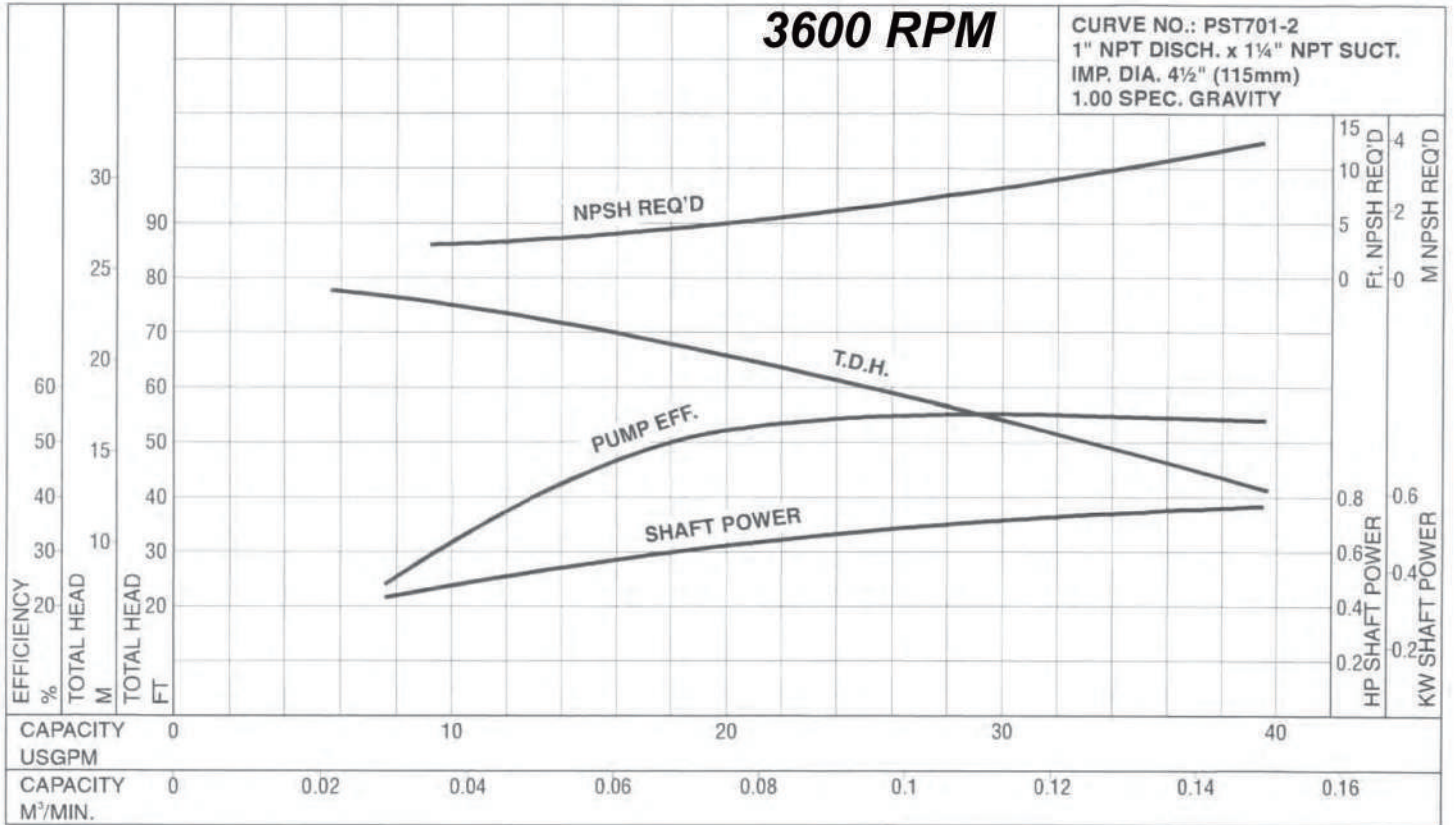



Series PS **MODEL PST703**

CUSTOMER _____ REFERENCE _____

FLUID _____ S.G. _____ TEMP _____ CAPACITY _____ TDH _____

CERTIFIED: _____ DATE: _____

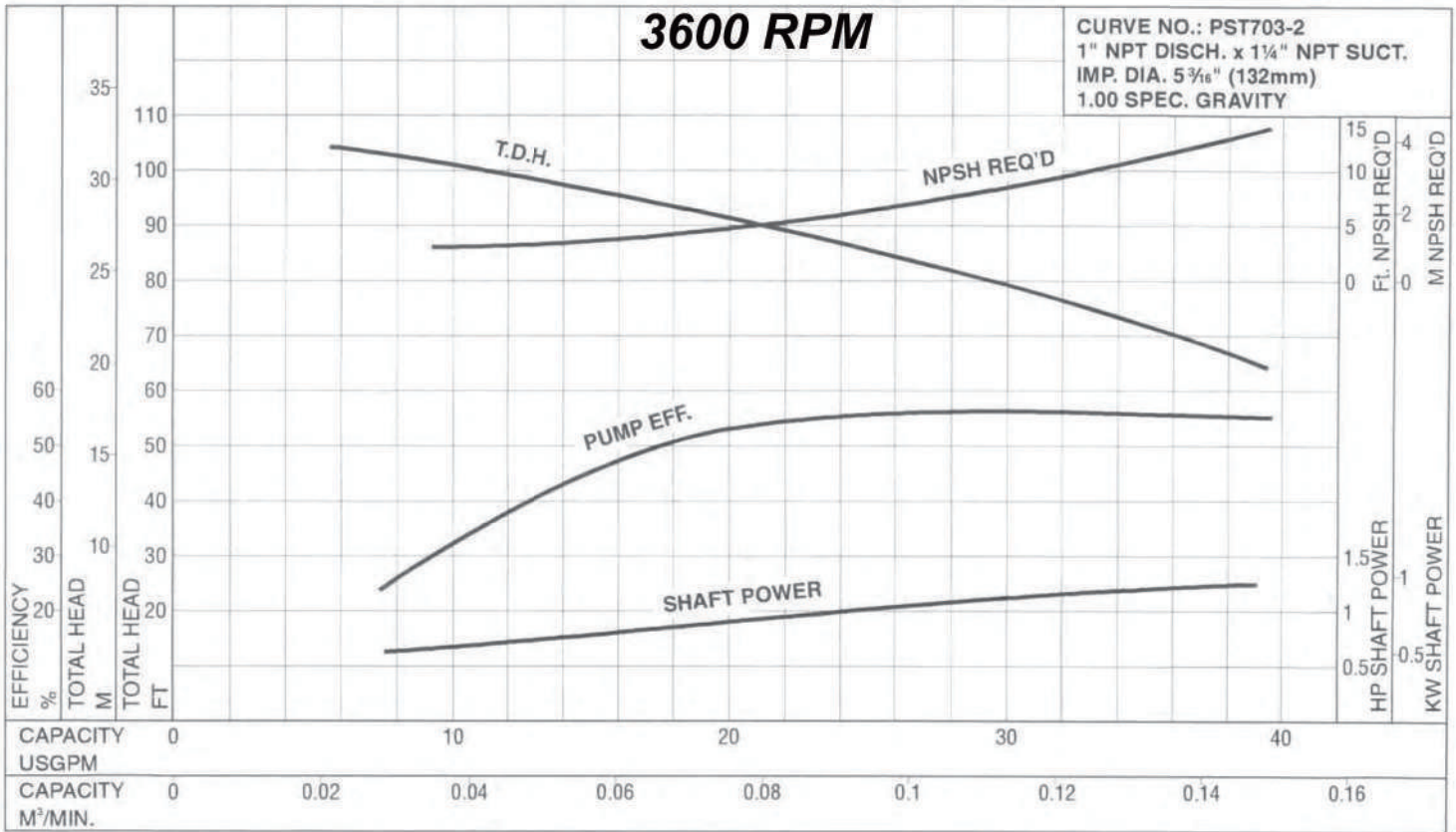



Series PS **MODEL PST705**

CUSTOMER _____ REFERENCE _____

FLUID _____ S.G. _____ TEMP _____ CAPACITY _____ TDH _____

CERTIFIED: _____ DATE: _____

3600 RPM

CURVE NO.: PST705-2
 1" NPT DISCH. x 1¼" NPT SUCT.
 IMP. DIA. 6 3/16" (157mm)
 1.00 SPEC. GRAVITY

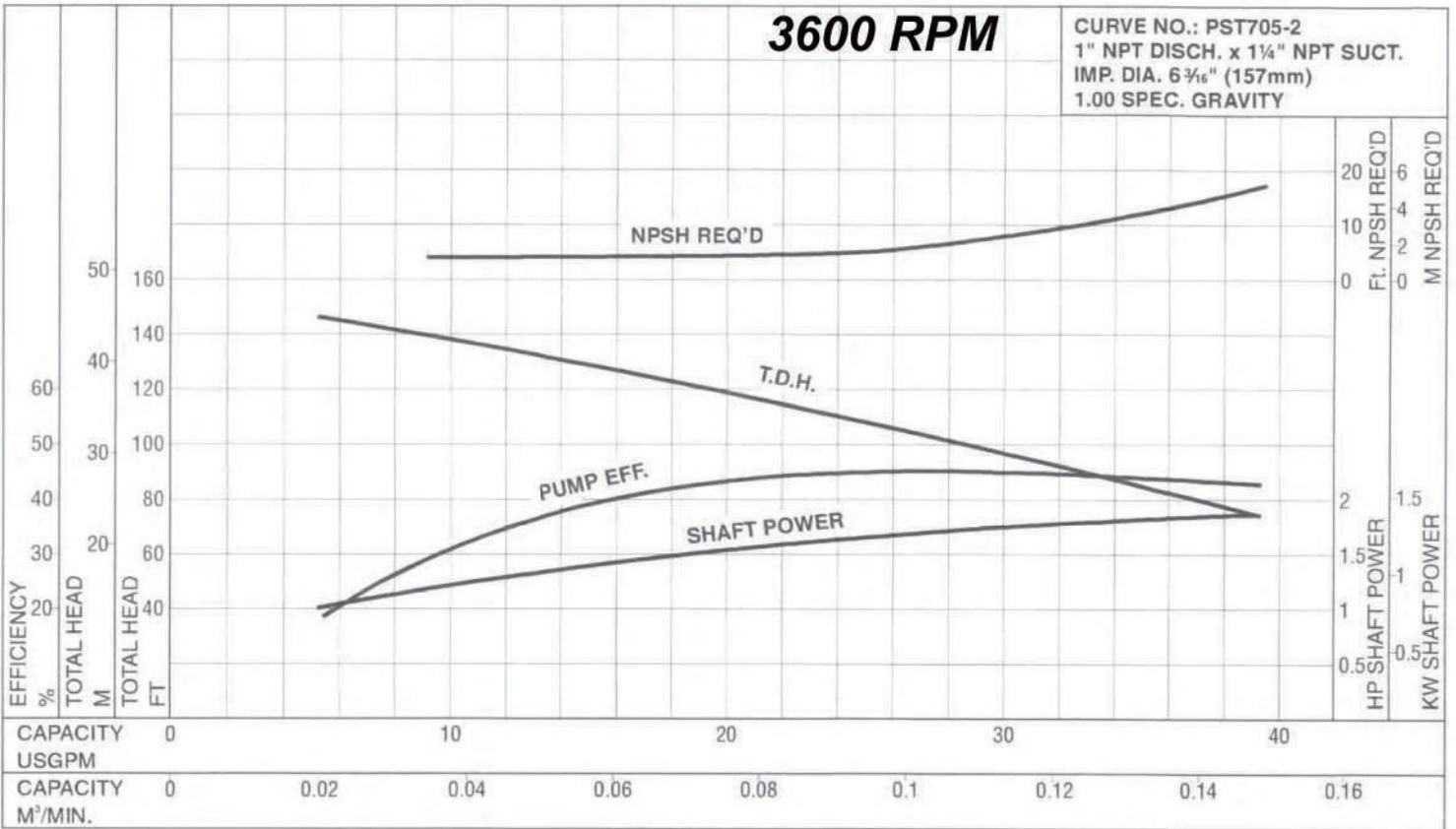



Series PS **MODEL PST1201**

CUSTOMER _____ REFERENCE _____

FLUID _____ S.G. _____ TEMP _____ CAPACITY _____ TDH _____

CERTIFIED: _____ DATE: _____

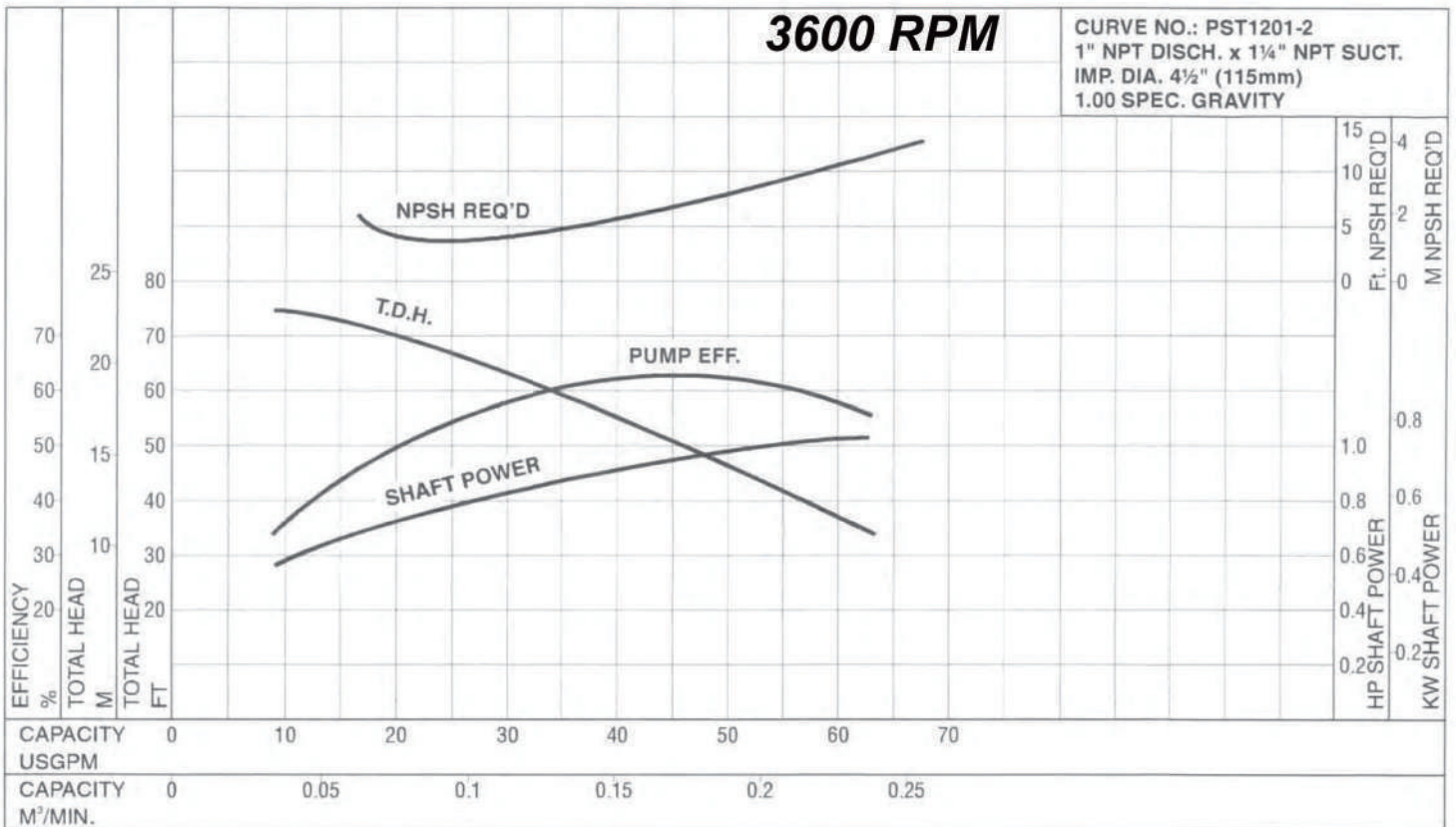



Series PS **MODEL PST1203**

CUSTOMER _____ REFERENCE _____

FLUID _____ S.G. _____ TEMP _____ CAPACITY _____ TDH _____

CERTIFIED: _____ DATE: _____

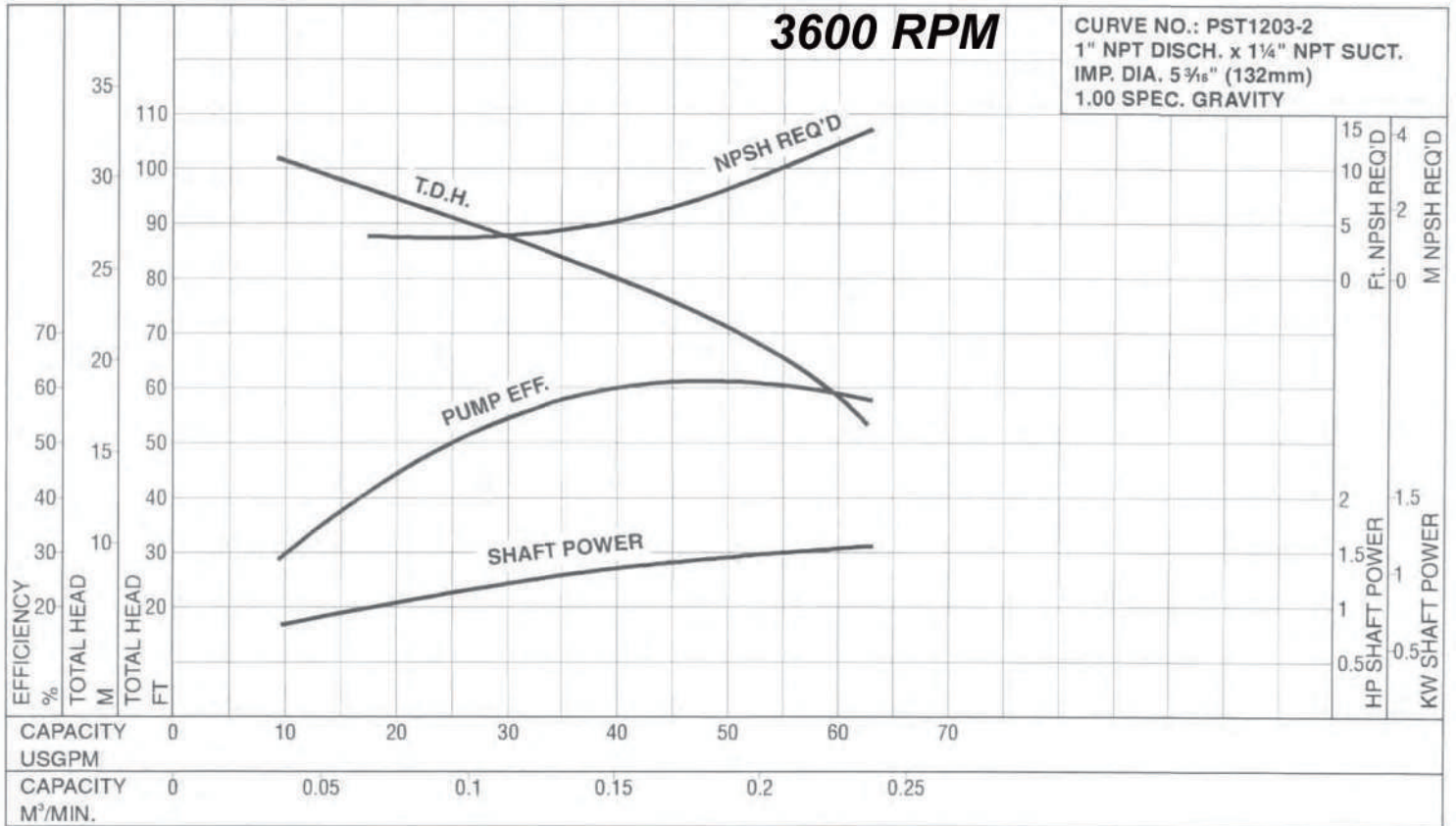



Series PS MODEL PST1205

CUSTOMER _____ REFERENCE _____

FLUID _____ S.G. _____ TEMP _____ CAPACITY _____ TDH _____

CERTIFIED: _____ DATE: _____

3600 RPM

CURVE NO.: PST1205-2
 1" NPT DISCH. x 1 1/4" NPT SUCT.
 IMP. DIA. 6 3/8" (157mm)
 1.00 SPEC. GRAVITY

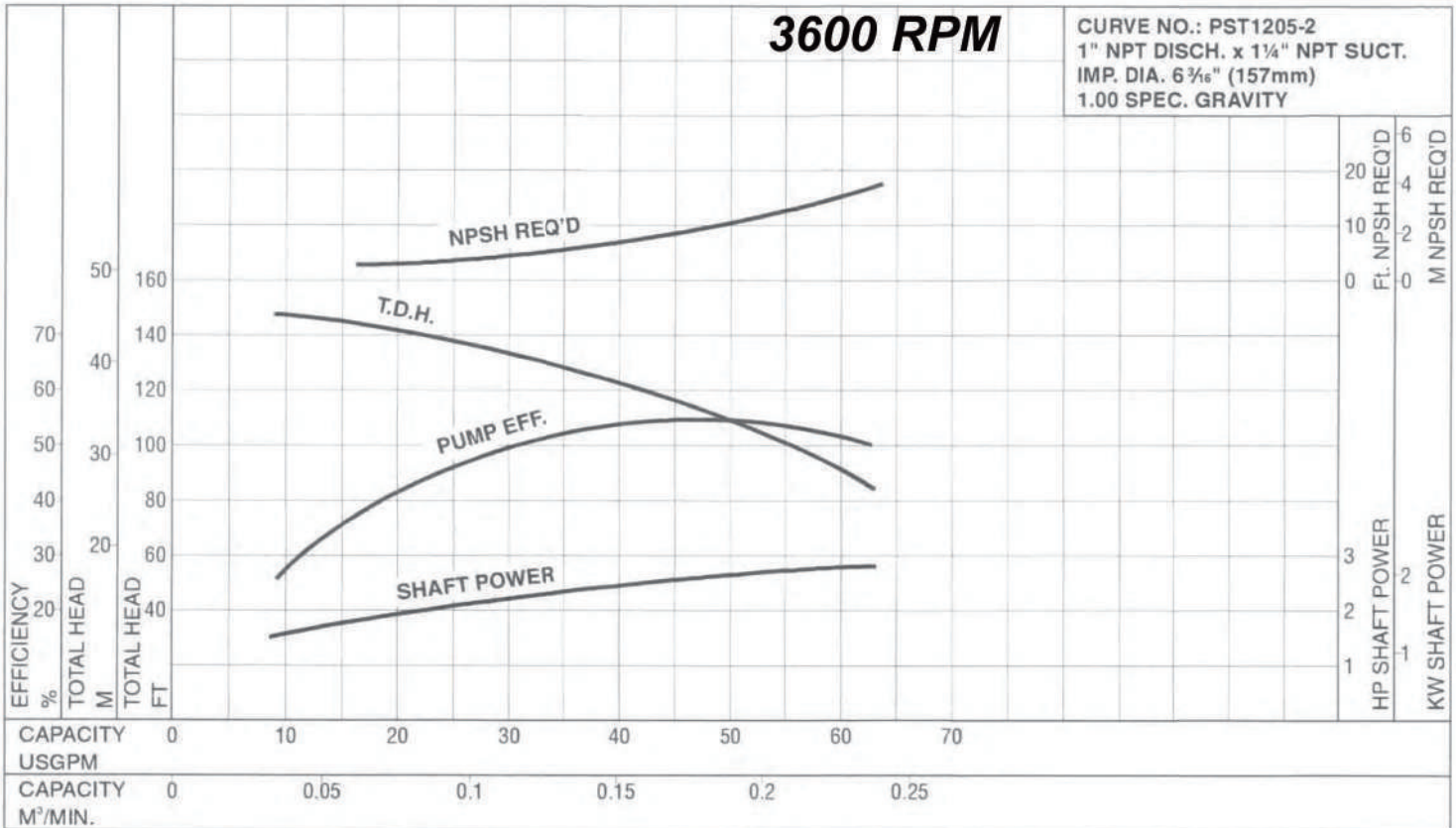



Series PS MODEL PST2001

CUSTOMER _____ REFERENCE _____

FLUID _____ S.G. _____ TEMP _____ CAPACITY _____ TDH _____

CERTIFIED: _____ DATE: _____

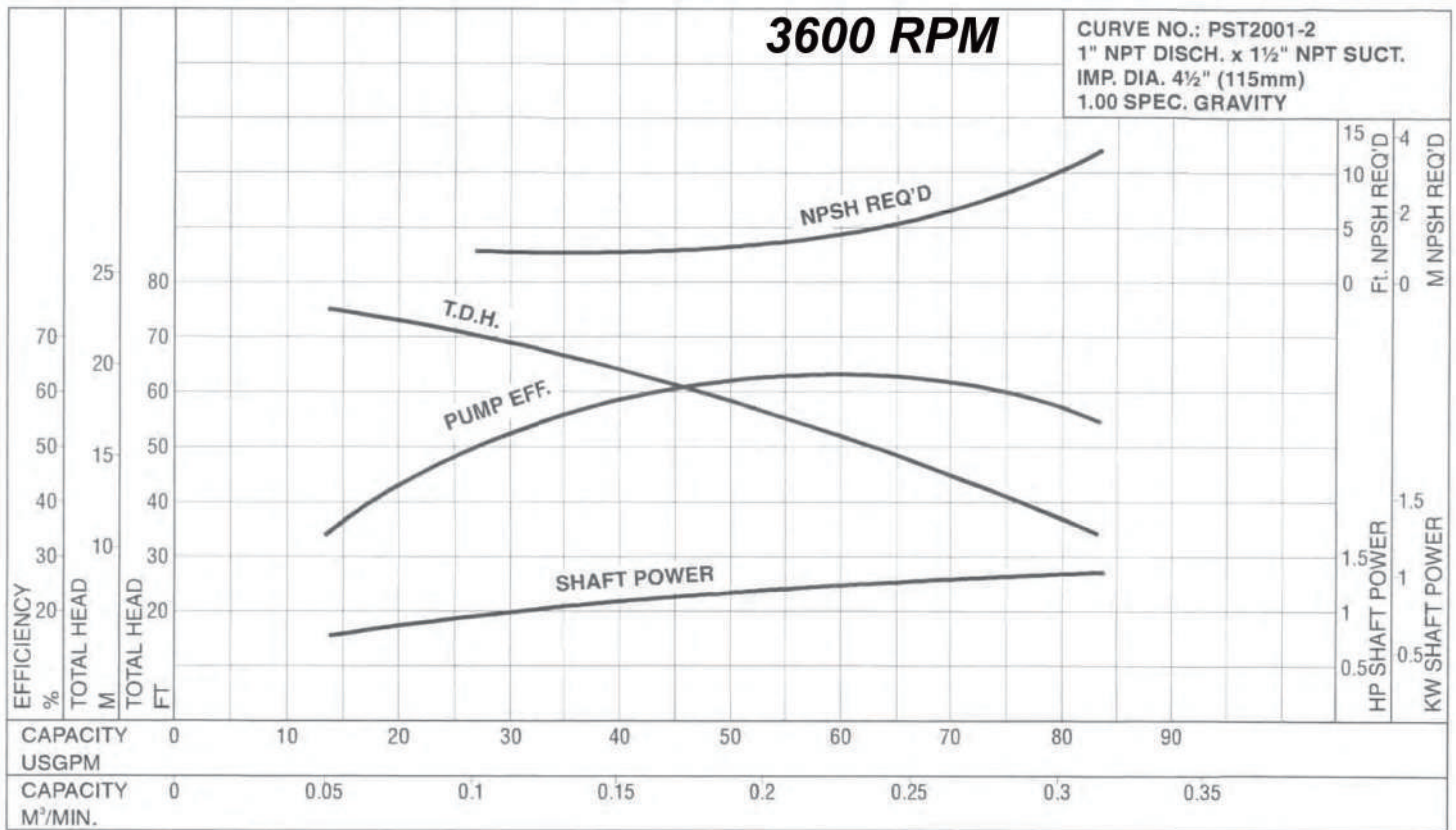



Series PS **MODEL PST2003**

CUSTOMER _____ REFERENCE _____

FLUID _____ S.G. _____ TEMP _____ CAPACITY _____ TDH _____

CERTIFIED: _____ DATE: _____

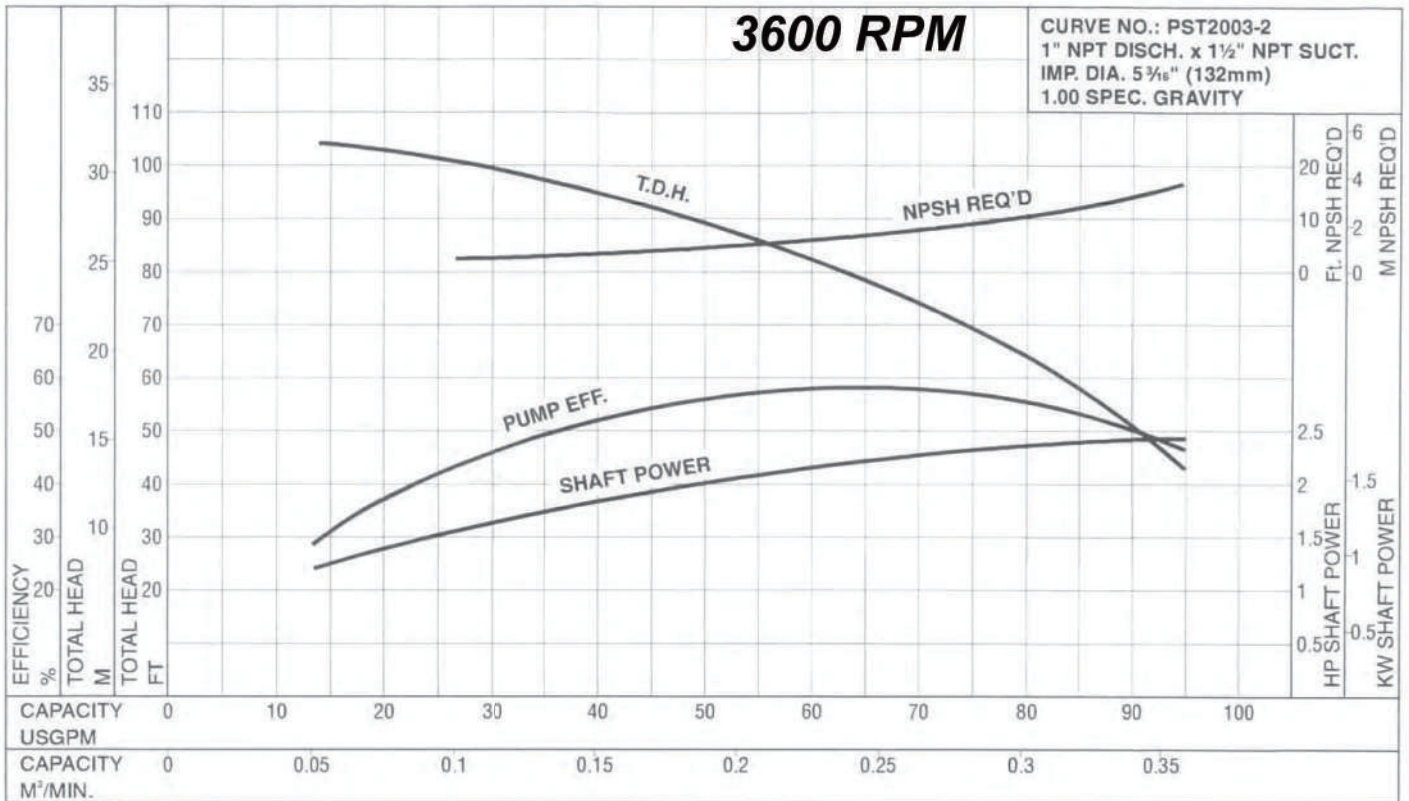



Series PS **MODEL PST2005**

CUSTOMER _____ REFERENCE _____

FLUID _____ S.G. _____ TEMP _____ CAPACITY _____ TDH _____

CERTIFIED: _____ DATE: _____

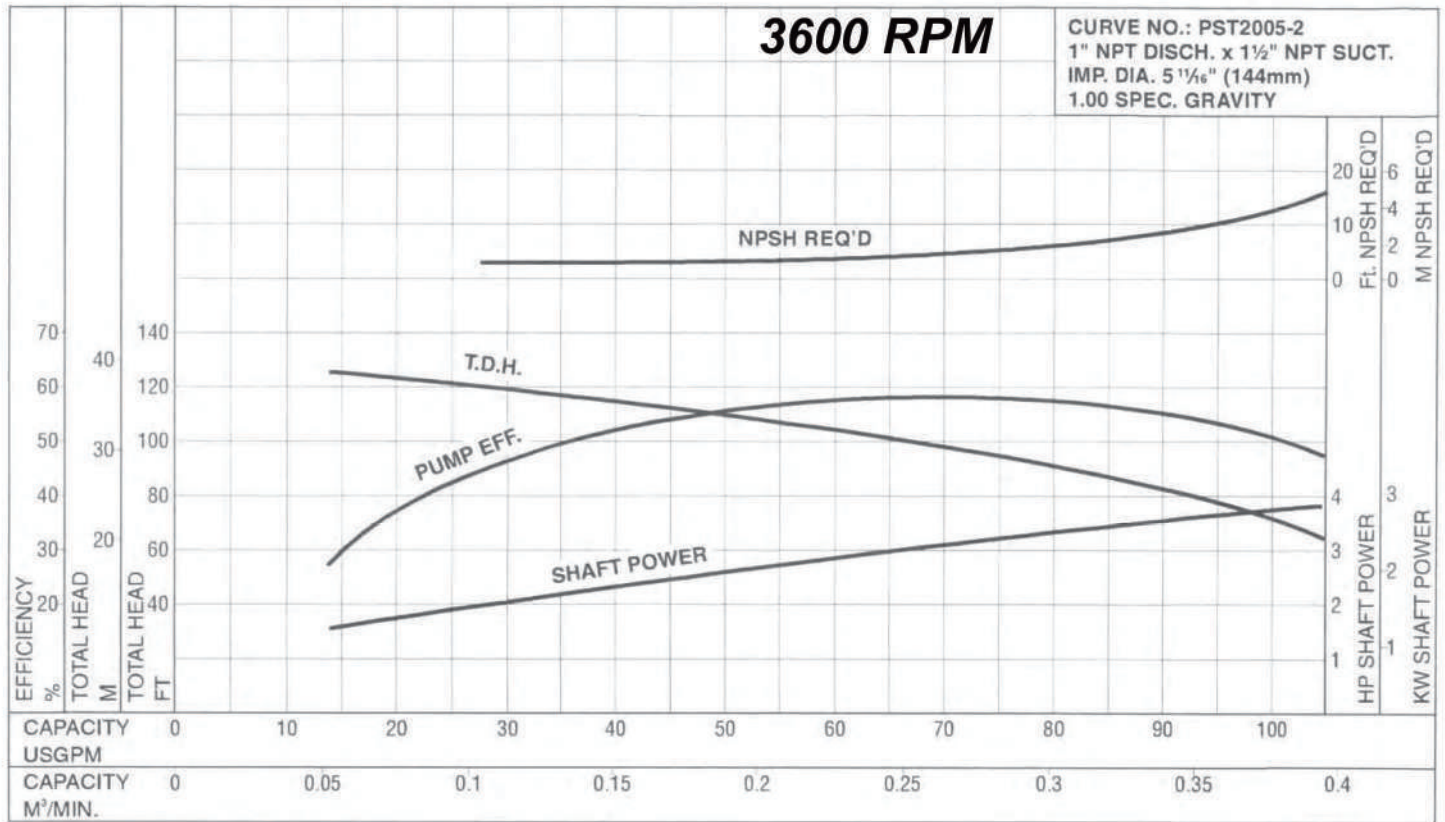



SERIES PS
Parts List
MODEL - PST701

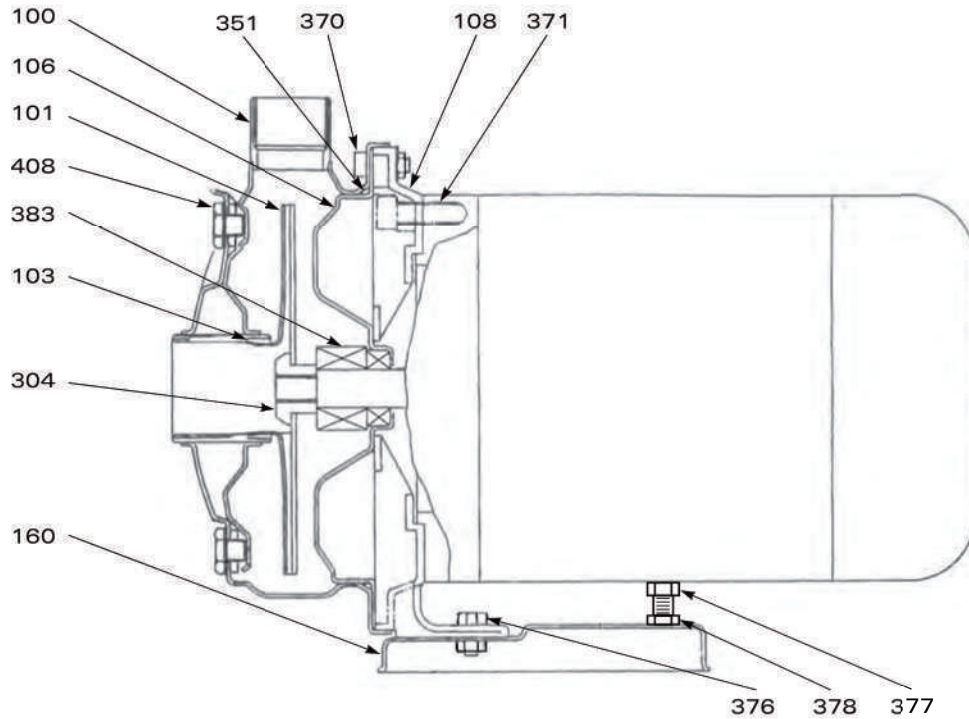

ITEM	QTY REQ'D	DESCRIPTION	MATERIAL	PART NUMBER
100	1	Casing	304 Stainless steel	E-251402230
101	1	Impeller	304 Stainless steel	E-251450785
103	1	Casing ring	Viton	E-255402064
106	1	Casing cover	304 Stainless steel	E-251438016
108	1	Adapter	Aluminum	E-340280085
160	1	Motor support	Steel	E-371472072
304	1	Impeller nut	304 Stainless steel	E-363396101
351	1	Casing o-ring	Viton (standard)	E-165X3V
			Buna (optional)	E-165X3B
370	8	Casing bolt	304 Stainless steel	E-M6X16HH
371	4	Motor bolt	Steel	E-3/8-16X3/4SH
376	2	Foot bolt	Steel	E-M8X16HH
377	1	Support bolt	Steel	E-M8X45HH
378	1	Support bolt nut	Steel	E-M8HN
383	1	Mechanical seal	Carbon/Ceramic/Buna	S10-2021-ABN
			Carbon/Ceramic/Viton	S10-2021-AVT
			Carbon/S.S./EPR	S10-2021-CEP
			Carbon/Carbide/Viton	S10-2021-BVT
			Carbide/Carbide/Viton	S10-2021-EVT
408	2	Casing plug	304 Stainless steel	375132107



SERIES PS
Parts List
MODEL - PST703

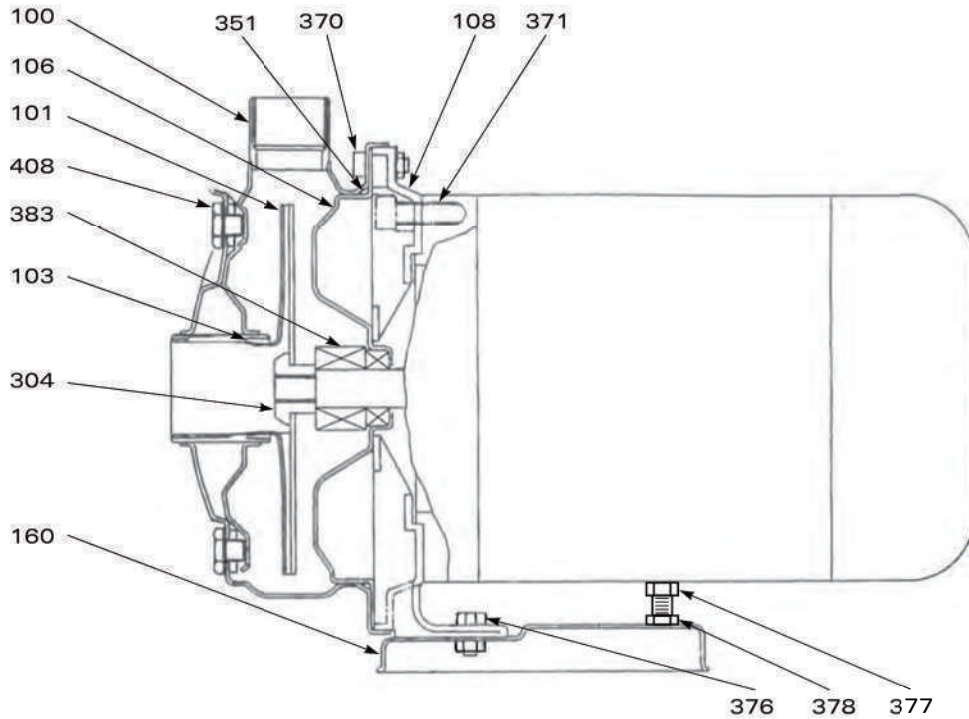

ITEM	QTY REQ'D	DESCRIPTION	MATERIAL	PART NUMBER
100	1	Casing	304 Stainless steel	E-251402230
101	1	Impeller	304 Stainless steel	E-251450786
103	1	Casing ring	Viton	E-255402064
106	1	Casing cover	304 Stainless steel	E-251438016
108	1	Adapter	Aluminum	E-340280085
160	1	Motor support	Steel	E-371472072
304	1	Impeller nut	304 Stainless steel	E-363396101
351	1	Casing o-ring	Viton (standard)	E-165X3V
			Buna (optional)	E-165X3B
370	8	Casing bolt	304 Stainless steel	E-M6X16HH
371	4	Motor bolt	Steel	E-3/8-16X3/4SH
376	2	Foot bolt	Steel	E-M8X16HH
377	1	Support bolt	Steel	E-M8X45HH
378	1	Support bolt nut	Steel	E-M8HN
383	1	Mechanical seal	Carbon/Ceramic/Buna	S10-2021-ABN
			Carbon/Ceramic/Viton	S10-2021-AVT
			Carbon/S.S./EPR	S10-2021-CEP
			Carbon/Carbide/Viton	S10-2021-BVT
			Carbide/Carbide/Viton	S10-2021-EVT
408	2	Casing plug	304 Stainless steel	375132107



SERIES PS
Parts List
MODEL - PST705

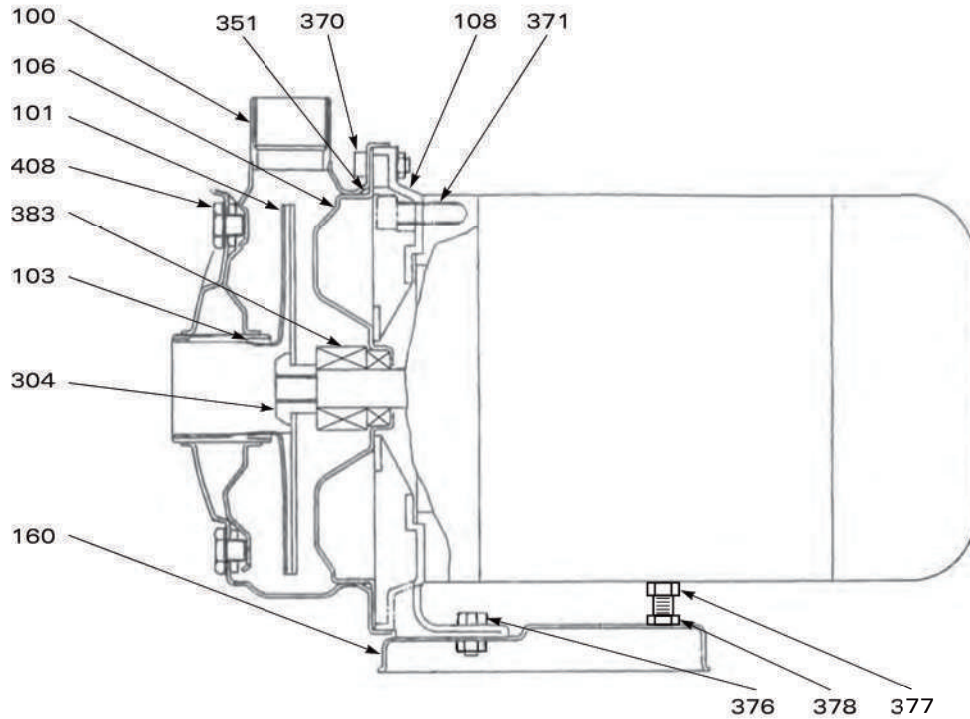

ITEM	QTY REQ'D	DESCRIPTION	MATERIAL	PART NUMBER
100	1	Casing	304 Stainless steel	E-251402230
101	1	Impeller	304 Stainless steel	E-251450787
103	1	Casing ring	Viton	E-255402064
106	1	Casing cover	304 Stainless steel	E-251438016
108	1	Adapter	Aluminum	E-340280085
160	1	Motor support	Steel	E-371472072
304	1	Impeller nut	304 Stainless steel	E-363396101
351	1	Casing o-ring	Viton (standard)	E-165X3V
			Buna (optional)	E-165X3B
370	8	Casing bolt	304 Stainless steel	E-M6X16HH
371	4	Motor bolt	Steel	E-3/8-16X3/4SH
376	2	Foot bolt	Steel	E-M8X16HH
377	1	Support bolt	Steel	E-M8X45HH
378	1	Support bolt nut	Steel	E-M8HN
383	1	Mechanical seal	Carbon/Ceramic/Buna	S10-2021-ABN
			Carbon/Ceramic/Viton	S10-2021-AVT
			Carbon/S.S./EPR	S10-2021-CEP
			Carbon/Carbide/Viton	S10-2021-BVT
			Carbide/Carbide/Viton	S10-2021-EVT
408	2	Casing plug	304 Stainless steel	375132107



SERIES PS
Parts List
MODEL - PST1201

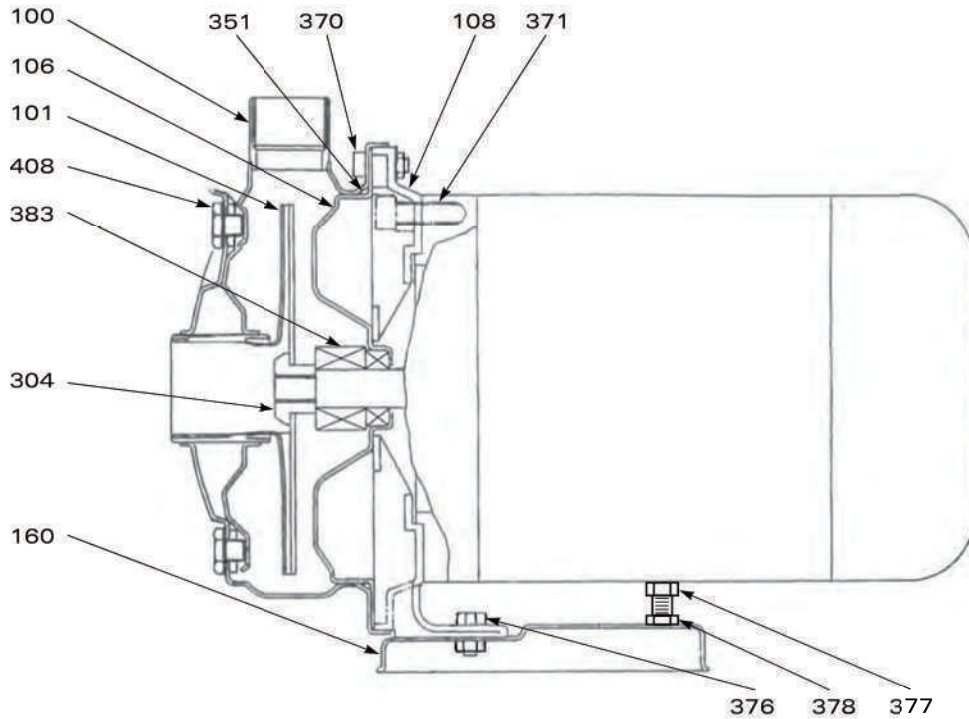

ITEM	QTY REQ'D	DESCRIPTION	MATERIAL	PART NUMBER
100	1	Casing	304 Stainless steel	E-251402231
101	1	Impeller	304 Stainless steel	E-251450788
106	1	Casing cover	304 Stainless steel	E-251438016
108	1	Adapter	Aluminum	E-340280085
160	1	Motor support	Steel	E-371472072
304	1	Impeller nut	304 Stainless steel	E-363396101
351	1	Casing o-ring	Viton (standard)	E-165X3V
			Buna (optional)	E-165X3B
370	8	Casing bolt	304 Stainless steel	E-M6X16HH
371	4	Motor bolt	Steel	E-3/8-16X3/4SH
376	2	Foot bolt	Steel	E-M8X16HH
377	1	Support bolt	Steel	E-M8X45HH
378	1	Support bolt nut	Steel	E-M8HN
383	1	Mechanical seal	Carbon/Ceramic/Buna	S10-2021-ABN
			Carbon/Ceramic/Viton	S10-2021-AVT
			Carbon/S.S./EPR	S10-2021-CEP
			Carbon/Carbide/Viton	S10-2021-BVT
			Carbide/Carbide/Viton	S10-2021-EVT
408	2	Casing plug	304 Stainless steel	375132107



SERIES PS
Parts List
MODEL - PST1203

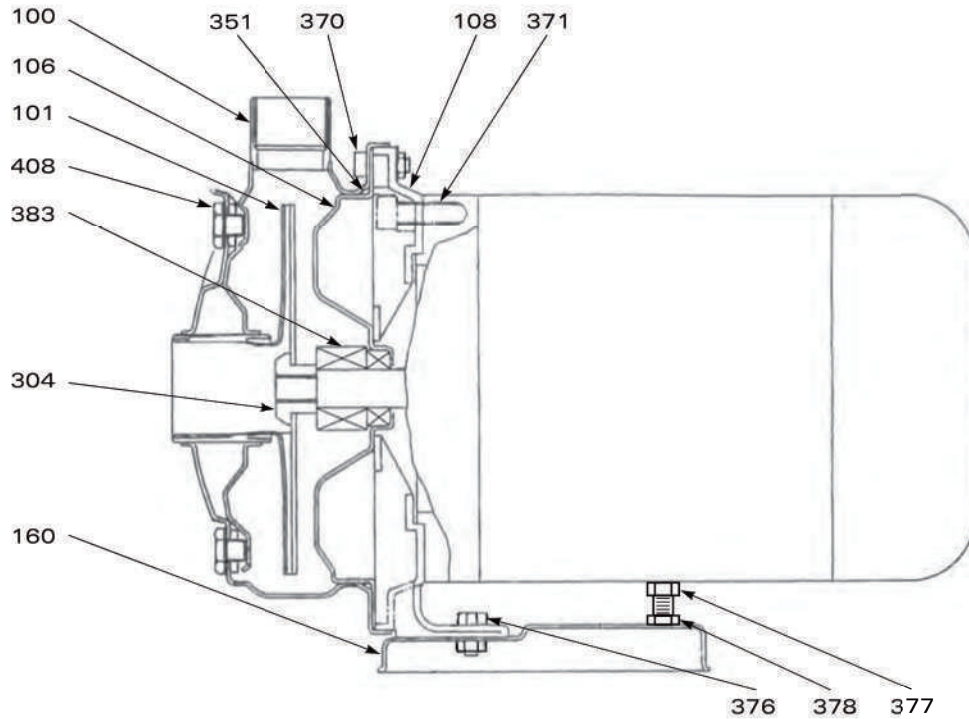

ITEM	QTY REQ'D	DESCRIPTION	MATERIAL	PART NUMBER
100	1	Casing	304 Stainless steel	E-251402231
101	1	Impeller	304 Stainless steel	E-251450789
106	1	Casing cover	304 Stainless steel	E-251438016
108	1	Adapter	Aluminum	E-340280085
160	1	Motor support	Steel	E-371472072
304	1	Impeller nut	304 Stainless steel	E-363396101
351	1	Casing o-ring	Viton (standard)	E-165X3V
			Buna (optional)	E-165X3B
370	8	Casing bolt	304 Stainless steel	E-M6X16HH
371	4	Motor bolt	Steel	E-3/8-16X3/4SH
376	2	Foot bolt	Steel	E-M8X16HH
377	1	Support bolt	Steel	E-M8X45HH
378	1	Support bolt nut	Steel	E-M8HN
383	1	Mechanical seal	Carbon/Ceramic/Buna	S10-2021-ABN
			Carbon/Ceramic/Viton	S10-2021-AVT
			Carbon/S.S./EPR	S10-2021-CEP
			Carbon/Carbide/Viton	S10-2021-BVT
			Carbide/Carbide/Viton	S10-2021-EVT
408	2	Casing plug	304 Stainless steel	375132107



SERIES PS
Parts List
MODEL - PST1205

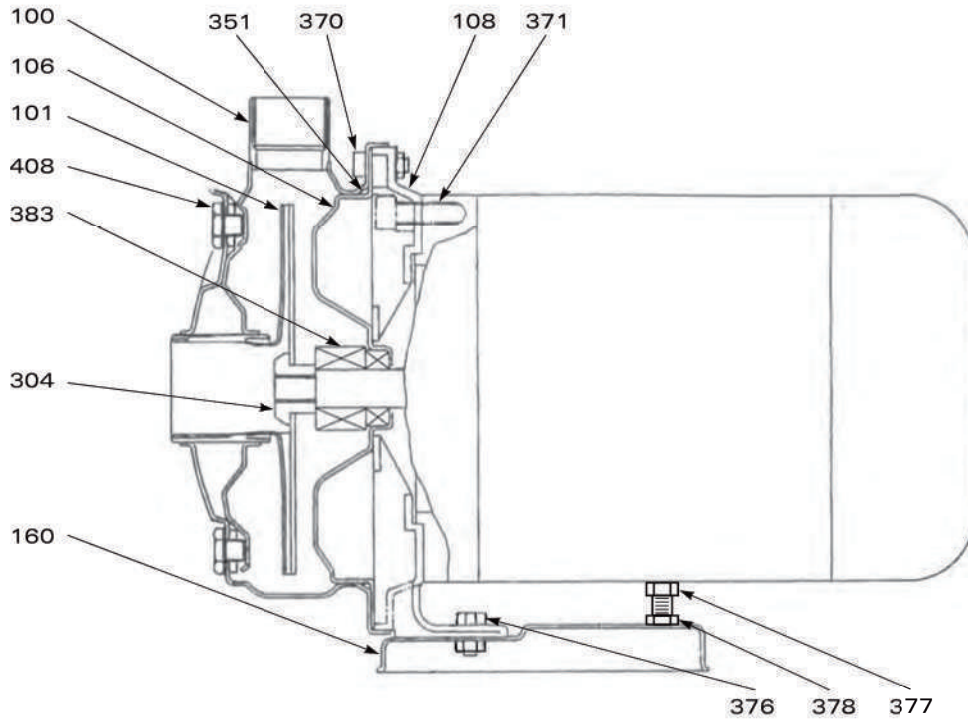

ITEM	QTY REQ'D	DESCRIPTION	MATERIAL	PART NUMBER
100	1	Casing	304 Stainless steel	E-251420086
101	1	Impeller	304 Stainless steel	E-251450790
106	1	Casing cover	304 Stainless steel	E-251438016
108	1	Adapter	Aluminum	E-340280085
160	1	Motor support	Steel	E-371472072
304	1	Impeller nut	304 Stainless steel	E-363396101
351	1	Casing o-ring	Viton (standard)	E-165X3V
			Buna (optional)	E-165X3B
370	8	Casing bolt	304 Stainless steel	E-M6X16HH
371	4	Motor bolt	Steel	E-3/8-16X3/4SH
376	2	Foot bolt	Steel	E-M8X16HH
377	1	Support bolt	Steel	E-M8X45HH
378	1	Support bolt nut	Steel	E-M8HN
383	1	Mechanical seal	Carbon/Ceramic/Buna	S10-2021-ABN
			Carbon/Ceramic/Viton	S10-2021-AVT
			Carbon/S.S./EPR	S10-2021-CEP
			Carbon/Carbide/Viton	S10-2021-BVT
			Carbide/Carbide/Viton	S10-2021-EVT
408	2	Casing plug	304 Stainless steel	375132107



SERIES PS
Parts List
MODEL - PST2001

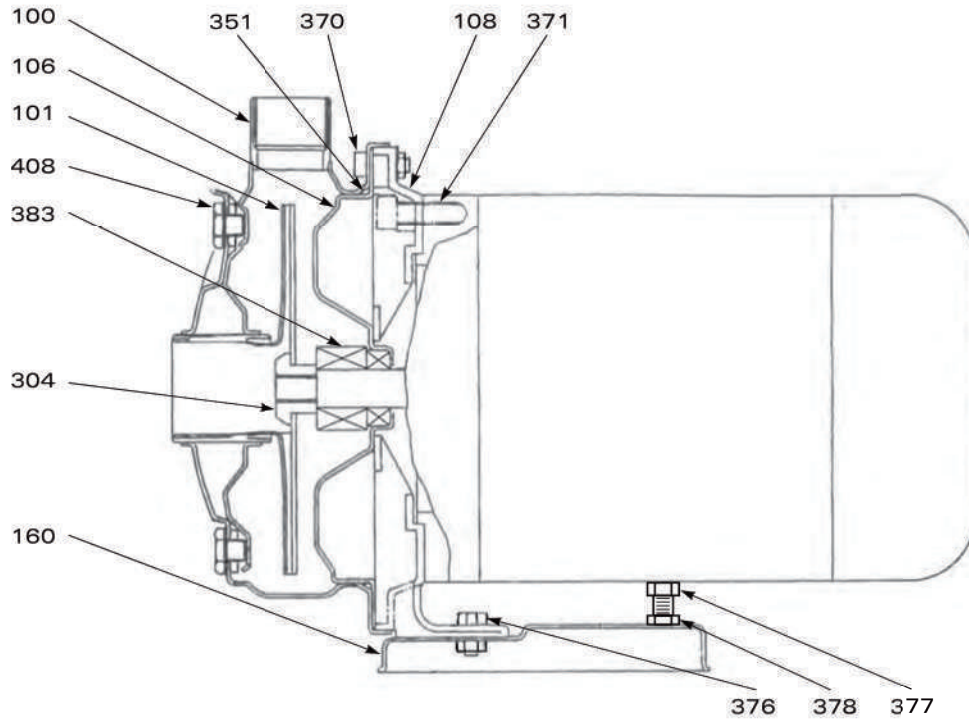

ITEM	QTY REQ'D	DESCRIPTION	MATERIAL	PART NUMBER
100	1	Casing	304 Stainless steel	E-251420087
101	1	Impeller	304 Stainless steel	E-251450791
106	1	Casing cover	304 Stainless steel	E-251438016
108	1	Adapter	Aluminum	E-340280085
160	1	Motor support	Steel	E-371472072
304	1	Impeller nut	304 Stainless steel	E-363396101
351	1	Casing o-ring	Viton (standard)	E-165X3V
			Buna (optional)	E-165X3B
370	8	Casing bolt	304 Stainless steel	E-M6X16HH
371	4	Motor bolt	Steel	E-3/8-16X3/4SH
376	2	Foot bolt	Steel	E-M8X16HH
377	1	Support bolt	Steel	E-M8X45HH
378	1	Support bolt nut	Steel	E-M8HN
383	1	Mechanical seal	Carbon/Ceramic/Buna	S10-2021-ABN
			Carbon/Ceramic/Viton	S10-2021-AVT
			Carbon/S.S./EPR	S10-2021-CEP
			Carbon/Carbide/Viton	S10-2021-BVT
			Carbide/Carbide/Viton	S10-2021-EVT
408	2	Casing plug	304 Stainless steel	375132107



SERIES PS
Parts List
MODEL - PST2003

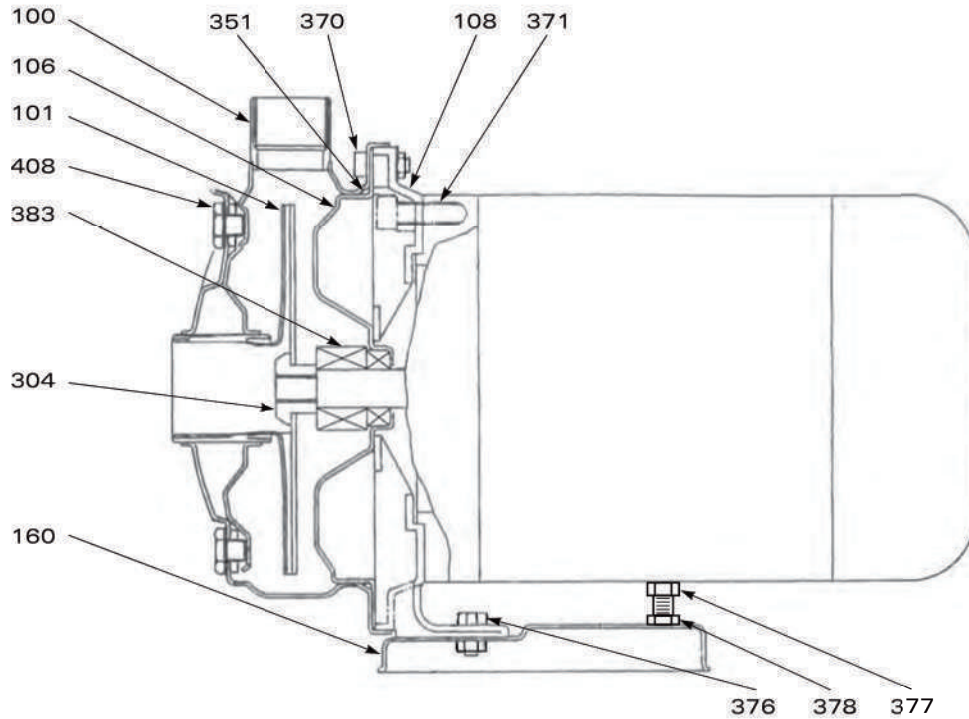

ITEM	QTY REQ'D	DESCRIPTION	MATERIAL	PART NUMBER
100	1	Casing	304 Stainless steel	E-251420087
101	1	Impeller	304 Stainless steel	E-251450792
106	1	Casing cover	304 Stainless steel	E-251438016
108	1	Adapter	Aluminum	E-340280085
160	1	Motor support	Steel	E-371472072
304	1	Impeller nut	304 Stainless steel	E-363396101
351	1	Casing o-ring	Viton (standard)	E-165X3V
			Buna (optional)	E-165X3B
370	8	Casing bolt	304 Stainless steel	E-M6X16HH
371	4	Motor bolt	Steel	E-3/8-16X3/4SH
376	2	Foot bolt	Steel	E-M8X16HH
377	1	Support bolt	Steel	E-M8X45HH
378	1	Support bolt nut	Steel	E-M8HN
383	1	Mechanical seal	Carbon/Ceramic/Buna	S10-2021-ABN
			Carbon/Ceramic/Viton	S10-2021-AVT
			Carbon/S.S./EPR	S10-2021-CEP
			Carbon/Carbide/Viton	S10-2021-BVT
			Carbide/Carbide/Viton	S10-2021-EVT
408	2	Casing plug	304 Stainless steel	375132107



SERIES PS Parts List MODEL - PST2005

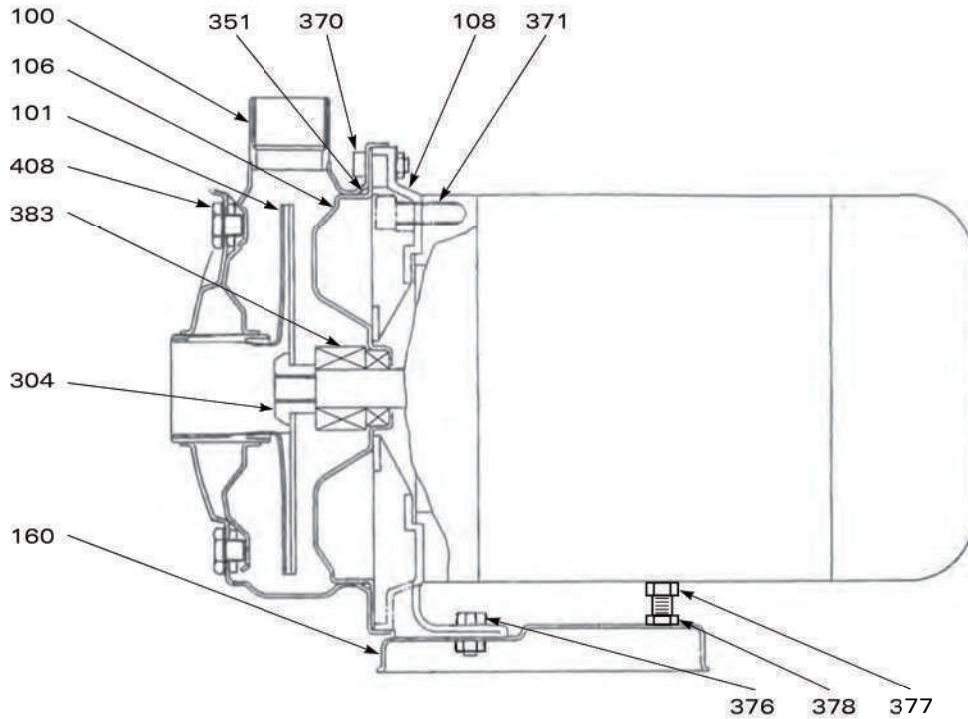

ITEM	QTY REQ'D	DESCRIPTION	MATERIAL	PART NUMBER
100	1	Casing	304 Stainless steel	E-251420087
101	1	Impeller	304 Stainless steel	E-251450793
106	1	Casing cover	304 Stainless steel	E-251438016
108	1	Adapter	Aluminum	E-340280085
160	1	Motor support	Steel	E-371472072
304	1	Impeller nut	304 Stainless steel	E-363396101
351	1	Casing o-ring	Viton (standard)	E-165X3V
			Buna (optional)	E-165X3B
370	8	Casing bolt	304 Stainless steel	E-M6X16HH
371	4	Motor bolt	Steel	E-3/8-16X3/4SH
376	2	Foot bolt	Steel	E-M8X16HH
377	1	Support bolt	Steel	E-M8X45HH
378	1	Support bolt nut	Steel	E-M8HN
383	1	Mechanical seal	Carbon/Ceramic/Buna	S10-2021-ABN
			Carbon/Ceramic/Viton	S10-2021-AVT
			Carbon/S.S./EPR	S10-2021-CEP
			Carbon/Carbide/Viton	S10-2021-BVT
			Carbide/Carbide/Viton	S10-2021-EVT
408	2	Casing plug	304 Stainless steel	375132107



SERIES PS

Dimensional Outline

MODEL - PST

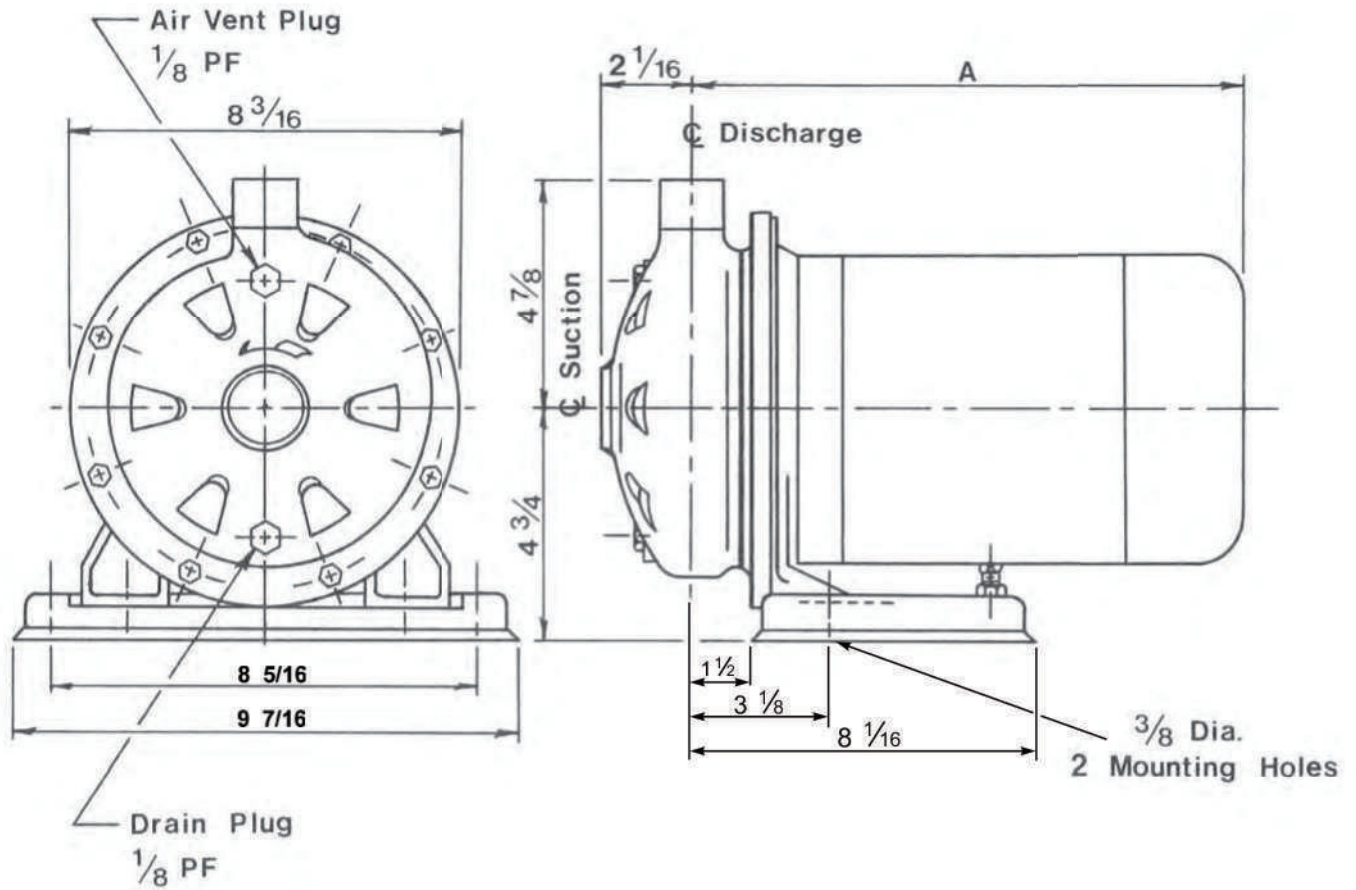

Inches

Model	Size	Pump Size - NPT (in)		A (max.)	Unit Weight (lbs)			
		Suction	Discharge		Single Phase		Three Phase	
					ODP	TEFC	ODP	TEFC
701 $\frac{3}{4}$ HP	1 x $1 \frac{1}{4}$ - $4 \frac{1}{2}$	$\frac{1}{4}$	1	$13 \frac{1}{8}$	36	41	31	31
703 $1 \frac{1}{2}$ HP	1 x $1 \frac{1}{4}$ - $5 \frac{3}{16}$	$\frac{1}{4}$	1	$13 \frac{9}{16}$	47	50	39	39
705 2HP	1 x $1 \frac{1}{4}$ - $6 \frac{3}{16}$	$\frac{1}{4}$	1	$14 \frac{7}{16}$	51	58	44	48
1201 1HP	1 x $1 \frac{1}{4}$ - $4 \frac{1}{2}$	$\frac{1}{4}$	1	$13 \frac{9}{16}$	41	46	33	32
1203 $1 \frac{1}{2}$ HP	1 x $1 \frac{1}{4}$ - $5 \frac{3}{16}$	$\frac{1}{4}$	1	$13 \frac{9}{16}$	47	50	39	39
1205 3HP	1 x $1 \frac{1}{4}$ - $6 \frac{3}{16}$	$\frac{1}{4}$	1	$14 \frac{7}{16}$	59	66	51	60
2001 $1 \frac{1}{2}$ HP	1 x $1 \frac{1}{2}$ - $4 \frac{1}{2}$	$\frac{1}{2}$	1	$13 \frac{9}{16}$	47	50	39	39
2003 3HP	1 x $1 \frac{1}{2}$ - $5 \frac{3}{16}$	$\frac{1}{2}$	1	$14 \frac{7}{16}$	58	65	50	59
2005 3HP	1 x $1 \frac{1}{2}$ - $5 \frac{1}{16}$	$\frac{1}{2}$	1	$14 \frac{7}{16}$	58	65	50	59

NOT FOR CONSTRUCTION PURPOSES UNLESS CERTIFIED.



**SERIES PS - DIMENSIONAL OUTLINE
MODEL - PST701**

CUSTOMER - _____
 CUSTOMER REF. - _____ OUR REF. - _____
 HP - _____ RPM - _____ VOLTAGE - _____ ENCL. - _____

CERTIFIED - _____ DATE - _____

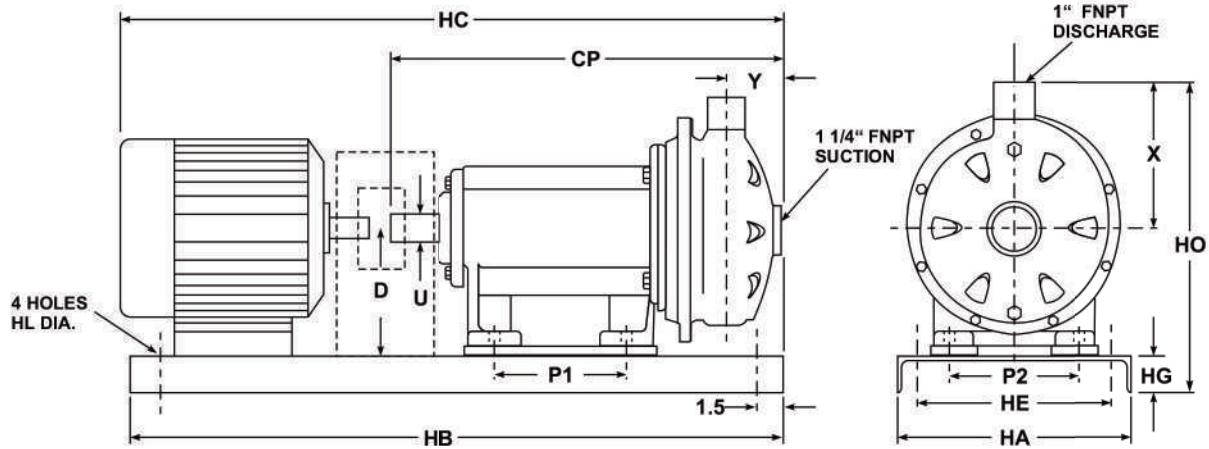

MOTOR FRAME	DIMENSIONS														WEIGHT (lbs)*		
	HA	HB	HL	HC*	HO	HG	HE	CP	P1	P2	D**	U	X	Y	PUMP	MOTOR	ASS'Y
56	10	30	0.62	23	11.75	2.62	7.0	12.12	4.25	5.5	3.68	0.75	4.88	2.06	25	30	95
143T	10	30	0.62	25	11.75	2.62	7.0	12.12	4.25	5.5	3.68	0.75	4.88	2.06	25	40	105
145T	10	30	0.62	26	11.75	2.62	7.0	12.12	4.25	5.5	3.68	0.75	4.88	2.06	25	50	115
182T	10	30	0.62	27	11.75	2.62	7.0	12.12	4.25	5.5	3.68	0.75	4.88	2.06	25	80	150
184T	10	30	0.62	28	11.75	2.62	7.0	12.12	4.25	5.5	3.68	0.75	4.88	2.06	25	90	160

- NOTES - Not for construction purposes unless certified above.
 - All dimensions in inches.
 - Some dimensions may vary +/- 0.25 inches.
 - * Approximate only.
 - ** Shaft centerline to underside of pump feet.



**SERIES PS - DIMENSIONAL OUTLINE
MODEL - PST703**

CUSTOMER - _____
 CUSTOMER REF. - _____ OUR REF. - _____
 HP - _____ RPM - _____ VOLTAGE - _____ ENCL. - _____

CERTIFIED - _____ DATE - _____

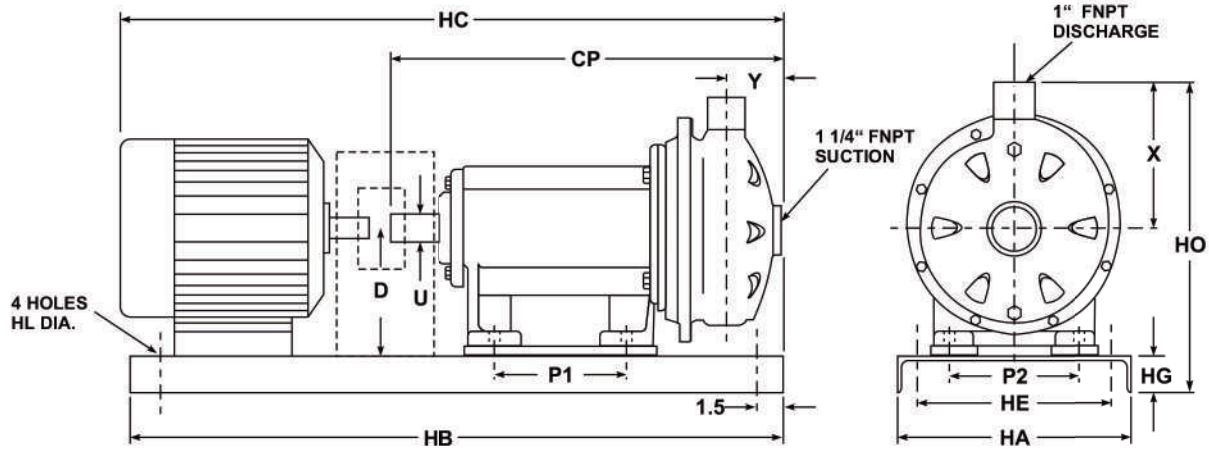

MOTOR FRAME	DIMENSIONS														WEIGHT (lbs)*		
	HA	HB	HL	HC*	HO	HG	HE	CP	P1	P2	D**	U	X	Y	PUMP	MOTOR	ASS'Y
56	10	30	0.62	23	11.75	2.62	7.0	12.12	4.25	5.5	3.68	0.75	4.88	2.06	25	30	95
143T	10	30	0.62	25	11.75	2.62	7.0	12.12	4.25	5.5	3.68	0.75	4.88	2.06	25	40	105
145T	10	30	0.62	26	11.75	2.62	7.0	12.12	4.25	5.5	3.68	0.75	4.88	2.06	25	50	115
182T	10	30	0.62	27	11.75	2.62	7.0	12.12	4.25	5.5	3.68	0.75	4.88	2.06	25	80	150
184T	10	30	0.62	28	11.75	2.62	7.0	12.12	4.25	5.5	3.68	0.75	4.88	2.06	25	90	160

- NOTES - Not for construction purposes unless certified above.
 - All dimensions in inches.
 - Some dimensions may vary +/- 0.25 inches.
 - * Approximate only.
 - ** Shaft centerline to underside of pump feet.



**SERIES PS - DIMENSIONAL OUTLINE
MODEL - PST705**

CUSTOMER - _____
 CUSTOMER REF. - _____ OUR REF. - _____
 HP - _____ RPM - _____ VOLTAGE - _____ ENCL. - _____

CERTIFIED - _____ DATE - _____

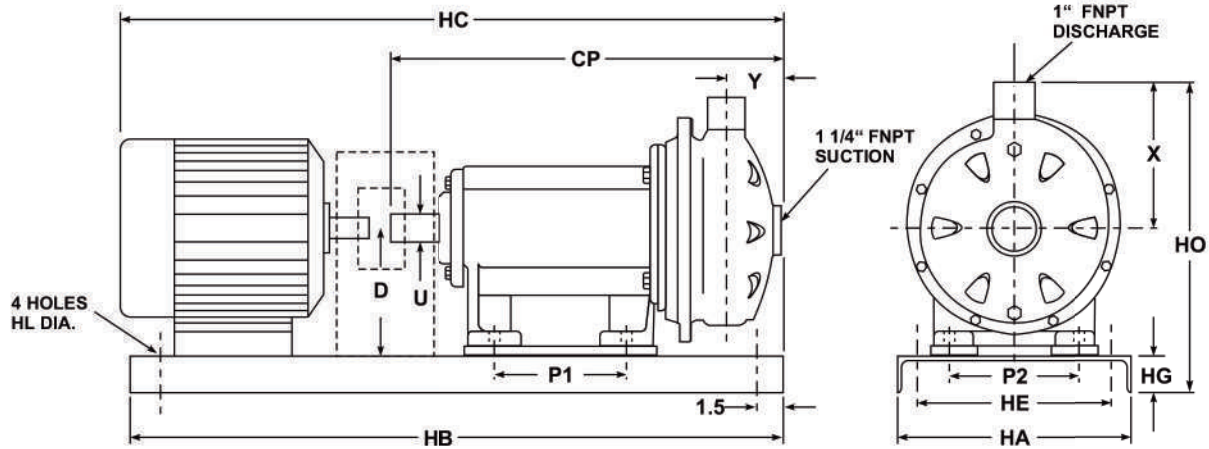

MOTOR FRAME	DIMENSIONS														WEIGHT (lbs)*		
	HA	HB	HL	HC*	HO	HG	HE	CP	P1	P2	D**	U	X	Y	PUMP	MOTOR	ASS'Y
56	10	30	0.62	23	11.75	2.62	7.0	12.12	4.25	5.5	3.68	0.75	4.88	2.06	25	30	95
143T	10	30	0.62	25	11.75	2.62	7.0	12.12	4.25	5.5	3.68	0.75	4.88	2.06	25	40	105
145T	10	30	0.62	26	11.75	2.62	7.0	12.12	4.25	5.5	3.68	0.75	4.88	2.06	25	50	115
182T	10	30	0.62	27	11.75	2.62	7.0	12.12	4.25	5.5	3.68	0.75	4.88	2.06	25	80	150
184T	10	30	0.62	28	11.75	2.62	7.0	12.12	4.25	5.5	3.68	0.75	4.88	2.06	25	90	160

- NOTES - Not for construction purposes unless certified above.
 - All dimensions in inches.
 - Some dimensions may vary +/- 0.25 inches.
 - * Approximate only.
 - ** Shaft centerline to underside of pump feet.



**SERIES PS - DIMENSIONAL OUTLINE
MODEL - PST1201**

CUSTOMER - _____
 CUSTOMER REF. - _____ OUR REF. - _____
 HP - _____ RPM - _____ VOLTAGE - _____ ENCL. - _____

CERTIFIED - _____ DATE - _____

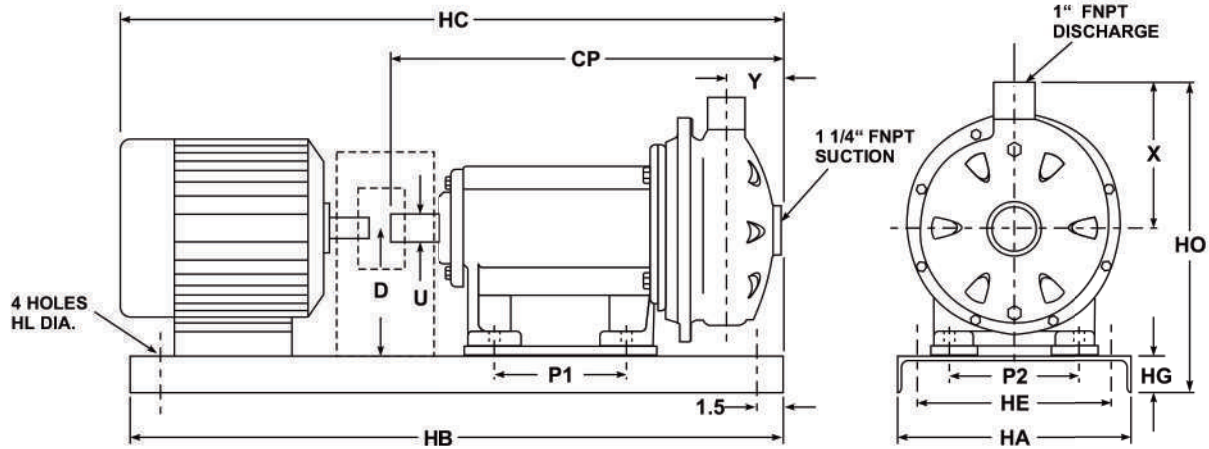

MOTOR FRAME	DIMENSIONS														WEIGHT (lbs)*		
	HA	HB	HL	HC*	HO	HG	HE	CP	P1	P2	D**	U	X	Y	PUMP	MOTOR	ASS'Y
56	10	30	0.62	23	11.75	2.62	7.0	12.12	4.25	5.5	3.68	0.75	4.88	2.06	25	30	95
143T	10	30	0.62	25	11.75	2.62	7.0	12.12	4.25	5.5	3.68	0.75	4.88	2.06	25	40	105
145T	10	30	0.62	26	11.75	2.62	7.0	12.12	4.25	5.5	3.68	0.75	4.88	2.06	25	50	115
182T	10	30	0.62	27	11.75	2.62	7.0	12.12	4.25	5.5	3.68	0.75	4.88	2.06	25	80	150
184T	10	30	0.62	28	11.75	2.62	7.0	12.12	4.25	5.5	3.68	0.75	4.88	2.06	25	90	160

- NOTES - Not for construction purposes unless certified above.
 - All dimensions in inches.
 - Some dimensions may vary +/- 0.25 inches.
 - * Approximate only.
 - ** Shaft centerline to underside of pump feet.



**SERIES PS - DIMENSIONAL OUTLINE
MODEL - PST1203**

CUSTOMER - _____
 CUSTOMER REF. - _____ OUR REF. - _____
 HP - _____ RPM - _____ VOLTAGE - _____ ENCL. - _____

CERTIFIED - _____ DATE - _____

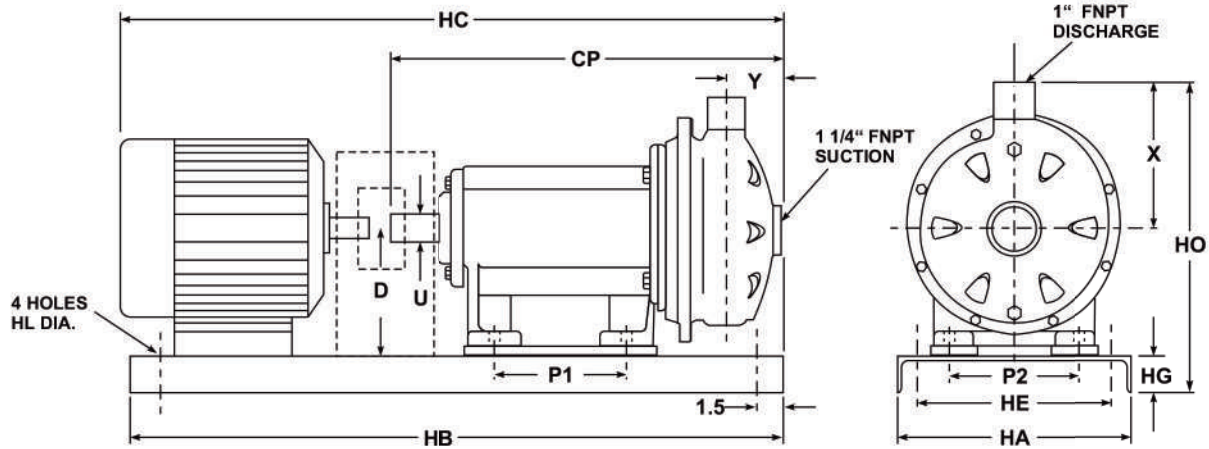

MOTOR FRAME	DIMENSIONS														WEIGHT (lbs)*		
	HA	HB	HL	HC*	HO	HG	HE	CP	P1	P2	D**	U	X	Y	PUMP	MOTOR	ASS'Y
56	10	30	0.62	23	11.75	2.62	7.0	12.12	4.25	5.5	3.68	0.75	4.88	2.06	25	30	95
143T	10	30	0.62	25	11.75	2.62	7.0	12.12	4.25	5.5	3.68	0.75	4.88	2.06	25	40	105
145T	10	30	0.62	26	11.75	2.62	7.0	12.12	4.25	5.5	3.68	0.75	4.88	2.06	25	50	115
182T	10	30	0.62	27	11.75	2.62	7.0	12.12	4.25	5.5	3.68	0.75	4.88	2.06	25	80	150
184T	10	30	0.62	28	11.75	2.62	7.0	12.12	4.25	5.5	3.68	0.75	4.88	2.06	25	90	160

- NOTES - Not for construction purposes unless certified above.
 - All dimensions in inches.
 - Some dimensions may vary +/- 0.25 inches.
 - * Approximate only.
 - ** Shaft centerline to underside of pump feet.



**SERIES PS - DIMENSIONAL OUTLINE
MODEL - PST1205**

CUSTOMER - _____
 CUSTOMER REF. - _____ OUR REF. - _____
 HP - _____ RPM - _____ VOLTAGE - _____ ENCL. - _____

CERTIFIED - _____ DATE - _____

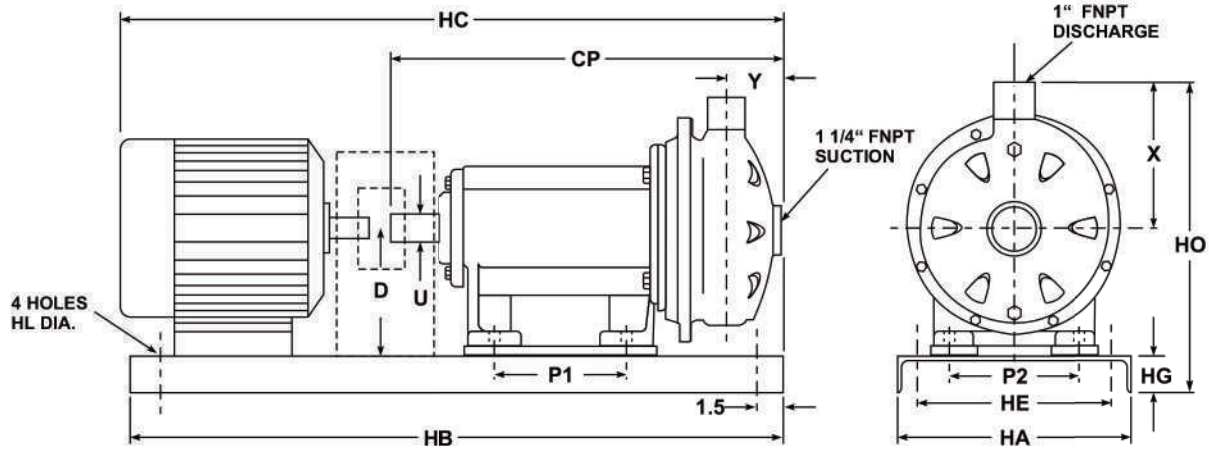

MOTOR FRAME	DIMENSIONS														WEIGHT (lbs)*		
	HA	HB	HL	HC*	HO	HG	HE	CP	P1	P2	D**	U	X	Y	PUMP	MOTOR	ASS'Y
56	10	30	0.62	23	11.75	2.62	7.0	12.12	4.25	5.5	3.68	0.75	4.88	2.06	25	30	95
143T	10	30	0.62	25	11.75	2.62	7.0	12.12	4.25	5.5	3.68	0.75	4.88	2.06	25	40	105
145T	10	30	0.62	26	11.75	2.62	7.0	12.12	4.25	5.5	3.68	0.75	4.88	2.06	25	50	115
182T	10	30	0.62	27	11.75	2.62	7.0	12.12	4.25	5.5	3.68	0.75	4.88	2.06	25	80	150
184T	10	30	0.62	28	11.75	2.62	7.0	12.12	4.25	5.5	3.68	0.75	4.88	2.06	25	90	160

- NOTES - Not for construction purposes unless certified above.
 - All dimensions in inches.
 - Some dimensions may vary +/- 0.25 inches.
 - * Approximate only.
 - ** Shaft centerline to underside of pump feet.



**SERIES PS - DIMENSIONAL OUTLINE
MODEL - PST2001**

CUSTOMER - _____
 CUSTOMER REF. - _____ OUR REF. - _____
 HP - _____ RPM - _____ VOLTAGE - _____ ENCL. - _____

CERTIFIED - _____ DATE - _____

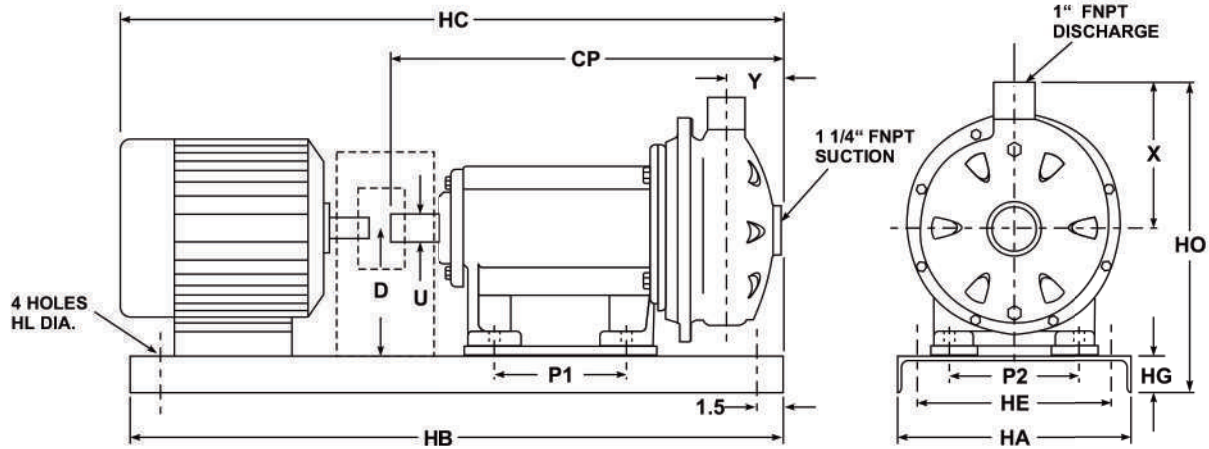

MOTOR FRAME	DIMENSIONS														WEIGHT (lbs)*		
	HA	HB	HL	HC*	HO	HG	HE	CP	P1	P2	D**	U	X	Y	PUMP	MOTOR	ASS'Y
56	10	30	0.62	23	11.75	2.62	7.0	12.12	4.25	5.5	3.68	0.75	4.88	2.06	25	30	95
143T	10	30	0.62	25	11.75	2.62	7.0	12.12	4.25	5.5	3.68	0.75	4.88	2.06	25	40	105
145T	10	30	0.62	26	11.75	2.62	7.0	12.12	4.25	5.5	3.68	0.75	4.88	2.06	25	50	115
182T	10	30	0.62	27	11.75	2.62	7.0	12.12	4.25	5.5	3.68	0.75	4.88	2.06	25	80	150
184T	10	30	0.62	28	11.75	2.62	7.0	12.12	4.25	5.5	3.68	0.75	4.88	2.06	25	90	160

- NOTES - Not for construction purposes unless certified above.
 - All dimensions in inches.
 - Some dimensions may vary +/- 0.25 inches.
 - * Approximate only.
 - ** Shaft centerline to underside of pump feet.



**SERIES PS - DIMENSIONAL OUTLINE
MODEL - PST2003**

CUSTOMER - _____
 CUSTOMER REF. - _____ OUR REF. - _____
 HP - _____ RPM - _____ VOLTAGE - _____ ENCL. - _____

CERTIFIED - _____ DATE - _____

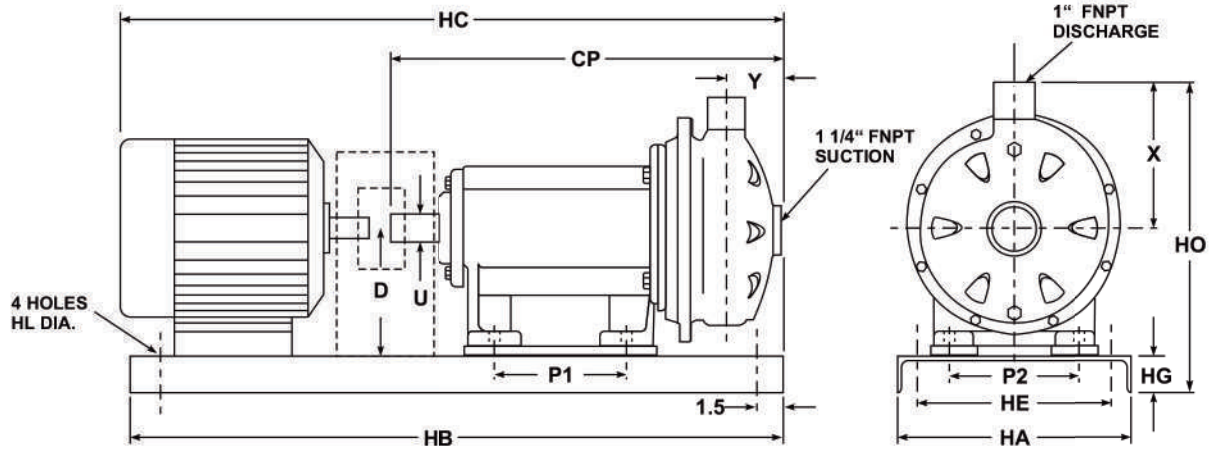

MOTOR FRAME	DIMENSIONS														WEIGHT (lbs)*		
	HA	HB	HL	HC*	HO	HG	HE	CP	P1	P2	D**	U	X	Y	PUMP	MOTOR	ASS'Y
56	10	30	0.62	23	11.75	2.62	7.0	12.12	4.25	5.5	3.68	0.75	4.88	2.06	25	30	95
143T	10	30	0.62	25	11.75	2.62	7.0	12.12	4.25	5.5	3.68	0.75	4.88	2.06	25	40	105
145T	10	30	0.62	26	11.75	2.62	7.0	12.12	4.25	5.5	3.68	0.75	4.88	2.06	25	50	115
182T	10	30	0.62	27	11.75	2.62	7.0	12.12	4.25	5.5	3.68	0.75	4.88	2.06	25	80	150
184T	10	30	0.62	28	11.75	2.62	7.0	12.12	4.25	5.5	3.68	0.75	4.88	2.06	25	90	160

- NOTES - Not for construction purposes unless certified above.
 - All dimensions in inches.
 - Some dimensions may vary +/- 0.25 inches.
 - * Approximate only.
 - ** Shaft centerline to underside of pump feet.



**SERIES PS - DIMENSIONAL OUTLINE
MODEL - PST2005**

CUSTOMER - _____
 CUSTOMER REF. - _____ OUR REF. - _____
 HP - _____ RPM - _____ VOLTAGE - _____ ENCL. - _____

CERTIFIED - _____ DATE - _____

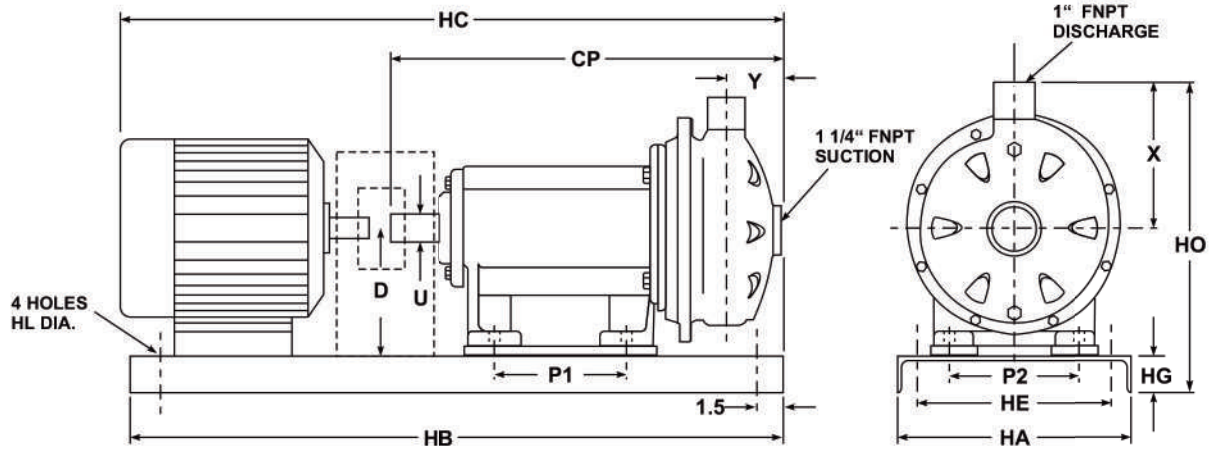

MOTOR FRAME	DIMENSIONS														WEIGHT (lbs)*		
	HA	HB	HL	HC*	HO	HG	HE	CP	P1	P2	D**	U	X	Y	PUMP	MOTOR	ASS'Y
56	10	30	0.62	23	11.75	2.62	7.0	12.12	4.25	5.5	3.68	0.75	4.88	2.06	25	30	95
143T	10	30	0.62	25	11.75	2.62	7.0	12.12	4.25	5.5	3.68	0.75	4.88	2.06	25	40	105
145T	10	30	0.62	26	11.75	2.62	7.0	12.12	4.25	5.5	3.68	0.75	4.88	2.06	25	50	115
182T	10	30	0.62	27	11.75	2.62	7.0	12.12	4.25	5.5	3.68	0.75	4.88	2.06	25	80	150
184T	10	30	0.62	28	11.75	2.62	7.0	12.12	4.25	5.5	3.68	0.75	4.88	2.06	25	90	160

- NOTES - Not for construction purposes unless certified above.
 - All dimensions in inches.
 - Some dimensions may vary +/- 0.25 inches.
 - * Approximate only.
 - ** Shaft centerline to underside of pump feet.



SERIES PS
Specifications
MODEL - PSF

	Standard	Optional
<p>Size</p> <p>Suction (150 lb. ANSI R.F. Equivalent)</p> <p>Discharge (150 lb. ANSI R.F. Equivalent)</p> <p>H.P. Range</p> <p>Performance Range</p> <p>Capacity Head</p> <p>Liquid Handling</p> <p>Liquid Type Temperature</p> <p>Working Pressure</p> <p>Materials</p> <p>Casing Impeller (Closed Type) Shaft Bracket Mechanical Seal</p> <p>Direction of Rotation</p> <p>Motor</p> <p>Type Speed Single Phase</p> <p>Three Phase</p>	<p>PSF70: 2" ANSI PSF120: 2½" ANSI PSF200: 2½" ANSI</p> <p>PSF70: 1¼" ANSI PSF120: 1½" ANSI PSF200: 2" ANSI</p> <p>1 H.P. to 15 H.P.</p> <p>13 to 380 GPM at 3450 R.P.M. 33 to 285 feet at 3450 R.P.M.</p> <p>Various Dependent on Mechanical Seal Selection Max. 145 P.S.I.G. (10 Bar)</p> <p>304 Stainless Steel 304 Stainless Steel Stainless Steel Cast Iron Carbon vs. Ceramic (Buna Elastomers)</p> <p>Clockwise when viewed from motor end</p> <p>NEMA JM Frame 60Hz 3450 RPM (2 poles) TEFC: 1 H.P. to 10 H.P. ODP: 1 H.P. to 10 H.P. 115/208-230V</p> <p>TEFC: 1 H.P. to 15 H.P. ODP: 1 H.P. to 15 H.P. 208-230/460V and 575V</p>	<p>Various material options for high temperature, corrosive, and abrasive services.</p> <p>•Explosion Proof •1750 RPM for lower flows and pressures</p>



SERIES PS
 Cross Section
MODEL - PSF
 Close-coupled

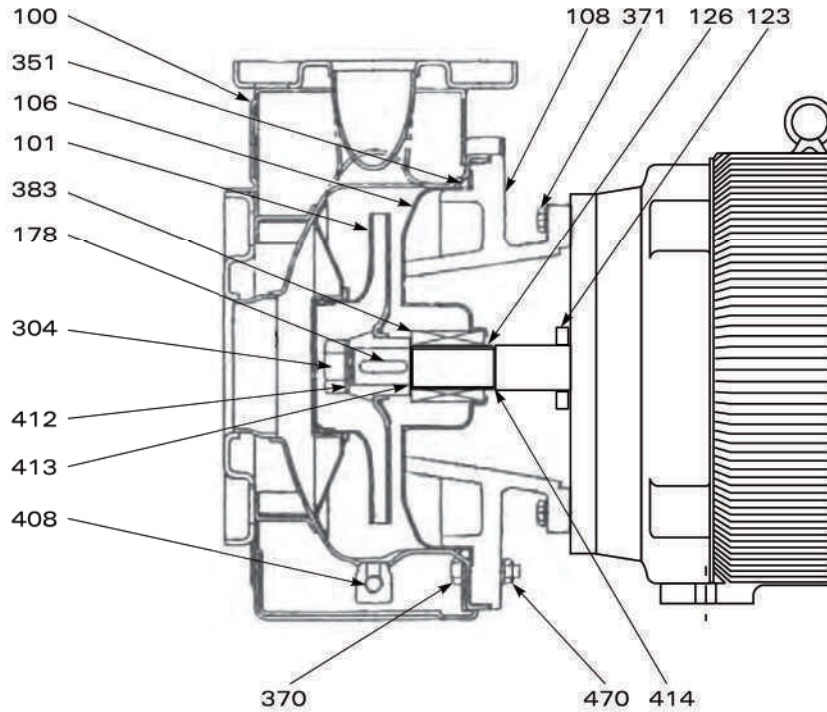

ITEM	QTY REQ'D	DESCRIPTION	MATERIAL
100	1	Casing	304 Stainless steel
101	1	Impeller	304 Stainless steel
106	1	Casing cover	304 Stainless steel
108	1	Adapter	Cast Iron
123	1	Slinger	Rubber
126	1	Shaft sleeve	304 Stainless steel
178	1	Impeller key	Steel
304	1	Impeller bolt	316 SS
351	1	Casing o-ring	Buna (standard)
370	*	Casing bolt	304 Stainless steel
371	4	Motor bolt	Steel
383	1	Mechanical seal	Various
408	1	Casing plug	304 Stainless steel
412	1	Impeller gasket	Teflon
413	1	Sleeve gasket	Teflon
414	1	Sleeve gasket	Teflon
470	*	Casing bolt nut	304 Stainless Steel

* Dependent on pump model



SERIES PS Cross Section MODEL - PSF Frame mounted

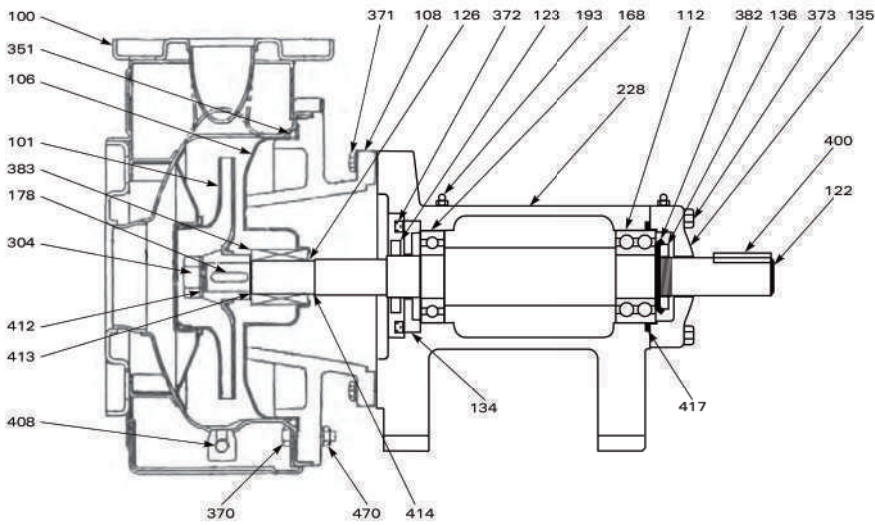

ITEM	QTY REQ'D	DESCRIPTION	MATERIAL
100	1	Casing	304 Stainless steel
101	1	Impeller	304 Stainless steel
106	1	Casing cover	304 Stainless steel
108	1	Adapter	Cast Iron
112	1	Thrust bearing	Steel
122	1	Shaft	Steel
123	1	Slinger	Rubber
126	1	Shaft sleeve	304 Stainless steel
134	1	Inboard brg cap	Steel
135	1	Outboard brg cap	Cast Iron
136	1	Brg lock nut	Steel
168	1	Radial bearing	Steel
178	1	Impeller key	304 Stainless steel
193	2	Grease fitting	Steel
228	1	Bearing frame	Cast Iron
304	1	Impeller bolt	304 Stainless steel
351	1	Casing o-ring	Buna (standard)
370	*	Casing bolt	304 Stainless steel
371	4	Frame bolt	Steel
372	4	Inboard cap bolt	Steel
373	4	Outboard cap bolt	Steel
382	1	Brg lock washer	Steel
383	1	Mechanical seal	Various
400	1	Shaft key	Steel
408	1	Casing plug	304 Stainless steel
412	1	Impeller gasket	Teflon
413	1	Sleeve gasket	Teflon
414	1	Sleeve gasket	Teflon
417	1	Retaining ring	Steel
470	*	Casing bolt nut	304 Stainless steel

* Dependent on pump model

FORM - PS00380
January 03



SERIES PS Specifications MODEL - PSF

Model PSF Selection Chart (1725 RPM)

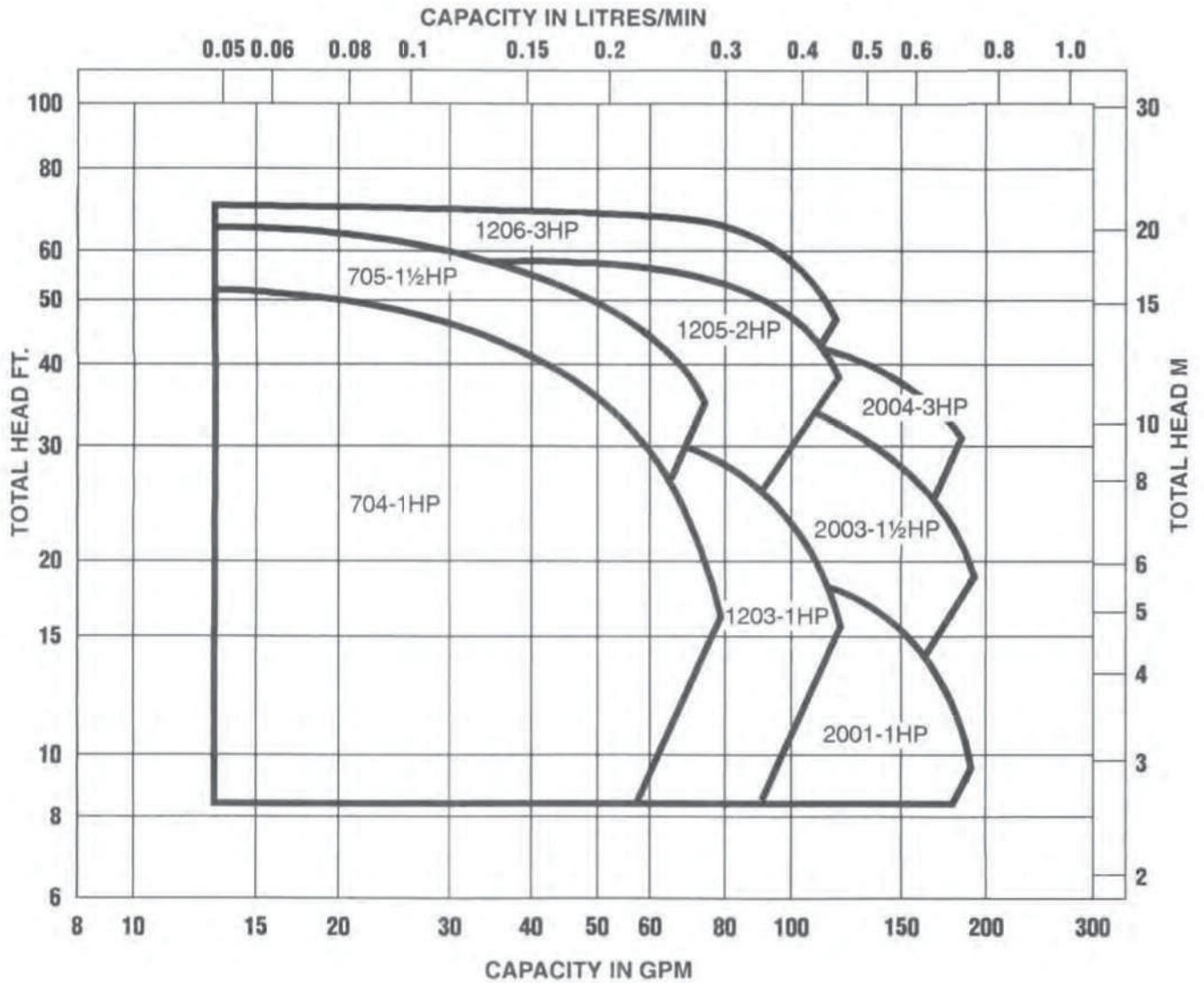



Series PS **MODEL PSF704**

CUSTOMER _____ REFERENCE _____

FLUID _____ S.G. _____ TEMP _____ CAPACITY _____ TDH _____

CERTIFIED: _____ DATE: _____

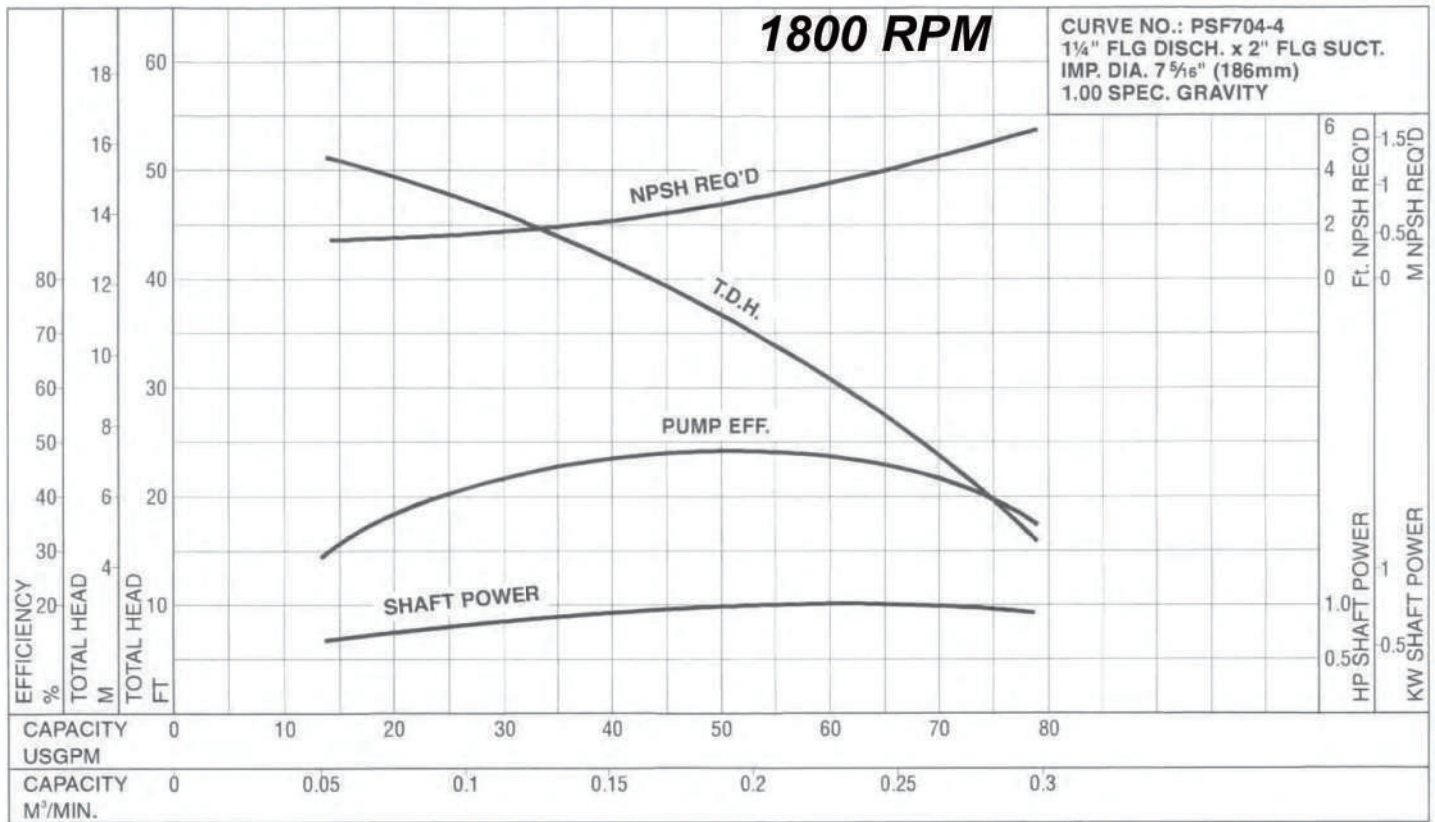



Series PS **MODEL PSF705**

CUSTOMER _____ REFERENCE _____

FLUID _____ S.G. _____ TEMP _____ CAPACITY _____ TDH _____

CERTIFIED: _____ DATE: _____

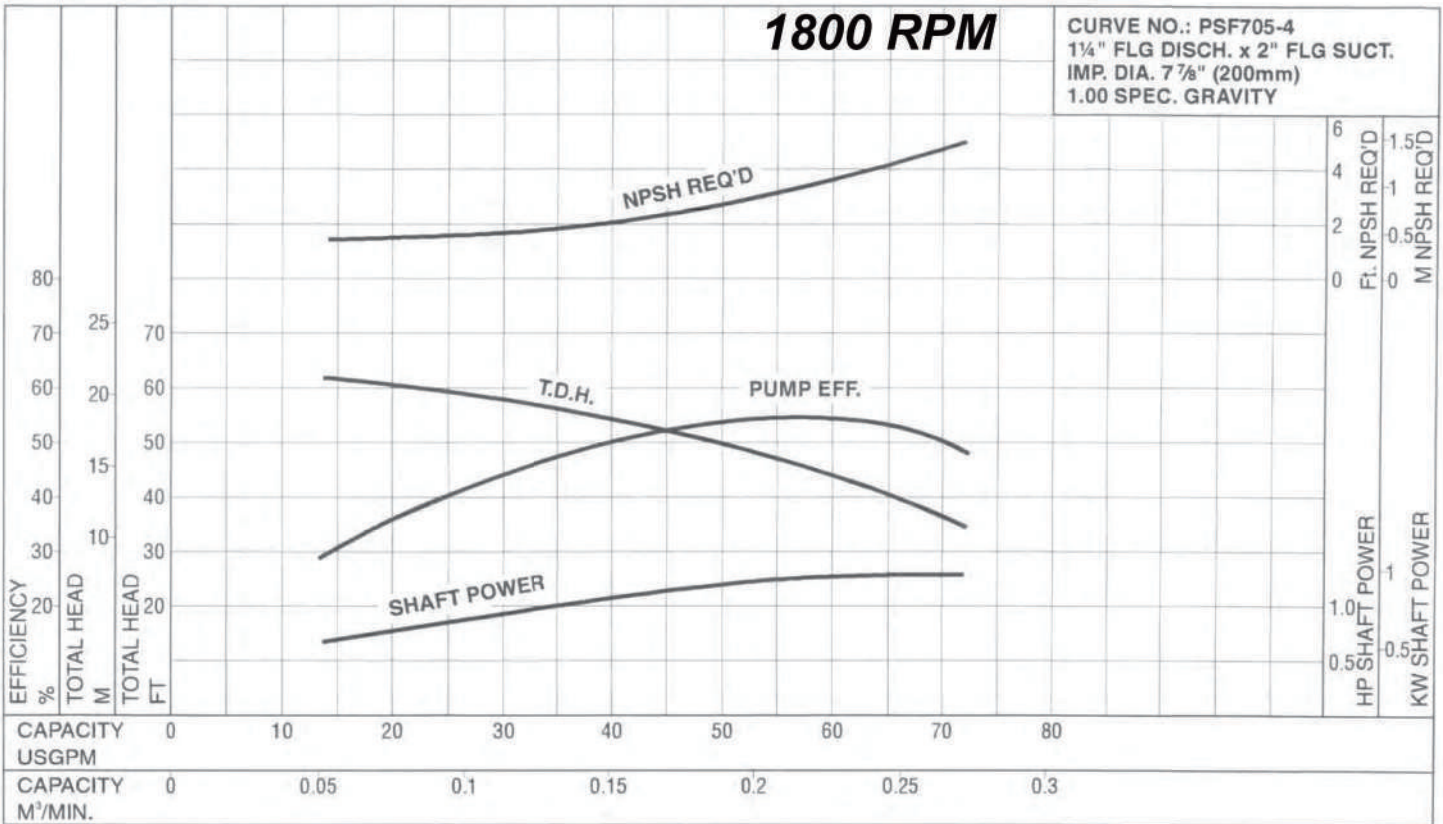



Series PS **MODEL PSF1203**

CUSTOMER _____ REFERENCE _____

FLUID _____ S.G. _____ TEMP _____ CAPACITY _____ TDH _____

CERTIFIED: _____ DATE: _____

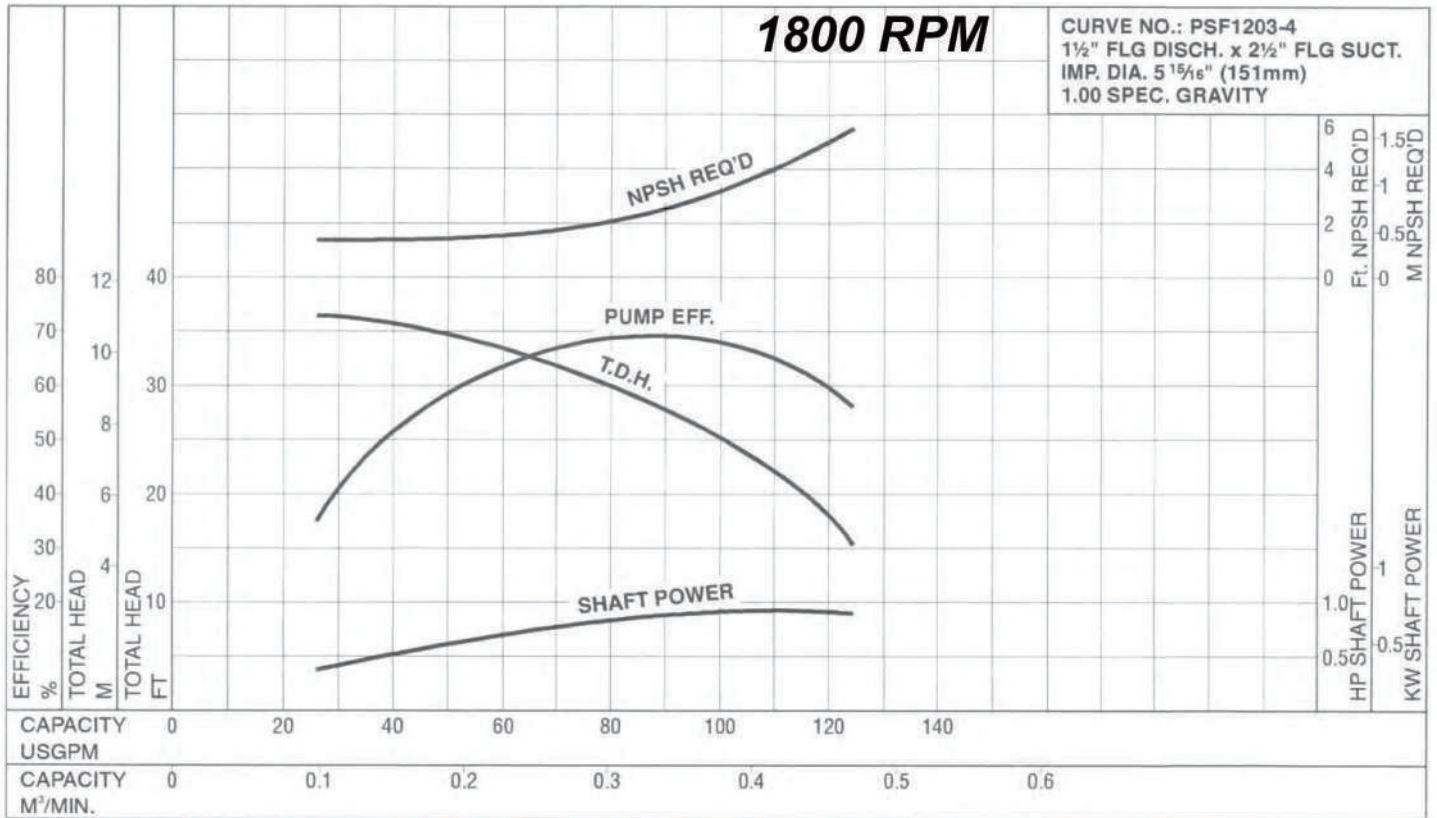



Series PS **MODEL PSF1205**

CUSTOMER _____ REFERENCE _____

FLUID _____ S.G. _____ TEMP _____ CAPACITY _____ TDH _____

CERTIFIED: _____ DATE: _____

1800 RPM

CURVE NO.: PSF1205-4
 1½" FLG DISCH. x 2½" FLG SUCT.
 IMP. DIA. 7 ¾" (183mm)
 1.00 SPEC. GRAVITY

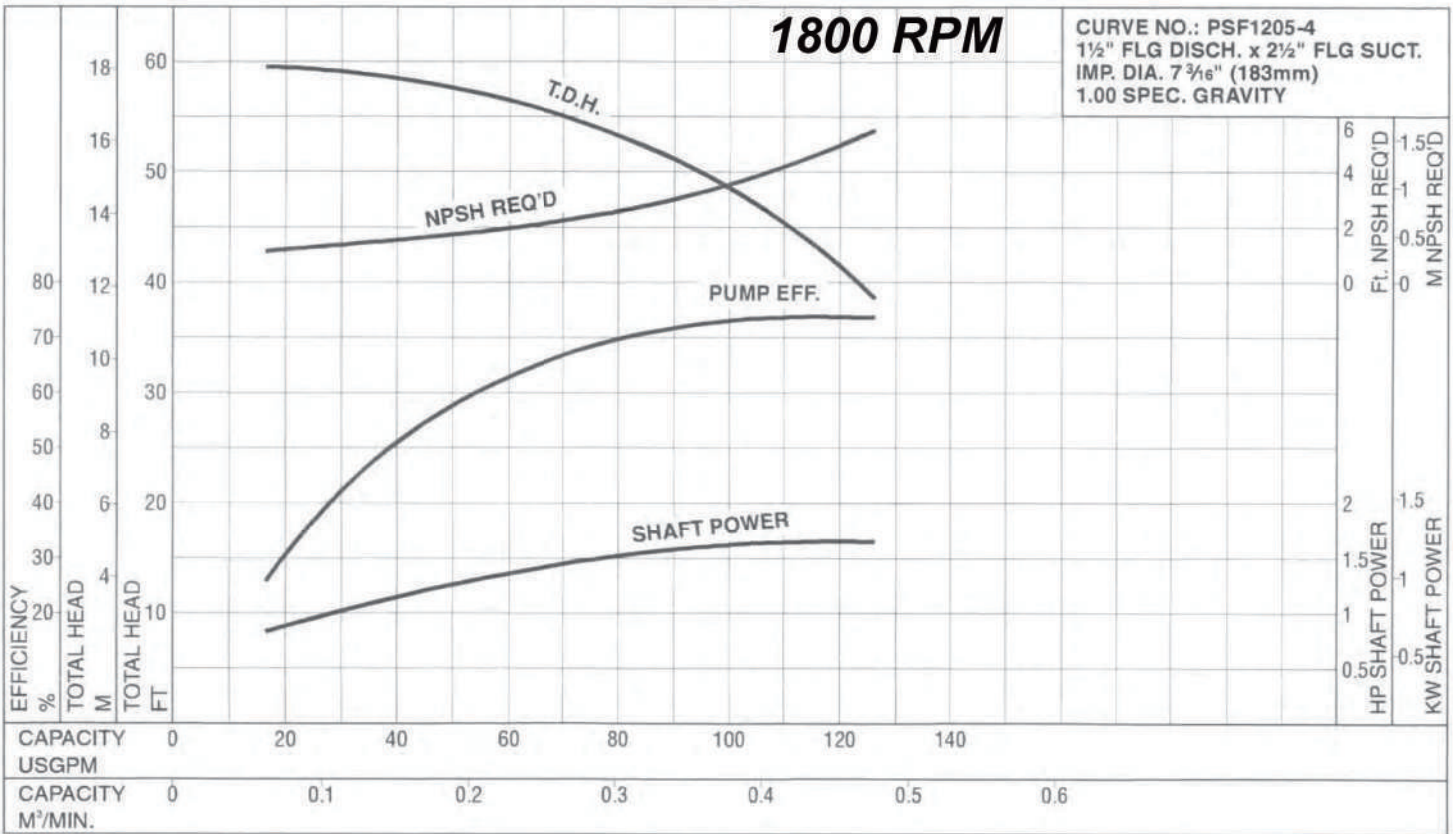



Series PS **MODEL PSF1206**

CUSTOMER _____ REFERENCE _____

FLUID _____ S.G. _____ TEMP _____ CAPACITY _____ TDH _____

CERTIFIED: _____ DATE: _____

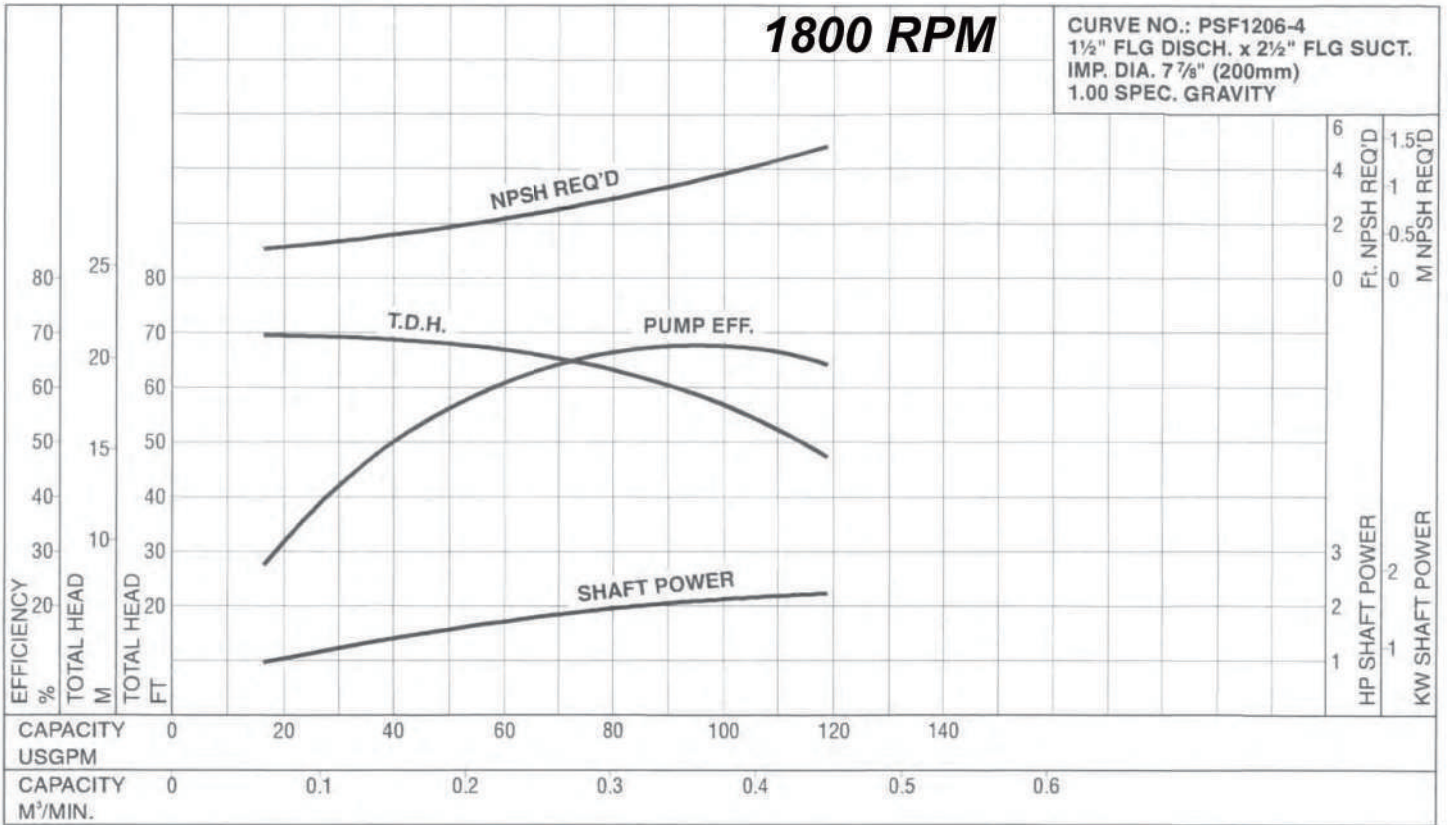



Series PS **MODEL PSF2001**

CUSTOMER _____ REFERENCE _____

FLUID _____ S.G. _____ TEMP _____ CAPACITY _____ TDH _____

CERTIFIED: _____ DATE: _____

1800 RPM

CURVE NO.: PSF2001-4
 2" FLG DISCH. x 2½" FLG SUCT.
 IMP. DIA. 5 3/16" (131mm)
 1.00 SPEC. GRAVITY

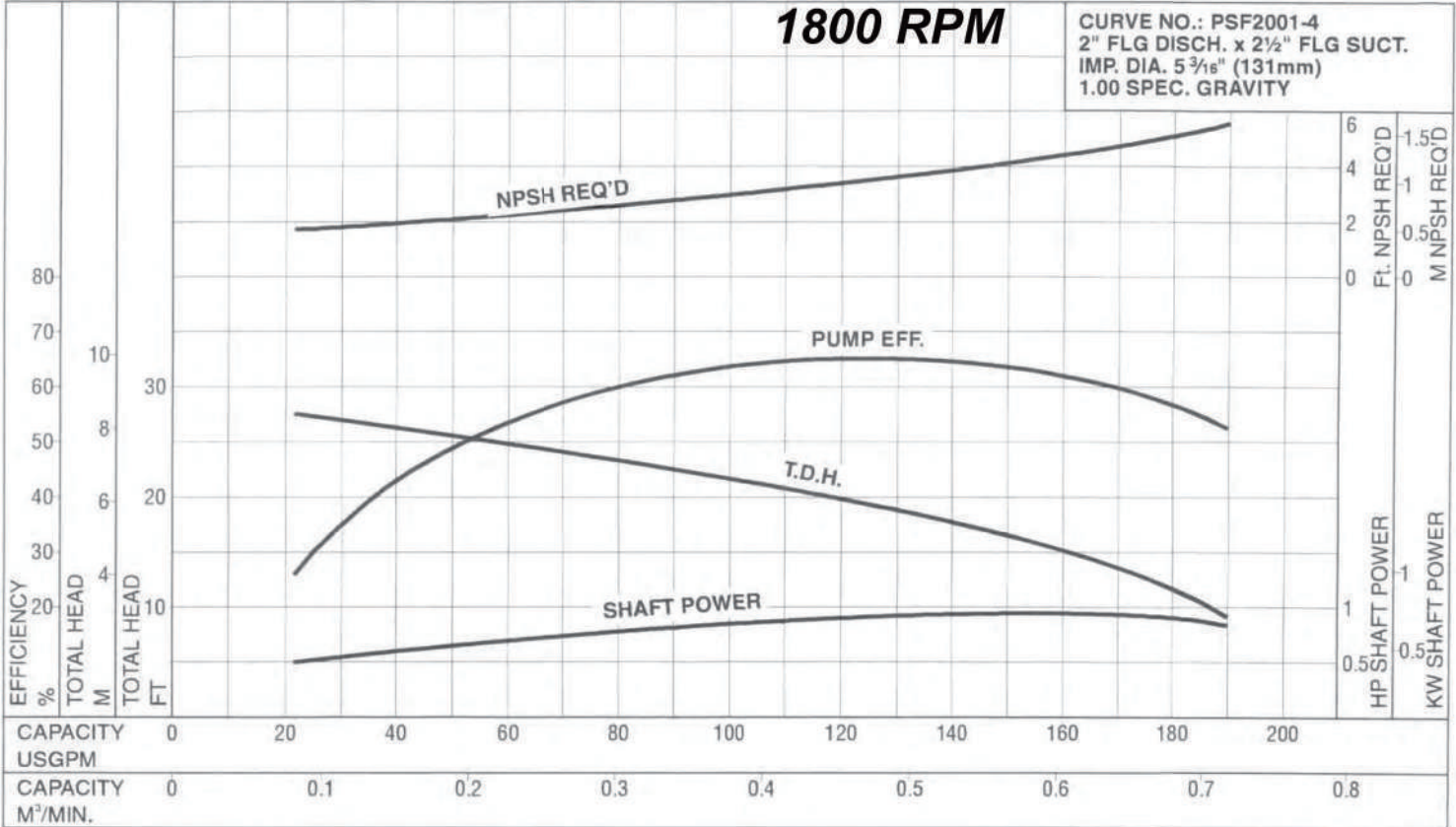



Series PS **MODEL PSF2003**

CUSTOMER _____ REFERENCE _____

FLUID _____ S.G. _____ TEMP _____ CAPACITY _____ TDH _____

CERTIFIED: _____ DATE: _____

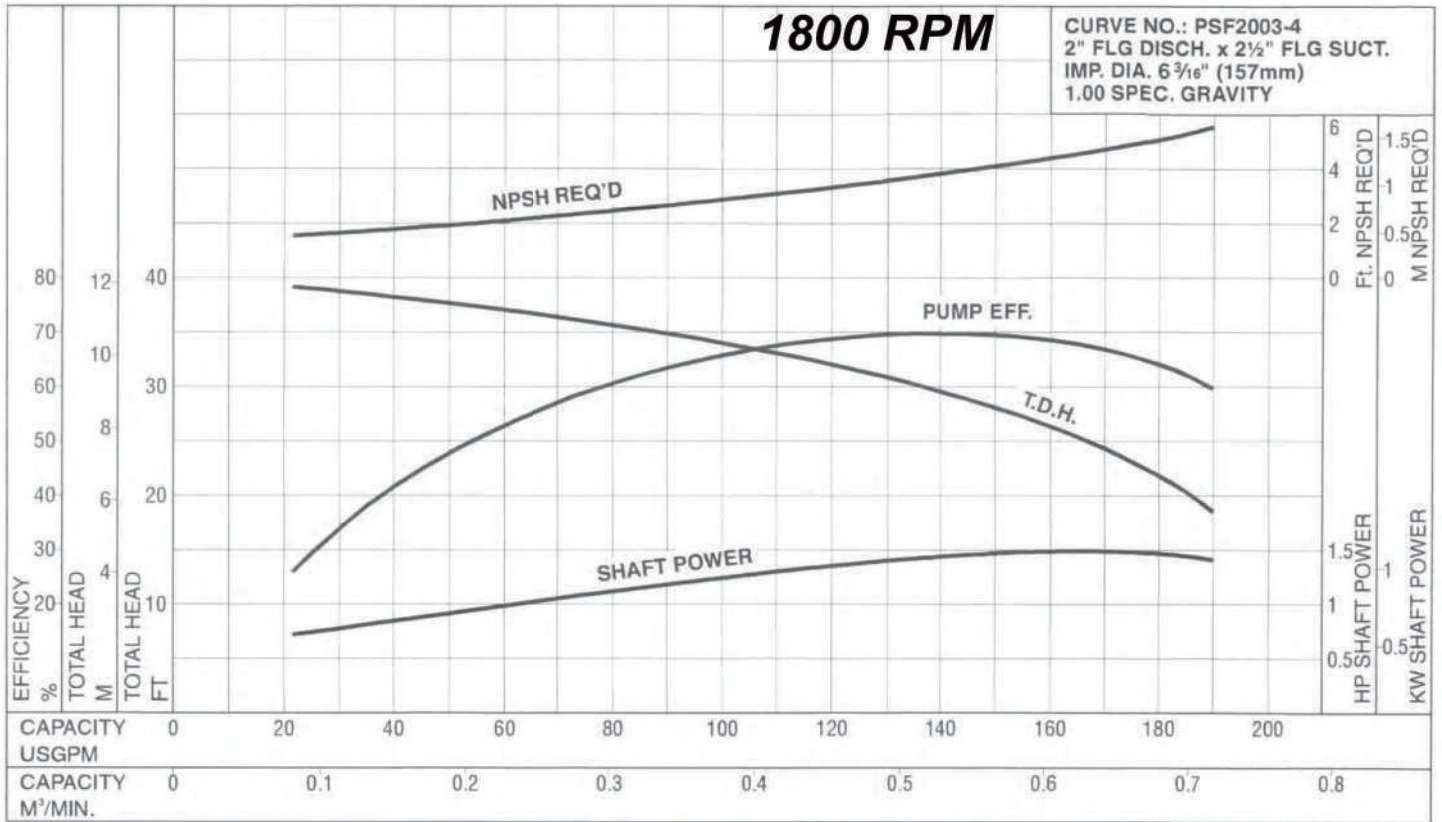



Series PS **MODEL PSF2004**

CUSTOMER _____ REFERENCE _____

FLUID _____ S.G. _____ TEMP _____ CAPACITY _____ TDH _____

CERTIFIED: _____ DATE: _____

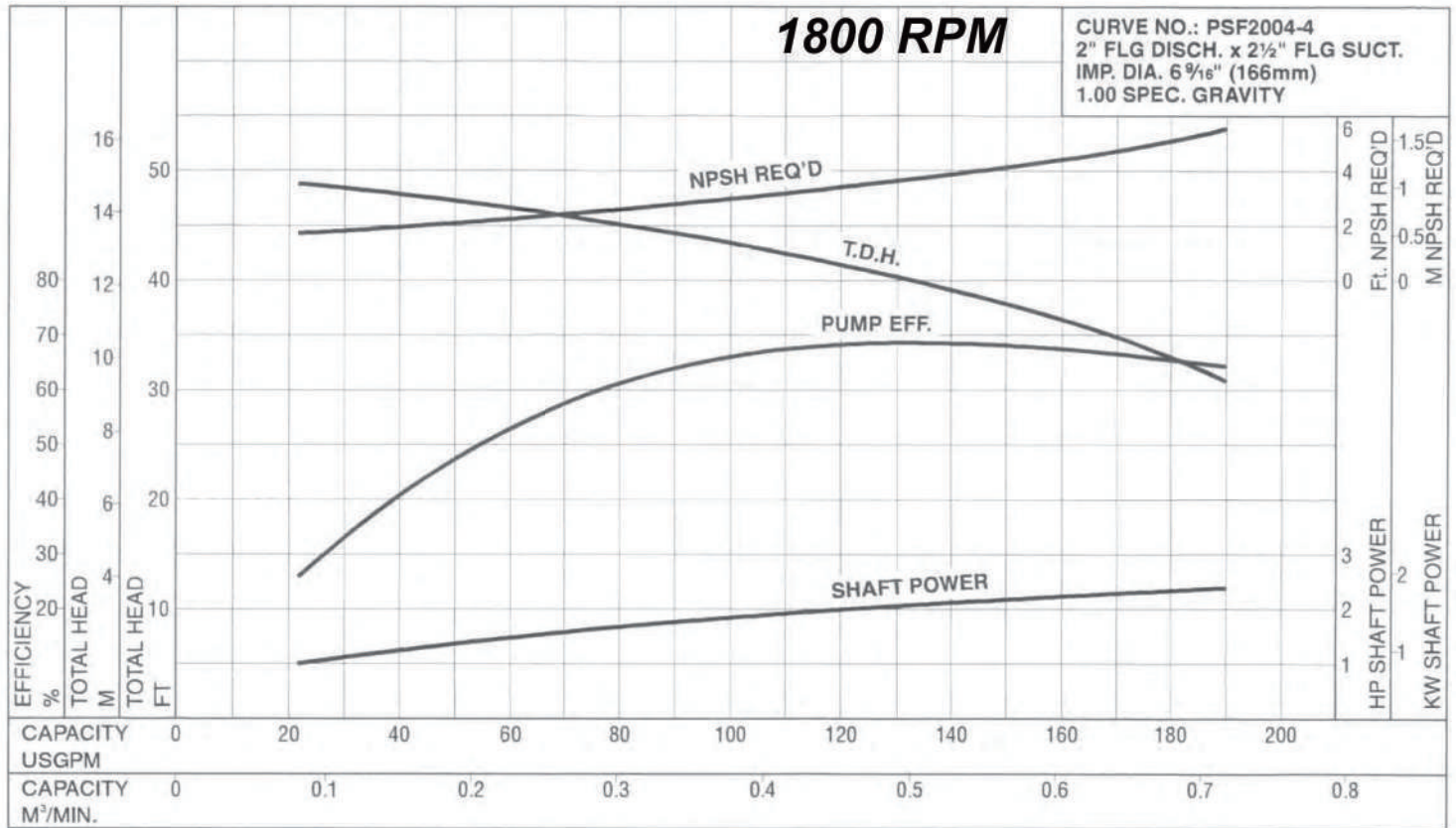



SERIES PS Specifications MODEL - PSF

Model PSF Selection Chart (3450 RPM)

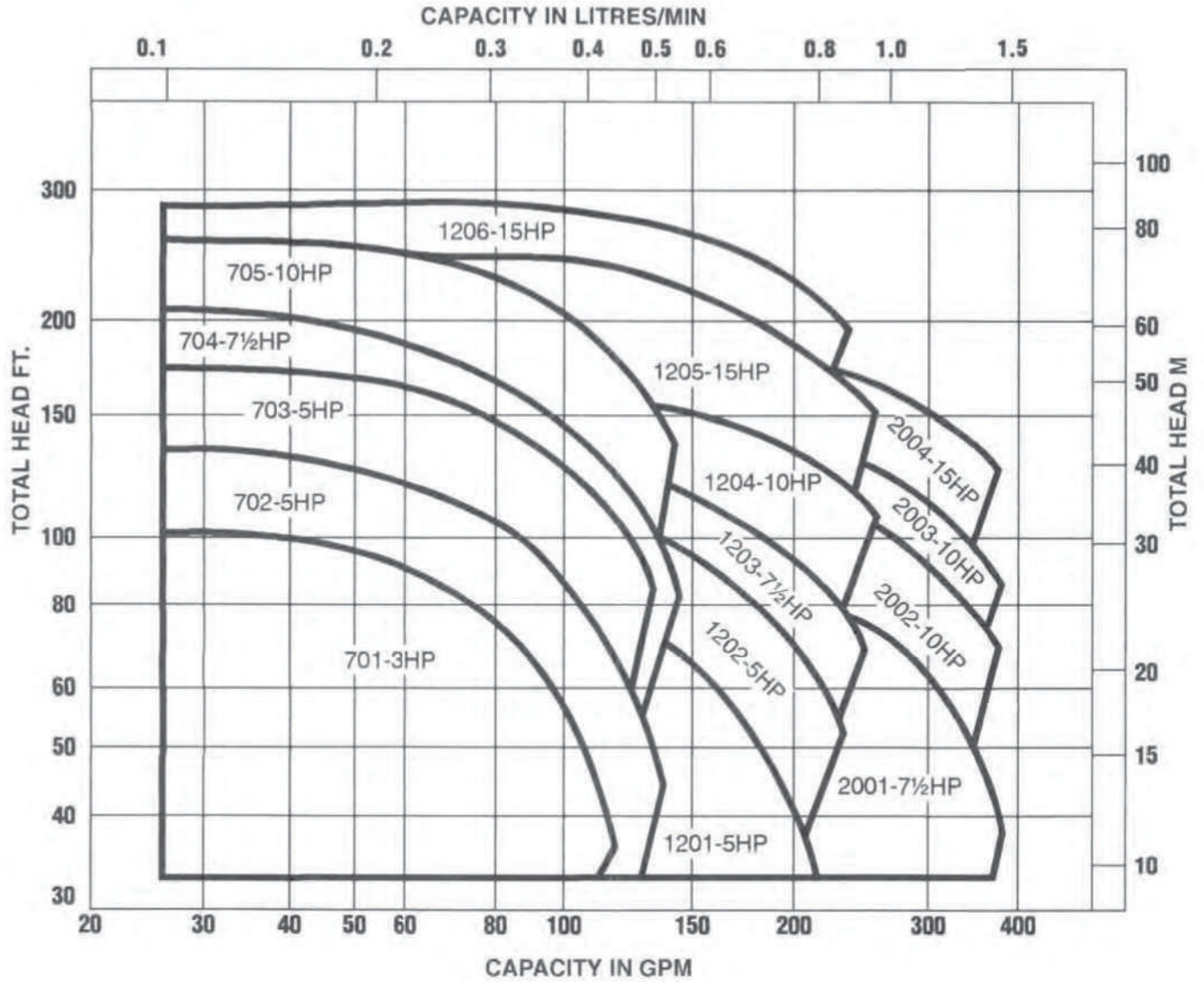



Series PS **MODEL PSF701**

CUSTOMER _____ REFERENCE _____

FLUID _____ S.G. _____ TEMP _____ CAPACITY _____ TDH _____

CERTIFIED: _____ DATE: _____

3600 RPM

CURVE NO.: **PSF701-2**
 1 1/4" FLG DISCH. x 2" FLG SUCT.
 IMP. DIA. 5 3/16" (131mm)
 1.00 SPEC. GRAVITY

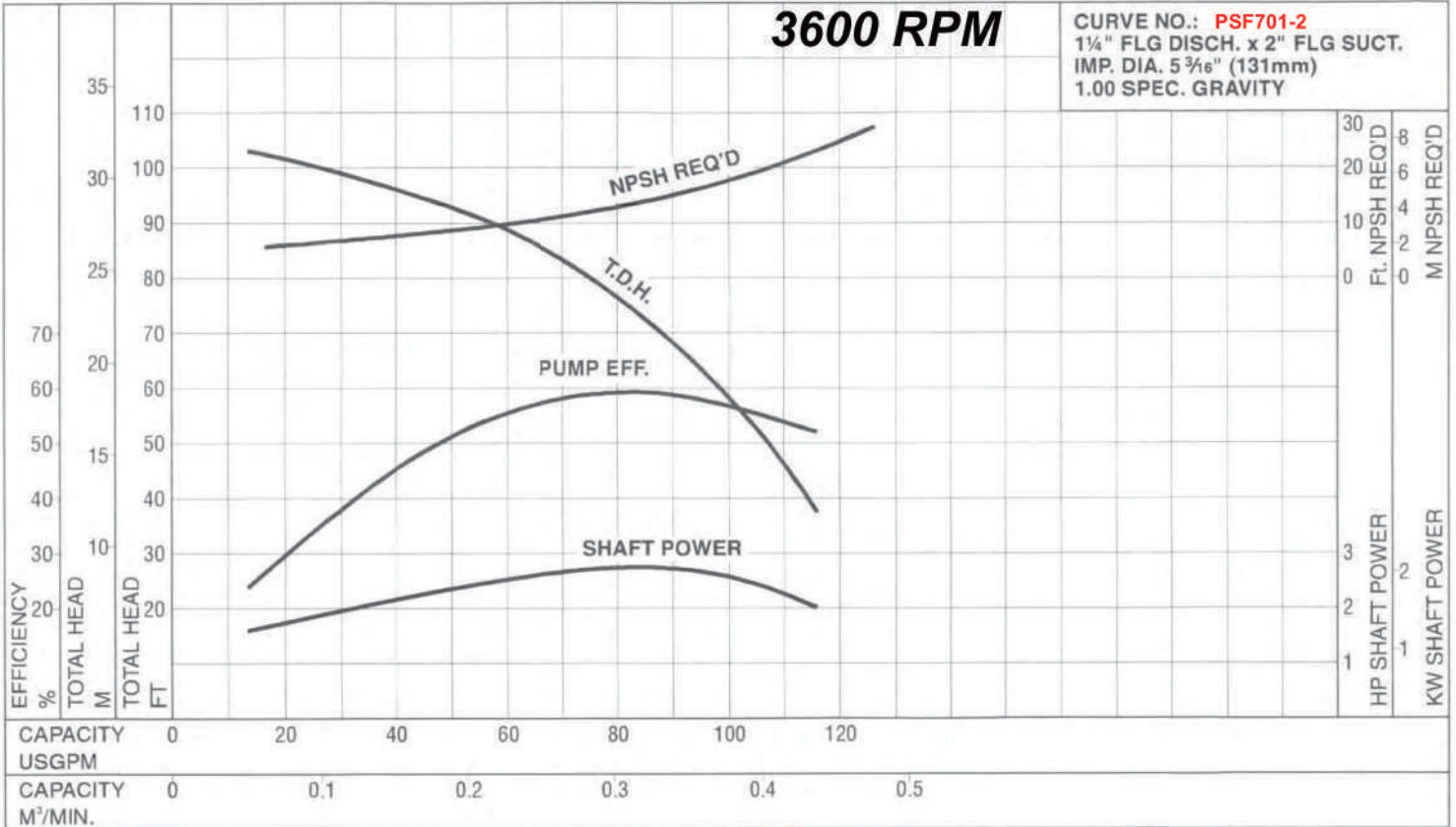



Series PS **MODEL PSF702**

CUSTOMER _____ REFERENCE _____

FLUID _____ S.G. _____ TEMP _____ CAPACITY _____ TDH _____

CERTIFIED: _____ DATE: _____

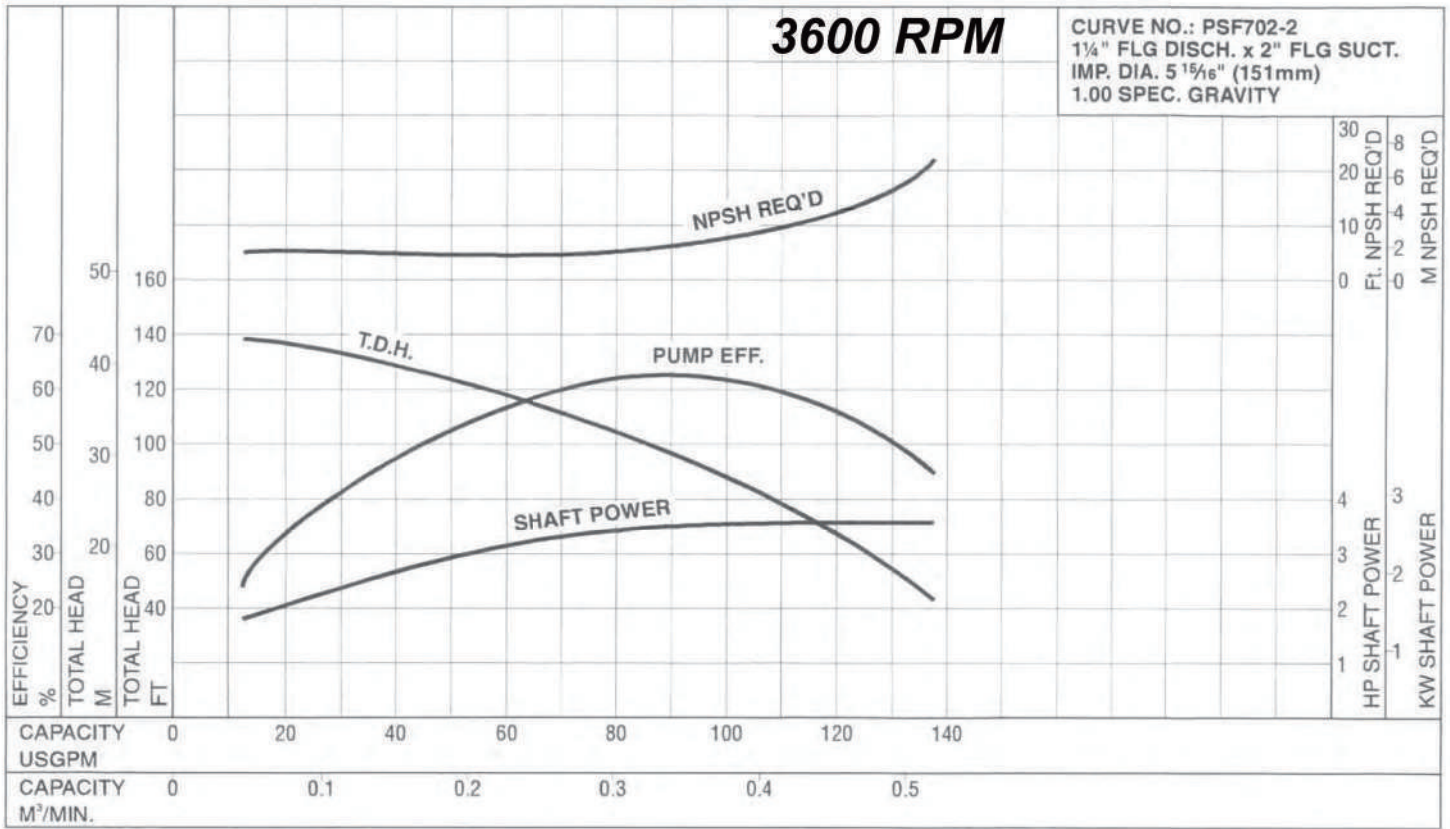



Series PS **MODEL PSF703**

CUSTOMER _____ REFERENCE _____

FLUID _____ S.G. _____ TEMP _____ CAPACITY _____ TDH _____

CERTIFIED: _____ DATE: _____

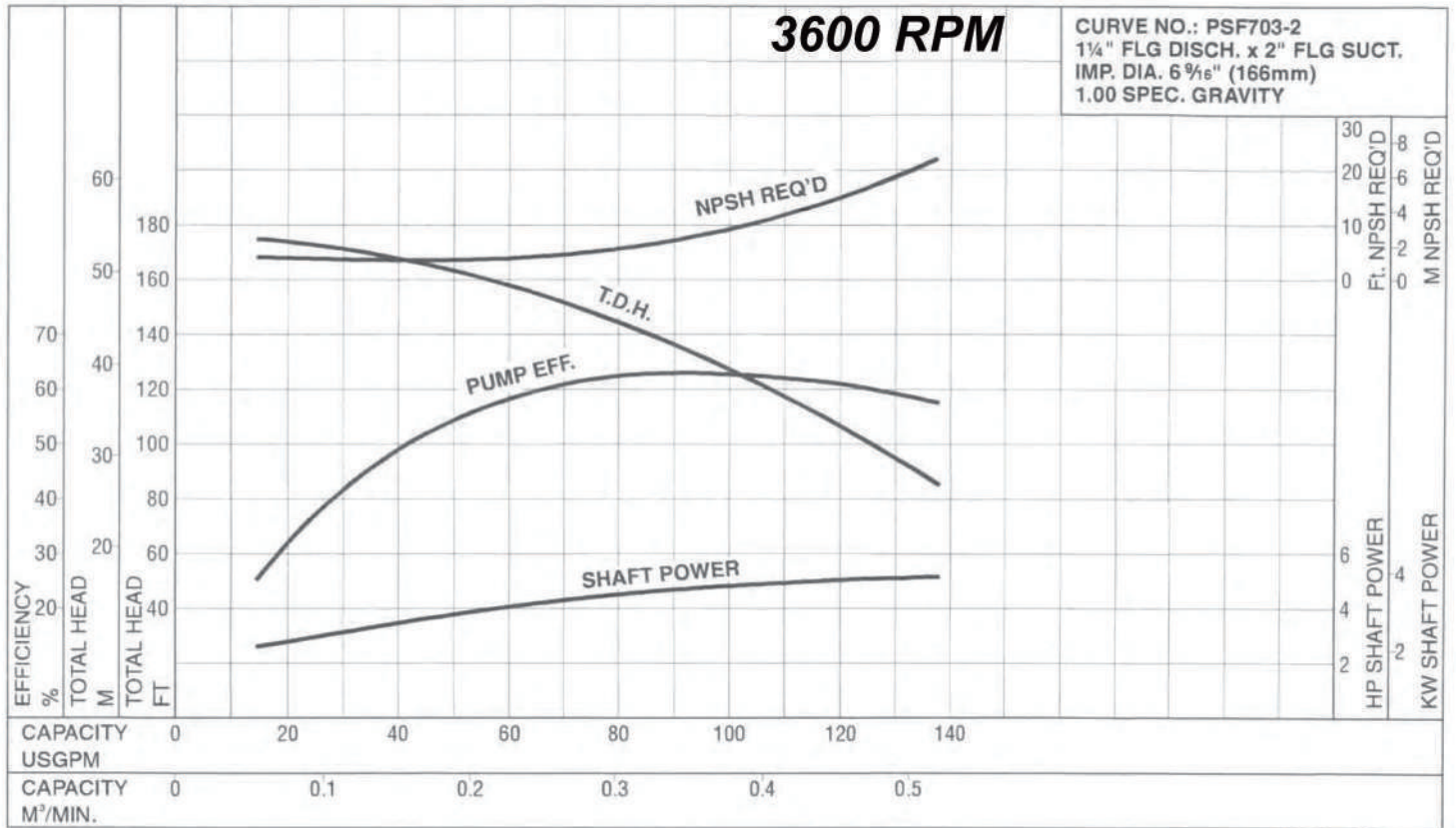



Series PS **MODEL PSF704**

CUSTOMER _____ REFERENCE _____

FLUID _____ S.G. _____ TEMP _____ CAPACITY _____ TDH _____

CERTIFIED: _____ DATE: _____

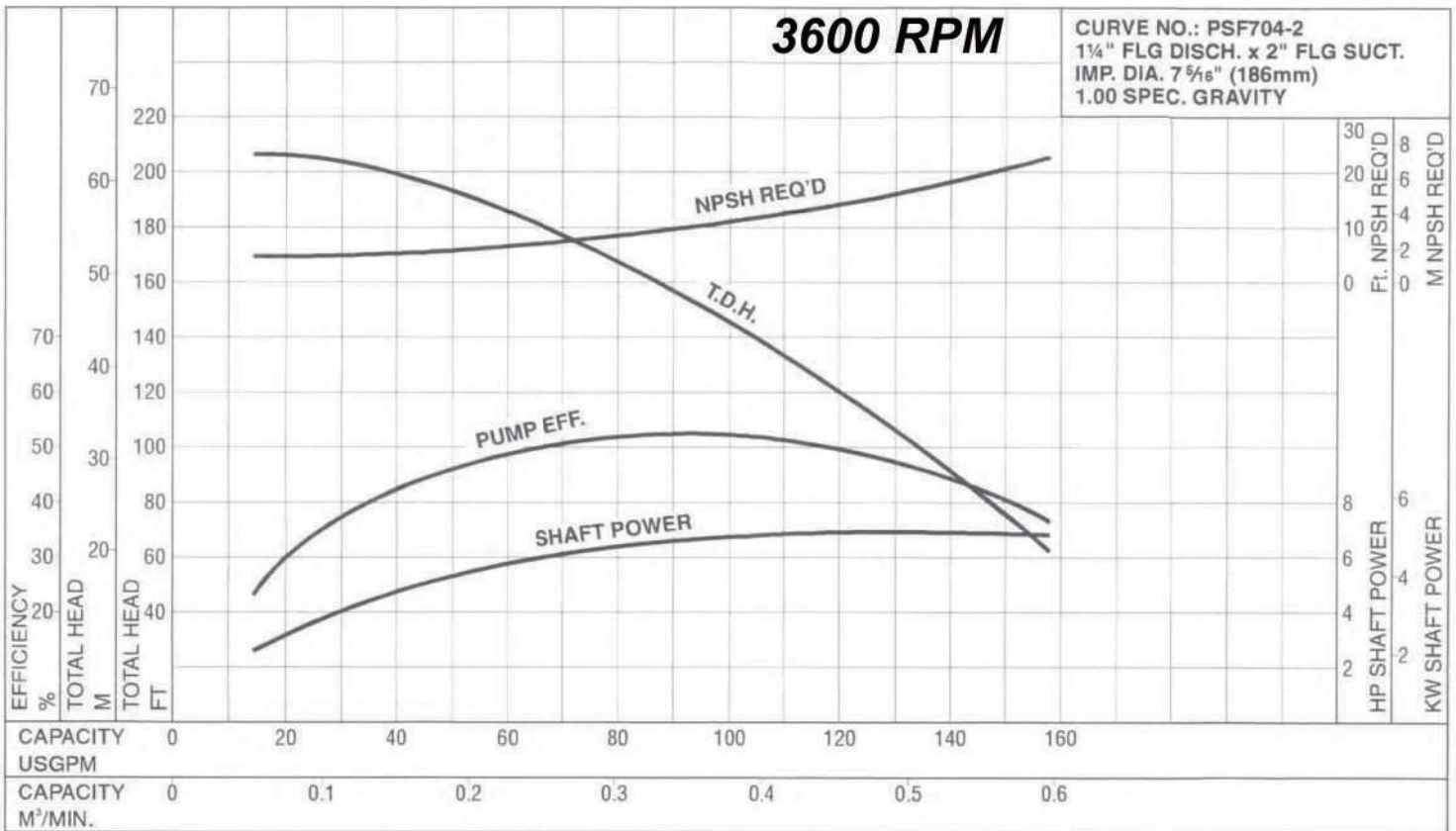



Series PS **MODEL PSF705**

CUSTOMER _____ REFERENCE _____

FLUID _____ S.G. _____ TEMP _____ CAPACITY _____ TDH _____

CERTIFIED: _____ DATE: _____

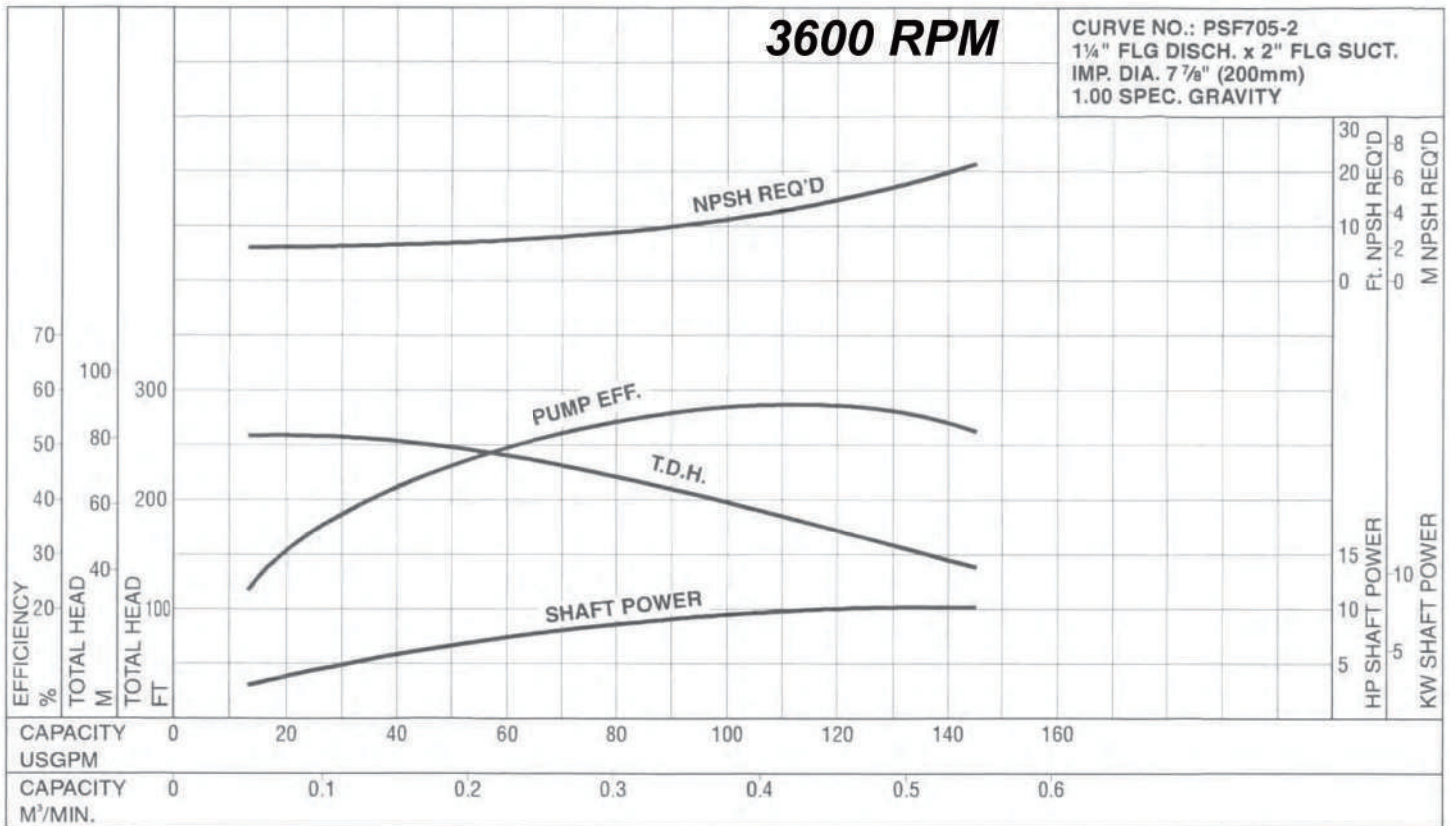



Series PS **MODEL PSF1201**

CUSTOMER _____ REFERENCE _____

FLUID _____ S.G. _____ TEMP _____ CAPACITY _____ TDH _____

CERTIFIED: _____ DATE: _____

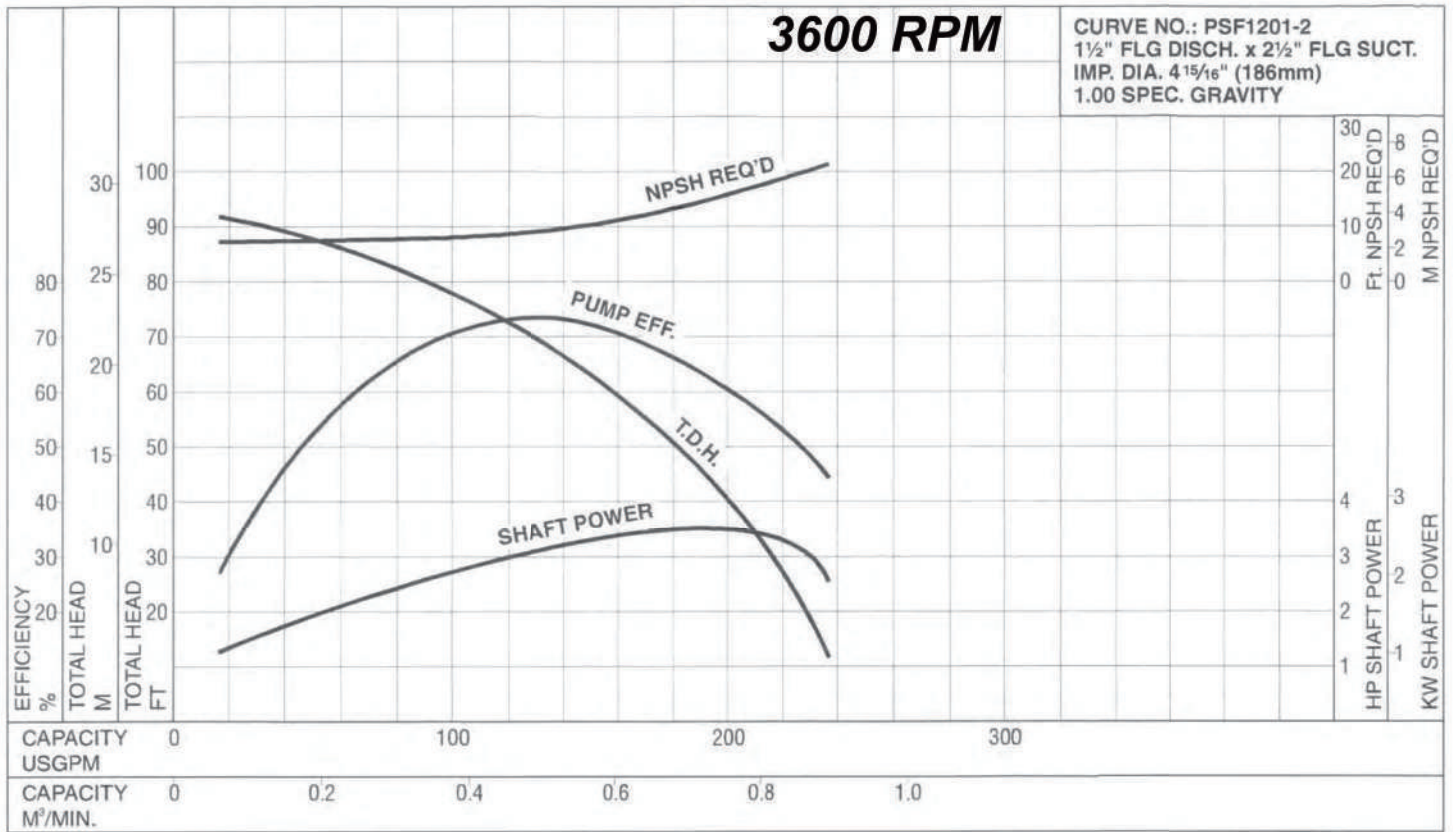



Series PS **MODEL PSF1202**

CUSTOMER _____ REFERENCE _____

FLUID _____ S.G. _____ TEMP _____ CAPACITY _____ TDH _____

CERTIFIED: _____ DATE: _____

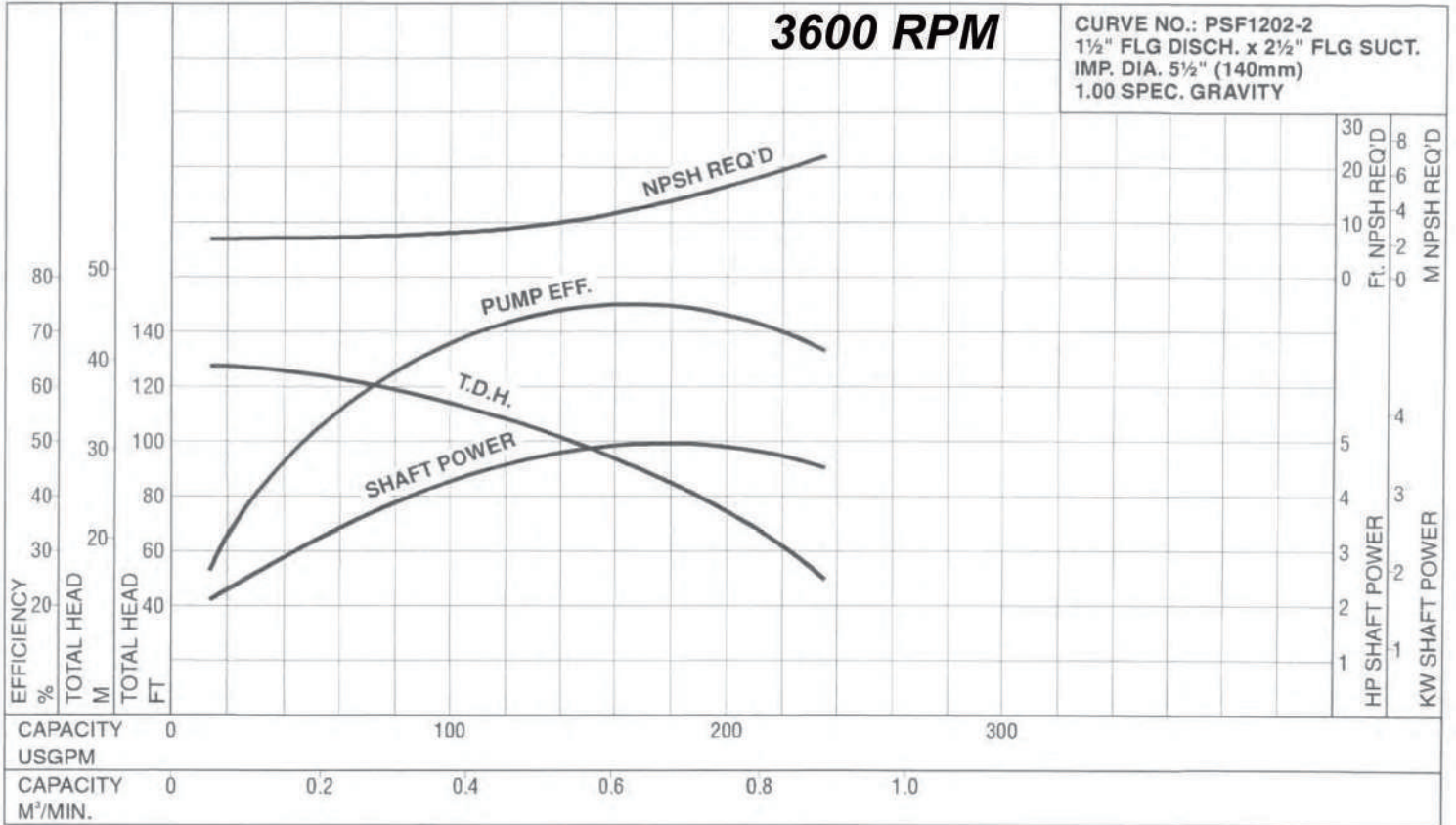



Series PS **MODEL PSF1203**

CUSTOMER _____ REFERENCE _____

FLUID _____ S.G. _____ TEMP _____ CAPACITY _____ TDH _____

CERTIFIED: _____ DATE: _____

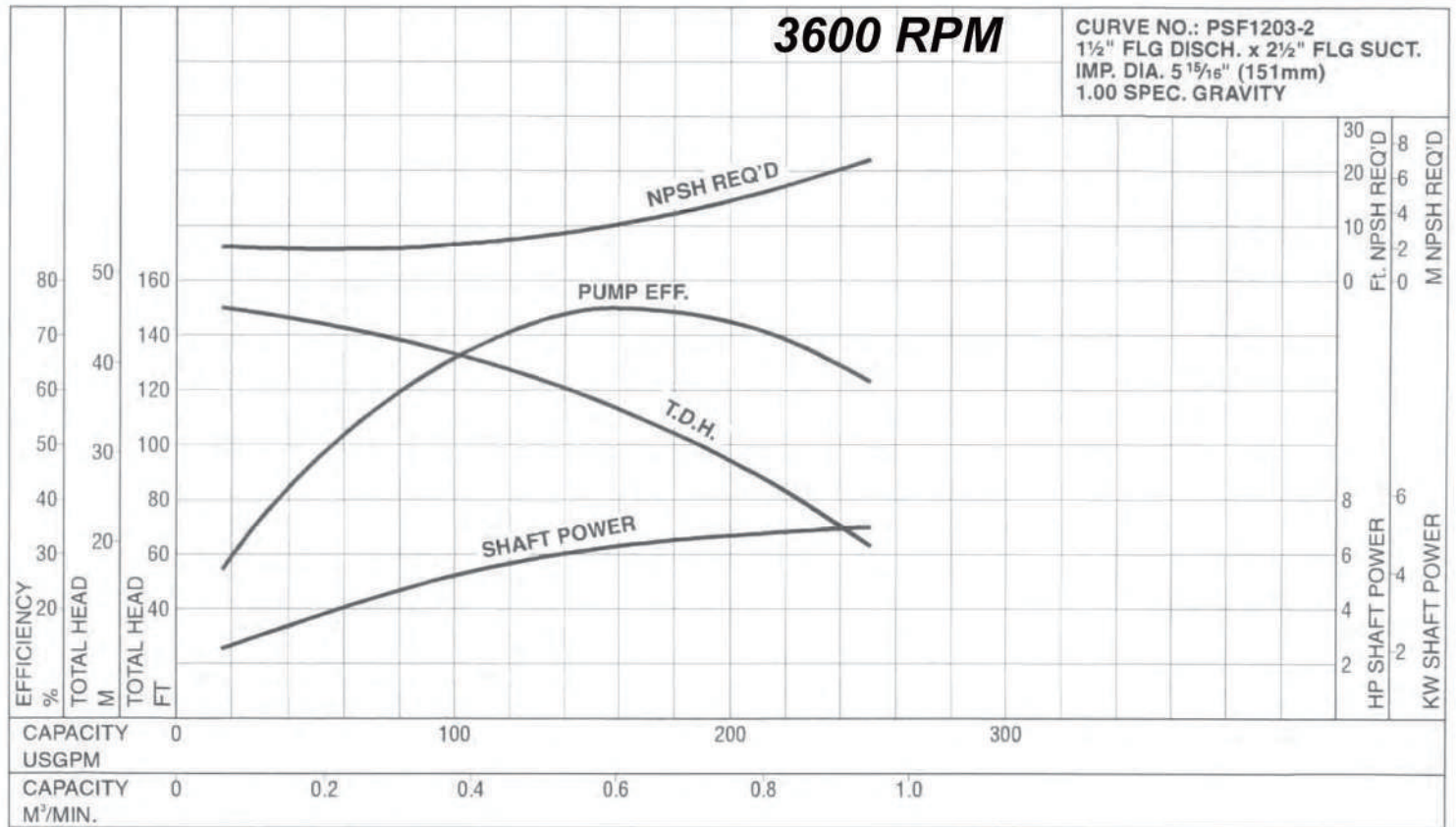



Series PS **MODEL PSF1204**

CUSTOMER _____ REFERENCE _____

FLUID _____ S.G. _____ TEMP _____ CAPACITY _____ TDH _____

CERTIFIED: _____ DATE: _____

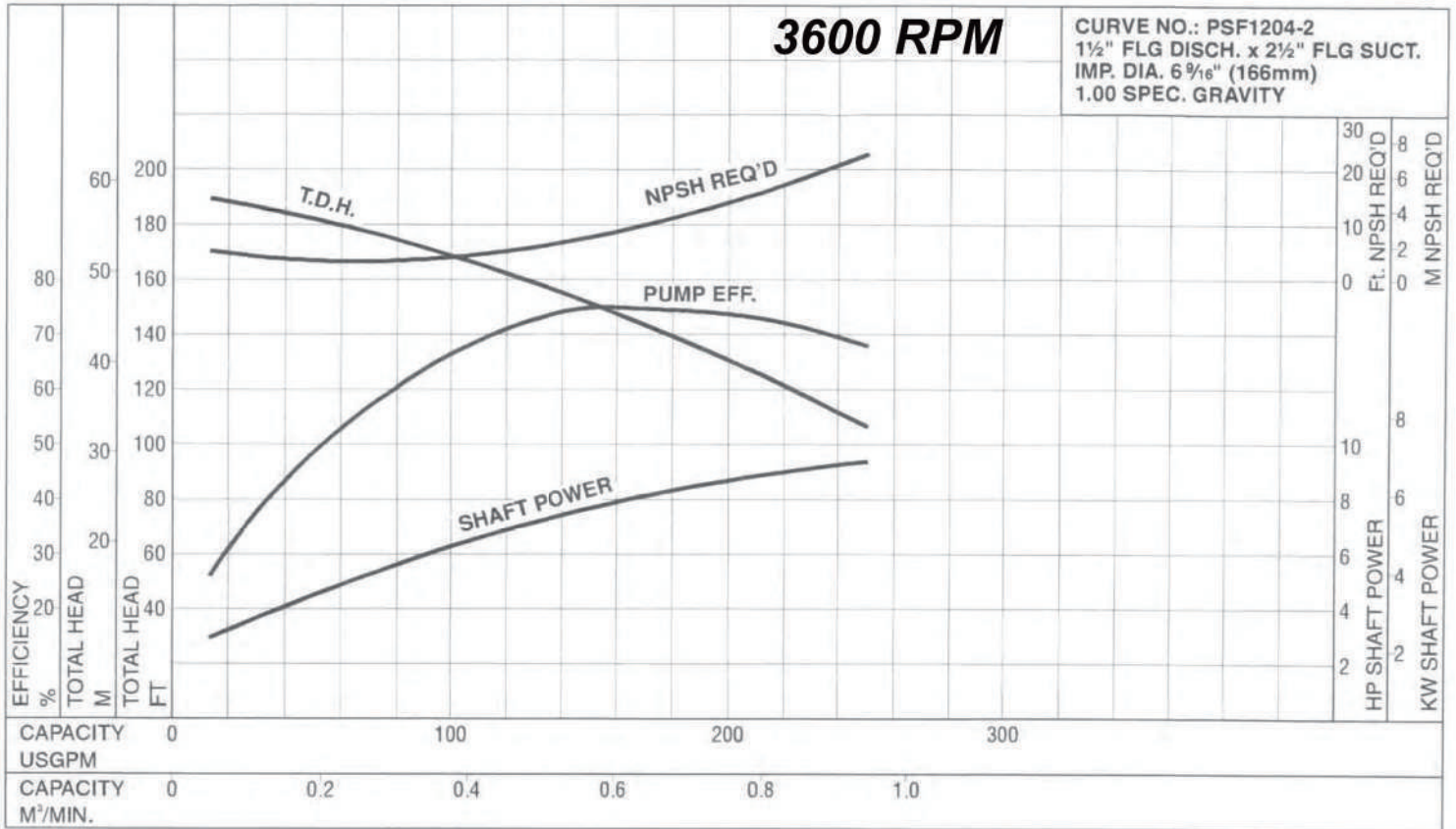



Series PS **MODEL PSF1205**

CUSTOMER _____ REFERENCE _____

FLUID _____ S.G. _____ TEMP _____ CAPACITY _____ TDH _____

CERTIFIED: _____ DATE: _____

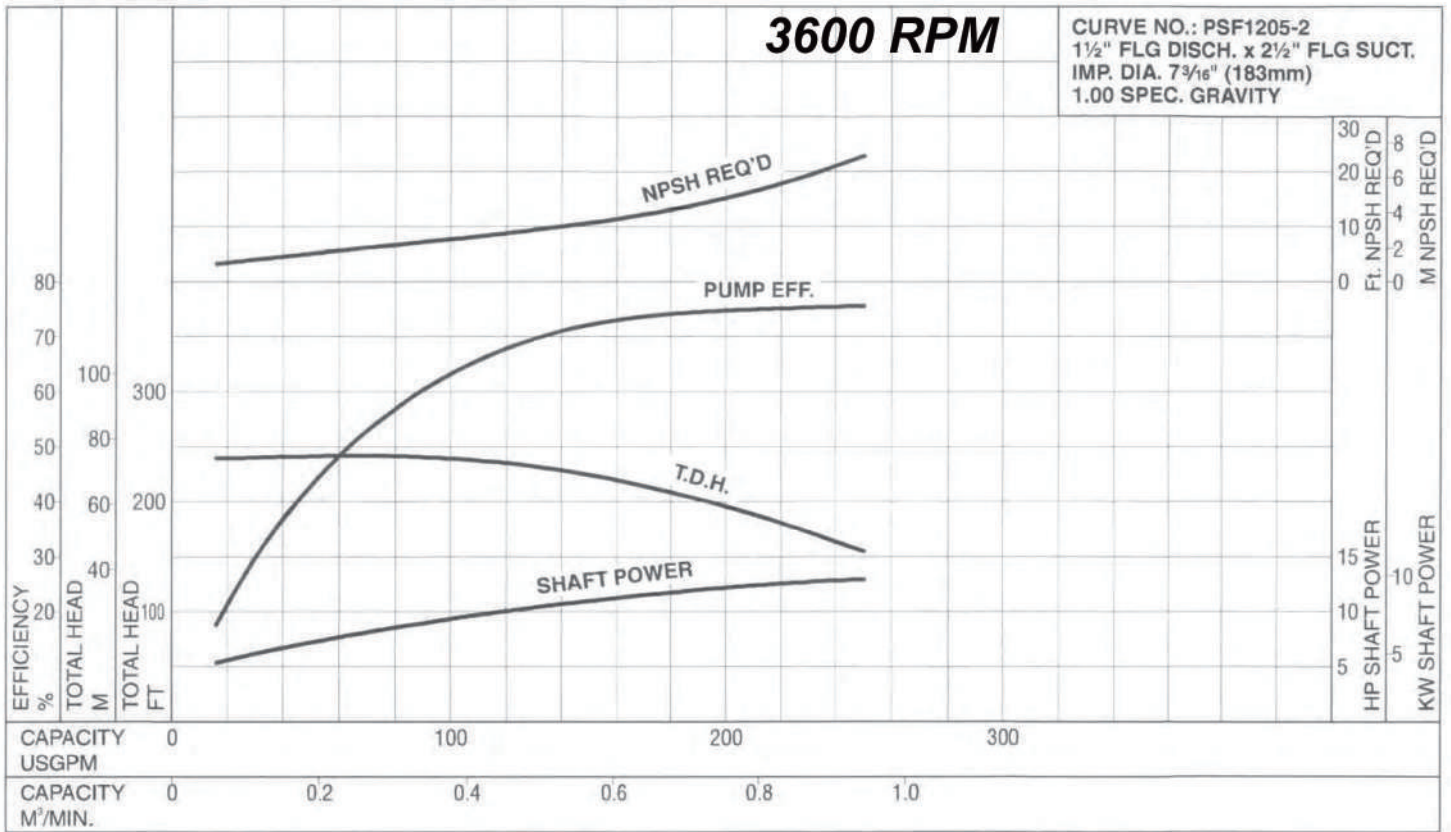



Series PS **MODEL PSF1206**

CUSTOMER _____ REFERENCE _____

FLUID _____ S.G. _____ TEMP _____ CAPACITY _____ TDH _____

CERTIFIED: _____ DATE: _____

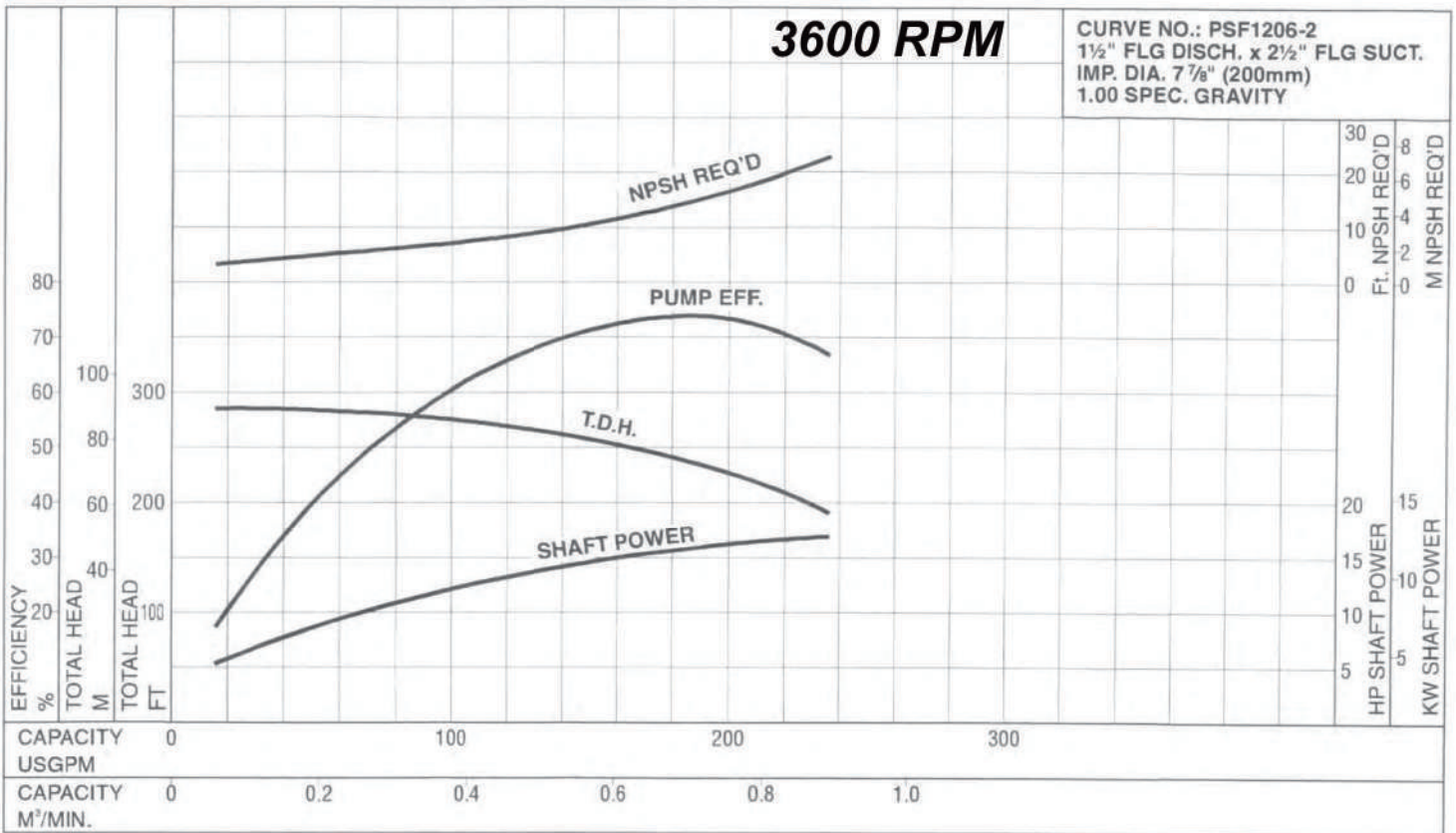



Series PS **MODEL PSF2001**

CUSTOMER _____ REFERENCE _____

FLUID _____ S.G. _____ TEMP _____ CAPACITY _____ TDH _____

CERTIFIED: _____ DATE: _____

3600 RPM

CURVE NO.: PSF2001-2
 2" FLG DISCH. x 2½" FLG SUCT.
 IMP. DIA. 5¾" (131mm)
 1.00 SPEC. GRAVITY

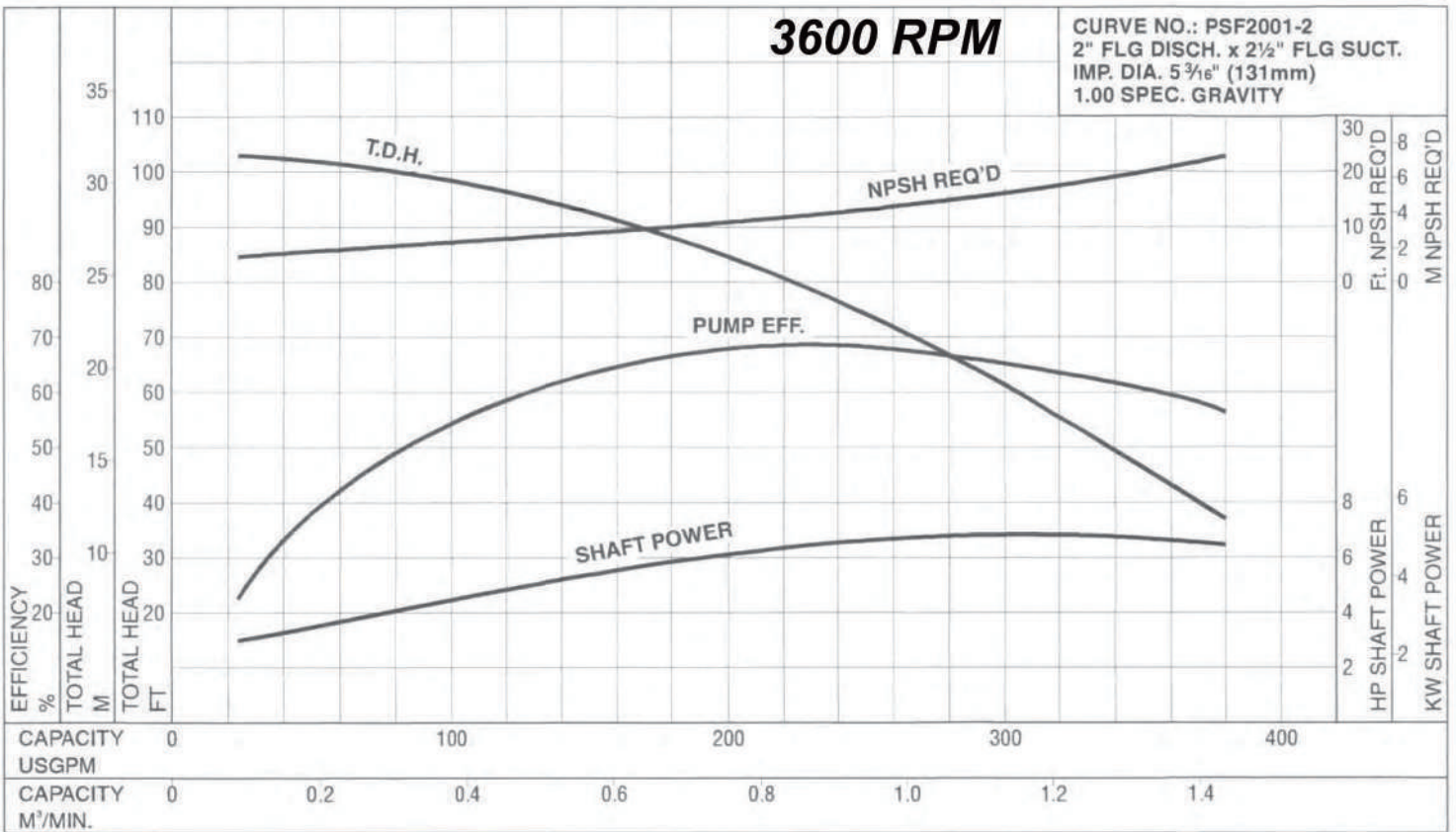



Series PS **MODEL PSF2002**

CUSTOMER _____ REFERENCE _____

FLUID _____ S.G. _____ TEMP _____ CAPACITY _____ TDH _____

CERTIFIED: _____ DATE: _____

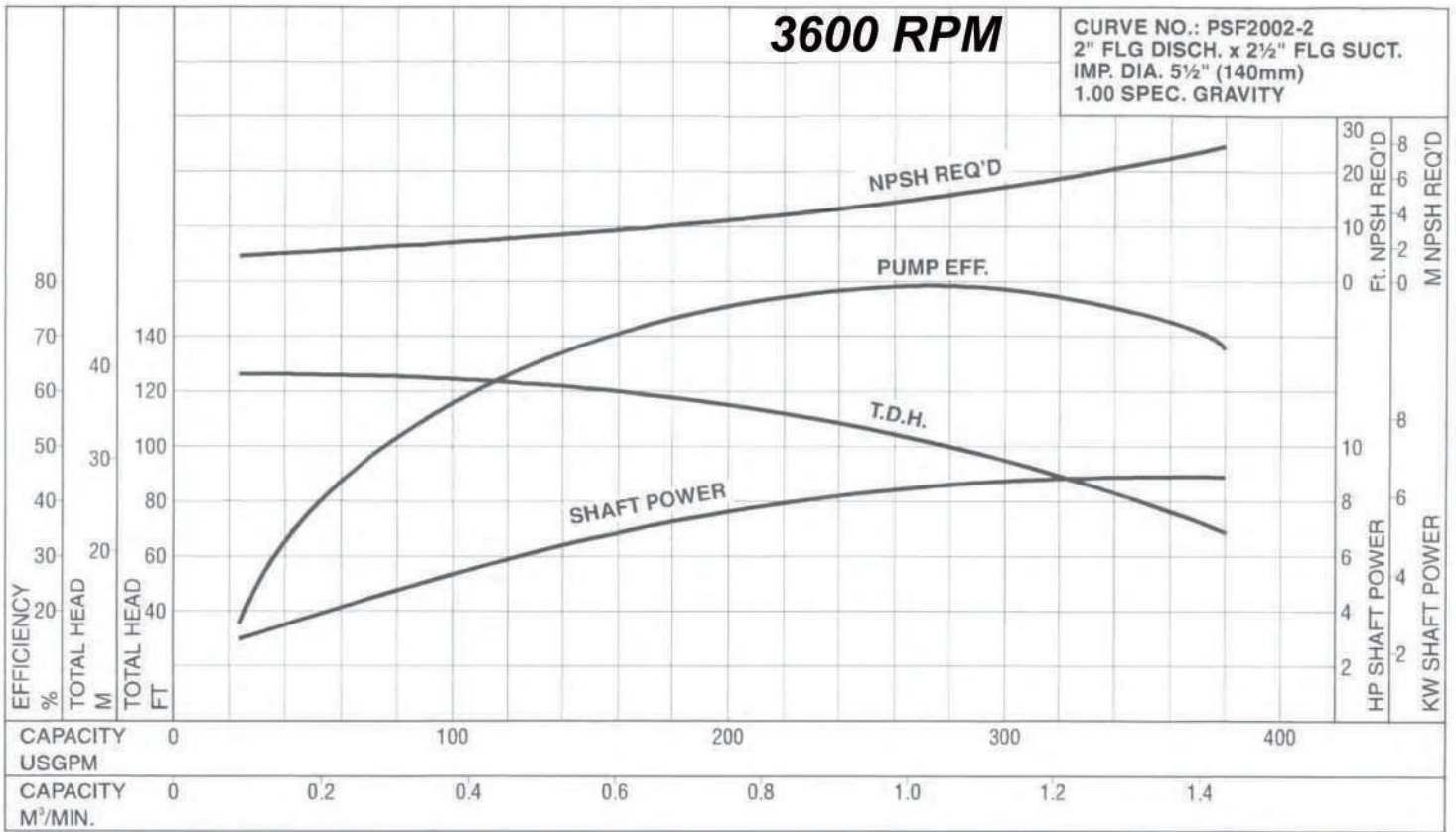



Series PS **MODEL PSF2003**

CUSTOMER _____ REFERENCE _____

FLUID _____ S.G. _____ TEMP _____ CAPACITY _____ TDH _____

CERTIFIED: _____ DATE: _____

3600 RPM

CURVE NO.: PSF2003-2
 2" FLG DISCH. x 2½" FLG SUCT.
 IMP. DIA. 6 ¾" (157mm)
 1.00 SPEC. GRAVITY

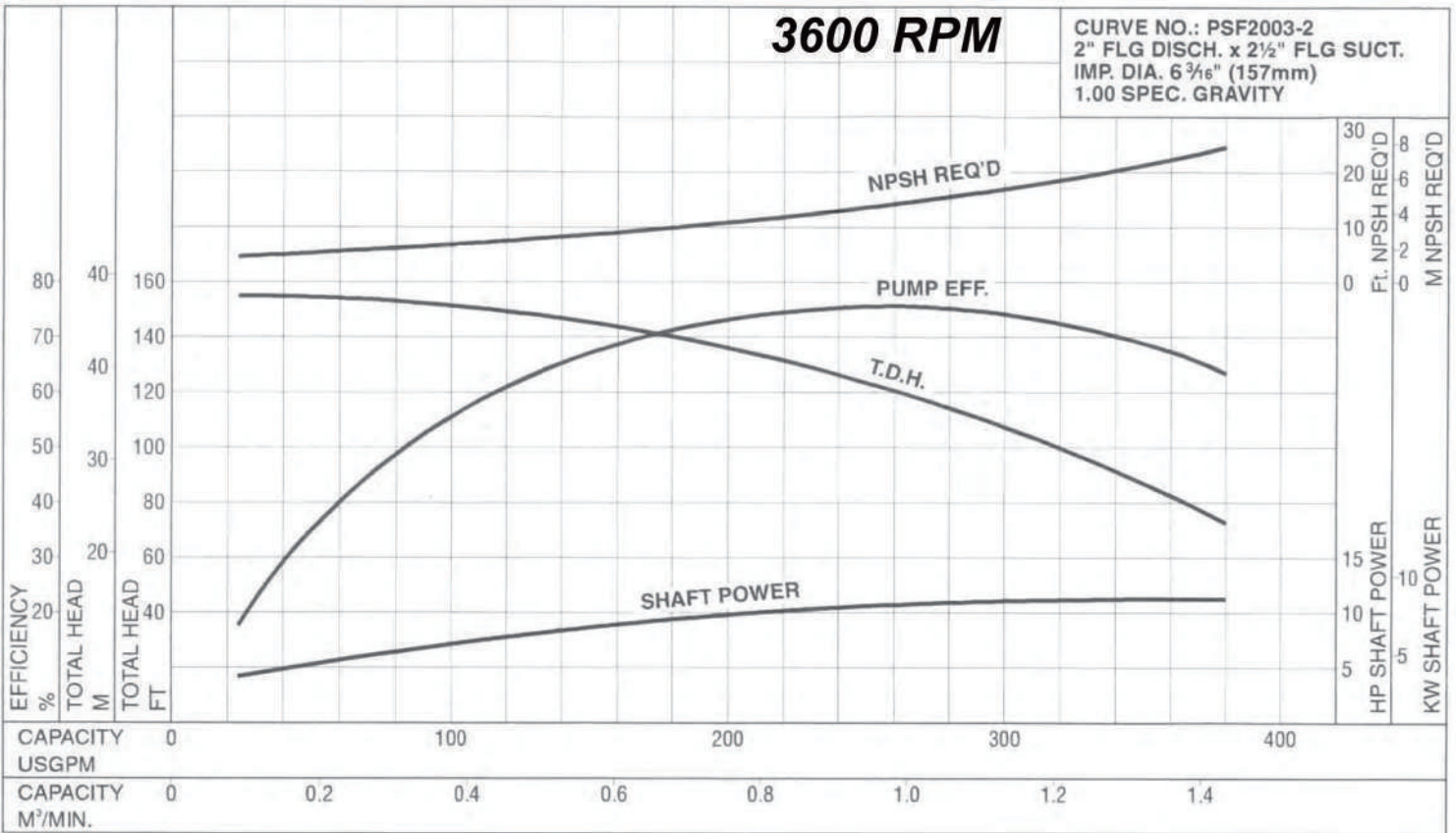



Series PS **MODEL PSF2004**

CUSTOMER _____ REFERENCE _____

FLUID _____ S.G. _____ TEMP _____ CAPACITY _____ TDH _____

CERTIFIED: _____ DATE: _____

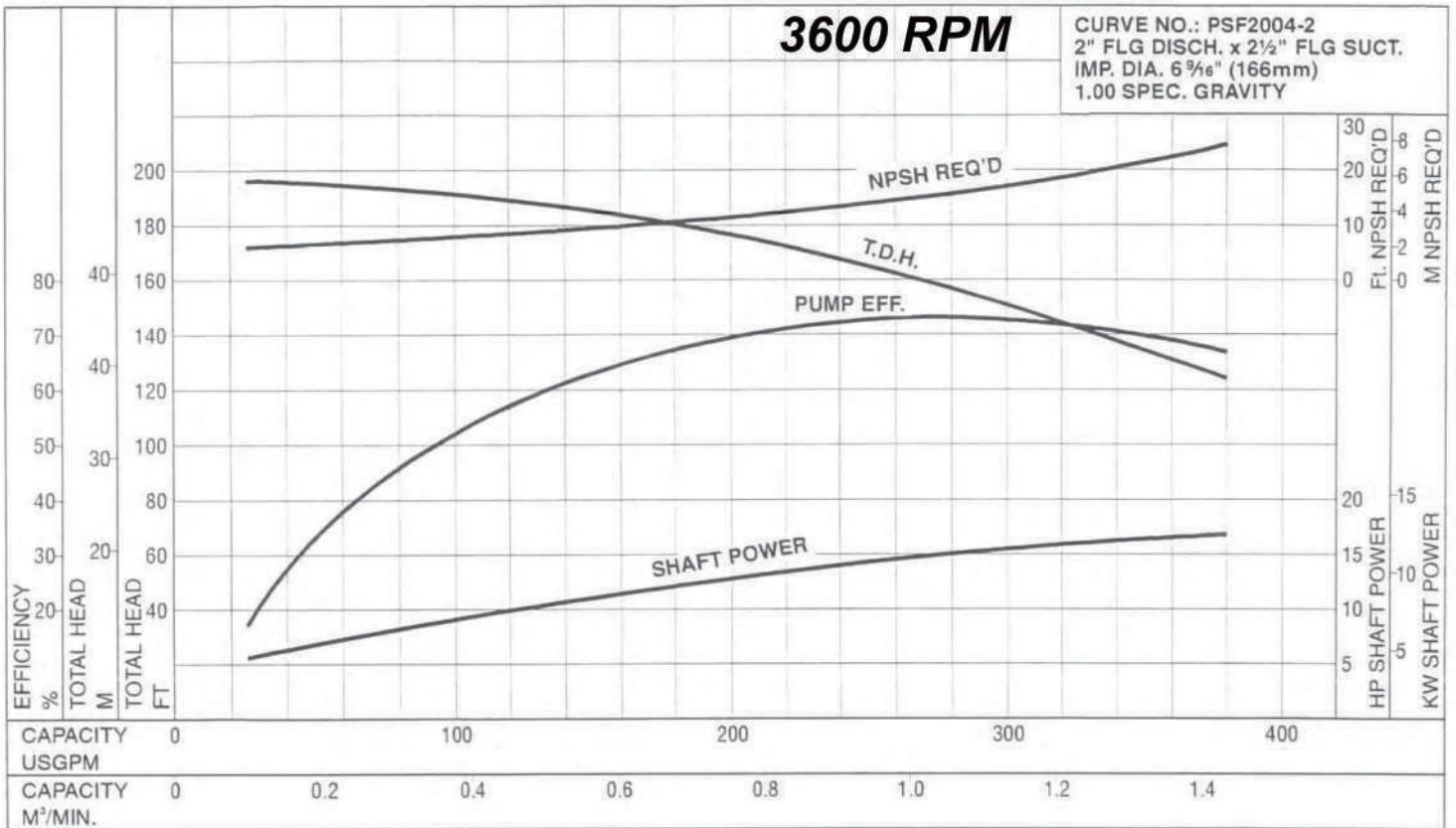



SERIES PS
Performance Curve
MODEL - PSF3001

Synchronous Speed - 3450 RPM

2-1/2" Discharge x 3" Suction

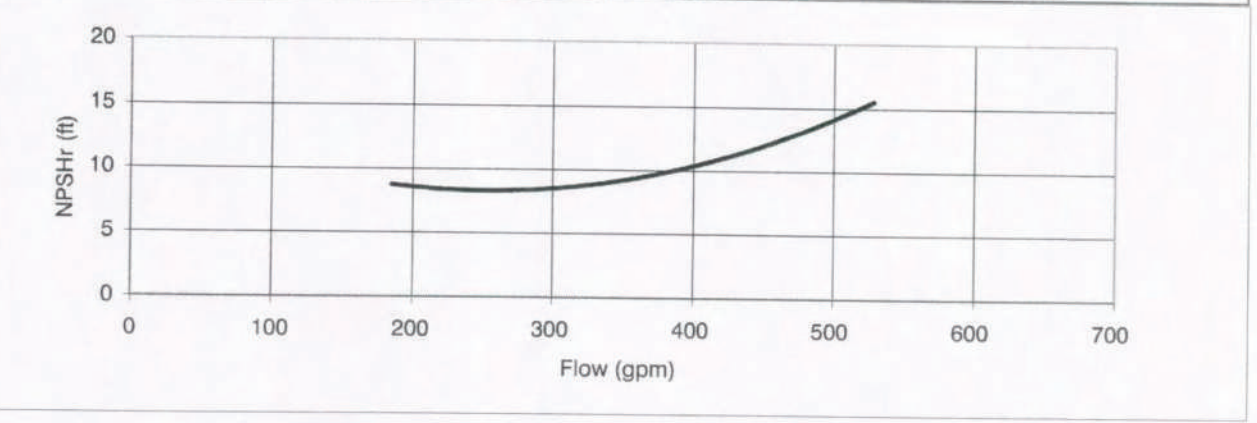
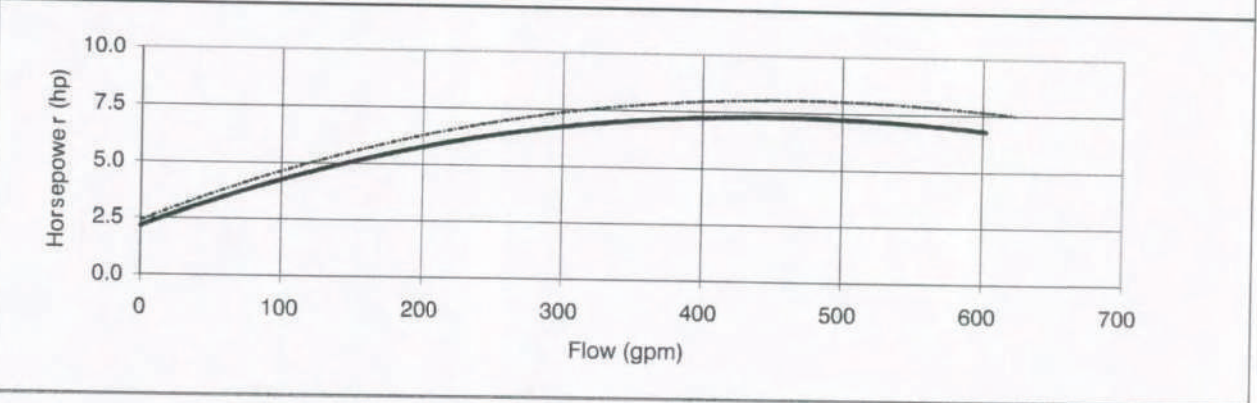
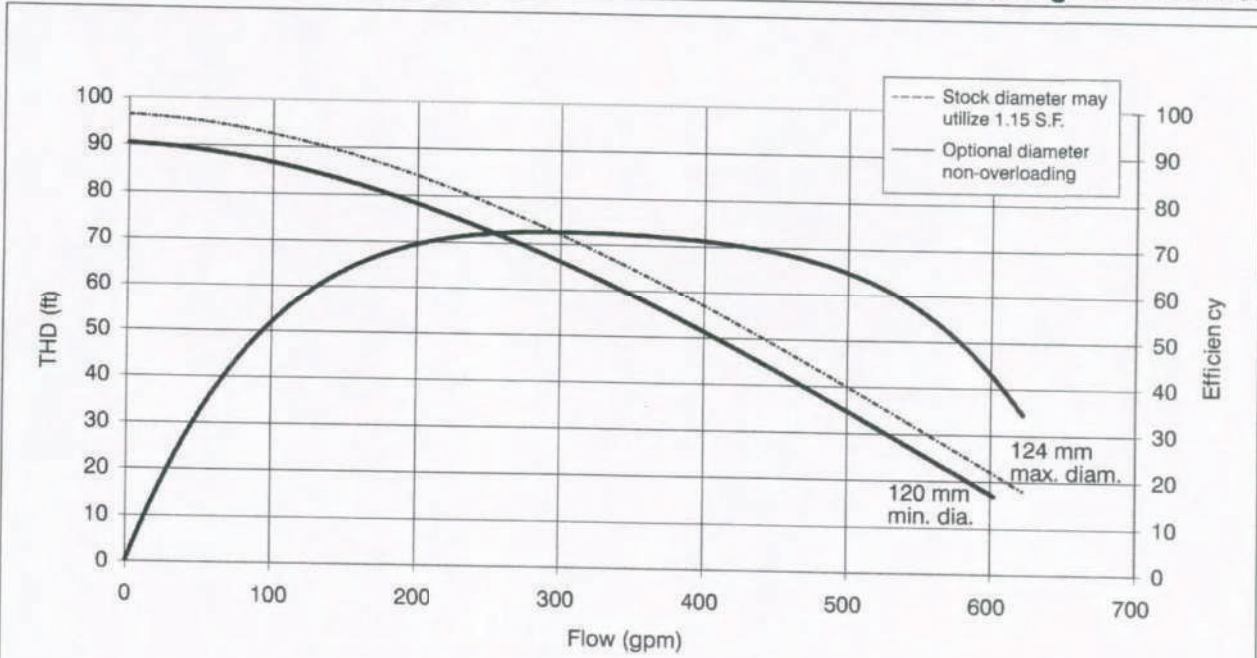



SERIES PS
Performance Curve
MODEL - PSF3002

Synchronous Speed - 3450 RPM

2-1/2" Discharge x 3" Suction

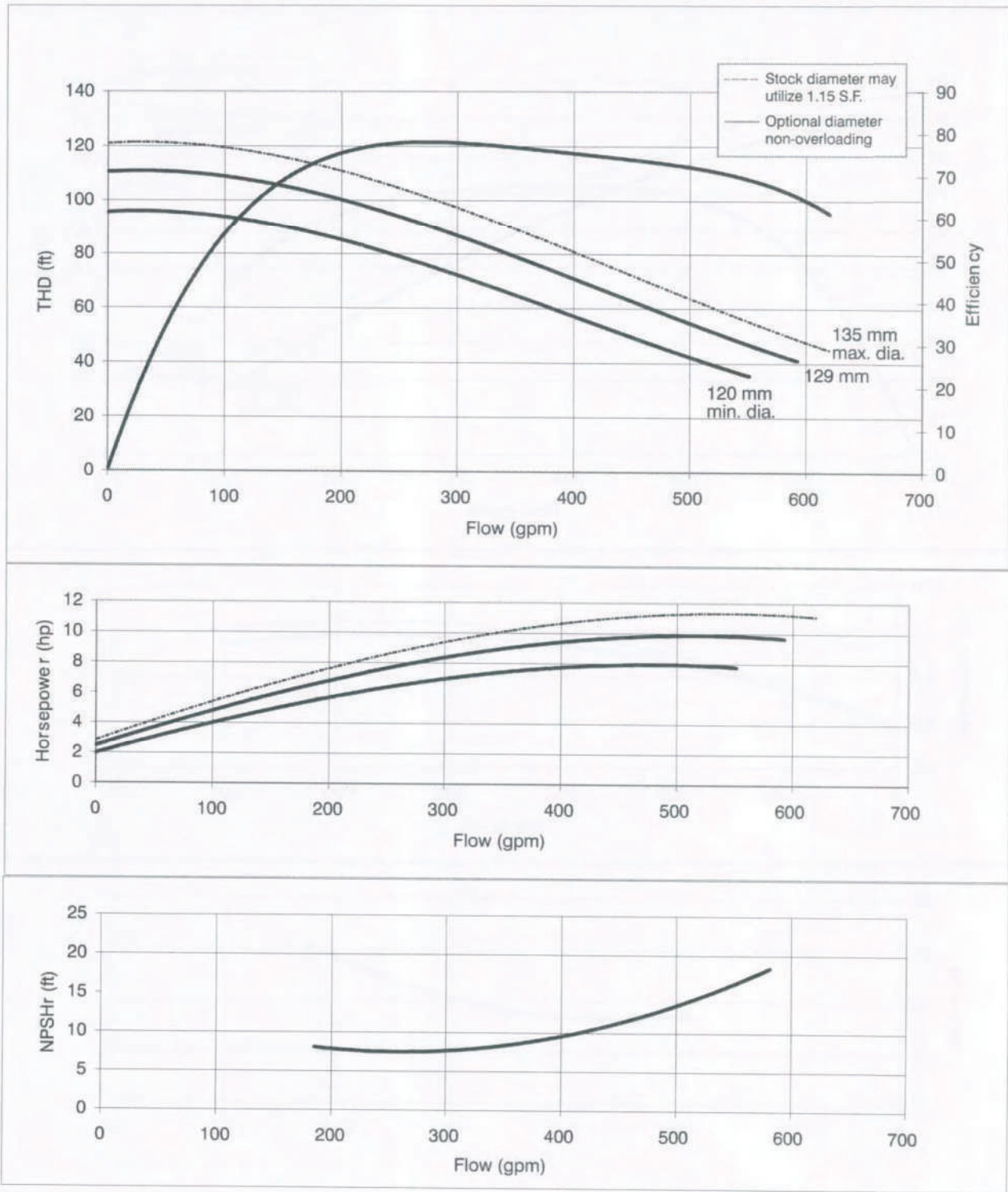



SERIES PS
Performance Curve
MODEL - PSF3003

Synchronous Speed - 3450 RPM

2-1/2" Discharge x 3" Suction

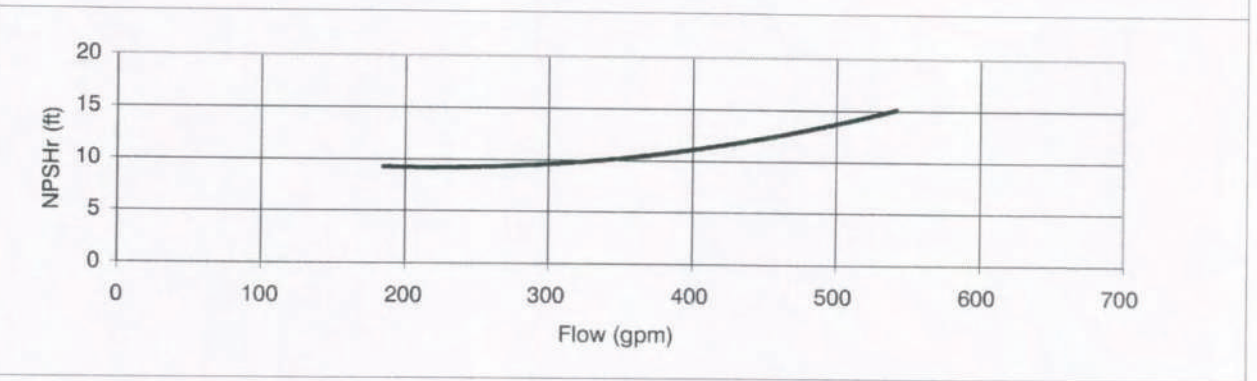
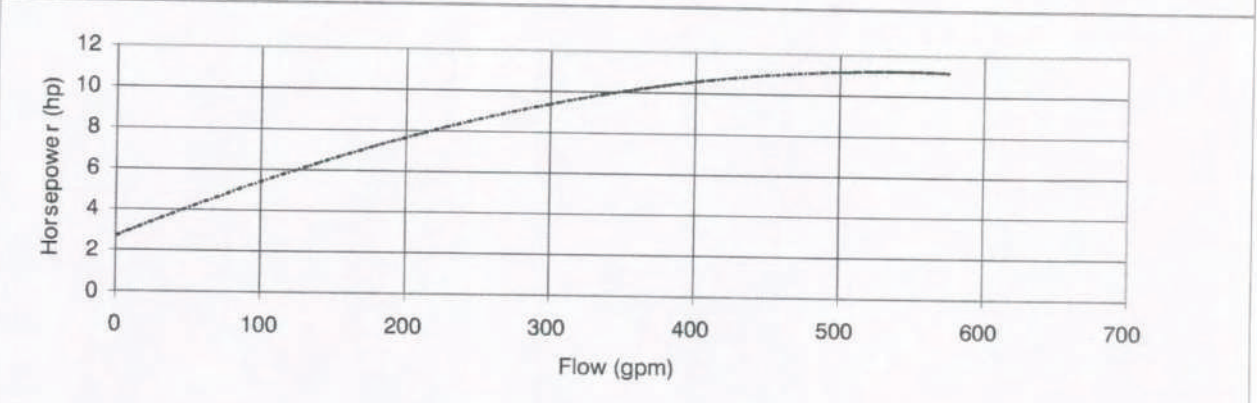
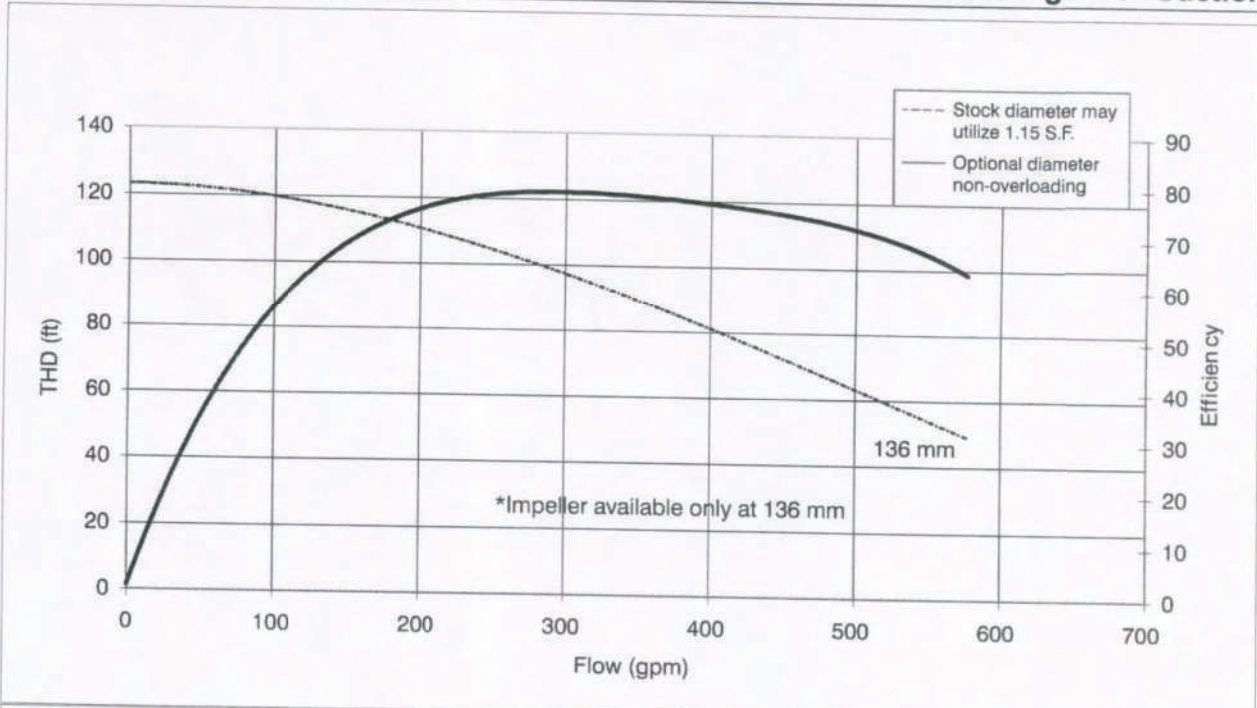



SERIES PS
Performance Curve
MODEL - PSF3004

Synchronous Speed - 3450 RPM

2-1/2" Discharge x 3" Suction

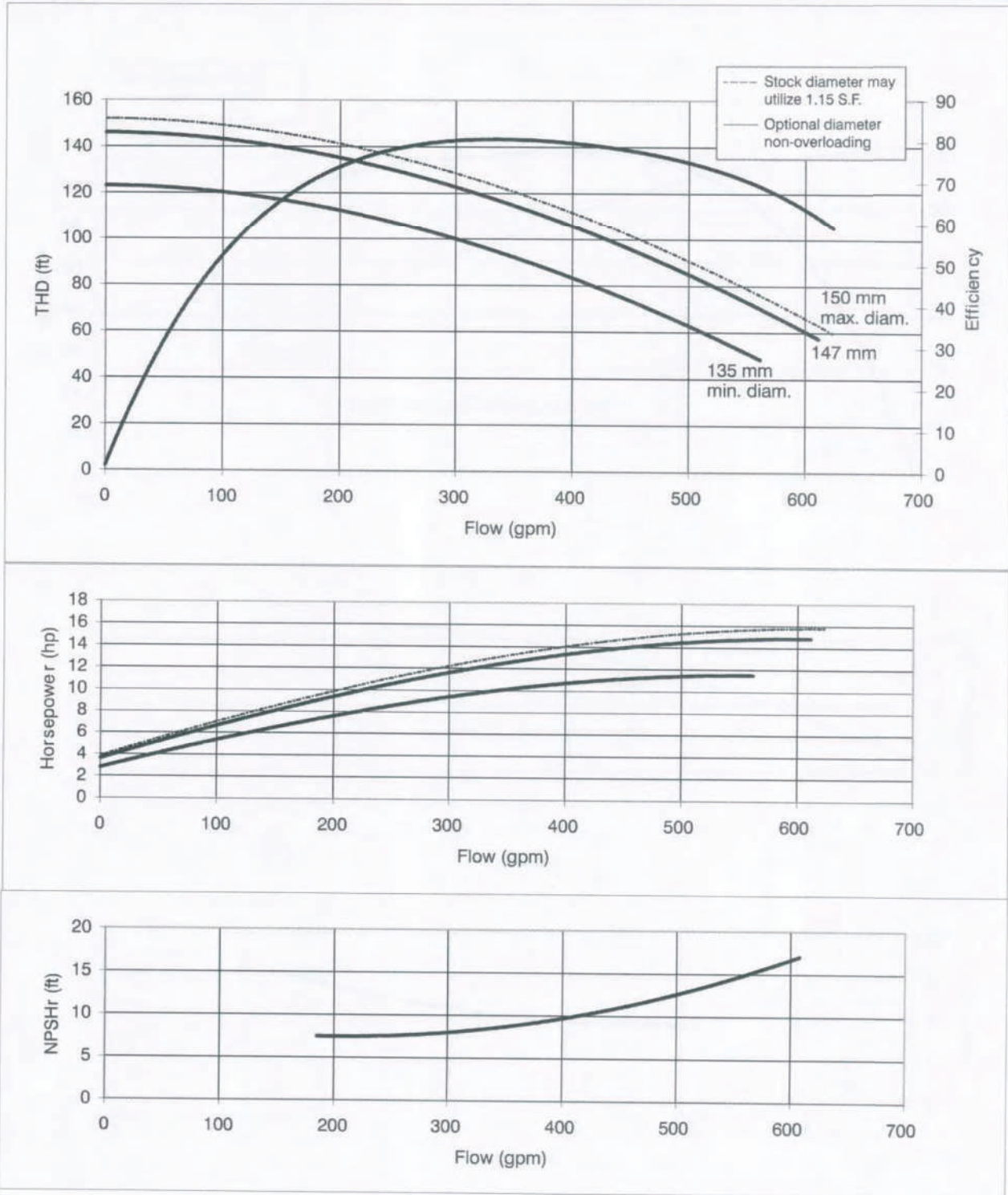



SERIES PS
Performance Curve
MODEL - PSF3005

Synchronous Speed - 3450 RPM

2-1/2" Discharge x 3" Suction

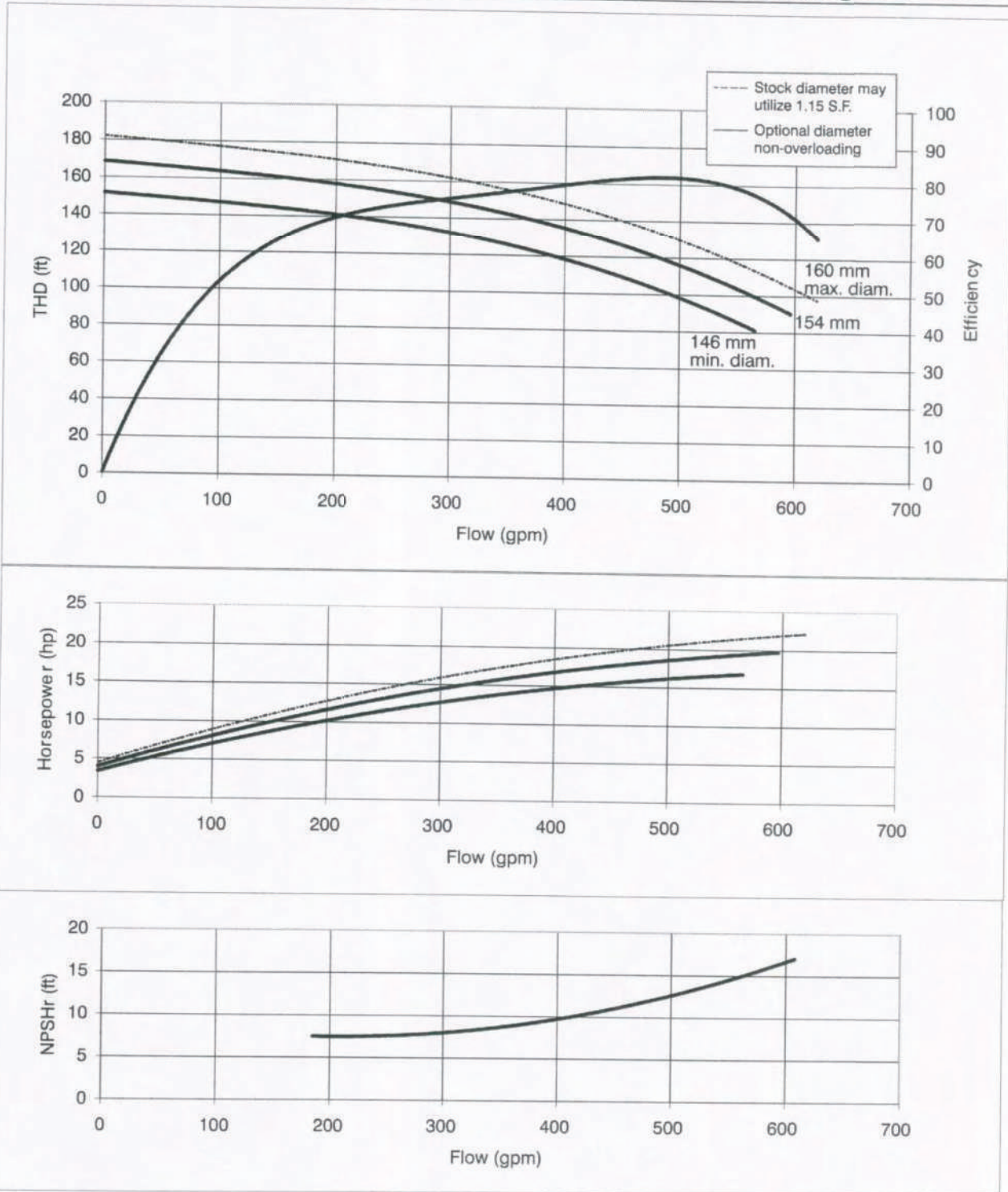



SERIES PS
Performance Curve
MODEL - PSF3006

Synchronous Speed - 3450 RPM

2-1/2" Discharge x 3" Suction

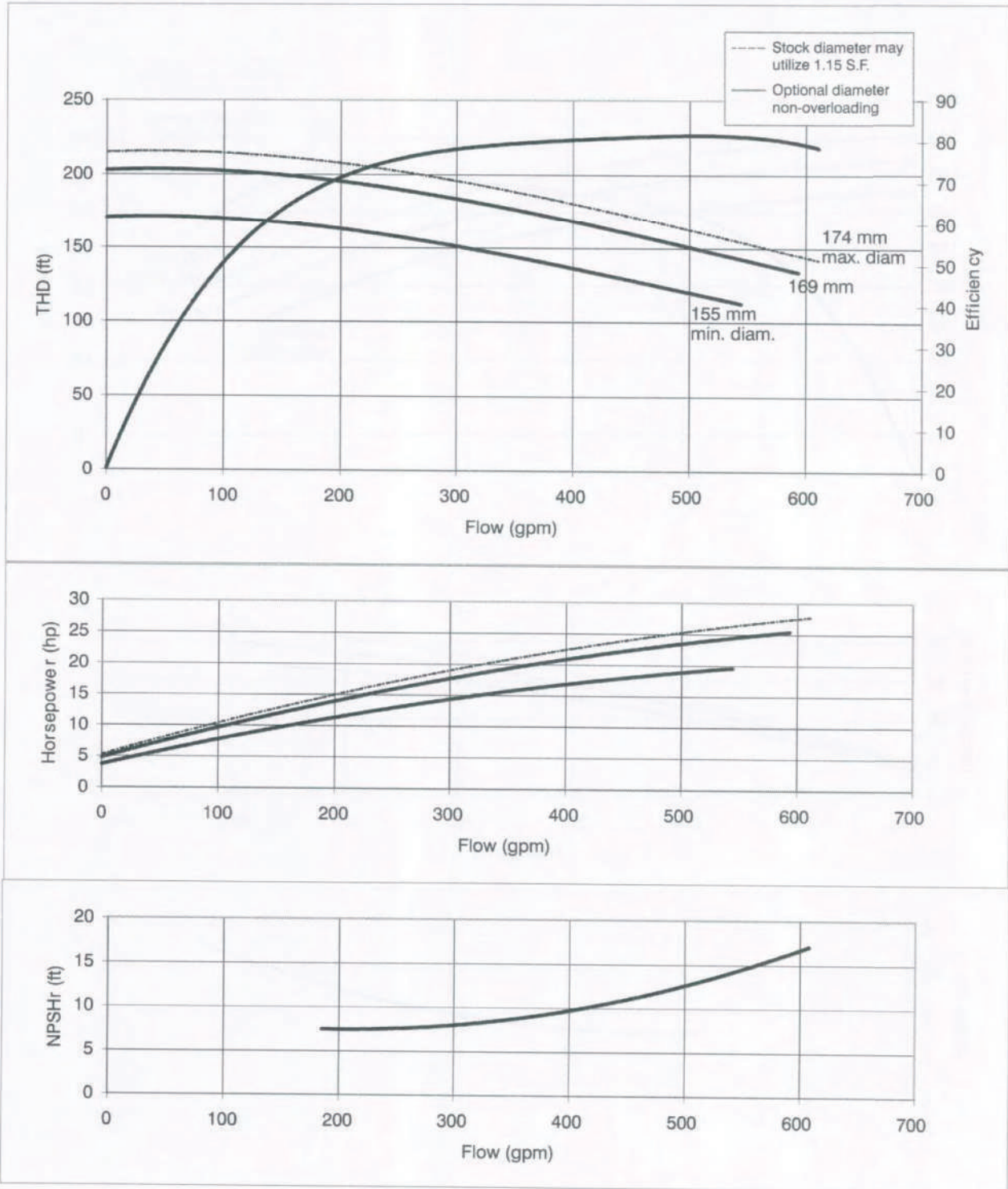



SERIES PS
Performance Curve
MODEL - PSF3007

Synchronous Speed - 3450 RPM

2-1/2" Discharge x 3" Suction

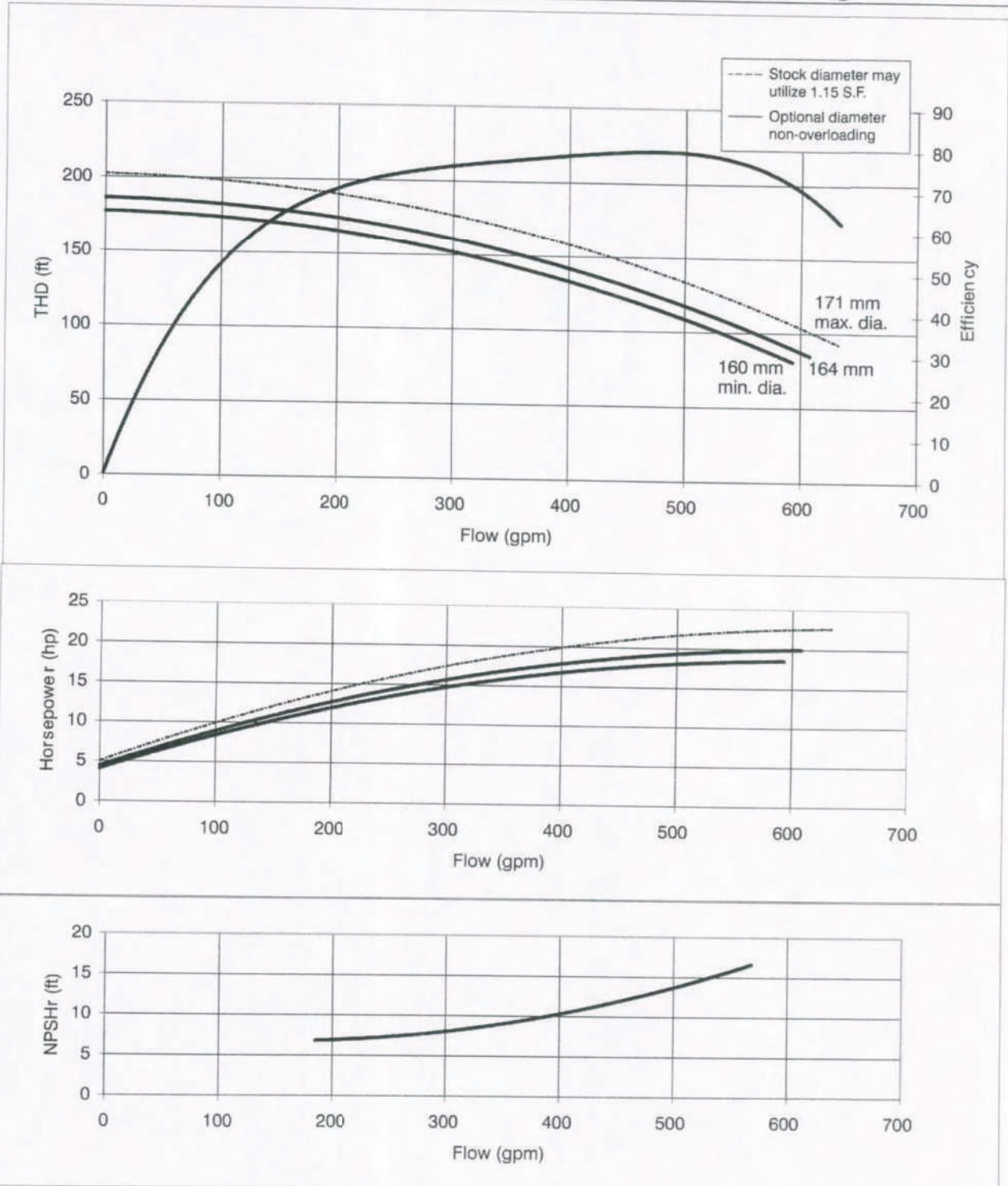



SERIES PS
Performance Curve
MODEL - PSF3008

Synchronous Speed - 3450 RPM

2-1/2" Discharge x 3" Suction

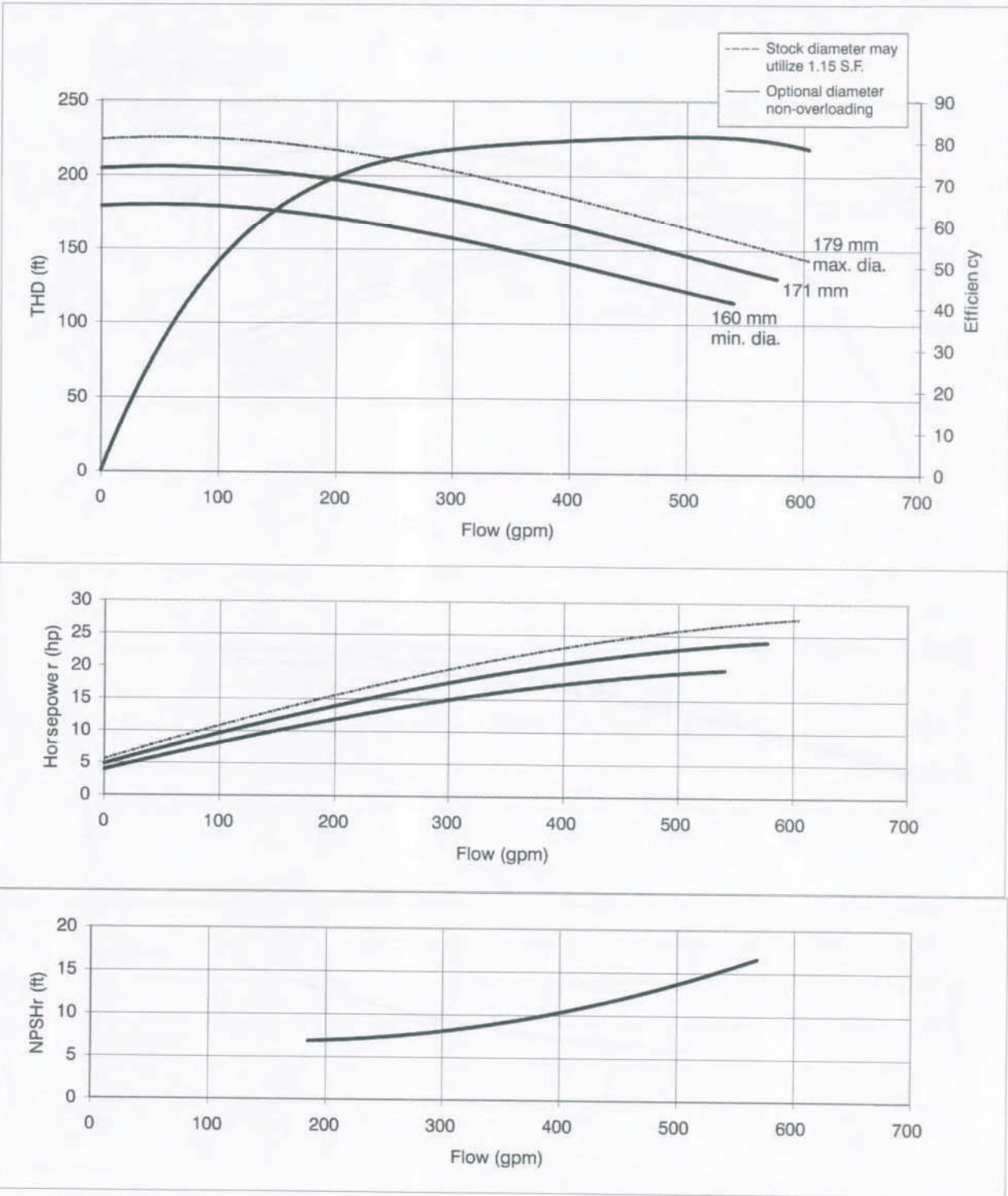



SERIES PS
Performance Curve
MODEL - PSF3009

Synchronous Speed - 3450 RPM

2-1/2" Discharge x 3" Suction

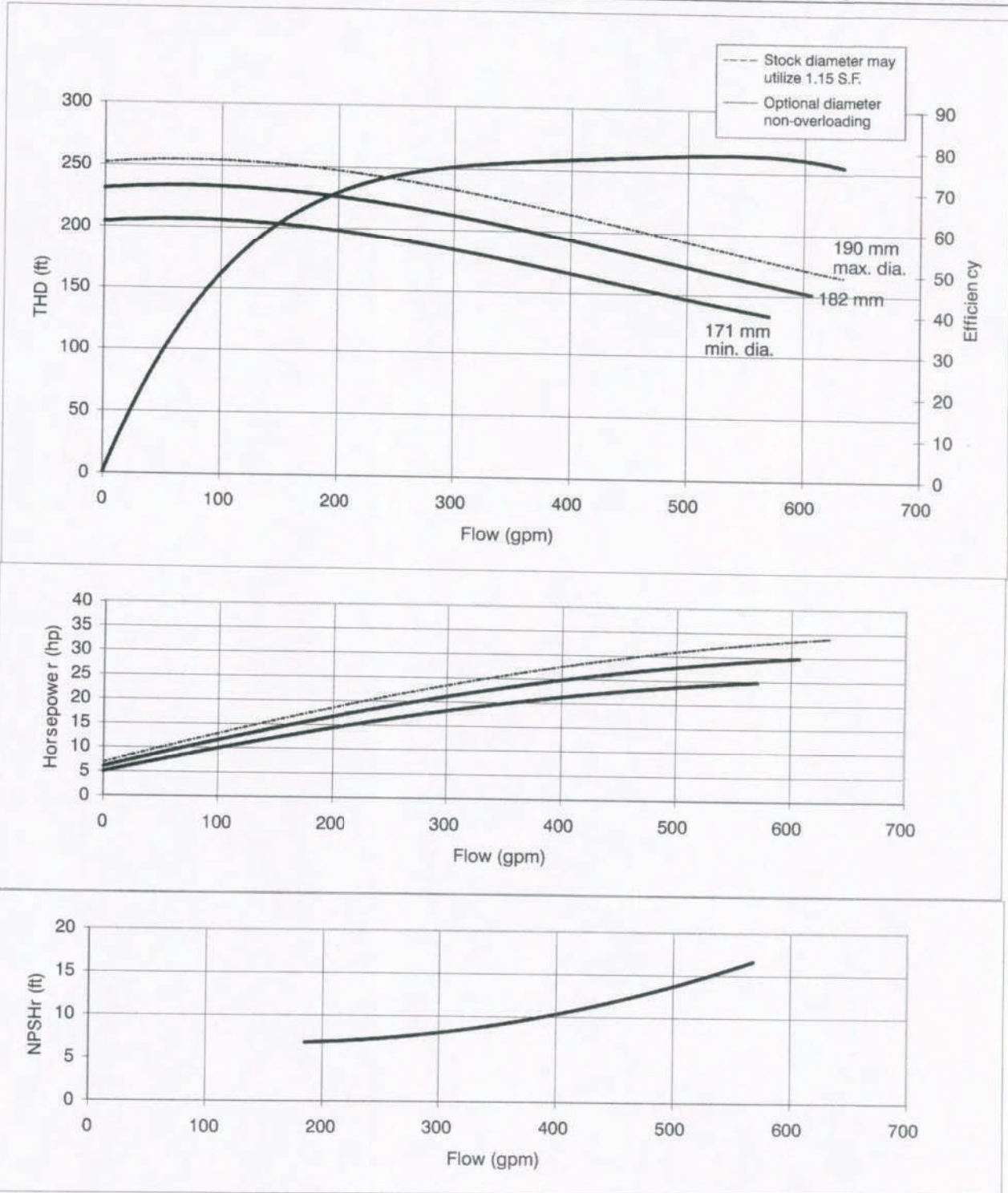



SERIES PS
Parts List
MODEL - PSF701

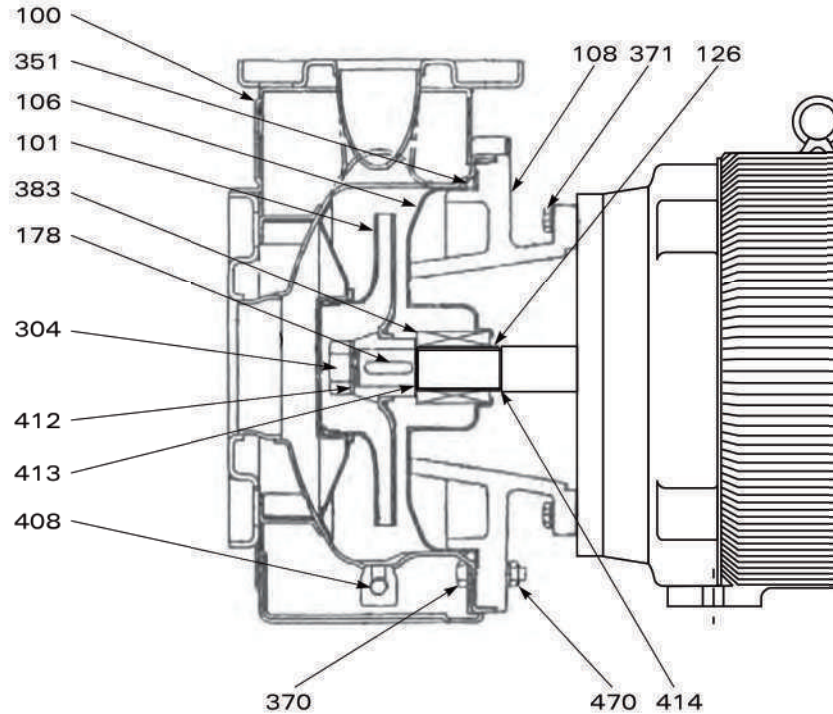

ITEM	QTY REQ'D	DESCRIPTION	MATERIAL	PART NUMBER
100	1	Casing	304 Stainless steel	E-251402201
101	1	Impeller	304 Stainless steel	E-251450866
106	1	Casing cover	304 Stainless steel	E-251438023
108	1	Adapter	Cast Iron	E-240080580
126	1	Shaft sleeve	304 Stainless steel	E-275416013
178	1	Impeller key	Steel	E-316X316
304	1	Impeller bolt	316 SS	E-275440031
351	1	Casing o-ring	Buna	E-160X5.3B
			Viton	E-160X5.3V
370	8	Casing bolt	304 Stainless steel	E-M8X30HH
371	4	Motor bolt	Steel	E-3/8-16X3/4HH
383	1	Mechanical seal	Carbon/Ceramic/Buna	S18-2821-ABN
			Carbon/Ceramic/Viton	S18-2821-AVT
			Carbon/S.S./EPR	S18-2821-CEP
			Carbon/Carbide/Viton	S18-2821-BVT
			Carbide/Carbide/Viton	S18-2821-EVT
408	1	Casing plug	304 Stainless steel	E-363631000
412	1	Impeller gasket	Teflon	E-275476030
413	1	Sleeve gasket	Teflon	E-275476029
414	1	Sleeve gasket	Teflon	E-275476028
470	8	Casing bolt nut	304 Stainless Steel	E-M8HN



SERIES PS
Parts List
MODEL - PSF702

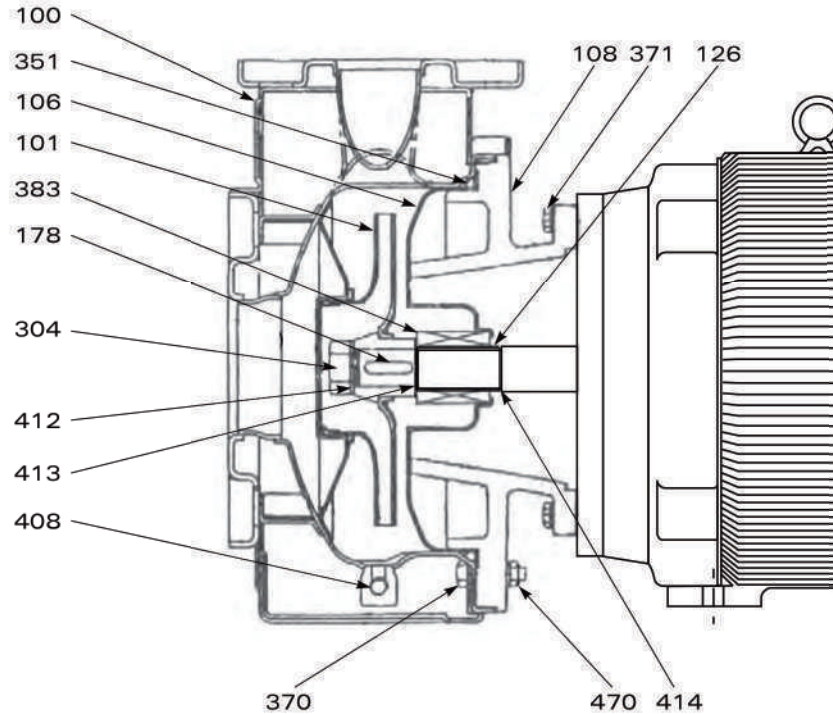

ITEM	QTY REQ'D	DESCRIPTION	MATERIAL	PART NUMBER
100	1	Casing	304 Stainless steel	E-251402202
101	1	Impeller	304 Stainless steel	E-251450867
106	1	Casing cover	304 Stainless steel	E-251438024
108	1	Adapter	Cast Iron	E-240080581
126	1	Shaft sleeve	304 Stainless steel	E-275416013
178	1	Impeller key	Steel	E-316X316
304	1	Impeller bolt	316 SS	E-275440031
351	1	Casing o-ring	Buna	E-190X5.3B
			Viton	E-190X5.3V
370	10	Casing bolt	304 Stainless steel	E-M10X35HH
371	4	Motor bolt	Steel	E-3/8-16X1
383	1	Mechanical seal	Carbon/Ceramic/Buna	S18-2821-ABN
			Carbon/Ceramic/Viton	S18-2821-AVT
			Carbon/S.S./EPR	S18-2821-CEP
			Carbon/Carbide/Viton	S18-2821-BVT
			Carbide/Carbide/Viton	S18-2821-EVT
408	1	Casing plug	304 Stainless steel	E-363631000
412	1	Impeller gasket	Teflon	E-275476030
413	1	Sleeve gasket	Teflon	E-275476029
414	1	Sleeve gasket	Teflon	E-275476028
470	10	Casing bolt nut	304 Stainless Steel	E-M10HN



SERIES PS
Parts List
MODEL - PSF703

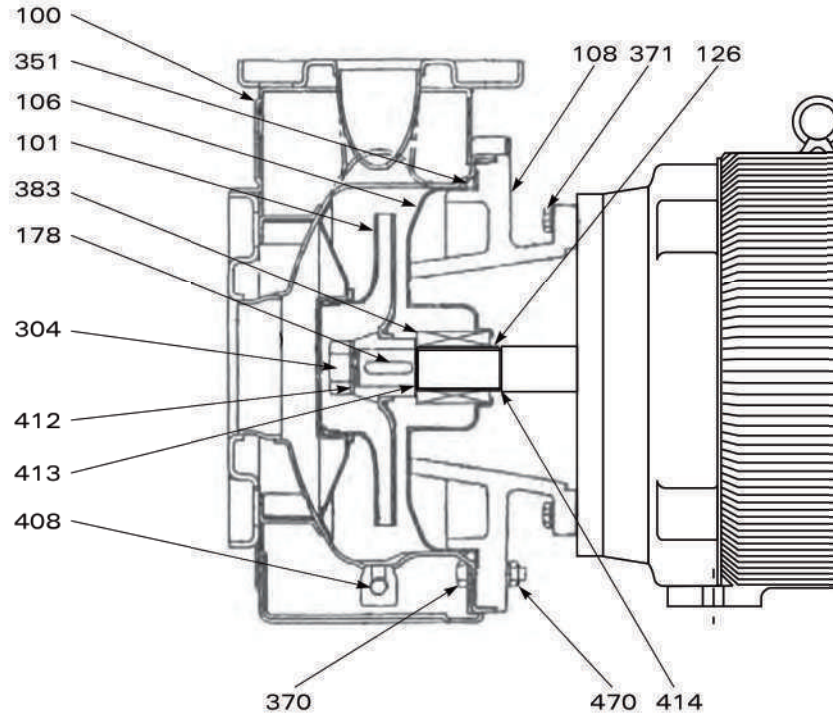

ITEM	QTY REQ'D	DESCRIPTION	MATERIAL	PART NUMBER
100	1	Casing	304 Stainless steel	E-251402202
101	1	Impeller	304 Stainless steel	E-251450868
106	1	Casing cover	304 Stainless steel	E-251438024
108	1	Adapter	Cast Iron	E-240080581
126	1	Shaft sleeve	304 Stainless steel	E-275416013
178	1	Impeller key	Steel	E-316X316
304	1	Impeller bolt	316 SS	E-275440031
351	1	Casing o-ring	Buna Viton	E-190X5.3B E-190X5.3V
370	10	Casing bolt	304 Stainless steel	E-M10X35HH
371	4	Motor bolt	Steel	E-3/8-16X1
383	1	Mechanical seal	Carbon/Ceramic/Buna Carbon/Ceramic/Viton Carbon/S.S./EPR Carbon/Carbide/Viton Carbide/Carbide/Viton	S18-2821-ABN S18-2821-AVT S18-2821-CEP S18-2821-BVT S18-2821-EVT
408	1	Casing plug	304 Stainless steel	E-363631000
412	1	Impeller gasket	Teflon	E-275476030
413	1	Sleeve gasket	Teflon	E-275476029
414	1	Sleeve gasket	Teflon	E-275476028
470	10	Casing bolt nut	304 Stainless Steel	E-M10HN



SERIES PS
Parts List
MODEL - PSF704

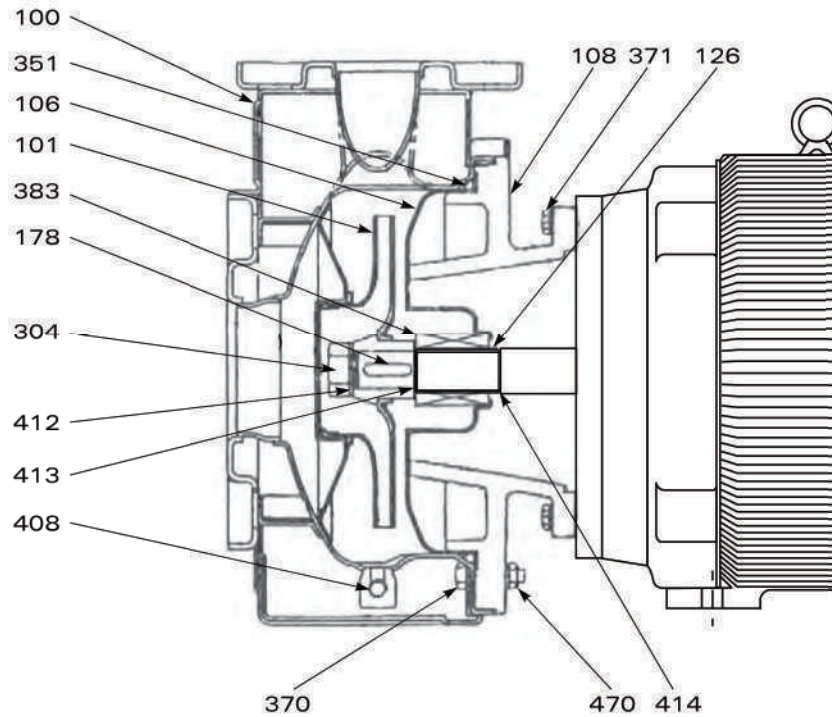

ITEM	QTY REQ'D	DESCRIPTION	MATERIAL	PART NUMBER
100	1	Casing	304 Stainless steel	E-251402203
101	1	Impeller	304 Stainless steel	E-251450869
106	1	Casing cover	304 Stainless steel	E-251402220
108	1	Adapter	C.I. (up to 184JM)	E-240080583
			C.I. (213JM and up)	E-240080584
126	1	Shaft sleeve	304 Stainless steel	E-275416013
178	1	Impeller key	Steel	E-316X316
304	1	Impeller bolt	316 SS	E-275440031
351	1	Casing o-ring	Buna	E-230X5.3B
			Viton	E-230X5.3V
370	12	Casing bolt	304 Stainless steel	E-M10X30HH
371	4	Motor bolt	Steel	E-1/2-13X1-1/2
383	1	Mechanical seal	Carbon/Ceramic/Buna	S18-2821-ABN
			Carbon/Ceramic/Viton	S18-2821-AVT
			Carbon/S.S./EPR	S18-2821-CEP
			Carbon/Carbide/Viton	S18-2821-BVT
			Carbide/Carbide/Viton	S18-2821-EVT
408	1	Casing plug	304 Stainless steel	E-363631000
412	1	Impeller gasket	Teflon	E-275476030
413	1	Sleeve gasket	Teflon	E-275476029
414	1	Sleeve gasket	Teflon	E-275476028
470	12	Casing bolt nut	304 Stainless Steel	E-M10HN



SERIES PS
Parts List
MODEL - PSF705

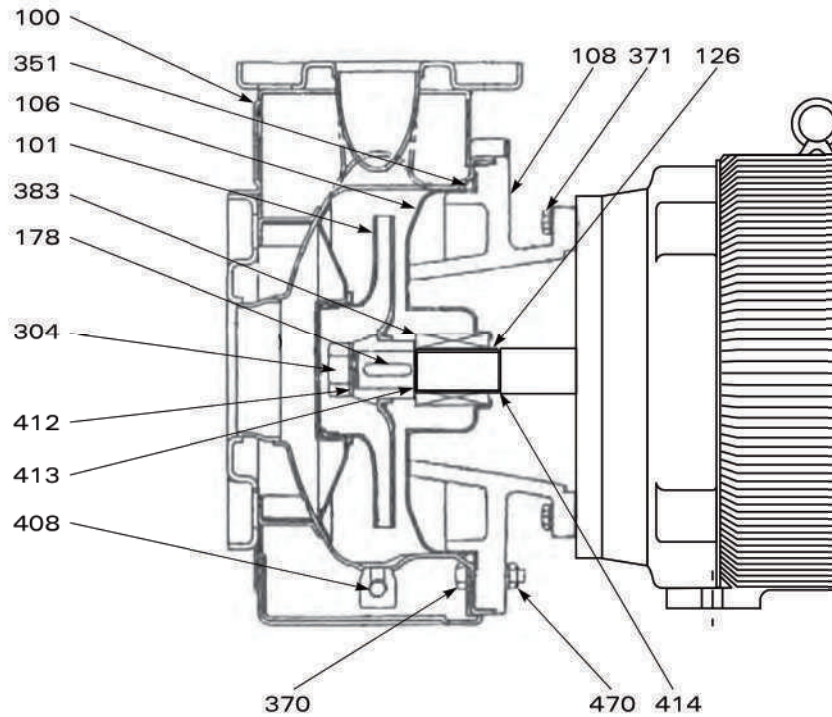

ITEM	QTY REQ'D	DESCRIPTION	MATERIAL	PART NUMBER
100	1	Casing	304 Stainless steel	E-251402203
101	1	Impeller	304 Stainless steel	E-251450870
106	1	Casing cover	304 Stainless steel	E-251402220
108	1	Adapter	C.I. (up to 184JM)	E-240080583
			C.I. (213JM and up)	E-240080584
126	1	Shaft sleeve	304 Stainless steel	E-275416013
178	1	Impeller key	Steel	E-316X316
304	1	Impeller bolt	316 SS	E-275440031
351	1	Casing o-ring	Buna	E-230X5.3B
			Viton	E-230X5.3V
370	12	Casing bolt	304 Stainless steel	E-M10X35HH
371	4	Motor bolt	Steel	E-1/2-13X1-1/2
383	1	Mechanical seal	Carbon/Ceramic/Buna	S18-2821-ABN
			Carbon/Ceramic/Viton	S18-2821-AVT
			Carbon/S.S./EPR	S18-2821-CEP
			Carbon/Carbide/Viton	S18-2821-BVT
			Carbide/Carbide/Viton	S18-2821-EVT
408	1	Casing plug	304 Stainless steel	E-363631000
412	1	Impeller gasket	Teflon	E-275476030
413	1	Sleeve gasket	Teflon	E-275476029
414	1	Sleeve gasket	Teflon	E-275476028
470	12	Casing bolt nut	304 Stainless Steel	E-M10HN



SERIES PS
Parts List
MODEL - PSF1201

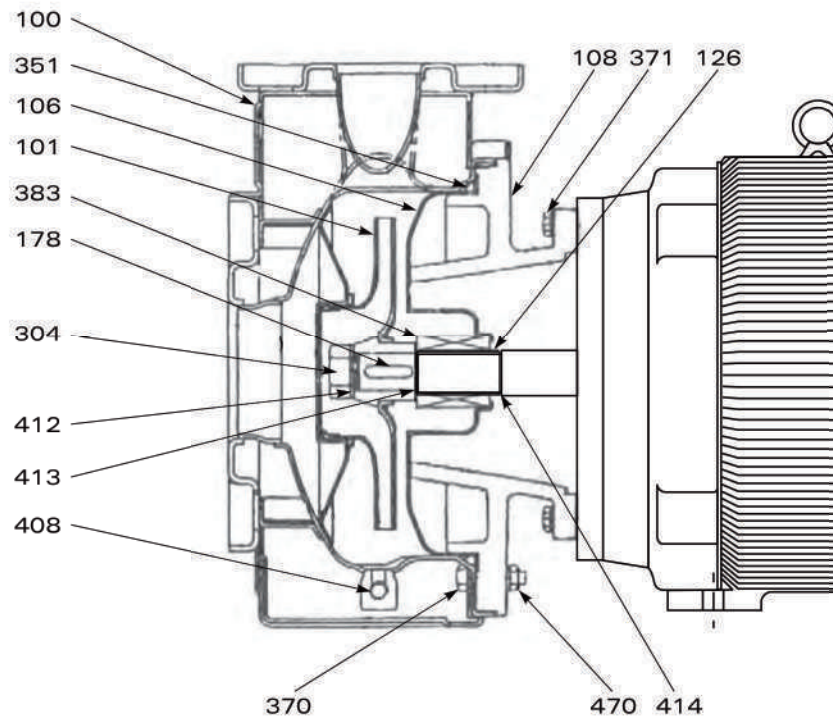

ITEM	QTY REQ'D	DESCRIPTION	MATERIAL	PART NUMBER
100	1	Casing	304 Stainless steel	E-251402204
101	1	Impeller	304 Stainless steel	E-251450871
106	1	Casing cover	304 Stainless steel	E-251438023
108	1	Adapter	Cast Iron	E-240080580
126	1	Shaft sleeve	304 Stainless steel	E-275416013
178	1	Impeller key	Steel	E-316X316
304	1	Impeller bolt	316 SS	E-275440031
351	1	Casing o-ring	Buna	E-160X5.3B
			Viton	E-160X5.3V
370	8	Casing bolt	304 Stainless steel	E-M8X30HH
371	4	Motor bolt	Steel	E-3/8-16X3/4HH
383	1	Mechanical seal	Carbon/Ceramic/Buna	S18-2821-ABN
			Carbon/Ceramic/Viton	S18-2821-AVT
			Carbon/S.S./EPR	S18-2821-CEP
			Carbon/Carbide/Viton	S18-2821-BVT
			Carbide/Carbide/Viton	S18-2821-EVT
408	1	Casing plug	304 Stainless steel	E-363631000
412	1	Impeller gasket	Teflon	E-275476030
413	1	Sleeve gasket	Teflon	E-275476029
414	1	Sleeve gasket	Teflon	E-275476028
470	8	Casing bolt nut	304 Stainless Steel	E-M8HN



SERIES PS
Parts List
MODEL - PSF1202

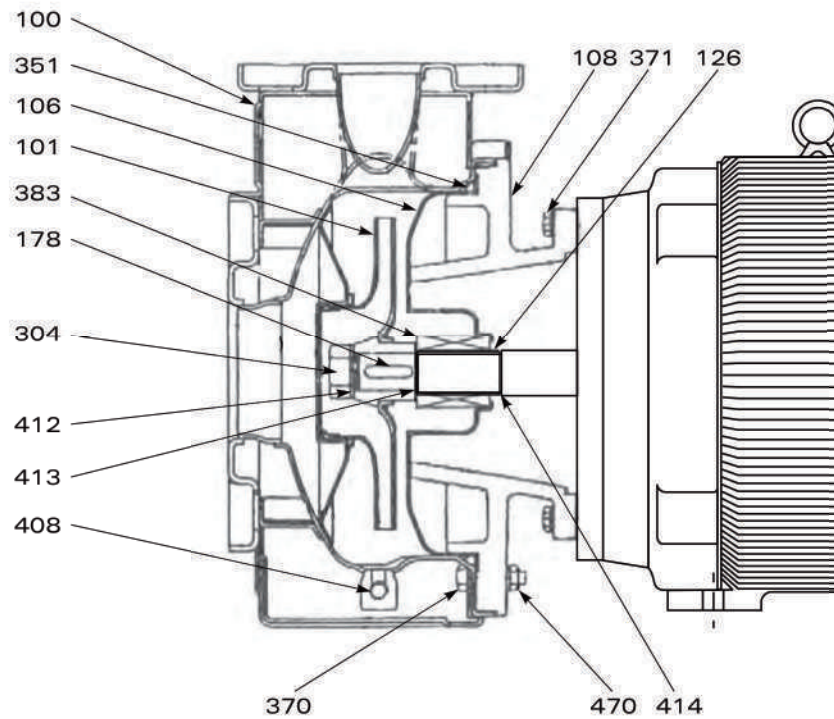

ITEM	QTY REQ'D	DESCRIPTION	MATERIAL	PART NUMBER
100	1	Casing	304 Stainless steel	E-251402204
101	1	Impeller	304 Stainless steel	E-251450872
106	1	Casing cover	304 Stainless steel	E-251438023
108	1	Adapter	Cast Iron	E-240080580
126	1	Shaft sleeve	304 Stainless steel	E-275416013
178	1	Impeller key	Steel	E-316X316
304	1	Impeller bolt	316 SS	E-275440031
351	1	Casing o-ring	Buna	E-160X5.3B
			Viton	E-160X5.3V
370	8	Casing bolt	304 Stainless steel	E-M8X30HH
371	4	Motor bolt	Steel	E-3/8-16X3/4HH
383	1	Mechanical seal	Carbon/Ceramic/Buna	S18-2821-ABN
			Carbon/Ceramic/Viton	S18-2821-AVT
			Carbon/S.S./EPR	S18-2821-CEP
			Carbon/Carbide/Viton	S18-2821-BVT
			Carbide/Carbide/Viton	S18-2821-EVT
408	1	Casing plug	304 Stainless steel	E-363631000
412	1	Impeller gasket	Teflon	E-275476030
413	1	Sleeve gasket	Teflon	E-275476029
414	1	Sleeve gasket	Teflon	E-275476028
470	8	Casing bolt nut	304 Stainless Steel	E-M8HN



SERIES PS
Parts List
MODEL - PSF1203

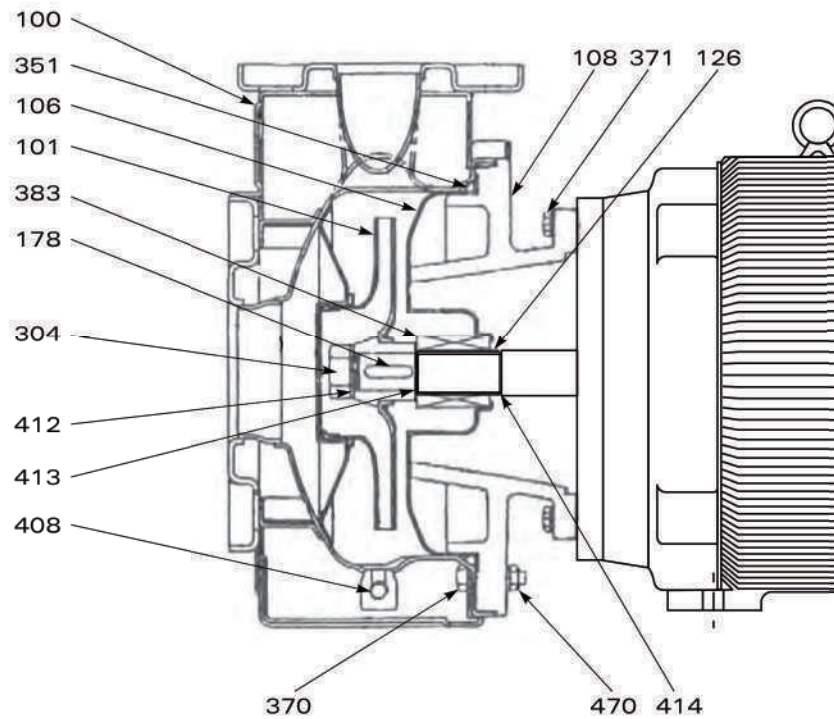

ITEM	QTY REQ'D	DESCRIPTION	MATERIAL	PART NUMBER
100	1	Casing	304 Stainless steel	E-251402205
101	1	Impeller	304 Stainless steel	E-251450873
106	1	Casing cover	304 Stainless steel	E-251438024
108	1	Adapter	C.I. (up to 184JM)	E-240080581
			C.I. (213JM and up)	E-240080582
126	1	Shaft sleeve	304 Stainless steel	E-275416013
178	1	Impeller key	Steel	E-316X316
304	1	Impeller bolt	316 SS	E-275440031
351	1	Casing o-ring	Buna	E-190X5.3B
			Viton	E-190X5.3V
370	10	Casing bolt	304 Stainless steel	E-M10X35HH
371	4	Motor bolt	Steel	E-3/8-16X1-3/4
383	1	Mechanical seal	Carbon/Ceramic/Buna	S18-2821-ABN
			Carbon/Ceramic/Viton	S18-2821-AVT
			Carbon/S.S./EPR	S18-2821-CEP
			Carbon/Carbide/Viton	S18-2821-BVT
			Carbide/Carbide/Viton	S18-2821-EVT
408	1	Casing plug	304 Stainless steel	E-363631000
412	1	Impeller gasket	Teflon	E-275476030
413	1	Sleeve gasket	Teflon	E-275476029
414	1	Sleeve gasket	Teflon	E-275476028
470	10	Casing bolt nut	304 Stainless Steel	E-M10HN



SERIES PS
Parts List
MODEL - PSF1204

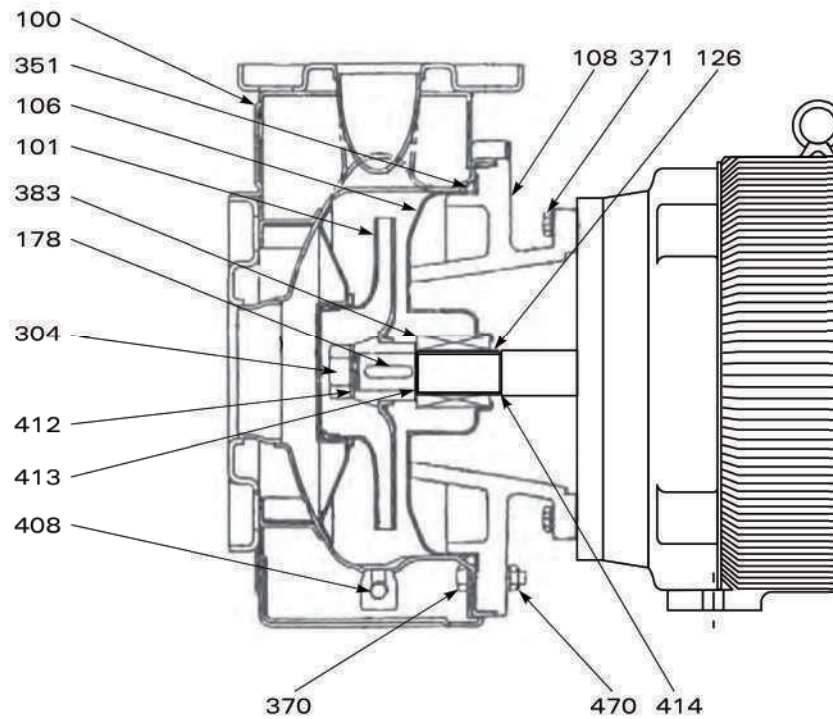

ITEM	QTY REQ'D	DESCRIPTION	MATERIAL	PART NUMBER
100	1	Casing	304 Stainless steel	E-251402205
101	1	Impeller	304 Stainless steel	E-251450874
106	1	Casing cover	304 Stainless steel	E-251438024
108	1	Adapter	C.I. (up to 184JM)	E-240080581
			C.I. (213JM and up)	E-240080582
126	1	Shaft sleeve	304 Stainless steel	E-275416013
178	1	Impeller key	Steel	E-316X316
304	1	Impeller bolt	316 SS	E-275440031
351	1	Casing o-ring	Buna	E-190X5.3B
			Viton	E-190X5.3V
370	10	Casing bolt	304 Stainless steel	E-M10X35HH
371	4	Motor bolt	Steel	E-1/2-13X1-3/4
383	1	Mechanical seal	Carbon/Ceramic/Buna	S18-2821-ABN
			Carbon/Ceramic/Viton	S18-2821-AVT
			Carbon/S.S./EPR	S18-2821-CEP
			Carbon/Carbide/Viton	S18-2821-BVT
			Carbide/Carbide/Viton	S18-2821-EVT
408	1	Casing plug	304 Stainless steel	E-363631000
412	1	Impeller gasket	Teflon	E-275476030
413	1	Sleeve gasket	Teflon	E-275476029
414	1	Sleeve gasket	Teflon	E-275476028
470	10	Casing bolt nut	304 Stainless Steel	E-M10HN



SERIES PS
Parts List
MODEL - PSF1205

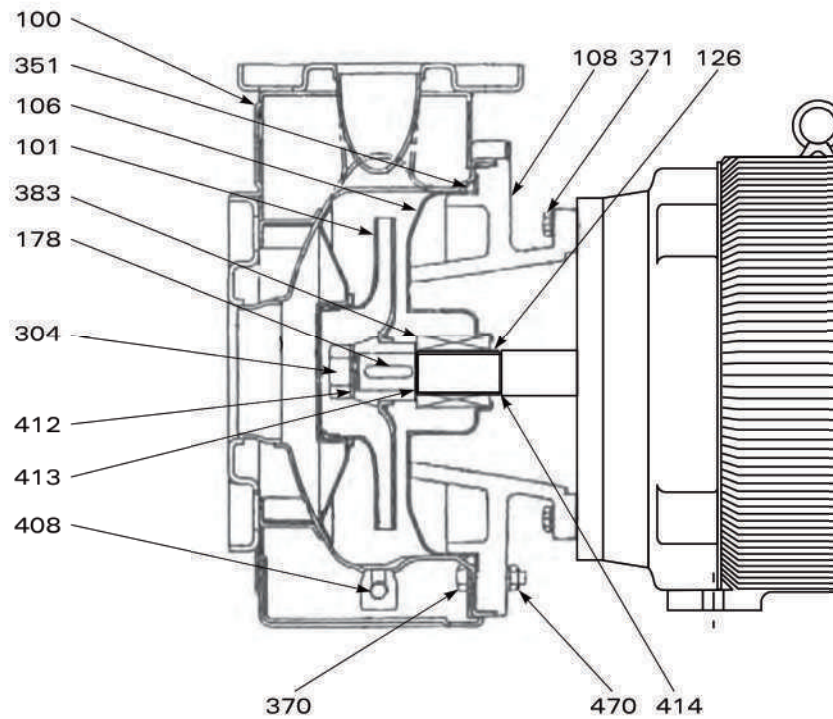

ITEM	QTY REQ'D	DESCRIPTION	MATERIAL	PART NUMBER
100	1	Casing	304 Stainless steel	E-251402206
101	1	Impeller	304 Stainless steel	E-251450875
106	1	Casing cover	304 Stainless steel	E-251402220
108	1	Adapter	C.I. (up to 184JM)	E-240080583
			C.I. (213JM and up)	E-240080584
126	1	Shaft sleeve	304 Stainless steel	E-275416013
178	1	Impeller key	Steel	E-316X316
304	1	Impeller bolt	316 SS	E-275440031
351	1	Casing o-ring	Buna	E-230X5.3B
			Viton	E-230X5.3V
370	12	Casing bolt	304 Stainless steel	E-M10X35HH
371	4	Motor bolt	Steel	E-1/2-13X1-1/2
383	1	Mechanical seal	Carbon/Ceramic/Buna	S18-2821-ABN
			Carbon/Ceramic/Viton	S18-2821-AVT
			Carbon/S.S./EPR	S18-2821-CEP
			Carbon/Carbide/Viton	S18-2821-BVT
			Carbide/Carbide/Viton	S18-2821-EVT
408	1	Casing plug	304 Stainless steel	E-363631000
412	1	Impeller gasket	Teflon	E-275476030
413	1	Sleeve gasket	Teflon	E-275476029
414	1	Sleeve gasket	Teflon	E-275476028
470	12	Casing bolt nut	304 Stainless Steel	E-M10HN



SERIES PS Parts List MODEL - PSF1206

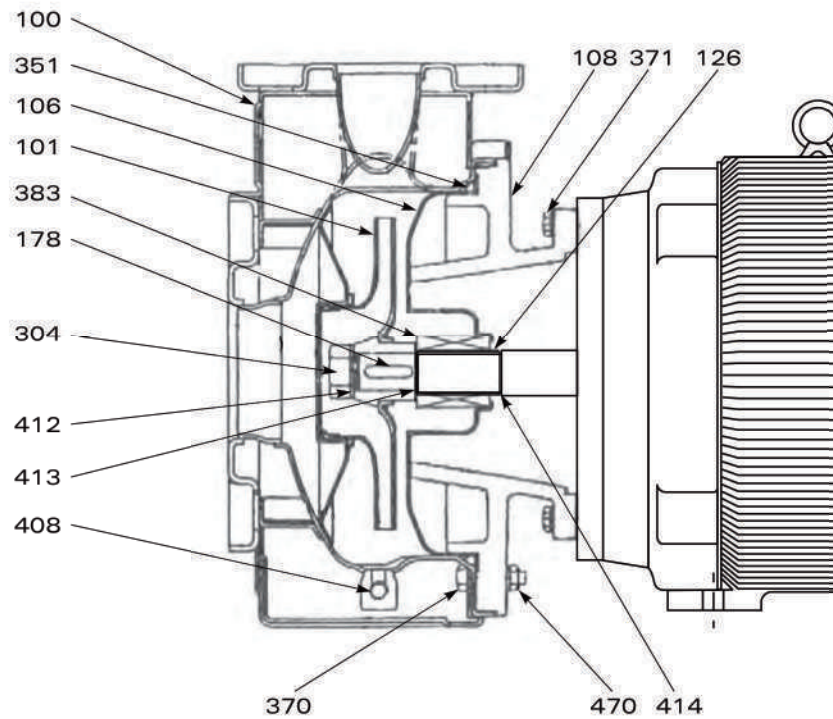

ITEM	QTY REQ'D	DESCRIPTION	MATERIAL	PART NUMBER
100	1	Casing	304 Stainless steel	E-251402206
101	1	Impeller	304 Stainless steel	E-251450876
106	1	Casing cover	304 Stainless steel	E-251402220
108	1	Adapter	C.I. (up to 184JM)	E-240080583
			C.I. (213JM and up)	E-240080584
126	1	Shaft sleeve	304 Stainless steel	E-275416013
178	1	Impeller key	Steel	E-316X316
304	1	Impeller bolt	316 SS	E-275440031
351	1	Casing o-ring	Buna	E-230X5.3B
			Viton	E-230X5.3V
370	12	Casing bolt	304 Stainless steel	E-M10X35HH
371	4	Motor bolt	Steel	E-1/2-13X1-1/2
383	1	Mechanical seal	Carbon/Ceramic/Buna	S18-2821-ABN
			Carbon/Ceramic/Viton	S18-2821-AVT
			Carbon/S.S./EPR	S18-2821-CEP
			Carbon/Carbide/Viton	S18-2821-BVT
			Carbide/Carbide/Viton	S18-2821-EVT
408	1	Casing plug	304 Stainless steel	E-363631000
412	1	Impeller gasket	Teflon	E-275476030
413	1	Sleeve gasket	Teflon	E-275476029
414	1	Sleeve gasket	Teflon	E-275476028
470	12	Casing bolt nut	304 Stainless Steel	E-M10HN



SERIES PS
Parts List
MODEL - PSF2001

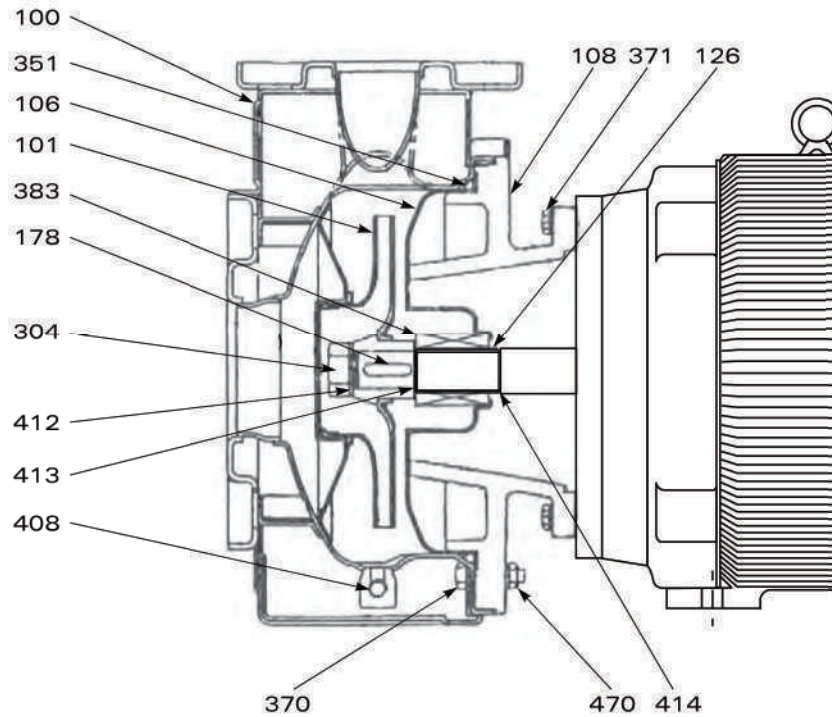

ITEM	QTY REQ'D	DESCRIPTION	MATERIAL	PART NUMBER
100	1	Casing	304 Stainless steel	E-251402207
101	1	Impeller	304 Stainless steel	E-251450877
106	1	Casing cover	304 Stainless steel	E-251438024
108	1	Adapter	C.I. (up to 184JM)	E-240080581
			C.I. (213JM and up)	E-240080582
126	1	Shaft sleeve	304 Stainless steel	E-275416013
178	1	Impeller key	Steel	E-316X316
304	1	Impeller bolt	316 SS	E-275440031
351	1	Casing o-ring	Buna	E-190X5.3B
			Viton	E-190X5.3V
370	10	Casing bolt	304 Stainless steel	E-M10X35HH
371	4	Motor bolt	Steel	E-1/2-13X1-3/4
383	1	Mechanical seal	Carbon/Ceramic/Buna	S18-2821-ABN
			Carbon/Ceramic/Viton	S18-2821-AVT
			Carbon/S.S./EPR	S18-2821-CEP
			Carbon/Carbide/Viton	S18-2821-BVT
			Carbide/Carbide/Viton	S18-2821-EVT
408	1	Casing plug	304 Stainless steel	E-363631000
412	1	Impeller gasket	Teflon	E-275476030
413	1	Sleeve gasket	Teflon	E-275476029
414	1	Sleeve gasket	Teflon	E-275476028
470	10	Casing bolt nut	304 Stainless Steel	E-M10HN



SERIES PS Parts List MODEL - PSF2002

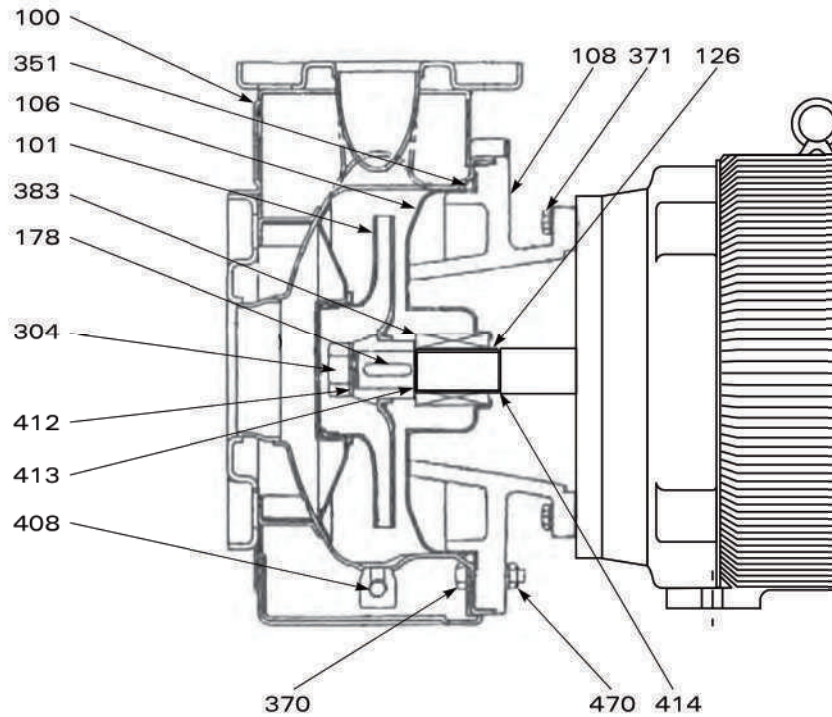

ITEM	QTY REQ'D	DESCRIPTION	MATERIAL	PART NUMBER
100	1	Casing	304 Stainless steel	E-251402207
101	1	Impeller	304 Stainless steel	E-251450878
106	1	Casing cover	304 Stainless steel	E-251438024
108	1	Adapter	C.I. (up to 184JM)	E-240080581
			C.I. (213JM and up)	E-240080582
126	1	Shaft sleeve	304 Stainless steel	E-275416013
178	1	Impeller key	Steel	E-316X316
304	1	Impeller bolt	316 SS	E-275440031
351	1	Casing o-ring	Buna	E-190X5.3B
			Viton	E-190X5.3V
370	10	Casing bolt	304 Stainless steel	E-M10X35HH
371	4	Motor bolt	Steel	E-1/2-13X1-3/4
383	1	Mechanical seal	Carbon/Ceramic/Buna	S18-2821-ABN
			Carbon/Ceramic/Viton	S18-2821-AVT
			Carbon/S.S./EPR	S18-2821-CEP
			Carbon/Carbide/Viton	S18-2821-BVT
			Carbide/Carbide/Viton	S18-2821-EVT
408	1	Casing plug	304 Stainless steel	E-363631000
412	1	Impeller gasket	Teflon	E-275476030
413	1	Sleeve gasket	Teflon	E-275476029
414	1	Sleeve gasket	Teflon	E-275476028
470	10	Casing bolt nut	304 Stainless Steel	E-M10HN



SERIES PS
Parts List
MODEL - PSF2003

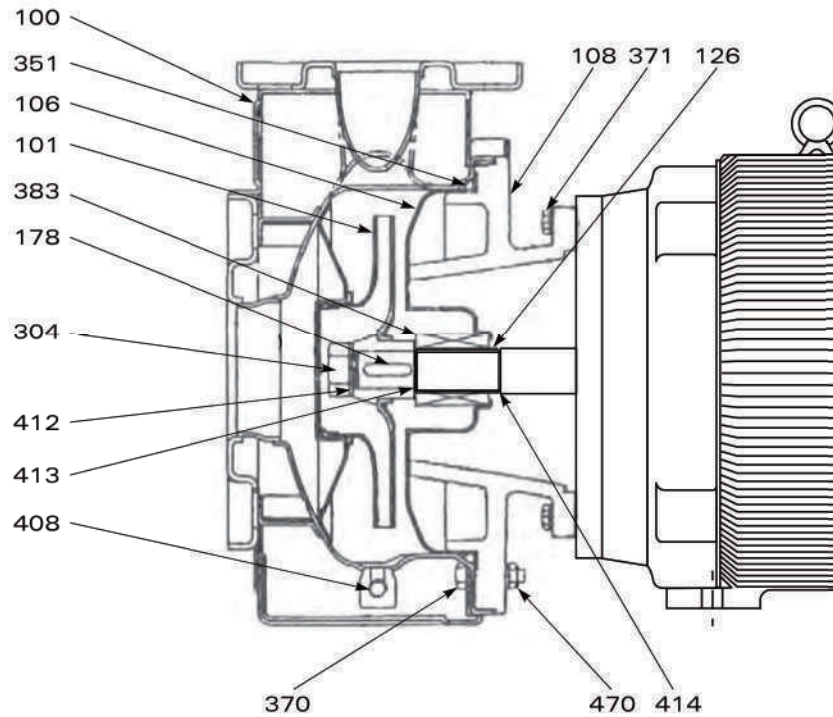

ITEM	QTY REQ'D	DESCRIPTION	MATERIAL	PART NUMBER
100	1	Casing	304 Stainless steel	E-251402208
101	1	Impeller	304 Stainless steel	E-251450879
106	1	Casing cover	304 Stainless steel	E-251402221
108	1	Adapter	C.I. (up to 184JM)	E-240080583
			C.I. (213JM and up)	E-240080584
126	1	Shaft sleeve	304 Stainless steel	E-275416013
178	1	Impeller key	Steel	E-316X316
304	1	Impeller bolt	316 SS	E-275440031
351	1	Casing o-ring	Buna	E-230X5.3B
			Viton	E-230X5.3V
370	12	Casing bolt	304 Stainless steel	E-M10X35HH
371	4	Motor bolt	Steel	E-1/2-13X1-1/2
383	1	Mechanical seal	Carbon/Ceramic/Buna	S18-2821-ABN
			Carbon/Ceramic/Viton	S18-2821-AVT
			Carbon/S.S./EPR	S18-2821-CEP
			Carbon/Carbide/Viton	S18-2821-BVT
			Carbide/Carbide/Viton	S18-2821-EVT
408	1	Casing plug	304 Stainless steel	E-363631000
412	1	Impeller gasket	Teflon	E-275476030
413	1	Sleeve gasket	Teflon	E-275476029
414	1	Sleeve gasket	Teflon	E-275476028
470	12	Casing bolt nut	304 Stainless Steel	E-M10HN



SERIES PS
Parts List
MODEL - PSF2004

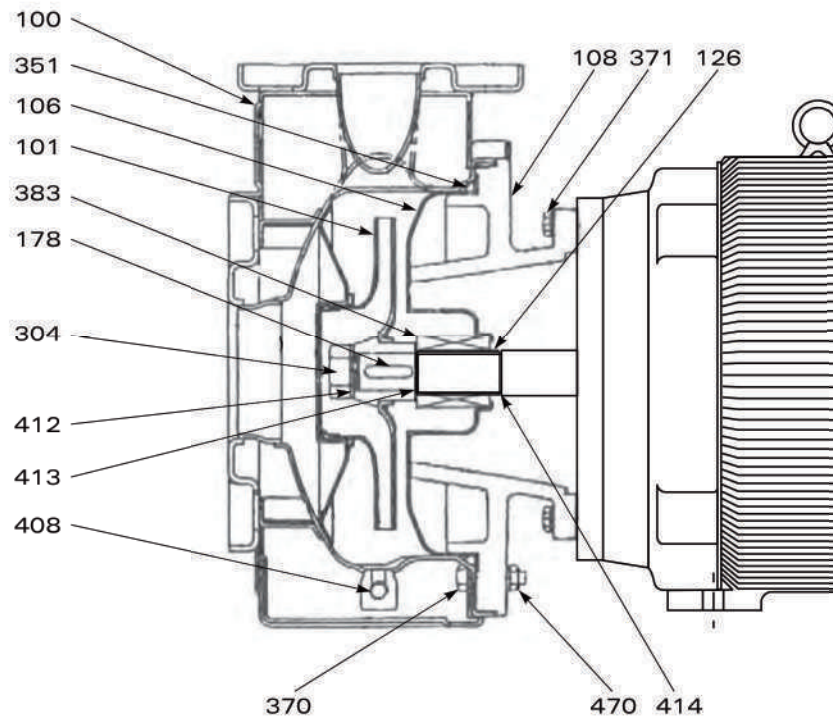

ITEM	QTY REQ'D	DESCRIPTION	MATERIAL	PART NUMBER
100	1	Casing	304 Stainless steel	E-251402208
101	1	Impeller	304 Stainless steel	E-251450880
106	1	Casing cover	304 Stainless steel	E-251402221
108	1	Adapter	C.I. (up to 184JM)	E-240080583
			C.I. (213JM and up)	E-240080584
126	1	Shaft sleeve	304 Stainless steel	E-275416013
178	1	Impeller key	Steel	E-316X316
304	1	Impeller bolt	316 SS	E-275440031
351	1	Casing o-ring	Buna	E-230X5.3B
			Viton	E-230X5.3V
370	12	Casing bolt	304 Stainless steel	E-M10X35HH
371	4	Motor bolt	Steel	E-1/2-13X1-1/2
383	1	Mechanical seal	Carbon/Ceramic/Buna	S18-2821-ABN
			Carbon/Ceramic/Viton	S18-2821-AVT
			Carbon/S.S./EPR	S18-2821-CEP
			Carbon/Carbide/Viton	S18-2821-BVT
			Carbide/Carbide/Viton	S18-2821-EVT
408	1	Casing plug	304 Stainless steel	E-363631000
412	1	Impeller gasket	Teflon	E-275476030
413	1	Sleeve gasket	Teflon	E-275476029
414	1	Sleeve gasket	Teflon	E-275476028
470	12	Casing bolt nut	304 Stainless Steel	E-M10HN



SERIES PS Parts List MODEL - PSF3001

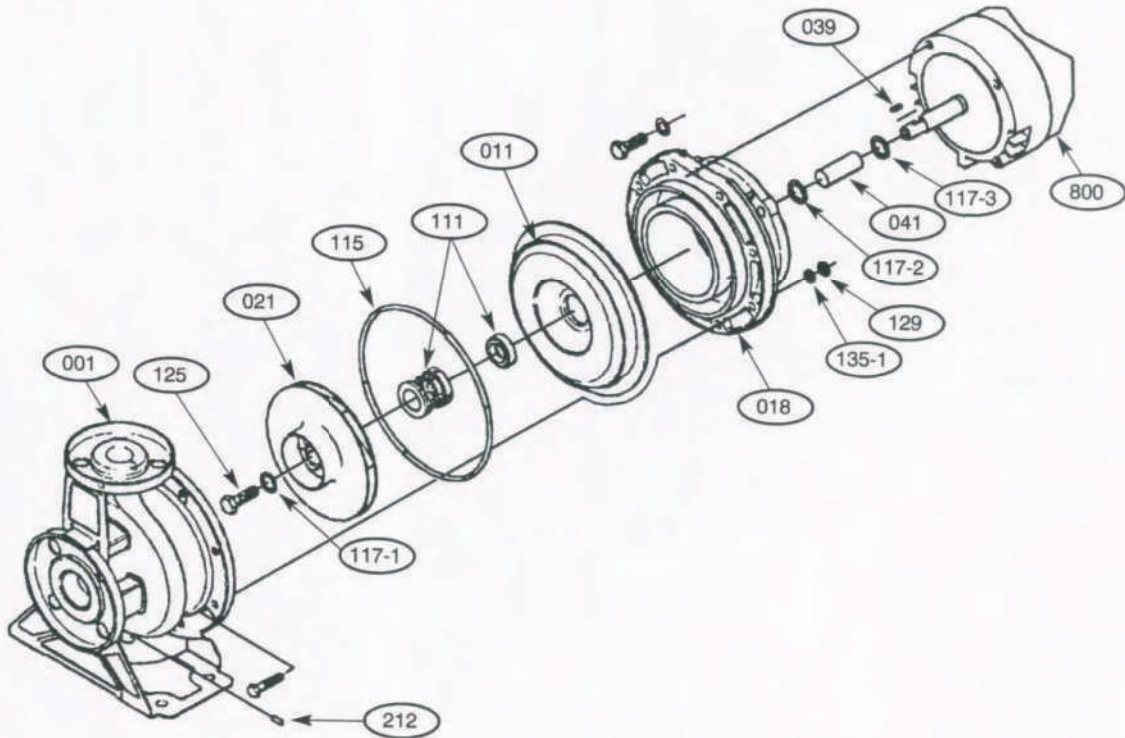

Part No.	Part Name	Material	Req'd	Part Number
001	Casing	304L Stainless	1	251421526
011	Casing cover	304L Stainless	1	251438024
018	Bracket	Cast Iron	1	240080582
021	Impeller	304L Stainless	1	240350137
039	Key	304L Stainless	1	316X1316KEY
041	Shaft sleeve	304L Stainless	1	275416013
111	Mechanical seal	Various	1	See pump price pages
115	O-Ring	Viton	1	190X5.3ORING
117-1	Gasket	Nylon	1	275476030
117-2	Gasket	Nylon	1	275476028
117-3	Gasket	Nylon	1	275476029
125	Impeller Bolt	304L Stainless	1	275440031
160	Motor support (not shown)	Steel	1 set	271472082
212	Plug	304L Stainless	1	
800	Motor	-	1	
	Suction Flange Gasket	Viton	1	364701165
	Discharge Flange Gasket	Viton	1	364701180



SERIES PS Parts List

MODEL - PSF3002

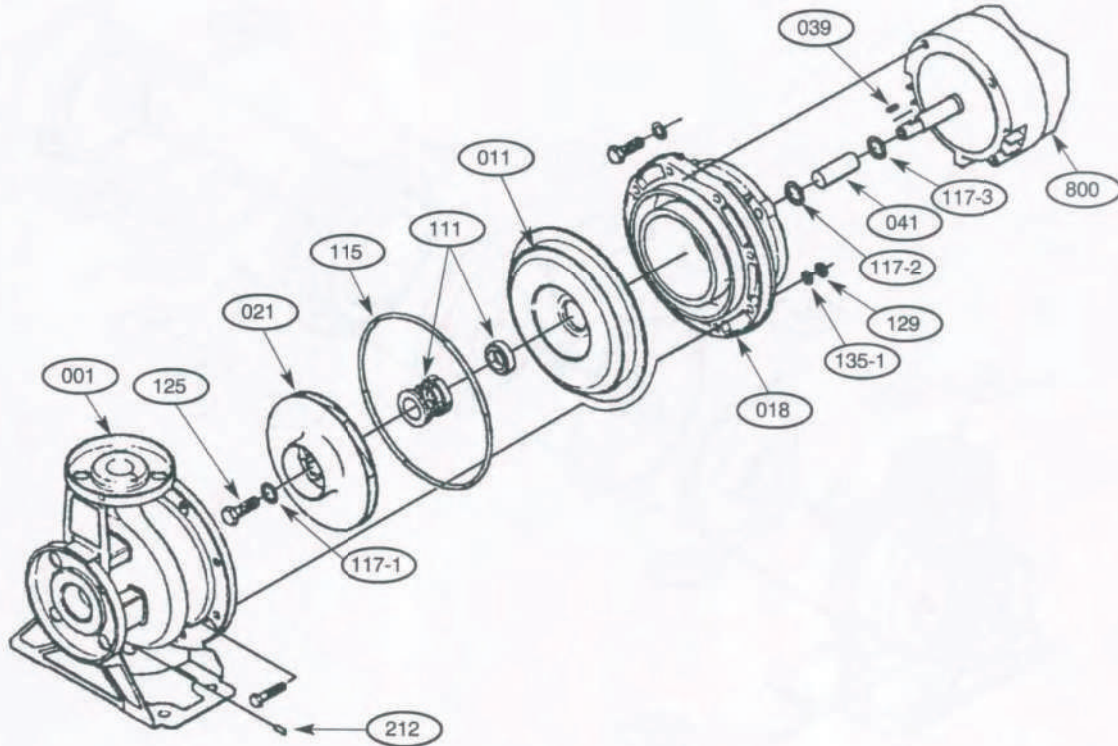

Part No.	Part Name	Material	Req'd	Part Number
001	Casing	304L Stainless	1	251421526
011	Casing cover	304L Stainless	1	251438024
018	Bracket	Cast Iron	1	240080582
021	Impeller	304L Stainless	1	240350138
039	Key	304L Stainless	1	316X1316KEY
041	Shaft sleeve	304L Stainless	1	275416013
111	Mechanical seal	Various	1	See pump price pages
115	O-Ring	Viton	1	190X5.3ORING
117-1	Gasket	Nylon	1	275476030
117-2	Gasket	Nylon	1	275476028
117-3	Gasket	Nylon	1	275476029
125	Impeller Bolt	304L Stainless	1	275440031
160	Motor support (not shown)	Steel	1 set	271472082
212	Plug	304L Stainless	1	
800	Motor	-	1	
	Suction Flange Gasket	Viton	1	364701165
	Discharge Flange Gasket	Viton	1	364701180



SERIES PS Parts List

MODEL - PSF3003

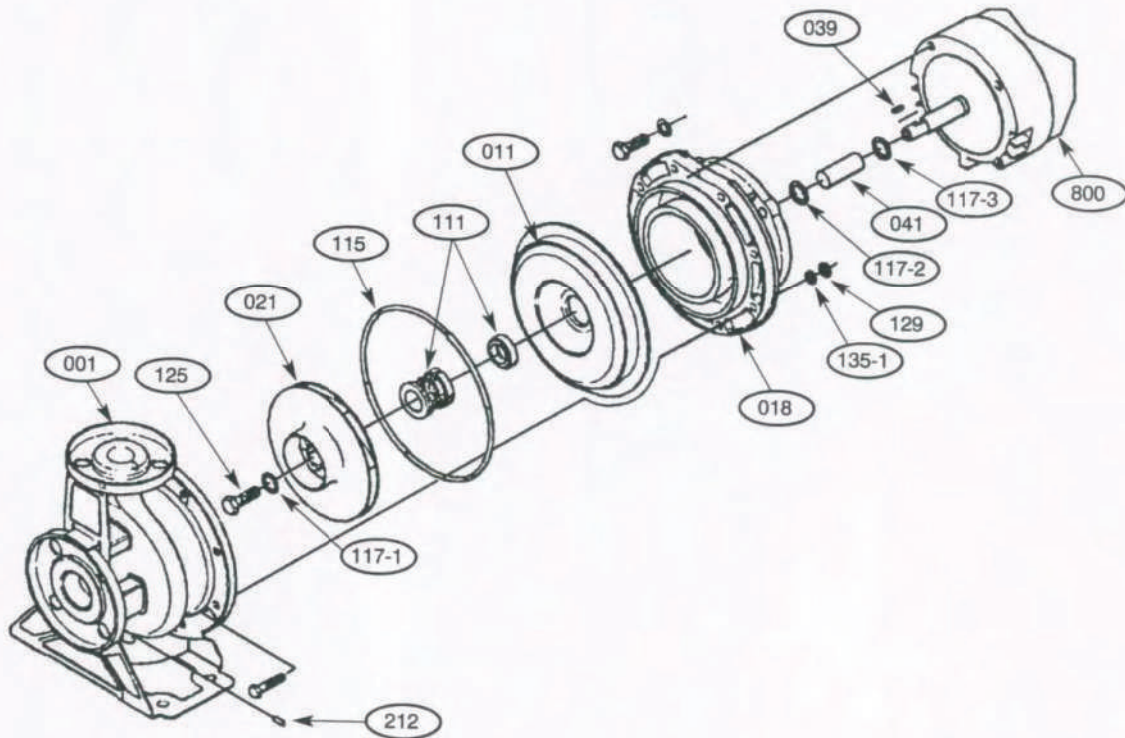

Part No.	Part Name	Material	Req'd	Part Number
001	Casing	304L Stainless	1	251421527
011	Casing cover	304L Stainless	1	251438026
018	Bracket	Cast Iron	1	240080584
021	Impeller	304L Stainless	1	240350139
039	Key	304L Stainless	1	316X1316KEY
041	Shaft sleeve	304L Stainless	1	275416013
111	Mechanical seal	Various	1	See pump price pages
115	O-Ring	Viton	1	230X5.3ORING
117-1	Gasket	Nylon	1	275476030
117-2	Gasket	Nylon	1	275476028
117-3	Gasket	Nylon	1	275476029
125	Impeller Bolt	304L Stainless	1	275440031
160	Motor support (not shown)	Steel	1 set	271472082
212	Plug	304L Stainless	1	
800	Motor	-	1	
	Suction Flange Gasket	Viton	1	364701165
	Discharge Flange Gasket	Viton	1	364701180



SERIES PS Parts List

MODEL - PSF3004

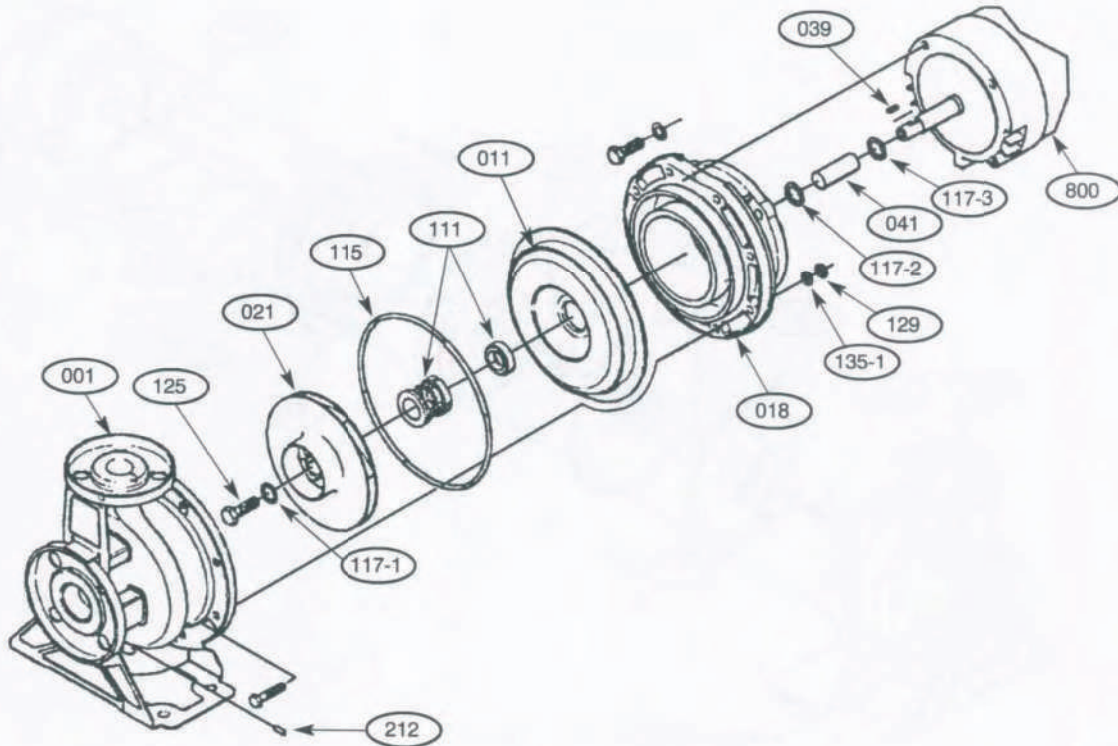

Part No.	Part Name	Material	Req'd	Part Number
001	Casing	304L Stainless	1	251421527
011	Casing cover	304L Stainless	1	251438026
018	Bracket	Cast Iron	1	240080584
021	Impeller	304L Stainless	1	240350140
039	Key	304L Stainless	1	316X1316KEY
041	Shaft sleeve	304L Stainless	1	275416013
111	Mechanical seal	Various	1	See pump price pages
115	O-Ring	Viton	1	230X5.3ORING
117-1	Gasket	Nylon	1	275476030
117-2	Gasket	Nylon	1	275476028
117-3	Gasket	Nylon	1	275476029
125	Impeller Bolt	304L Stainless	1	275440031
160	Motor support (not shown)	Steel	1 set	271472082
212	Plug	304L Stainless	1	
800	Motor	-	1	
	Suction Flange Gasket	Viton	1	364701165
	Discharge Flange Gasket	Viton	1	364701180



SERIES PS Parts List

MODEL - PSF3005

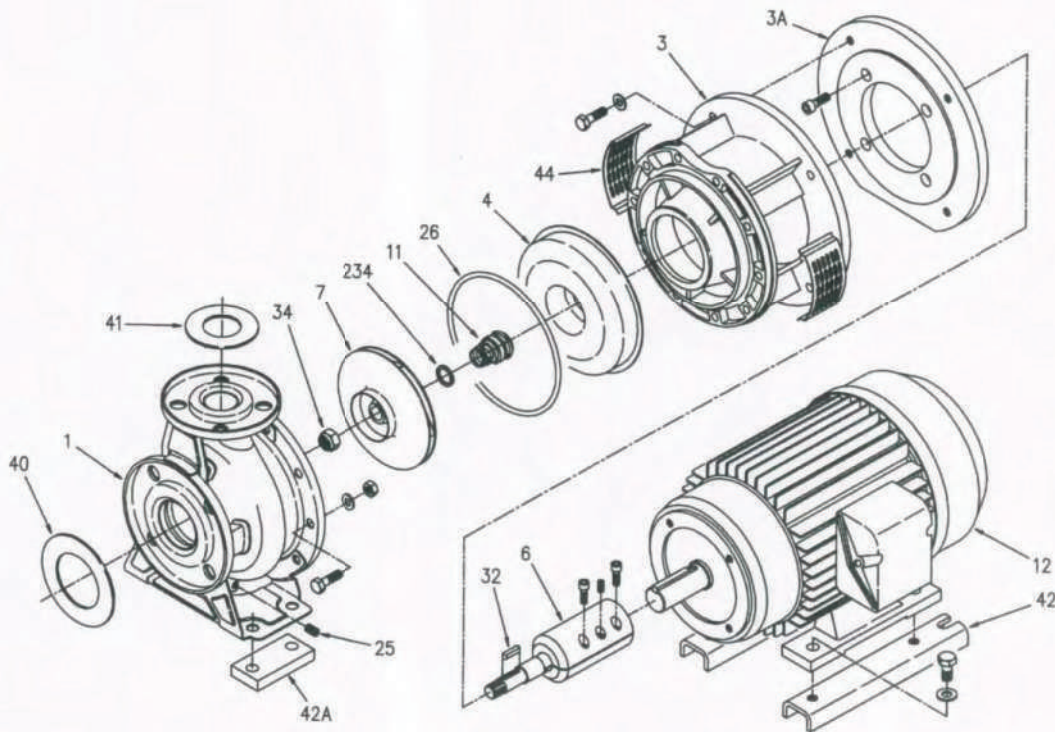

Part No.	Part Name	Material	Req'd	Part Number
001	Casing	304L Stainless	1	251421527
003	Motor Bracket	Cast Iron	1	240080603
003A	Motor Adapter	Cast Iron	1	241410133
004	Casing Cover	304L Stainless	1	251438039
006	Coupling	Steel/Stainless	1	375449005
007	Impeller	304L Stainless	1	240350141
111	Mechanical Seal	Various	1	See pump price pages
026	O-ring	Viton	1	230X5.3ORING
032	Key	304L Stainless	1	516X516KEY
034	Impeller Nut	Stainless/Nylon	1	7/8-14LOCKNUT
040	Suction Flange Gasket	EPDM	1	364701180
041	Discharge Flange Gasket	EPDM	1	364701165
042	Motor Support	Steel	2	271472167
044	Coupling Guard	Stainless	2	271473017
234	Lip Seal	304L Stainless	1	275476039



SERIES PS Parts List

MODEL - PSF3006

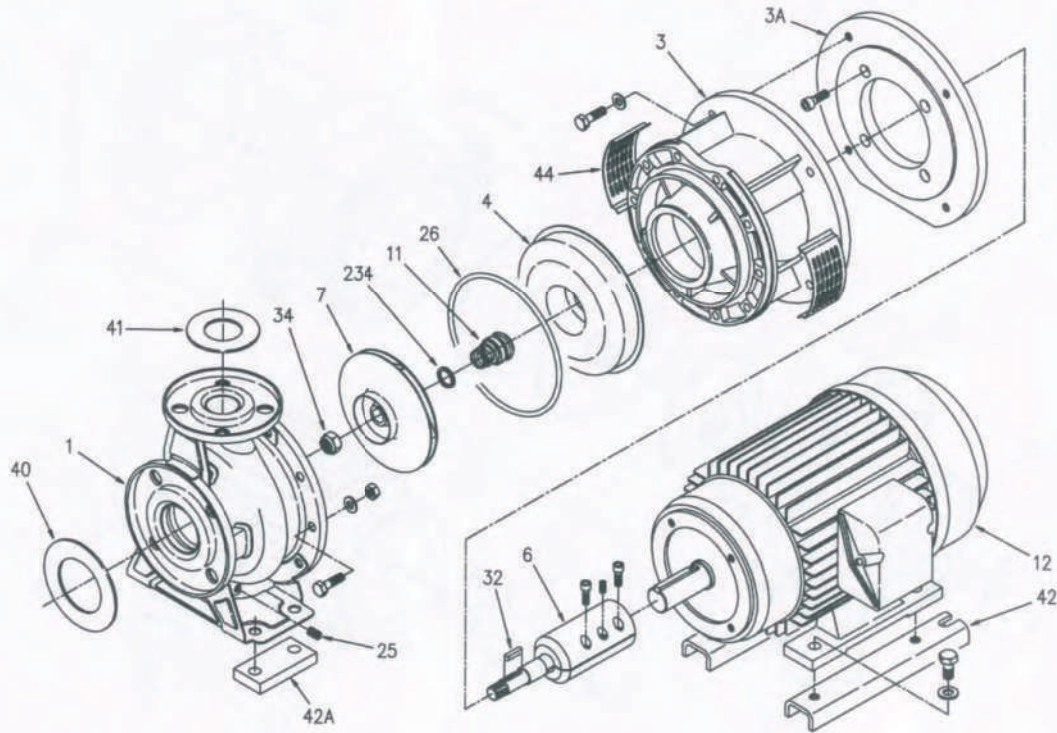

Part No.	Part Name	Material	Req'd	Part Number
001	Casing	304L Stainless	1	251421527
003	Motor Bracket	Cast Iron	1	240080603
003A	Motor Adapter	Cast Iron	1	241410134
004	Casing Cover	304L Stainless	1	251438039
006	Coupling	Steel/Stainless	1	375449005
007	Impeller	304L Stainless	1	240350142
111	Mechanical Seal	Various	1	See pump price pages
026	O-ring	Viton	1	230X5.3ORING
032	Key	304L Stainless	1	516X516KEY
034	Impeller Nut	Stainless/Nylon	1	7/8-14LOCKNUT
040	Suction Flange Gasket	EPDM	1	364701180
041	Discharge Flange Gasket	EPDM	1	364701165
042A	Casing Support	Steel	2	271472170
044	Coupling Guard	Stainless	2	271473017
234	Lip Seal	304L Stainless	1	275476039



SERIES PS Parts List MODEL - PSF3007

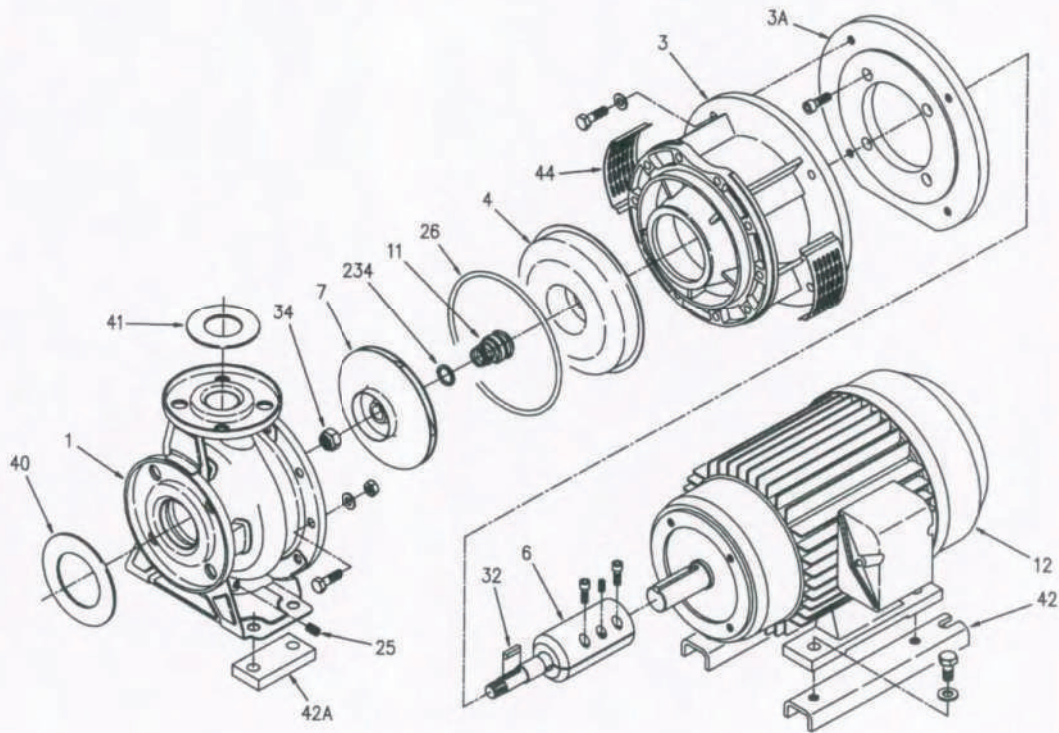

Part No.	Part Name	Material	Req'd	Part Number
001	Casing	304L Stainless	1	251421528
003	Motor Bracket	Cast Iron	1	240080603
003A	Motor Adapter	Cast Iron	1	241410133
004	Casing Cover	304L Stainless	1	251438039
006	Coupling	Steel/Stainless	1	375449005
007	Impeller	304L Stainless	1	240350143
111	Mechanical Seal	Various	1	See pump price pages
026	O-ring	Viton	1	230X5.3ORING
032	Key	304L Stainless	1	516X516KEY
034	Impeller Nut	Stainless/Nylon	1	7/8-14LOCKNUT
040	Suction Flange Gasket	EPDM	1	364701180
041	Discharge Flange Gasket	EPDM	1	364701165
042	Motor Support	Steel	2	271472169
044	Coupling Guard	Stainless	2	271473017
234	Lip Seal	304L Stainless	1	275476039



SERIES PS Parts List

MODEL - PSF3008

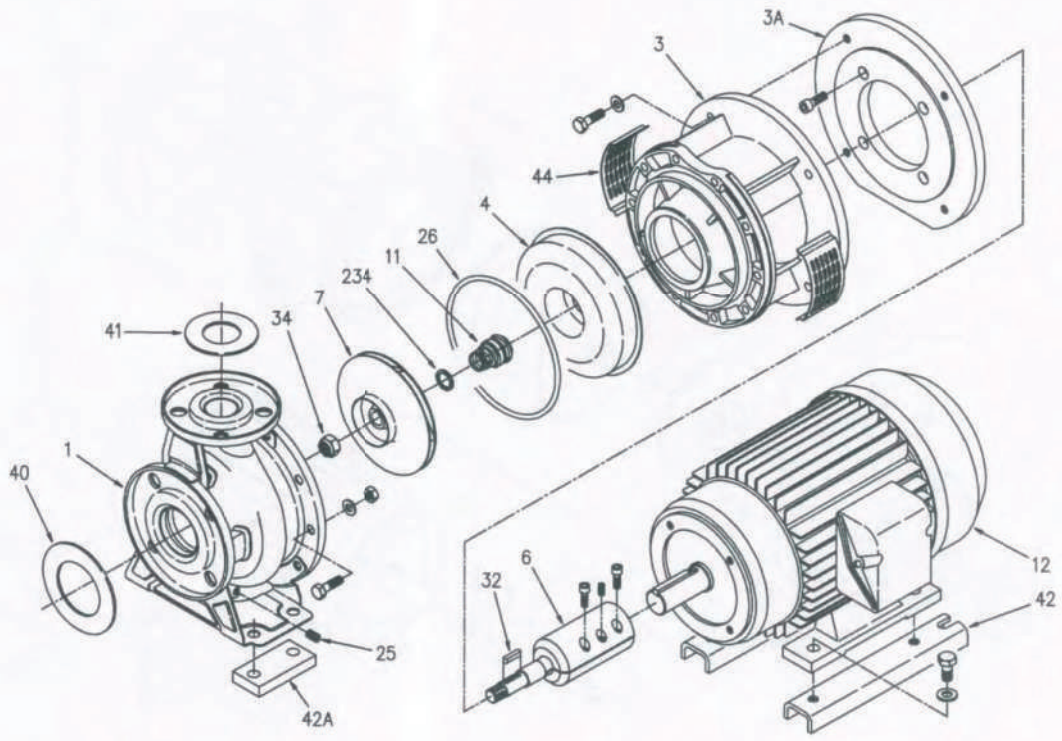

Part No.	Part Name	Material	Req'd	Part Number
001	Casing	304L Stainless	1	251421528
003	Motor Bracket	Cast Iron	1	240080603
003A	Motor Adapter	Cast Iron	1	241410134
004	Casing Cover	304L Stainless	1	251438039
006	Coupling	Steel/Stainless	1	375449005
007	Impeller	304L Stainless	1	240350144
111	Mechanical Seal	Various	1	See pump price pages
026	O-ring	Viton	1	230X5.3ORING
032	Key	304L Stainless	1	516X516KEY
034	Impeller Nut	Stainless/Nylon	1	7/8-14LOCKNUT
040	Suction Flange Gasket	EPDM	1	364701180
041	Discharge Flange Gasket	EPDM	1	364701165
042	Motor Support	Steel	2	271472168
044	Coupling Guard	Stainless	2	271473017
234	Lip Seal	304L Stainless	1	275476039



SERIES PS Parts List MODEL - PSF3009

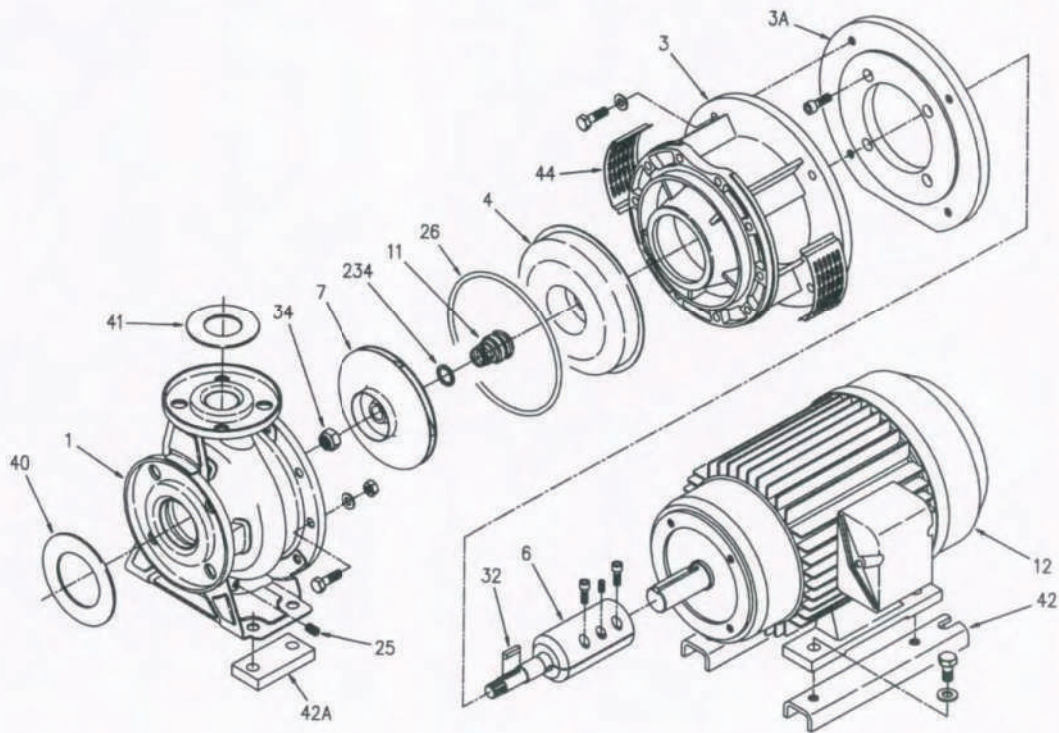

Part No.	Part Name	Material	Req'd	Part Number
001	Casing	304L Stainless	1	251421528
003	Motor Bracket	Cast Iron	1	240080603
003A	Motor Adapter	Cast Iron	1	241410134
004	Casing Cover	304L Stainless	1	251438039
006	Coupling	Steel/Stainless	1	375449005
007	Impeller	304L Stainless	1	240350145
111	Mechanical Seal	Various	1	See pump price pages
026	O-ring	Viton	1	230X5.3ORING
032	Key	304L Stainless	1	516X516KEY
034	Impeller Nut	Stainless/Nylon	1	7/8-14LOCKNUT
040	Suction Flange Gasket	EPDM	1	364701180
041	Discharge Flange Gasket	EPDM	1	364701165
042	Motor Support	Steel	2	271472168
044	Coupling Guard	Stainless	2	271473017
234	Lip Seal	304L Stainless	1	275476039



SERIES PS - DIMENSIONAL OUTLINE
MODEL - PSF701

CUSTOMER - _____
 CUSTOMER REF. - _____ OUR REF. - _____
 HP - _____ RPM - _____ VOLTAGE - _____ ENCL. - _____

CERTIFIED - _____ DATE - _____

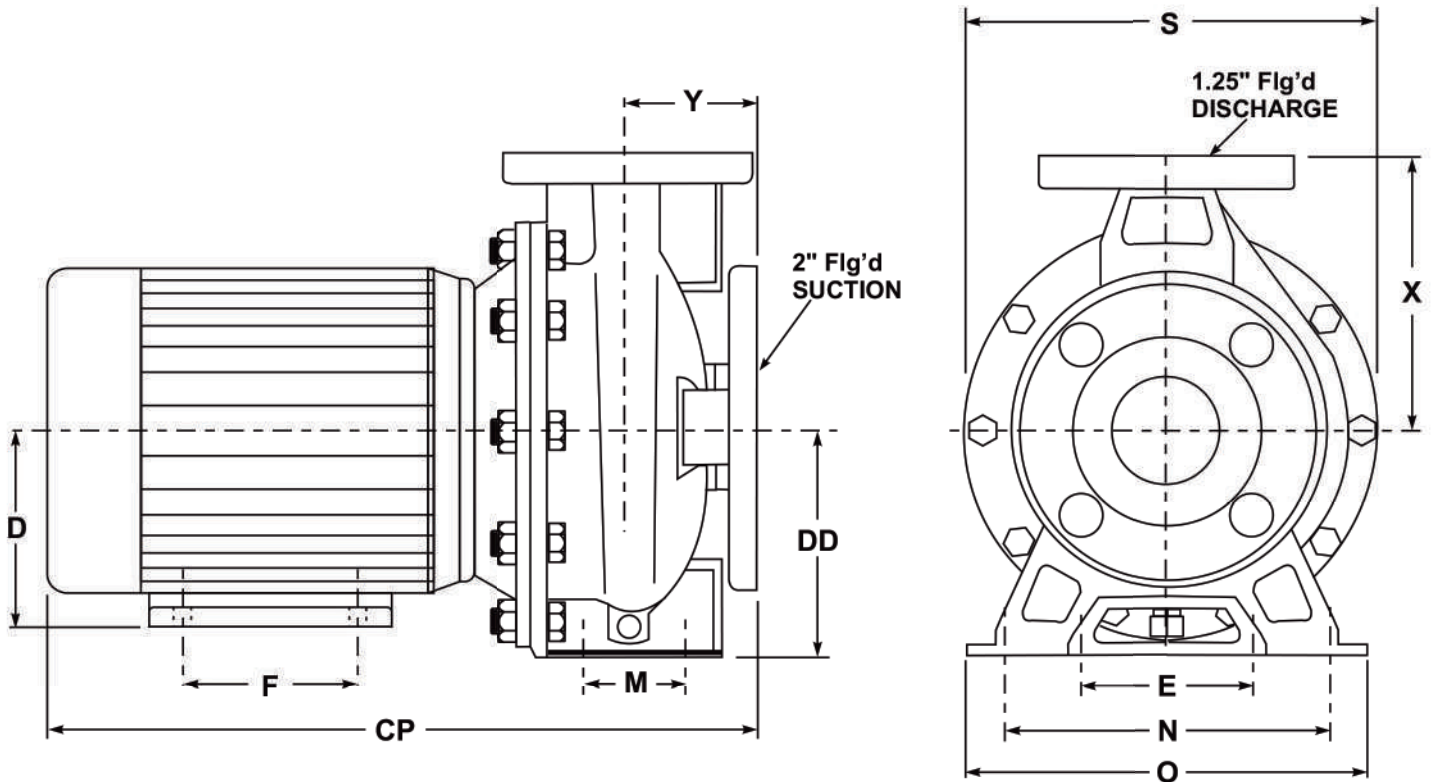

MOTOR FRAME	DIMENSIONS											WEIGHT (lbs)	
	CP*	F	E**	D	DD	M	N	O	S	X	Y	PUMP	MOTOR
143JM	16.75	4.0	5.5	3.50	4.44	2.75	5.5	7.5	8.38	5.5	3.12	20	44
145JM	17.75	5.0	5.5	3.50	4.44	2.75	5.5	7.5	8.38	5.5	3.12	20	44
182JM	18.50	4.5	7.5	4.50	4.44	2.75	5.5	7.5	8.38	5.5	3.12	20	90
184JM	19.50	5.5	7.5	4.50	4.44	2.75	5.5	7.5	8.38	5.5	3.12	20	110
213JM	21.25	5.5	8.5	5.25	4.44	2.75	5.5	7.5	8.38	5.5	3.12	20	120
215JM	22.75	7.0	8.5	5.25	4.44	2.75	5.5	7.5	8.38	5.5	3.12	20	160

NOTES - Not for construction purposes unless certified above.
 - All dimensions in inches.
 - Some dimensions may vary +/- 0.25 inches.
 - * Approximate only.
 - ** Motor mount hole spacing.



SERIES PS - DIMENSIONAL OUTLINE

MODEL - PSF702

CUSTOMER - _____
 CUSTOMER REF. - _____ OUR REF. - _____
 HP - _____ RPM - _____ VOLTAGE - _____ ENCL. - _____

CERTIFIED - _____ DATE - _____

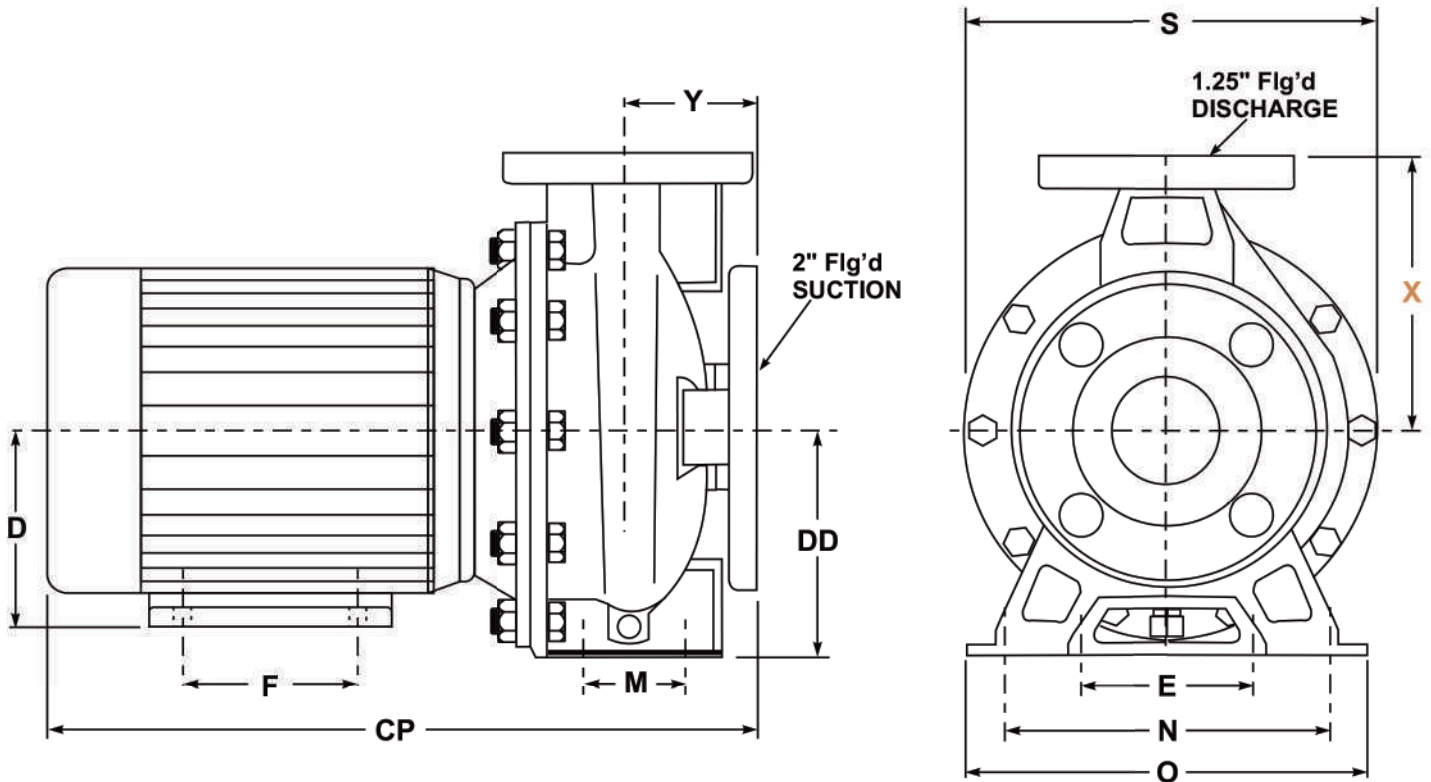

MOTOR FRAME	DIMENSIONS											WEIGHT (lbs)	
	CP*	F	E**	D	DD	M	N	O	S	X	Y	PUMP	MOTOR
143JM	16.75	4.0	5.5	3.50	5.19	2.75	7.5	9.44	10	6.31	3.12	20	44
145JM	17.75	5.0	5.5	3.50	5.19	2.75	7.5	9.44	10	6.31	3.12	20	44
182JM	18.50	4.5	7.5	4.50	5.19	2.75	7.5	9.44	10	6.31	3.12	20	90
184JM	19.50	5.5	7.5	4.50	5.19	2.75	7.5	9.44	10	6.31	3.12	20	110
213JM	21.25	5.5	8.5	5.25	5.19	2.75	7.5	9.44	10	6.31	3.12	20	120
215JM	22.75	7.0	8.5	5.25	5.19	2.75	7.5	9.44	10	6.31	3.12	20	160

NOTES - Not for construction purposes unless certified above.
 - All dimensions in inches.
 - Some dimensions may vary +/- 0.25 inches.
 - * Approximate only.
 - ** Motor mount hole spacing.



SERIES PS - DIMENSIONAL OUTLINE
MODEL - PSF703

CUSTOMER - _____
 CUSTOMER REF. - _____ OUR REF. - _____
 HP - _____ RPM - _____ VOLTAGE - _____ ENCL. - _____

CERTIFIED - _____ DATE - _____

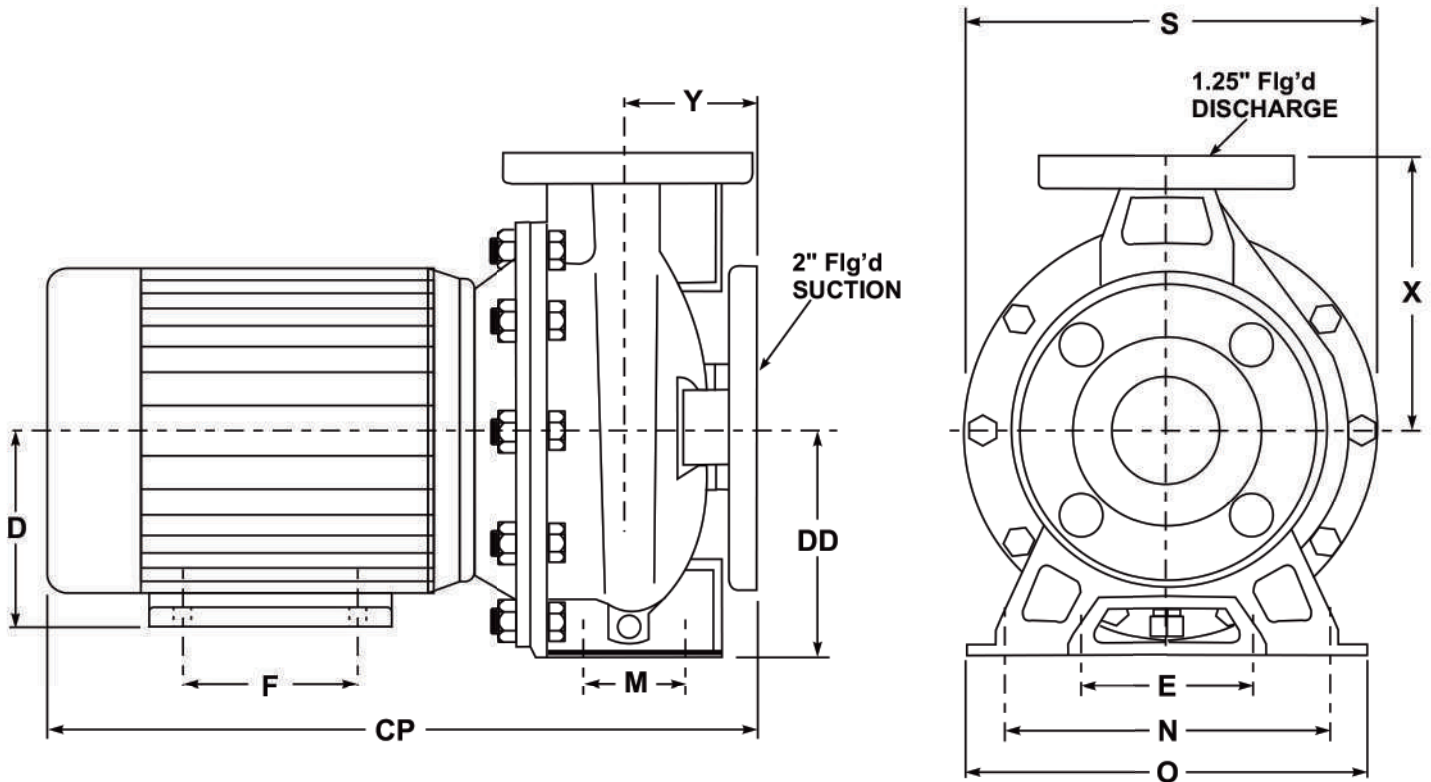

MOTOR FRAME	DIMENSIONS											WEIGHT (lbs)	
	CP*	F	E**	D	DD	M	N	O	S	X	Y	PUMP	MOTOR
143JM	16.75	4.0	5.5	3.50	5.19	2.75	7.5	9.44	10	6.31	3.12	20	44
145JM	17.75	5.0	5.5	3.50	5.19	2.75	7.5	9.44	10	6.31	3.12	20	44
182JM	18.50	4.5	7.5	4.50	5.19	2.75	7.5	9.44	10	6.31	3.12	20	90
184JM	19.50	5.5	7.5	4.50	5.19	2.75	7.5	9.44	10	6.31	3.12	20	110
213JM	21.25	5.5	8.5	5.25	5.19	2.75	7.5	9.44	10	6.31	3.12	20	120
215JM	22.75	7.0	8.5	5.25	5.19	2.75	7.5	9.44	10	6.31	3.12	20	160

NOTES - Not for construction purposes unless certified above.
 - All dimensions in inches.
 - Some dimensions may vary +/- 0.25 inches.
 - * Approximate only.
 - ** Motor mount hole spacing.



SERIES PS - DIMENSIONAL OUTLINE

MODEL - PSF704

CUSTOMER - _____
 CUSTOMER REF. - _____ OUR REF. - _____
 HP - _____ RPM - _____ VOLTAGE - _____ ENCL. - _____

CERTIFIED - _____ DATE - _____

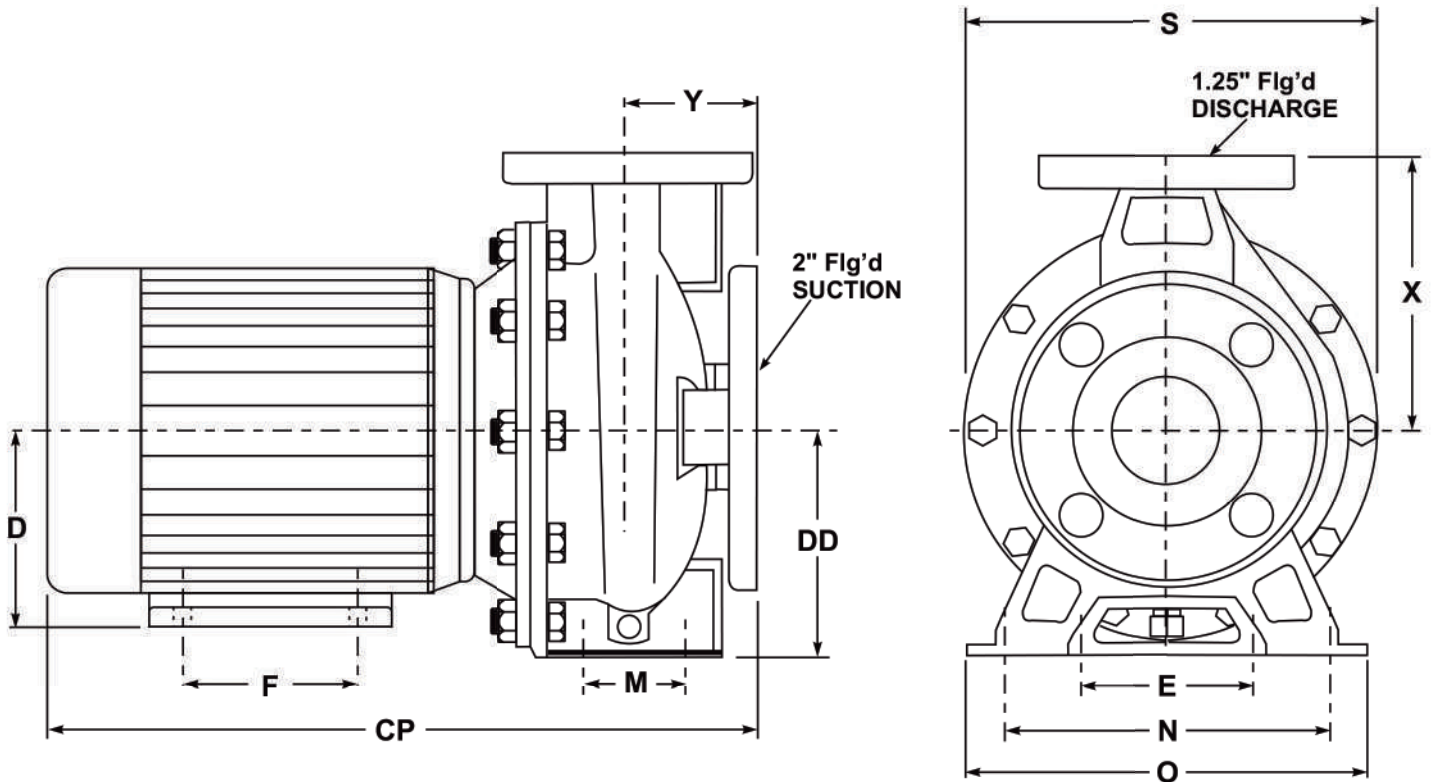

MOTOR FRAME	DIMENSIONS											WEIGHT (lbs)	
	CP*	F	E**	D	DD	M	N	O	S	X	Y	PUMP	MOTOR
143JM	19.00	4.0	5.5	3.50	6.31	2.75	7.5	9.44	11.56	7.06	3.12	20	44
145JM	20.00	5.0	5.5	3.50	6.31	2.75	7.5	9.44	11.56	7.06	3.12	20	44
182JM	21.75	4.5	7.5	4.50	6.31	2.75	7.5	9.44	11.56	7.06	3.12	20	90
184JM	22.75	5.5	7.5	4.50	6.31	2.75	7.5	9.44	11.56	7.06	3.12	20	110
213JM	24.50	5.5	8.5	5.25	6.31	2.75	7.5	9.44	11.56	7.06	3.12	20	120
215JM	26.00	7.0	8.5	5.25	6.31	2.75	7.5	9.44	11.56	7.06	3.12	20	160

NOTES - Not for construction purposes unless certified above.
 - All dimensions in inches.
 - Some dimensions may vary +/- 0.25 inches.
 - * Approximate only.
 - ** Motor mount hole spacing.



SERIES PS - DIMENSIONAL OUTLINE
MODEL - PSF705

CUSTOMER - _____
 CUSTOMER REF. - _____ OUR REF. - _____
 HP - _____ RPM - _____ VOLTAGE - _____ ENCL. - _____

CERTIFIED - _____ DATE - _____

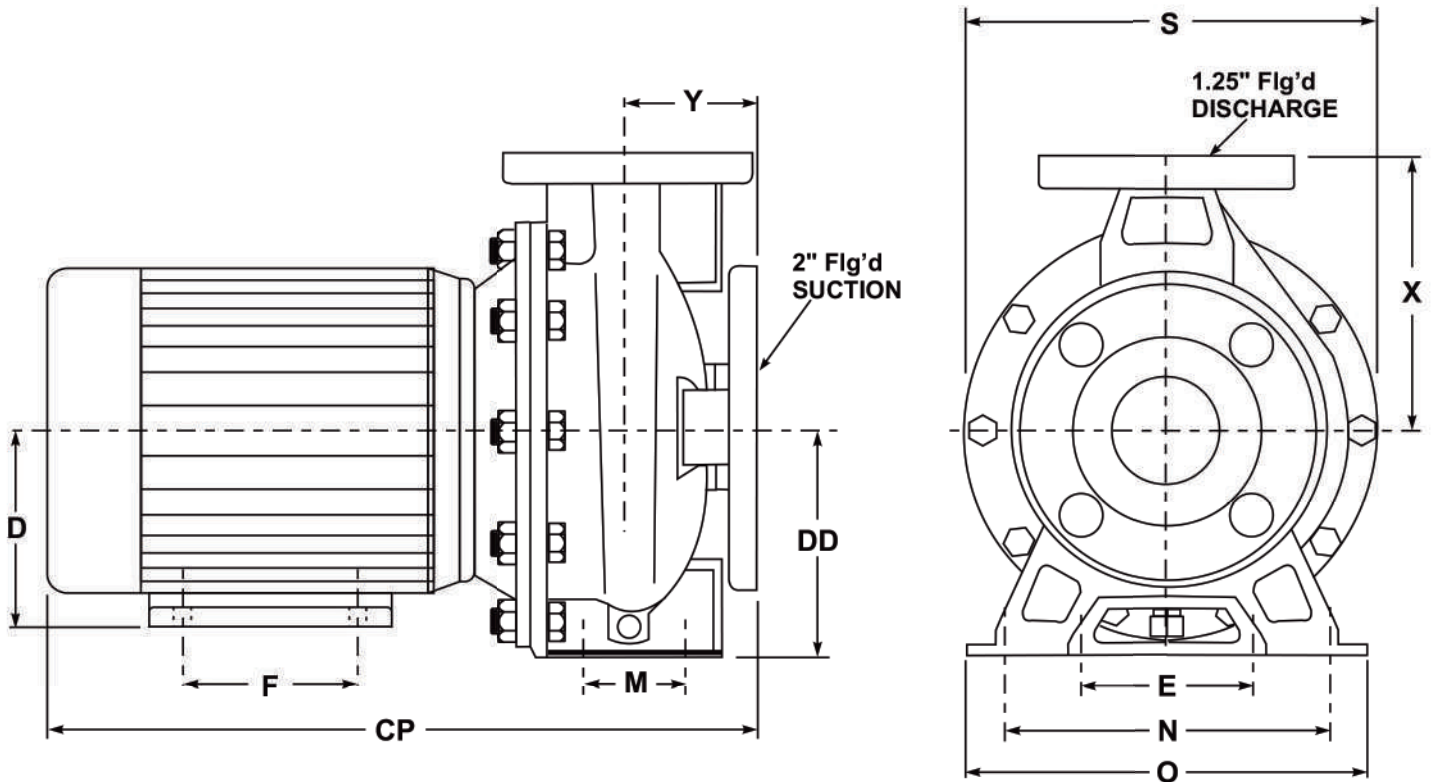

MOTOR FRAME	DIMENSIONS											WEIGHT (lbs)	
	CP*	F	E**	D	DD	M	N	O	S	X	Y	PUMP	MOTOR
143JM	19.00	4.0	5.5	3.50	6.31	2.75	7.5	9.44	11.56	7.06	3.12	20	44
145JM	20.00	5.0	5.5	3.50	6.31	2.75	7.5	9.44	11.56	7.06	3.12	20	44
182JM	21.75	4.5	7.5	4.50	6.31	2.75	7.5	9.44	11.56	7.06	3.12	20	90
184JM	22.75	5.5	7.5	4.50	6.31	2.75	7.5	9.44	11.56	7.06	3.12	20	110
213JM	24.50	5.5	8.5	5.25	6.31	2.75	7.5	9.44	11.56	7.06	3.12	20	120
215JM	26.00	7.0	8.5	5.25	6.31	2.75	7.5	9.44	11.56	7.06	3.12	20	160

NOTES - Not for construction purposes unless certified above.
 - All dimensions in inches.
 - Some dimensions may vary +/- 0.25 inches.
 - * Approximate only.
 - ** Motor mount hole spacing.



SERIES PS - DIMENSIONAL OUTLINE
MODEL - PSF1201

CUSTOMER - _____
 CUSTOMER REF. - _____ OUR REF. - _____
 HP - _____ RPM - _____ VOLTAGE - _____ ENCL. - _____

CERTIFIED - _____ DATE - _____

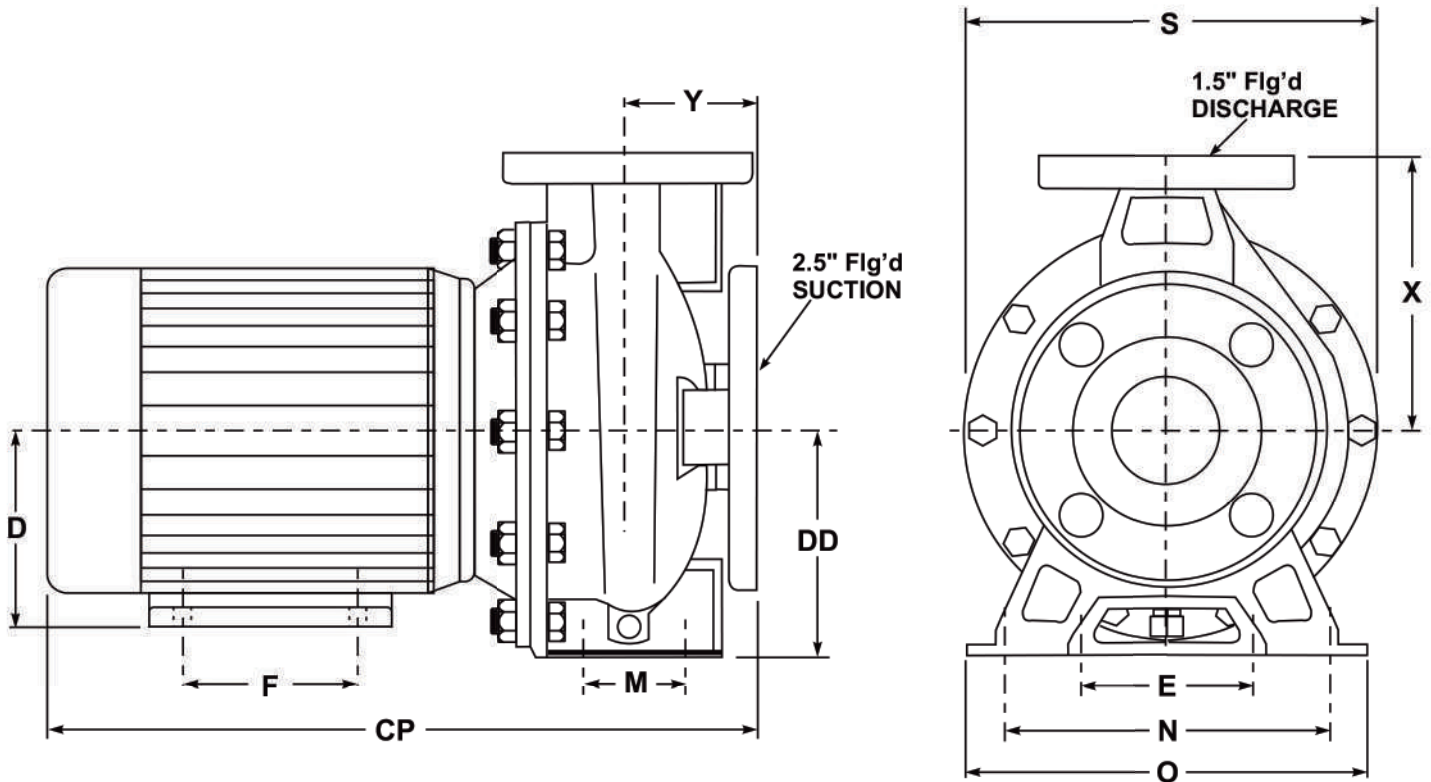

MOTOR FRAME	DIMENSIONS											WEIGHT (lbs)	
	CP*	F	E**	D	DD	M	N	O	S	X	Y	PUMP	MOTOR
143JM	16.75	4.0	5.5	3.50	4.44	2.75	6.31	8.25	8.75	5.5	3.12	21	44
145JM	17.75	5.0	5.5	3.50	4.44	2.75	6.31	8.25	8.75	5.5	3.12	21	44
182JM	18.50	4.5	7.5	4.50	4.44	2.75	6.31	8.25	8.75	5.5	3.12	21	90
184JM	19.50	5.5	7.5	4.50	4.44	2.75	6.31	8.25	8.75	5.5	3.12	21	110
213JM	21.25	5.5	8.5	5.25	4.44	2.75	6.31	8.25	8.75	5.5	3.12	21	120
215JM	22.75	7.0	8.5	5.25	4.44	2.75	6.31	8.25	8.75	5.5	3.12	21	160

NOTES - Not for construction purposes unless certified above.
 - All dimensions in inches.
 - Some dimensions may vary +/- 0.25 inches.
 - * Approximate only.
 - ** Motor mount hole spacing.



SERIES PS - DIMENSIONAL OUTLINE
MODEL - PSF1202

CUSTOMER - _____
 CUSTOMER REF. - _____ OUR REF. - _____
 HP - _____ RPM - _____ VOLTAGE - _____ ENCL. - _____

CERTIFIED - _____ DATE - _____

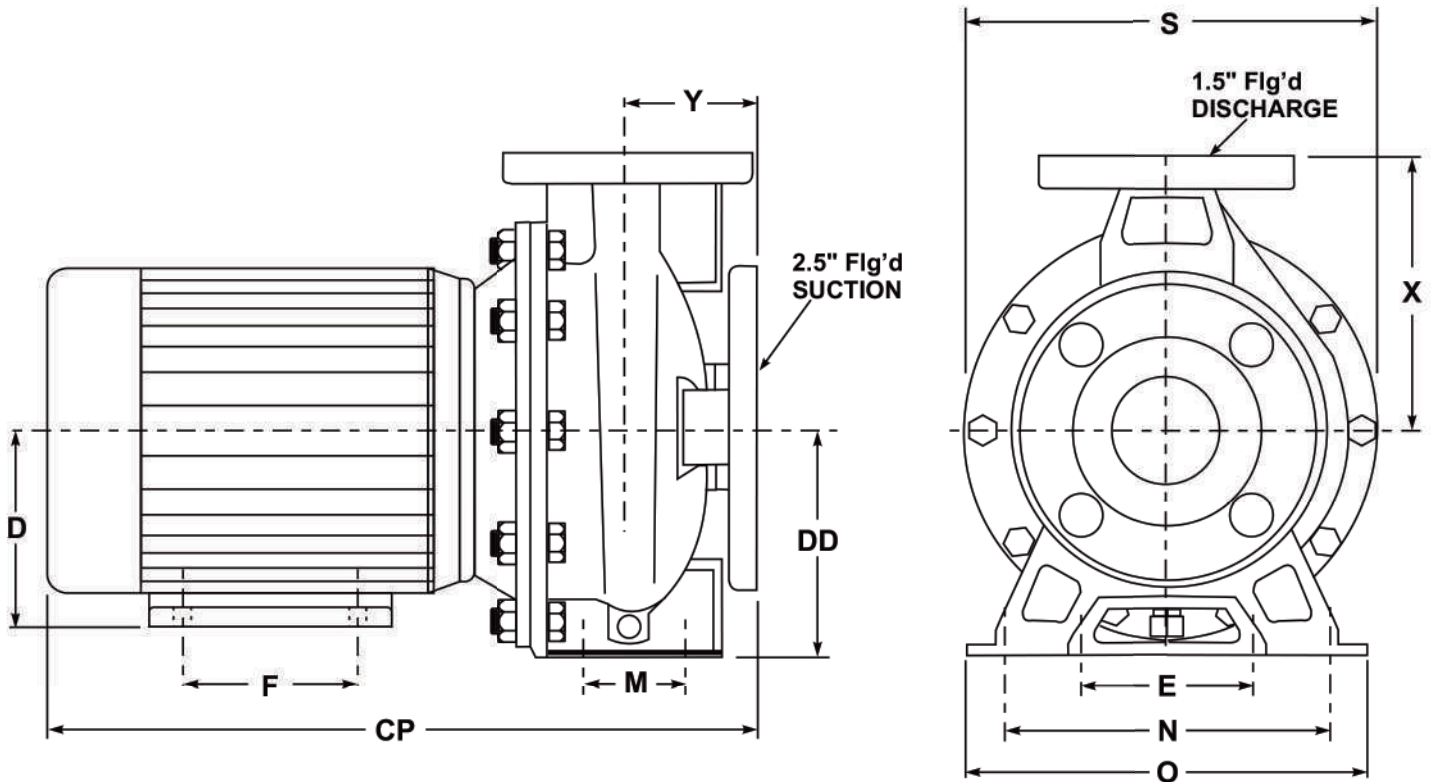

MOTOR FRAME	DIMENSIONS											WEIGHT (lbs)	
	CP*	F	E**	D	DD	M	N	O	S	X	Y	PUMP	MOTOR
143JM	16.75	4.0	5.5	3.50	4.44	2.75	6.31	8.25	8.75	5.5	3.12	21	44
145JM	17.75	5.0	5.5	3.50	4.44	2.75	6.31	8.25	8.75	5.5	3.12	21	44
182JM	18.50	4.5	7.5	4.50	4.44	2.75	6.31	8.25	8.75	5.5	3.12	21	90
184JM	19.50	5.5	7.5	4.50	4.44	2.75	6.31	8.25	8.75	5.5	3.12	21	110
213JM	21.25	5.5	8.5	5.25	4.44	2.75	6.31	8.25	8.75	5.5	3.12	21	120
215JM	22.75	7.0	8.5	5.25	4.44	2.75	6.31	8.25	8.75	5.5	3.12	21	160

NOTES - Not for construction purposes unless certified above.
 - All dimensions in inches.
 - Some dimensions may vary +/- 0.25 inches.
 - * Approximate only.
 - ** Motor mount hole spacing.



SERIES PS - DIMENSIONAL OUTLINE
MODEL - PSF1203

CUSTOMER - _____
 CUSTOMER REF. - _____ OUR REF. - _____
 HP - _____ RPM - _____ VOLTAGE - _____ ENCL. - _____

CERTIFIED - _____ DATE - _____

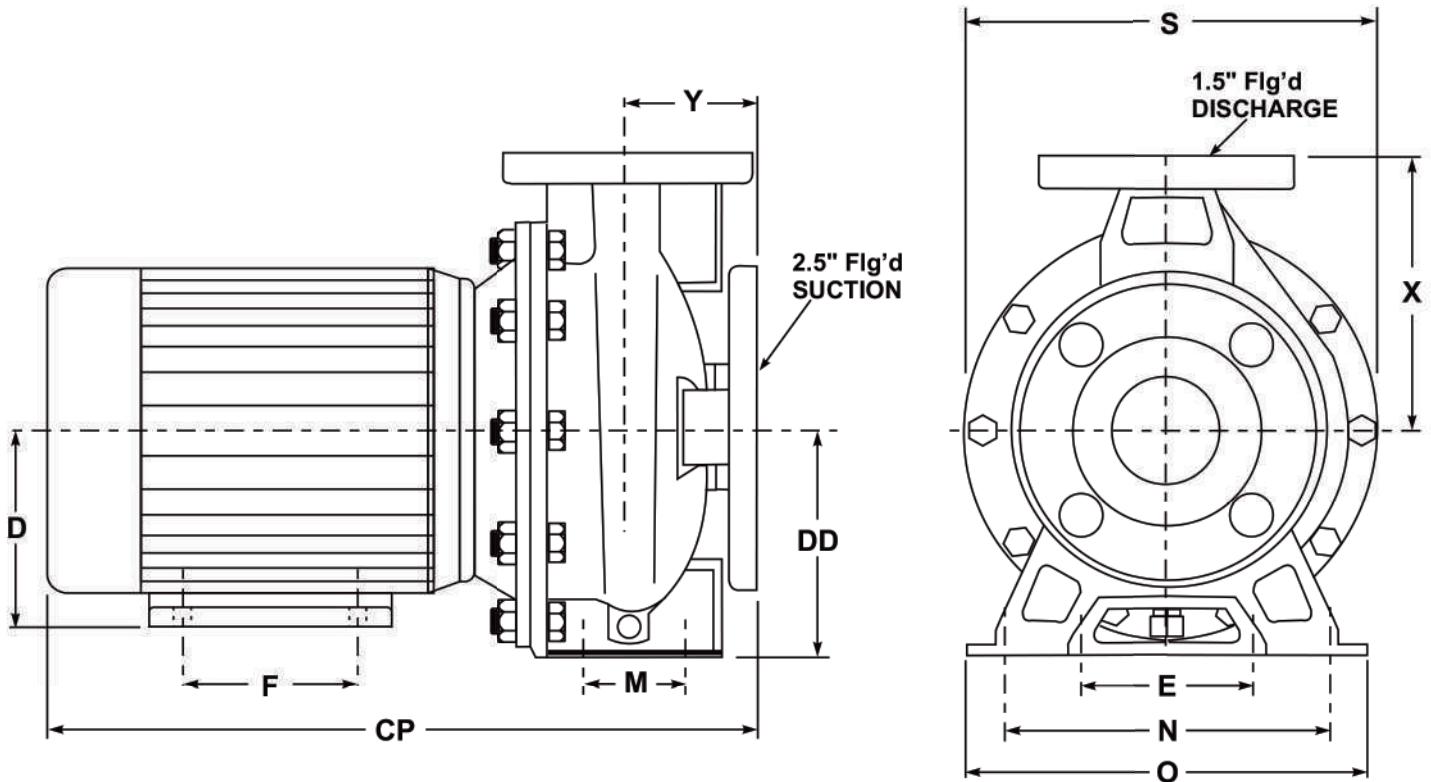

MOTOR FRAME	DIMENSIONS											WEIGHT (lbs)	
	CP*	F	E**	D	DD	M	N	O	S	X	Y	PUMP	MOTOR
143JM	16.75	4.0	5.5	3.50	5.19	2.75	7.5	9.44	10	6.31	3.12	21	44
145JM	17.75	5.0	5.5	3.50	5.19	2.75	7.5	9.44	10	6.31	3.12	21	44
182JM	18.50	4.5	7.5	4.50	5.19	2.75	7.5	9.44	10	6.31	3.12	21	90
184JM	19.50	5.5	7.5	4.50	5.19	2.75	7.5	9.44	10	6.31	3.12	21	110
213JM	21.25	5.5	8.5	5.25	5.19	2.75	7.5	9.44	10	6.31	3.12	21	120
215JM	22.75	7.0	8.5	5.25	5.19	2.75	7.5	9.44	10	6.31	3.12	21	160

NOTES - Not for construction purposes unless certified above.
 - All dimensions in inches.
 - Some dimensions may vary +/- 0.25 inches.
 - * Approximate only.
 - ** Motor mount hole spacing.



SERIES PS - DIMENSIONAL OUTLINE

MODEL - PSF1204

CUSTOMER - _____
 CUSTOMER REF. - _____ OUR REF. - _____
 HP - _____ RPM - _____ VOLTAGE - _____ ENCL. - _____

CERTIFIED - _____ DATE - _____

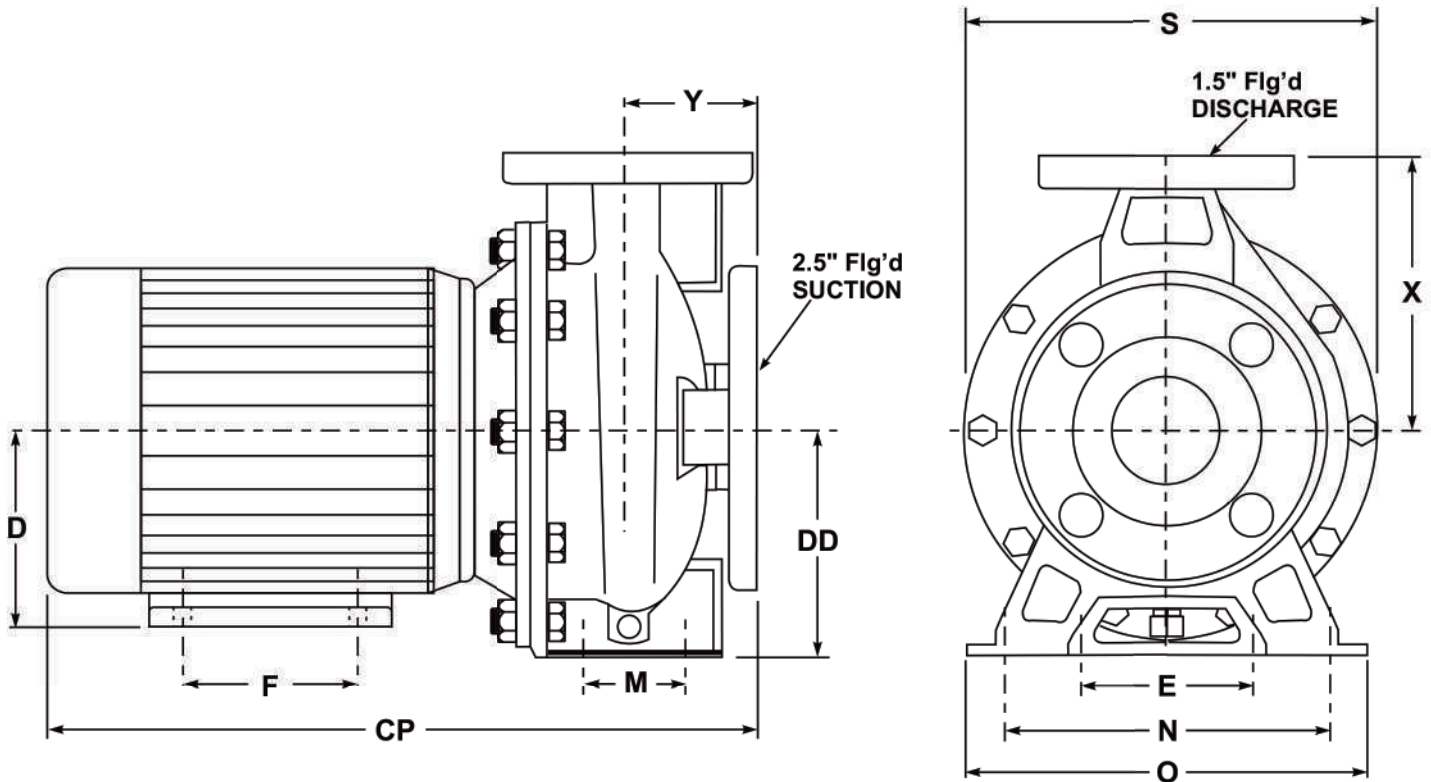

MOTOR FRAME	DIMENSIONS											WEIGHT (lbs)	
	CP*	F	E**	D	DD	M	N	O	S	X	Y	PUMP	MOTOR
143JM	16.75	4.0	5.5	3.50	5.19	2.75	7.5	9.44	10	6.31	3.12	21	44
145JM	17.75	5.0	5.5	3.50	5.19	2.75	7.5	9.44	10	6.31	3.12	21	44
182JM	18.50	4.5	7.5	4.50	5.19	2.75	7.5	9.44	10	6.31	3.12	21	90
184JM	19.50	5.5	7.5	4.50	5.19	2.75	7.5	9.44	10	6.31	3.12	21	110
213JM	21.25	5.5	8.5	5.25	5.19	2.75	7.5	9.44	10	6.31	3.12	21	120
215JM	22.75	7.0	8.5	5.25	5.19	2.75	7.5	9.44	10	6.31	3.12	21	160

NOTES - Not for construction purposes unless certified above.
 - All dimensions in inches.
 - Some dimensions may vary +/- 0.25 inches.
 - * Approximate only.
 - ** Motor mount hole spacing.



SERIES PS - DIMENSIONAL OUTLINE

MODEL - PSF1205

CUSTOMER - _____
 CUSTOMER REF. - _____ OUR REF. - _____
 HP - _____ RPM - _____ VOLTAGE - _____ ENCL. - _____

CERTIFIED - _____ DATE - _____

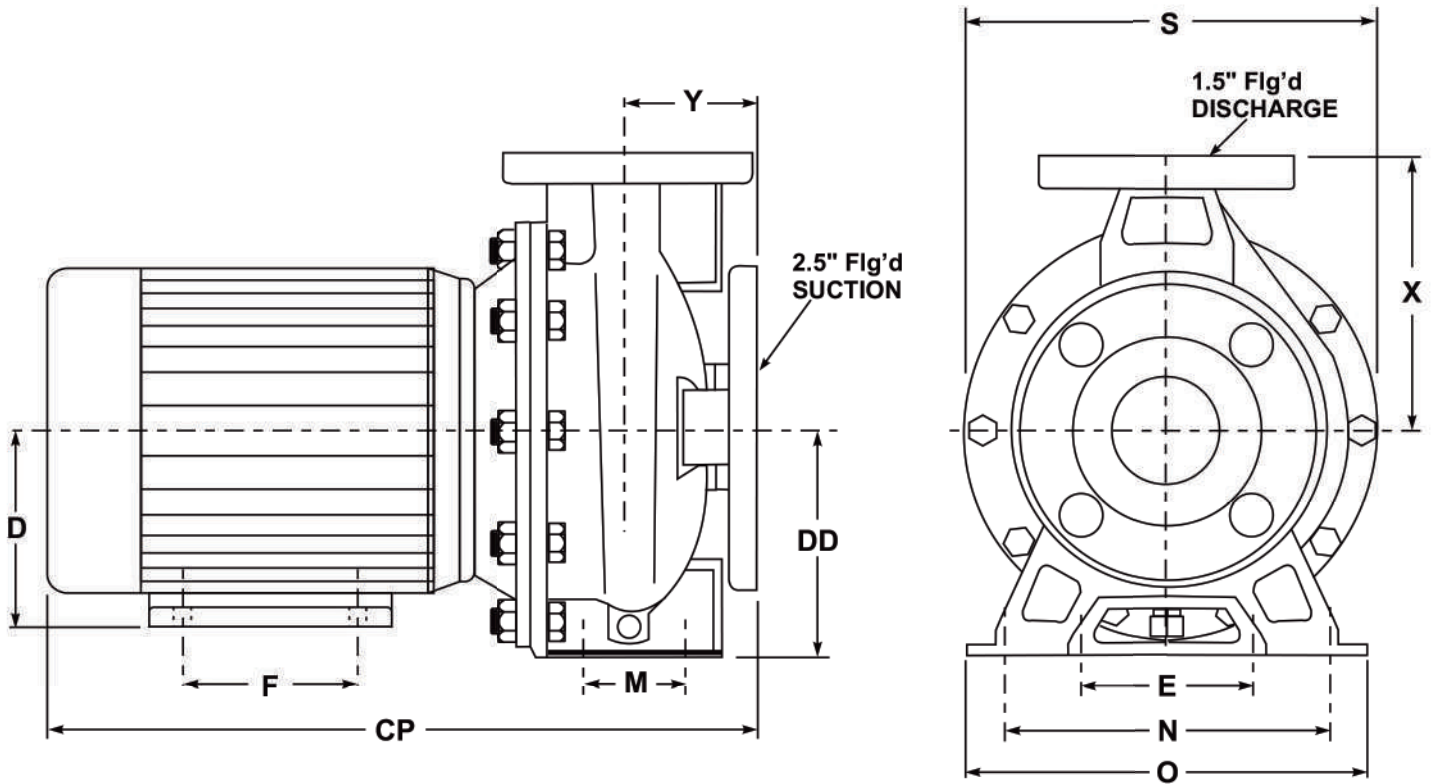

MOTOR FRAME	DIMENSIONS											WEIGHT (lbs)	
	CP*	F	E**	D	DD	M	N	O	S	X	Y	PUMP	MOTOR
143JM	17.75	4.0	5.5	3.50	6.31	2.75	8.38	10.44	11.56	7.06	3.94	21	44
145JM	18.75	5.0	5.5	3.50	6.31	2.75	8.38	10.44	11.56	7.06	3.94	21	44
182JM	19.50	4.5	7.5	4.50	6.31	2.75	8.38	10.44	11.56	7.06	3.94	21	90
184JM	20.50	5.5	7.5	4.50	6.31	2.75	8.38	10.44	11.56	7.06	3.94	21	110
213JM	22.25	5.5	8.5	5.25	6.31	2.75	8.38	10.44	11.56	7.06	3.94	21	120
215JM	23.75	7.0	8.5	5.25	6.31	2.75	8.38	10.44	11.56	7.06	3.94	21	160

NOTES - Not for construction purposes unless certified above.
 - All dimensions in inches.
 - Some dimensions may vary +/- 0.25 inches.
 - * Approximate only.
 - ** Motor mount hole spacing.



SERIES PS - DIMENSIONAL OUTLINE

MODEL - PSF1206

CUSTOMER - _____
 CUSTOMER REF. - _____ OUR REF. - _____
 HP - _____ RPM - _____ VOLTAGE - _____ ENCL. - _____

CERTIFIED - _____ DATE - _____

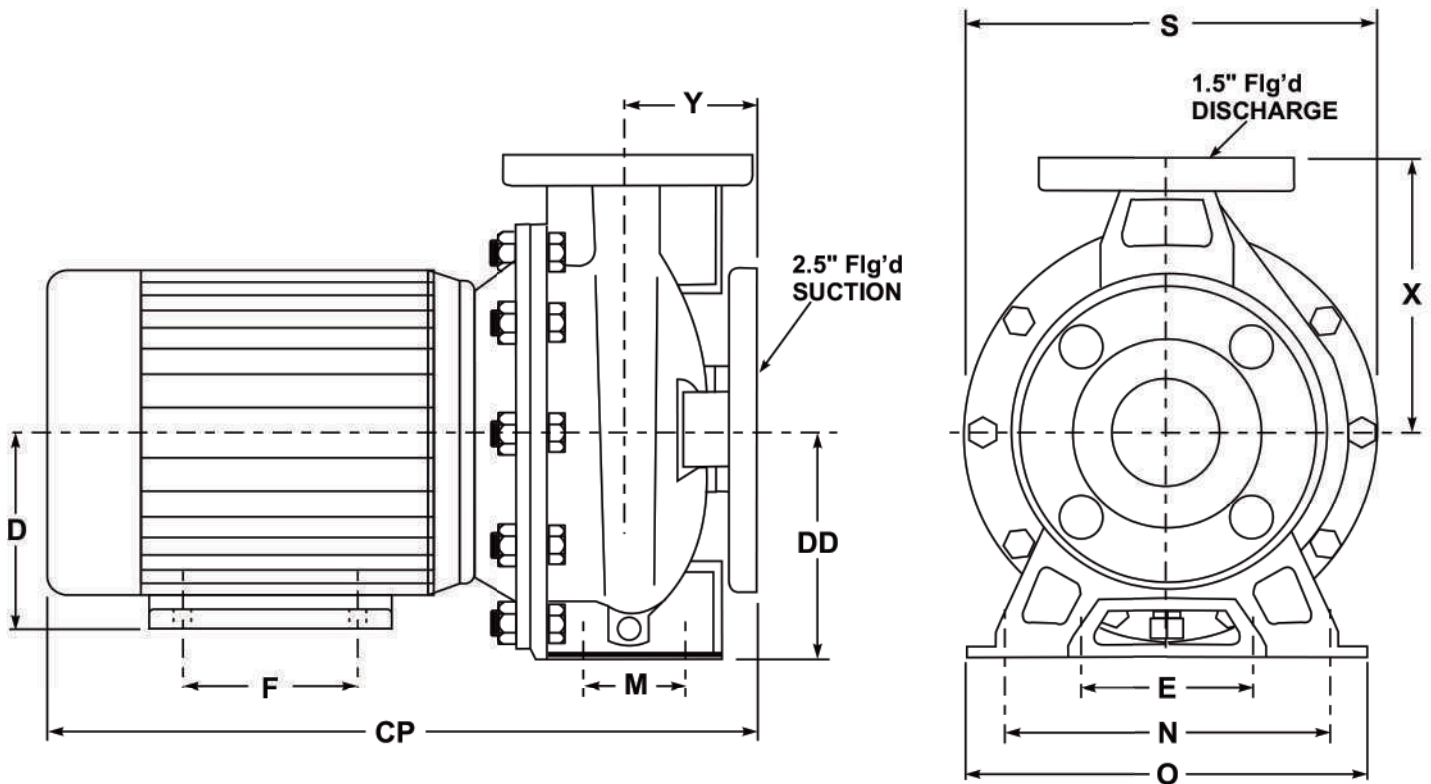

MOTOR FRAME	DIMENSIONS											WEIGHT (lbs)	
	CP*	F	E**	D	DD	M	N	O	S	X	Y	PUMP	MOTOR
143JM	17.75	4.0	5.5	3.50	6.31	2.75	8.38	10.44	11.56	7.06	3.94	21	44
145JM	18.75	5.0	5.5	3.50	6.31	2.75	8.38	10.44	11.56	7.06	3.94	21	44
182JM	19.50	4.5	7.5	4.50	6.31	2.75	8.38	10.44	11.56	7.06	3.94	21	90
184JM	20.50	5.5	7.5	4.50	6.31	2.75	8.38	10.44	11.56	7.06	3.94	21	110
213JM	22.25	5.5	8.5	5.25	6.31	2.75	8.38	10.44	11.56	7.06	3.94	21	120
215JM	23.75	7.0	8.5	5.25	6.31	2.75	8.38	10.44	11.56	7.06	3.94	21	160

NOTES - Not for construction purposes unless certified above.
 - All dimensions in inches.
 - Some dimensions may vary +/- 0.25 inches.
 - * Approximate only.
 - ** Motor mount hole spacing.



SERIES PS - DIMENSIONAL OUTLINE
MODEL - PSF2001

CUSTOMER - _____
 CUSTOMER REF. - _____ OUR REF. - _____
 HP - _____ RPM - _____ VOLTAGE - _____ ENCL. - _____

CERTIFIED - _____ DATE - _____

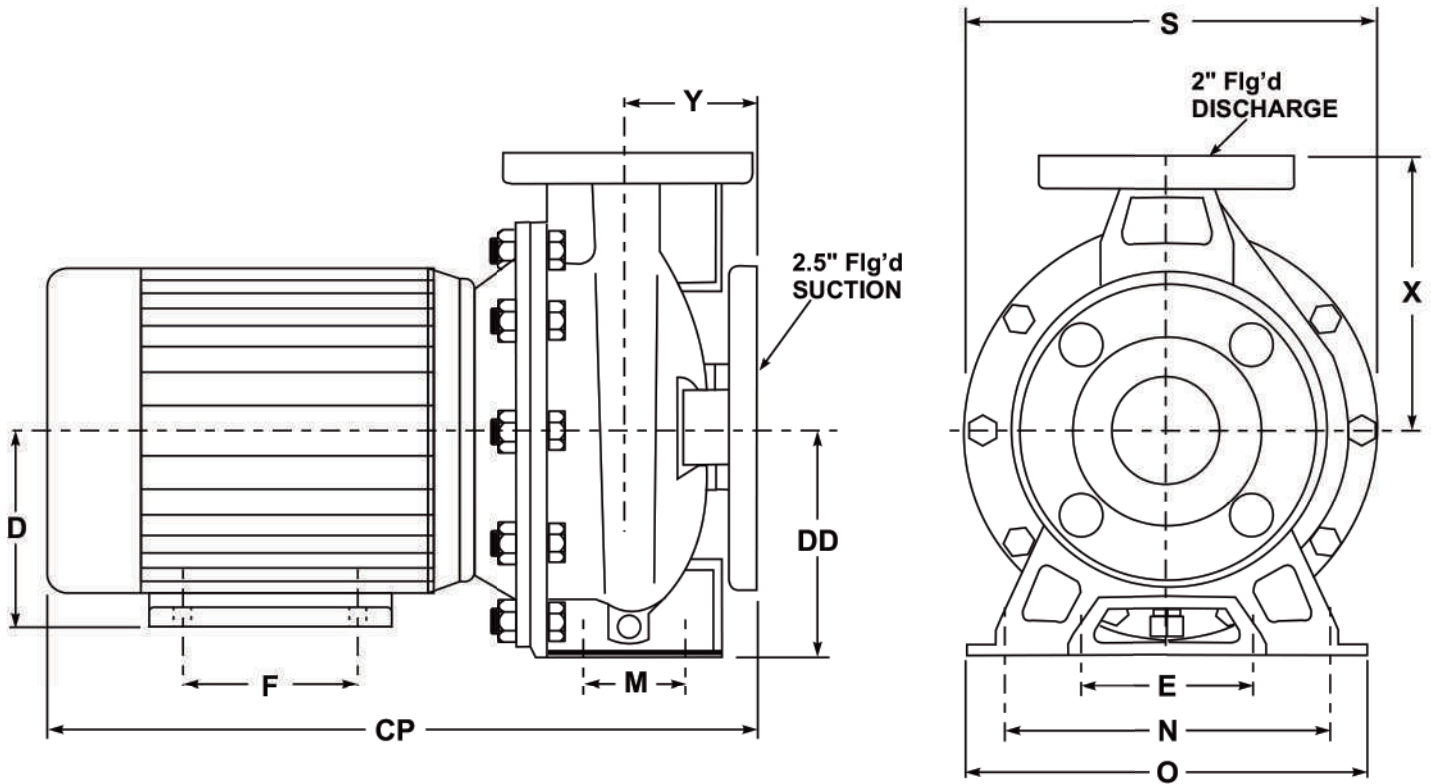

MOTOR FRAME	DIMENSIONS											WEIGHT (lbs)	
	CP*	F	E**	D	DD	M	N	O	S	X	Y	PUMP	MOTOR
143JM	17.75	4.0	5.5	3.50	5.19	2.75	7.5	9.44	10	6.31	3.94	22	44
145JM	18.75	5.0	5.5	3.50	5.19	2.75	7.5	9.44	10	6.31	3.94	22	44
182JM	19.50	4.5	7.5	4.50	5.19	2.75	7.5	9.44	10	6.31	3.94	22	90
184JM	20.50	5.5	7.5	4.50	5.19	2.75	7.5	9.44	10	6.31	3.94	22	110
213JM	22.25	5.5	8.5	5.25	5.19	2.75	7.5	9.44	10	6.31	3.94	22	120
215JM	23.75	7.0	8.5	5.25	5.19	2.75	7.5	9.44	10	6.31	3.94	22	160

NOTES - Not for construction purposes unless certified above.
 - All dimensions in inches.
 - Some dimensions may vary +/- 0.25 inches.
 - * Approximate only.
 - ** Motor mount hole spacing.



SERIES PS - DIMENSIONAL OUTLINE
MODEL - PSF2002

CUSTOMER - _____
 CUSTOMER REF. - _____ OUR REF. - _____
 HP - _____ RPM - _____ VOLTAGE - _____ ENCL. - _____

CERTIFIED - _____ DATE - _____

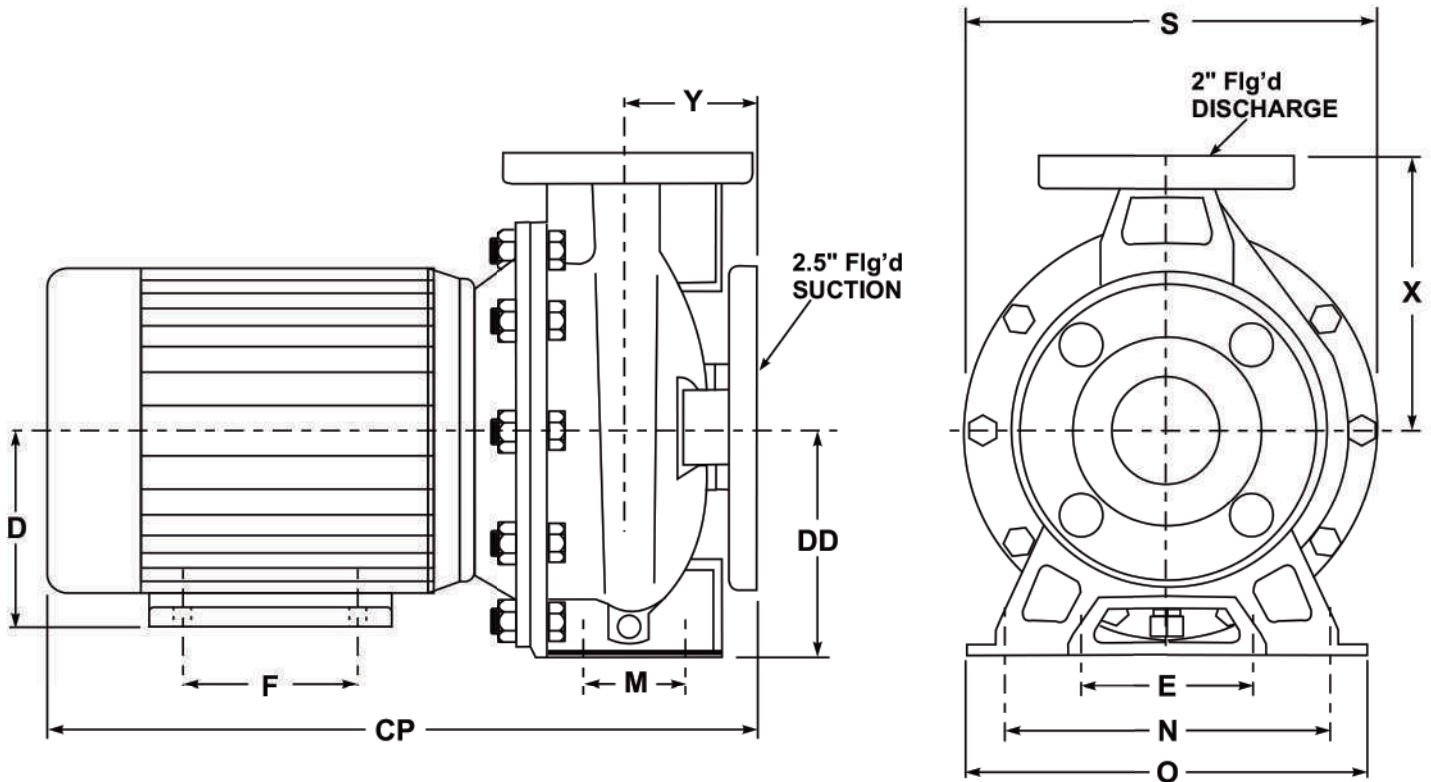

MOTOR FRAME	DIMENSIONS											WEIGHT (lbs)	
	CP*	F	E**	D	DD	M	N	O	S	X	Y	PUMP	MOTOR
143JM	17.75	4.0	5.5	3.50	5.19	2.75	7.5	9.44	10	6.31	3.94	22	44
145JM	18.75	5.0	5.5	3.50	5.19	2.75	7.5	9.44	10	6.31	3.94	22	44
182JM	19.50	4.5	7.5	4.50	5.19	2.75	7.5	9.44	10	6.31	3.94	22	90
184JM	20.50	5.5	7.5	4.50	5.19	2.75	7.5	9.44	10	6.31	3.94	22	110
213JM	22.25	5.5	8.5	5.25	5.19	2.75	7.5	9.44	10	6.31	3.94	22	120
215JM	23.75	7.0	8.5	5.25	5.19	2.75	7.5	9.44	10	6.31	3.94	22	160

NOTES - Not for construction purposes unless certified above.
 - All dimensions in inches.
 - Some dimensions may vary +/- 0.25 inches.
 - * Approximate only.
 - ** Motor mount hole spacing.



SERIES PS - DIMENSIONAL OUTLINE

MODEL - PSF2003

CUSTOMER - _____
 CUSTOMER REF. - _____ OUR REF. - _____
 HP - _____ RPM - _____ VOLTAGE - _____ ENCL. - _____

CERTIFIED - _____ DATE - _____

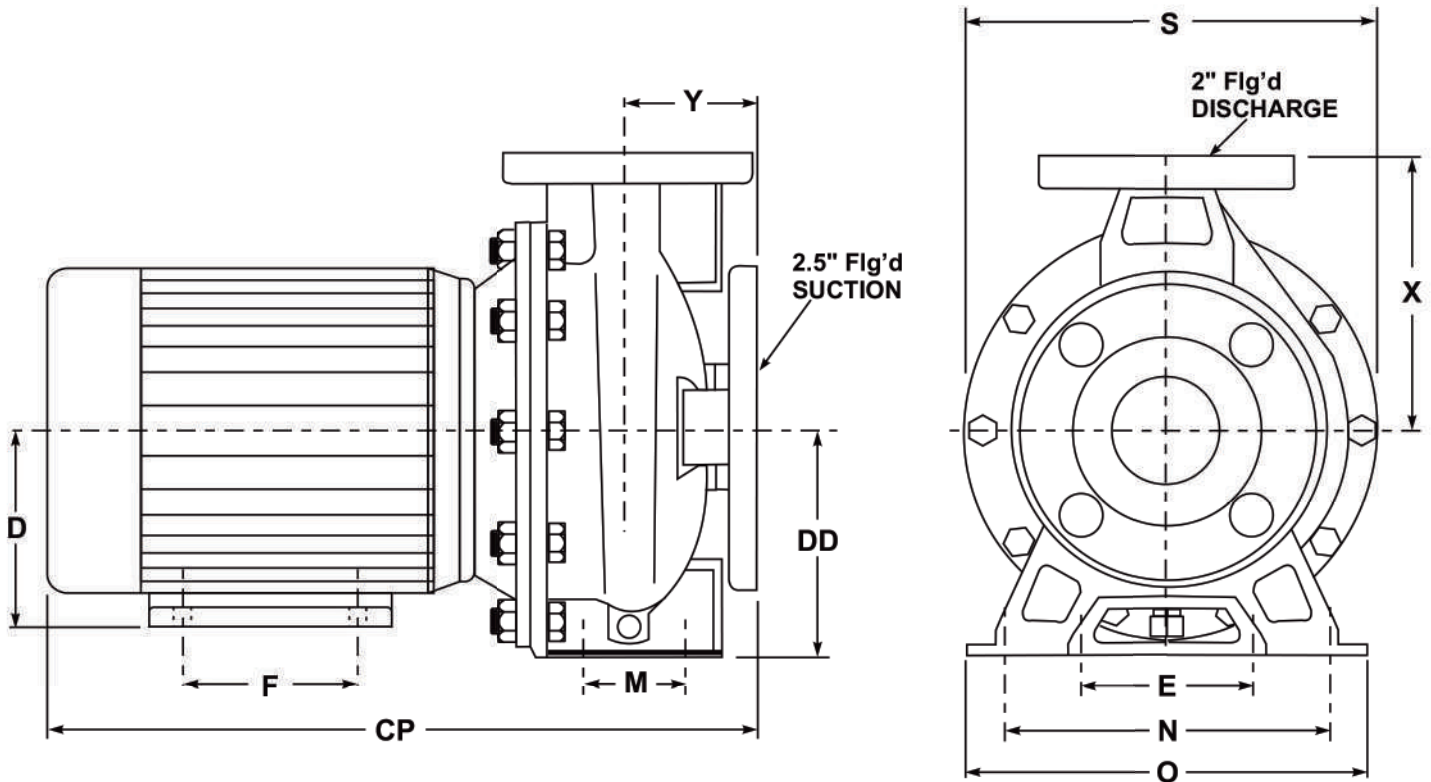

MOTOR FRAME	DIMENSIONS											WEIGHT (lbs)	
	CP*	F	E**	D	DD	M	N	O	S	X	Y	PUMP	MOTOR
143JM	17.75	4.0	5.5	3.50	6.31	2.75	8.38	10.44	11.69	7.06	3.94	22	44
145JM	18.75	5.0	5.5	3.50	6.31	2.75	8.38	10.44	11.69	7.06	3.94	22	44
182JM	19.50	4.5	7.5	4.50	6.31	2.75	8.38	10.44	11.69	7.06	3.94	22	90
184JM	20.50	5.5	7.5	4.50	6.31	2.75	8.38	10.44	11.69	7.06	3.94	22	110
213JM	22.25	5.5	8.5	5.25	6.31	2.75	8.38	10.44	11.69	7.06	3.94	22	120
215JM	23.75	7.0	8.5	5.25	6.31	2.75	8.38	10.44	11.69	7.06	3.94	22	160

NOTES - Not for construction purposes unless certified above.
 - All dimensions in inches.
 - Some dimensions may vary +/- 0.25 inches.
 - * Approximate only.
 - ** Motor mount hole spacing.



SERIES PS - DIMENSIONAL OUTLINE
MODEL - PSF2004

CUSTOMER - _____
 CUSTOMER REF. - _____ OUR REF. - _____
 HP - _____ RPM - _____ VOLTAGE - _____ ENCL. - _____

CERTIFIED - _____ DATE - _____

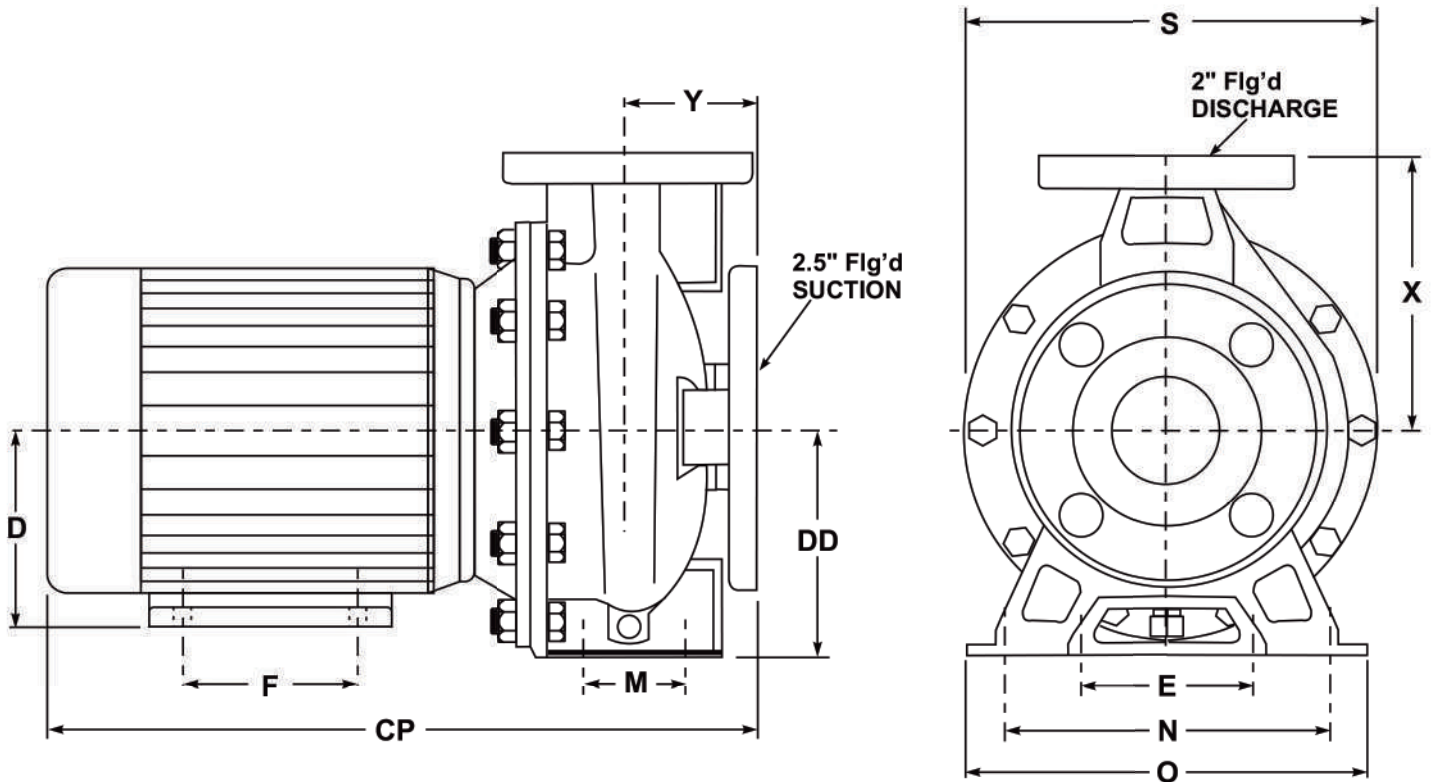

MOTOR FRAME	DIMENSIONS											WEIGHT (lbs)	
	CP*	F	E**	D	DD	M	N	O	S	X	Y	PUMP	MOTOR
143JM	17.75	4.0	5.5	3.50	6.31	2.75	8.38	10.44	11.69	7.06	3.94	22	44
145JM	18.75	5.0	5.5	3.50	6.31	2.75	8.38	10.44	11.69	7.06	3.94	22	44
182JM	19.50	4.5	7.5	4.50	6.31	2.75	8.38	10.44	11.69	7.06	3.94	22	90
184JM	20.50	5.5	7.5	4.50	6.31	2.75	8.38	10.44	11.69	7.06	3.94	22	110
213JM	22.25	5.5	8.5	5.25	6.31	2.75	8.38	10.44	11.69	7.06	3.94	22	120
215JM	23.75	7.0	8.5	5.25	6.31	2.75	8.38	10.44	11.69	7.06	3.94	22	160

NOTES - Not for construction purposes unless certified above.
 - All dimensions in inches.
 - Some dimensions may vary +/- 0.25 inches.
 - * Approximate only.
 - ** Motor mount hole spacing.



SERIES PS - DIMENSIONAL OUTLINE
MODEL - PSF3001 thru PSF3004

CUSTOMER - _____
 CUSTOMER REF. - _____ OUR REF. - _____
 HP - _____ RPM - _____ VOLTAGE - _____ ENCL. - _____

CERTIFIED - _____ DATE - _____

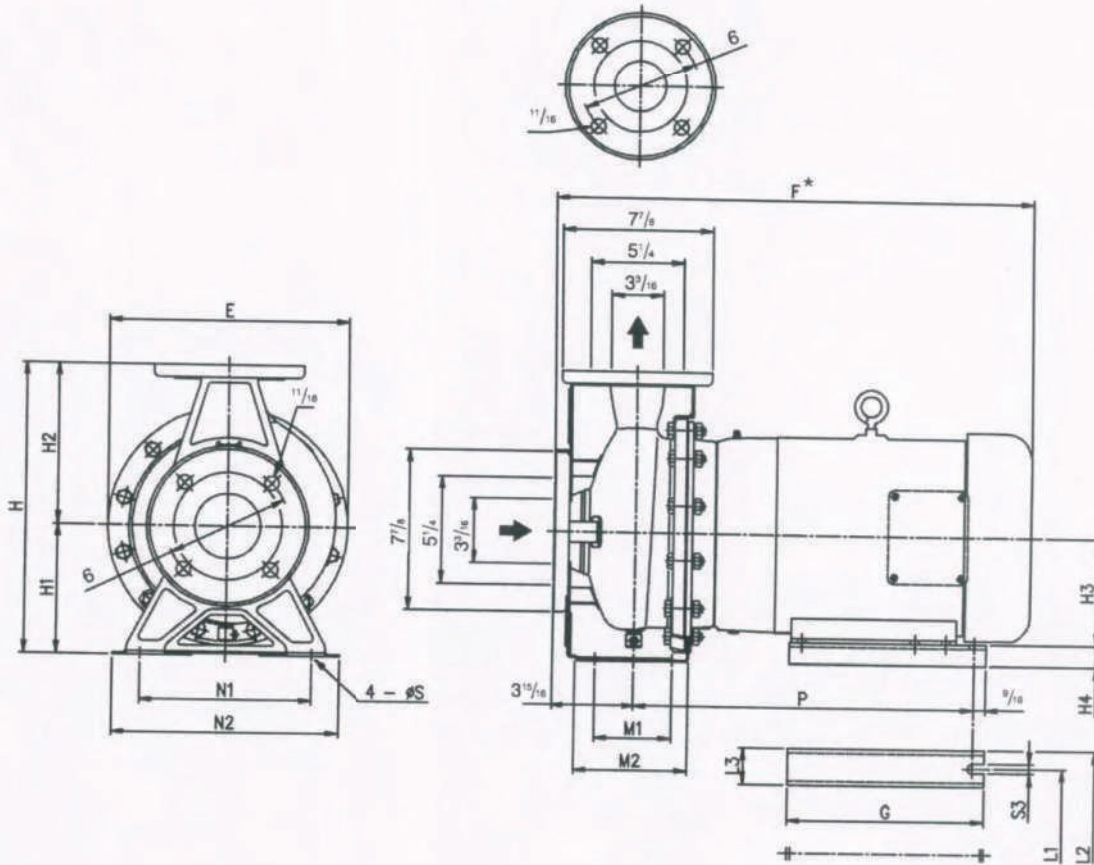

Dimensions: inch

MODEL	SIZE	TYPE	E	F	G	H	H ₁	H ₂	H ₃	H ₄	L ₁	L ₂	L ₃	M ₁	M ₂	N ₁	N ₂	P	S	S ₃
PSF3001/7.5	2 1/2 x 3 x 4 7/8	1	10	23 3/16	9 9/16	13 3/8	6 5/16	7 1/8	5 1/4	1 1/16	8 1/2	10 1/4	1 3/4	3 3/4	5 1/2	8 5/8	11	16 9/16	9/16	1/2
PSF3002/10	2 1/2 x 3 x 5 1/8	1	10	23 3/16	9 9/16	13 3/8	6 5/16	7 1/8	5 1/4	1 1/16	8 1/2	10 1/4	1 3/4	3 3/4	5 1/2	8 5/8	11	16 9/16	9/16	1/2
PSF3003/10	2 1/2 x 3 x 5 3/8	1	11 1/8	23 3/16	9 9/16	14 3/16	6 5/16	7 1/8	5 1/4	1 1/16	8 1/2	10 1/4	1 3/4	3 3/4	5 1/2	8 5/8	11	16 9/16	9/16	1/2
PSF3004/15	2 1/2 x 3 x 5 7/8	1	11 5/8	23 3/16	9 9/16	14 3/16	6 5/16	7 1/8	5 1/4	1 1/16	8 1/2	10 1/4	1 3/4	3 3/4	5 1/2	8 5/8	11	16 9/16	9/16	1/2

NOTES - Not for construction purposes unless certified above.
 - All dimensions in inches.
 - * Approximate only.



SERIES PS - DIMENSIONAL OUTLINE
MODEL - PSF3005 thru PSF3009

CUSTOMER - _____
 CUSTOMER REF. - _____ OUR REF. - _____
 HP - _____ RPM - _____ VOLTAGE - _____ ENCL. - _____

CERTIFIED - _____ DATE - _____

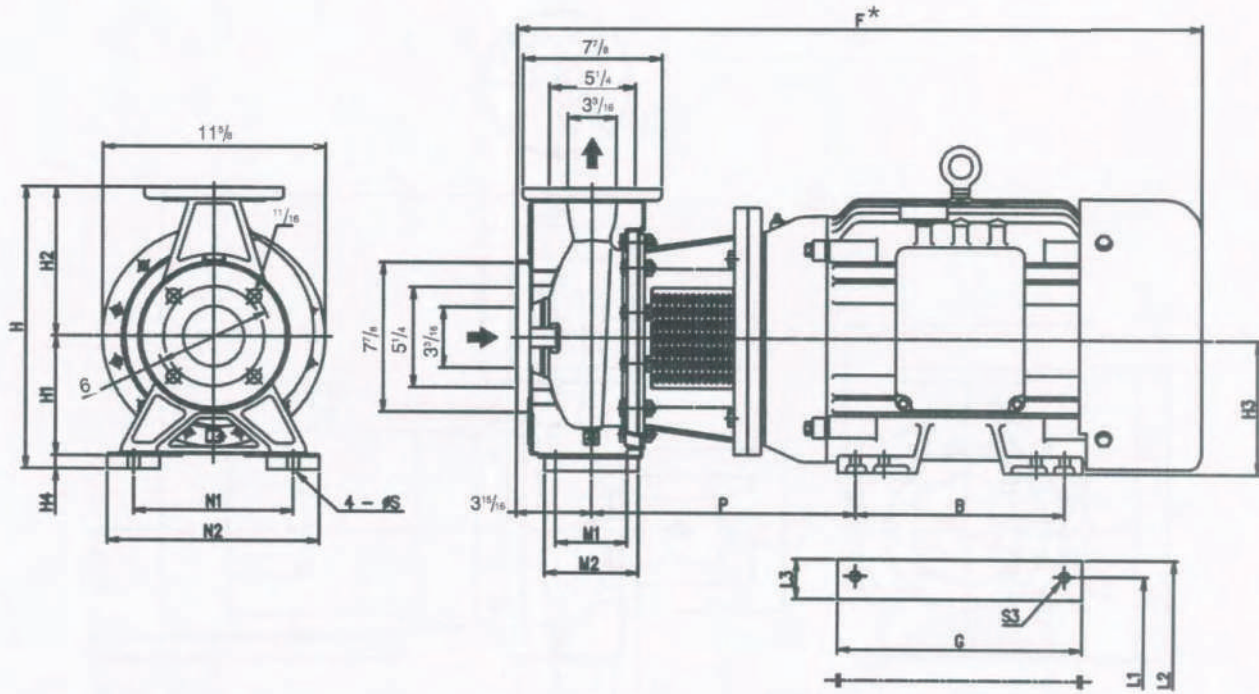

Dimensions: inch

MODEL	SIZE	TYPE	B	F	G	H	H ₁	H ₂	H ₃	H ₄	L ₁	L ₂	L ₃	M ₁	M ₂	N ₁	N ₂	P	S	S ₃
PSF3005/20	2 1/2 x 3 x 6 5/16	3	10	32 3/16	11 5/8	14 3/16	6 9/16	7 1/8	6 1/4	1/16	10	12 3/4	2 3/8	3 3/4	5 1/2	8 3/8	11	13 13/16	9/16	17/32
PSF3006/25	2 1/2 x 3 x 6 7/8	3	11	36	12 13/16	14 7/8	6 9/16	7 1/8	7	11/16	11	12 3/4	-	3 3/4	4 15/16	8 3/8	11 1/8	13 7/8	9/16	17/32
PSF3007/20	2 1/2 x 3 x 6 3/4	3	9 1/4	32 3/16	13 3/16	15 13/16	7 1/16	8 7/8	6 1/4	13/16	10	12 3/4	2 3/8	3 3/4	5 1/2	9 13/16	12 5/8	25 13/16	9/16	9/16
PSF3008/25	2 1/2 x 3 x 7 1/16	3	11	36	13	15 13/16	7 1/16	8 7/8	7	1/16	11	12 15/16	1 15/16	3 3/4	5 1/2	9 13/16	12 5/8	13 7/8	9/16	17/32
PSF3009/30	2 1/2 x 3 x 7 1/2	3	11	36	13	15 13/16	7 1/16	8 7/8	7	1/16	11	12 15/16	1 15/16	3 3/4	5 1/2	9 13/16	12 5/8	13 7/8	9/16	17/32

NOTES - Not for construction purposes unless certified above.
 - All dimensions in inches.
 - * Approximate only.



**SERIES PS - DIMENSIONAL OUTLINE
MODEL - PSF701**

CUSTOMER - _____
 CUSTOMER REF. - _____ OUR REF. - _____
 HP - _____ RPM - _____ VOLTAGE - _____ ENCL. - _____

CERTIFIED - _____ DATE - _____

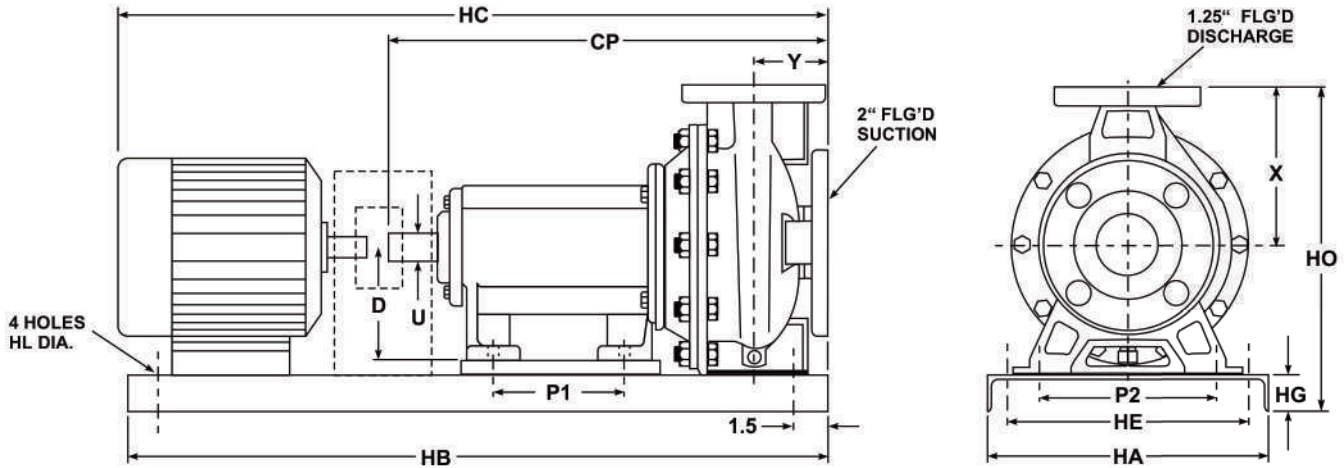

MOTOR FRAME	DIMENSIONS														WEIGHT (lbs)*		
	HA	HB	HL	HC*	HO	HG	HE	CP	P1	P2	D**	U	X	Y	PUMP	MOTOR	ASS'Y
56	10	35	0.62	33.0	13.38	2.62	7.0	20.5	5.75	5.62	5.25	1.25	5.50	3.12	80	30	155
143T	10	35	0.62	34.0	13.38	2.62	7.0	20.5	5.75	5.62	5.25	1.25	5.50	3.12	80	40	165
145T	10	35	0.62	34.0	13.38	2.62	7.0	20.5	5.75	5.62	5.25	1.25	5.50	3.12	80	40	165
182T	10	35	0.62	35.0	13.38	2.62	7.0	20.5	5.75	5.62	5.25	1.25	5.50	3.12	80	80	205
184T	10	35	0.62	35.0	13.38	2.62	7.0	20.5	5.75	5.62	5.25	1.25	5.50	3.12	80	80	205

NOTES - Not for construction purposes unless certified above.
 - All dimensions in inches.
 - Some dimensions may vary +/- 0.25 inches.
 - * Approximate only.
 - ** Shaft centerline to underside of frame feet.



SERIES PS - DIMENSIONAL OUTLINE
MODEL - PSF702

CUSTOMER - _____
 CUSTOMER REF. - _____ OUR REF. - _____
 HP - _____ RPM - _____ VOLTAGE - _____ ENCL. - _____

CERTIFIED - _____ DATE - _____

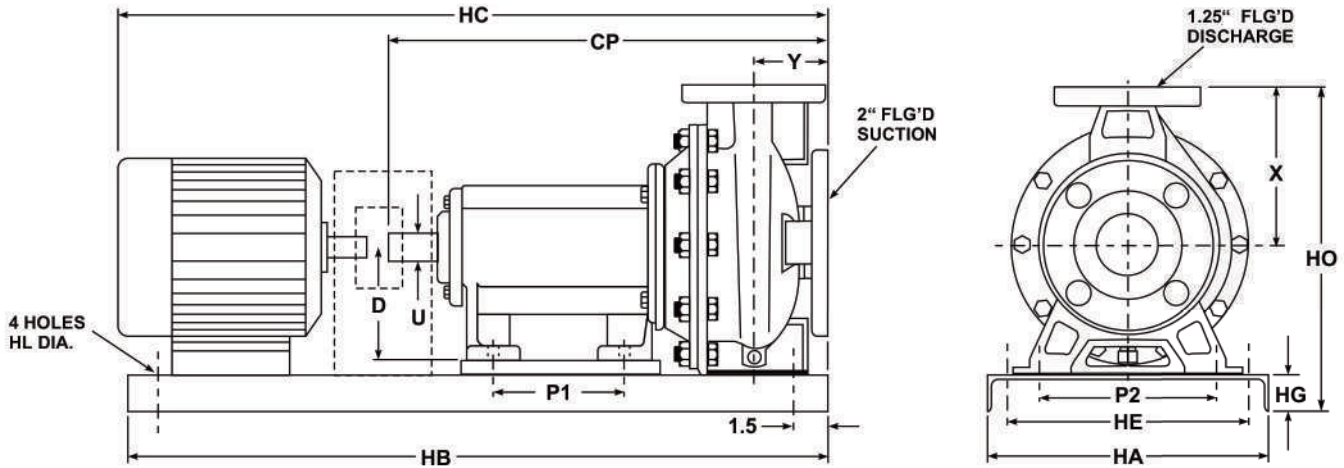

MOTOR FRAME	DIMENSIONS														WEIGHT (lbs)*		
	HA	HB	HL	HC*	HO	HG	HE	CP	P1	P2	D**	U	X	Y	PUMP	MOTOR	ASS'Y
56	10	35	0.62	33.0	14.81	2.62	7.0	20.5	5.75	5.62	5.25	1.25	6.31	3.12	80	30	155
143T	10	35	0.62	34.0	14.81	2.62	7.0	20.5	5.75	5.62	5.25	1.25	6.31	3.12	80	40	165
145T	10	35	0.62	34.0	14.81	2.62	7.0	20.5	5.75	5.62	5.25	1.25	6.31	3.12	80	40	165
182T	10	35	0.62	35.0	14.81	2.62	7.0	20.5	5.75	5.62	5.25	1.25	6.31	3.12	80	80	205
184T	10	35	0.62	35.0	14.81	2.62	7.0	20.5	5.75	5.62	5.25	1.25	6.31	3.12	80	80	205

NOTES - Not for construction purposes unless certified above.
 - All dimensions in inches.
 - Some dimensions may vary +/- 0.25 inches.
 - * Approximate only.
 - ** Shaft centerline to underside of frame feet.



**SERIES PS - DIMENSIONAL OUTLINE
MODEL - PSF703**

CUSTOMER - _____
 CUSTOMER REF. - _____ OUR REF. - _____
 HP - _____ RPM - _____ VOLTAGE - _____ ENCL. - _____

CERTIFIED - _____ DATE - _____

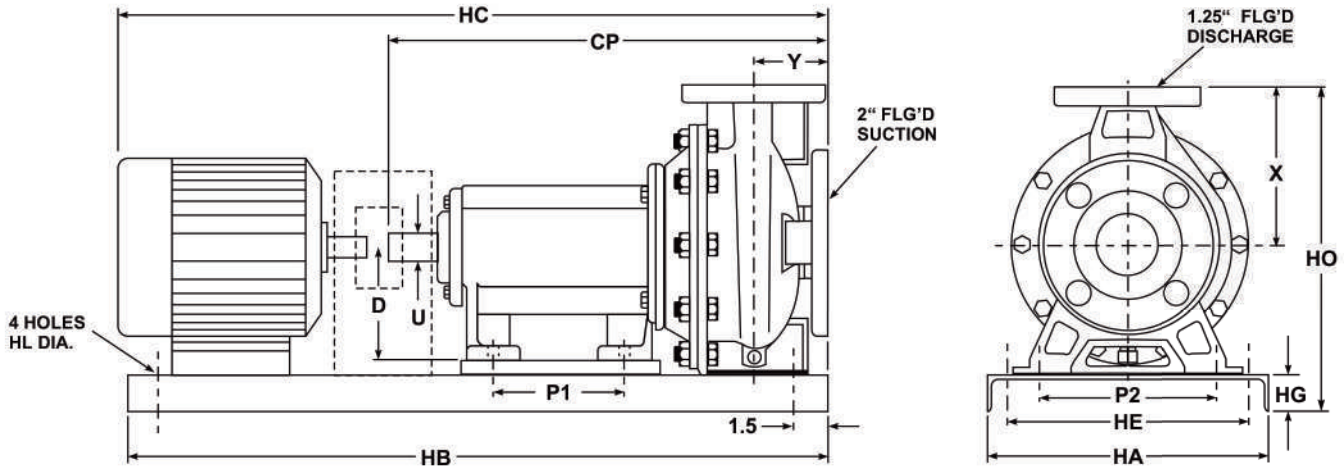

MOTOR FRAME	DIMENSIONS														WEIGHT (lbs)*		
	HA	HB	HL	HC*	HO	HG	HE	CP	P1	P2	D**	U	X	Y	PUMP	MOTOR	ASS'Y
56	10	35	0.62	33.0	14.81	2.62	7.0	20.5	5.75	5.62	5.25	1.25	6.31	3.12	80	30	155
143T	10	35	0.62	34.0	14.81	2.62	7.0	20.5	5.75	5.62	5.25	1.25	6.31	3.12	80	40	165
145T	10	35	0.62	34.0	14.81	2.62	7.0	20.5	5.75	5.62	5.25	1.25	6.31	3.12	80	40	165
182T	10	35	0.62	35.0	14.81	2.62	7.0	20.5	5.75	5.62	5.25	1.25	6.31	3.12	80	80	205
184T	10	35	0.62	35.0	14.81	2.62	7.0	20.5	5.75	5.62	5.25	1.25	6.31	3.12	80	80	205

NOTES - Not for construction purposes unless certified above.
 - All dimensions in inches.
 - Some dimensions may vary +/- 0.25 inches.
 - * Approximate only.
 - ** Shaft centerline to underside of frame feet.



**SERIES PS - DIMENSIONAL OUTLINE
MODEL - PSF704**

CUSTOMER - _____
 CUSTOMER REF. - _____ OUR REF. - _____
 HP - _____ RPM - _____ VOLTAGE - _____ ENCL. - _____

CERTIFIED - _____ DATE - _____

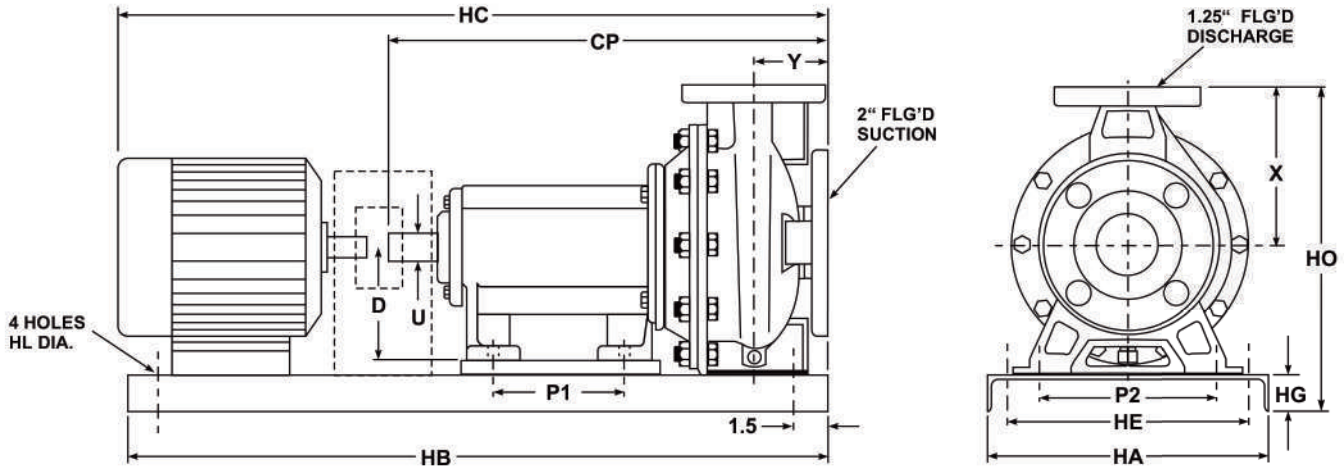

MOTOR FRAME	DIMENSIONS														WEIGHT (lbs)*		
	HA	HB	HL	HC*	HO	HG	HE	CP	P1	P2	D**	U	X	Y	PUMP	MOTOR	ASS'Y
56	10	35	0.62	33.0	16.06	2.62	7.0	20.88	5.75	5.62	5.25	1.25	7.06	3.12	80	30	155
143T	10	35	0.62	34.0	16.06	2.62	7.0	20.88	5.75	5.62	5.25	1.25	7.06	3.12	80	40	165
145T	10	35	0.62	34.0	16.06	2.62	7.0	20.88	5.75	5.62	5.25	1.25	7.06	3.12	80	40	165
182T	10	35	0.62	35.0	16.06	2.62	7.0	20.88	5.75	5.62	5.25	1.25	7.06	3.12	80	80	205
184T	10	35	0.62	35.0	16.06	2.62	7.0	20.88	5.75	5.62	5.25	1.25	7.06	3.12	80	80	205
213T	12	40	0.62	39.0	16.44	3.00	9.0	20.88	5.75	5.62	5.25	1.25	7.06	3.12	80	150	275
215T	12	40	0.62	39.0	16.44	3.00	9.0	20.88	5.75	5.62	5.25	1.25	7.06	3.12	80	150	275

NOTES - Not for construction purposes unless certified above.
 - All dimensions in inches.
 - Some dimensions may vary +/- 0.25 inches.
 - * Approximate only.
 - ** Shaft centerline to underside of frame feet.



SERIES PS - DIMENSIONAL OUTLINE
MODEL - PSF705

CUSTOMER - _____
 CUSTOMER REF. - _____ OUR REF. - _____
 HP - _____ RPM - _____ VOLTAGE - _____ ENCL. - _____

CERTIFIED - _____ DATE - _____

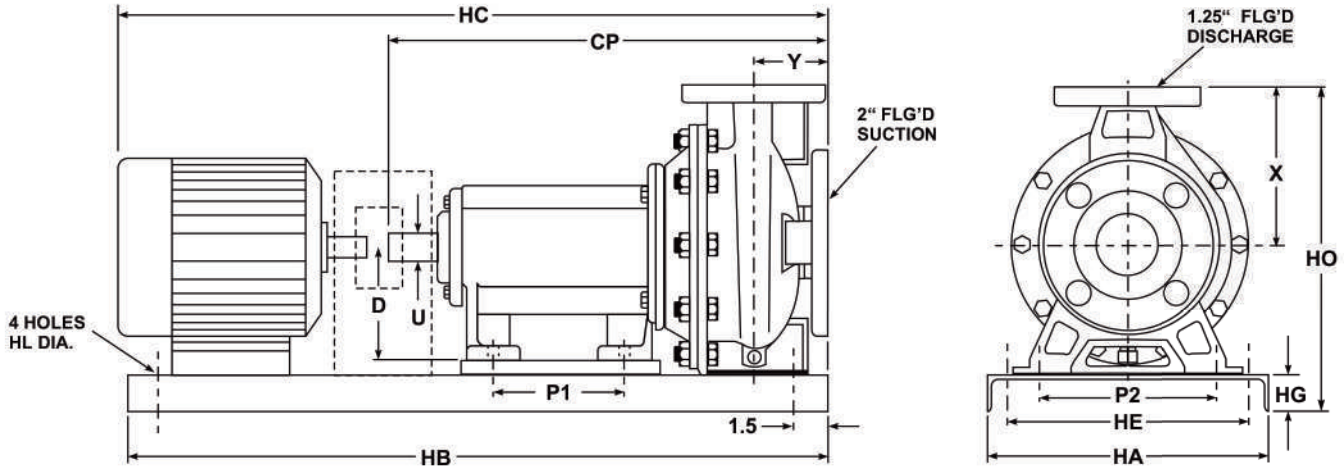

MOTOR FRAME	DIMENSIONS														WEIGHT (lbs)*		
	HA	HB	HL	HC*	HO	HG	HE	CP	P1	P2	D**	U	X	Y	PUMP	MOTOR	ASS'Y
56	10	35	0.62	33.0	16.06	2.62	7.0	20.88	5.75	5.62	5.25	1.25	7.06	3.12	80	30	155
143T	10	35	0.62	34.0	16.06	2.62	7.0	20.88	5.75	5.62	5.25	1.25	7.06	3.12	80	40	165
145T	10	35	0.62	34.0	16.06	2.62	7.0	20.88	5.75	5.62	5.25	1.25	7.06	3.12	80	40	165
182T	10	35	0.62	35.0	16.06	2.62	7.0	20.88	5.75	5.62	5.25	1.25	7.06	3.12	80	80	205
184T	10	35	0.62	35.0	16.06	2.62	7.0	20.88	5.75	5.62	5.25	1.25	7.06	3.12	80	80	205
213T	12	40	0.62	39.0	16.44	3.00	9.0	20.88	5.75	5.62	5.25	1.25	7.06	3.12	80	150	275
215T	12	40	0.62	39.0	16.44	3.00	9.0	20.88	5.75	5.62	5.25	1.25	7.06	3.12	80	150	275

NOTES - Not for construction purposes unless certified above.
 - All dimensions in inches.
 - Some dimensions may vary +/- 0.25 inches.
 - * Approximate only.
 - ** Shaft centerline to underside of frame feet.



SERIES PS - DIMENSIONAL OUTLINE
MODEL - PSF1201

CUSTOMER - _____
 CUSTOMER REF. - _____ OUR REF. - _____
 HP - _____ RPM - _____ VOLTAGE - _____ ENCL. - _____

CERTIFIED - _____ DATE - _____

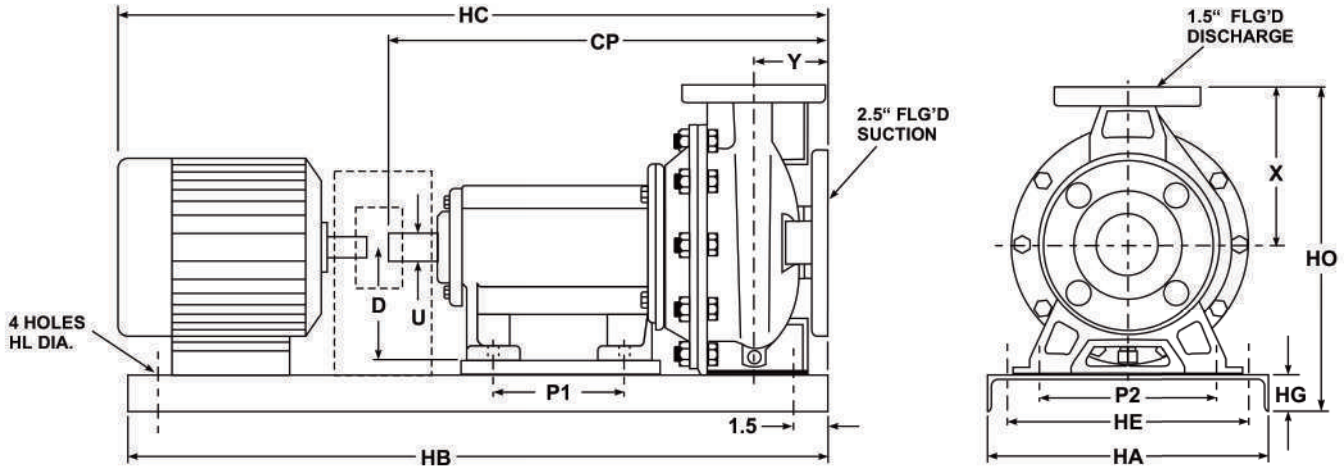

MOTOR FRAME	DIMENSIONS														WEIGHT (lbs)*		
	HA	HB	HL	HC*	HO	HG	HE	CP	P1	P2	D**	U	X	Y	PUMP	MOTOR	ASS'Y
56	10	35	0.62	32.0	13.38	2.62	7.0	20.12	5.75	5.62	5.25	1.25	5.50	3.12	80	30	155
143T	10	35	0.62	33.0	13.38	2.62	7.0	20.12	5.75	5.62	5.25	1.25	5.50	3.12	80	40	165
145T	10	35	0.62	33.0	13.38	2.62	7.0	20.12	5.75	5.62	5.25	1.25	5.50	3.12	80	40	165
182T	10	35	0.62	34.0	13.38	2.62	7.0	20.12	5.75	5.62	5.25	1.25	5.50	3.12	80	80	205
184T	10	35	0.62	34.0	13.38	2.62	7.0	20.12	5.75	5.62	5.25	1.25	5.50	3.12	80	80	205

NOTES - Not for construction purposes unless certified above.
 - All dimensions in inches.
 - Some dimensions may vary +/- 0.25 inches.
 - * Approximate only.
 - ** Shaft centerline to underside of frame feet.



SERIES PS - DIMENSIONAL OUTLINE
MODEL - PSF1202

CUSTOMER - _____
 CUSTOMER REF. - _____ OUR REF. - _____
 HP - _____ RPM - _____ VOLTAGE - _____ ENCL. - _____

CERTIFIED - _____ DATE - _____

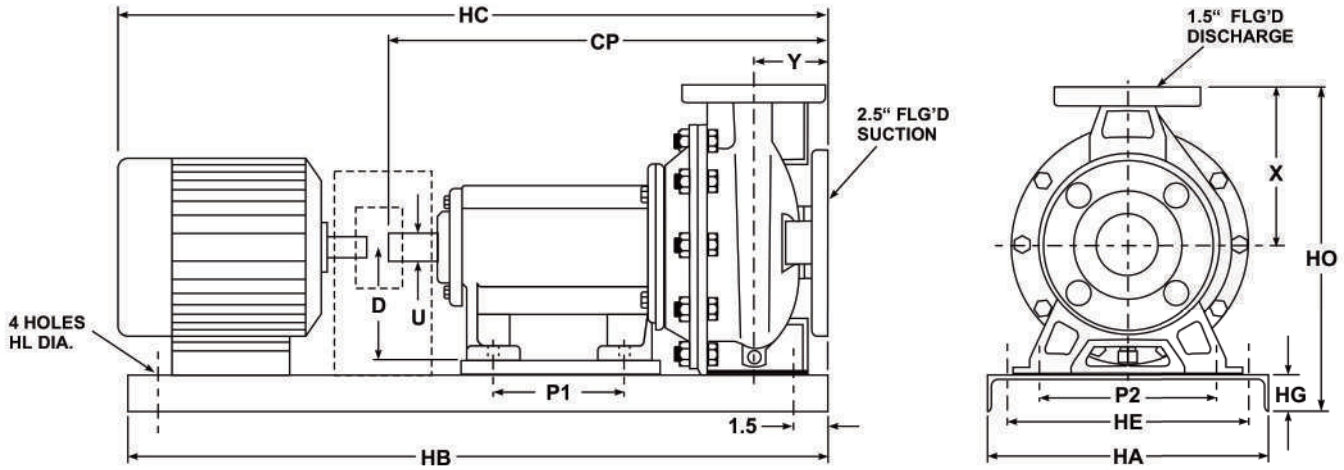

MOTOR FRAME	DIMENSIONS														WEIGHT (lbs)*		
	HA	HB	HL	HC*	HO	HG	HE	CP	P1	P2	D**	U	X	Y	PUMP	MOTOR	ASS'Y
56	10	35	0.62	32.0	13.38	2.62	7.0	20.12	5.75	5.62	5.25	1.25	5.50	3.12	80	30	155
143T	10	35	0.62	33.0	13.38	2.62	7.0	20.12	5.75	5.62	5.25	1.25	5.50	3.12	80	40	165
145T	10	35	0.62	33.0	13.38	2.62	7.0	20.12	5.75	5.62	5.25	1.25	5.50	3.12	80	40	165
182T	10	35	0.62	34.0	13.38	2.62	7.0	20.12	5.75	5.62	5.25	1.25	5.50	3.12	80	80	205
184T	10	35	0.62	34.0	13.38	2.62	7.0	20.12	5.75	5.62	5.25	1.25	5.50	3.12	80	80	205

NOTES - Not for construction purposes unless certified above.
 - All dimensions in inches.
 - Some dimensions may vary +/- 0.25 inches.
 - * Approximate only.
 - ** Shaft centerline to underside of frame feet.



SERIES PS - DIMENSIONAL OUTLINE
MODEL - PSF1203

CUSTOMER - _____
 CUSTOMER REF. - _____ OUR REF. - _____
 HP - _____ RPM - _____ VOLTAGE - _____ ENCL. - _____

CERTIFIED - _____ DATE - _____

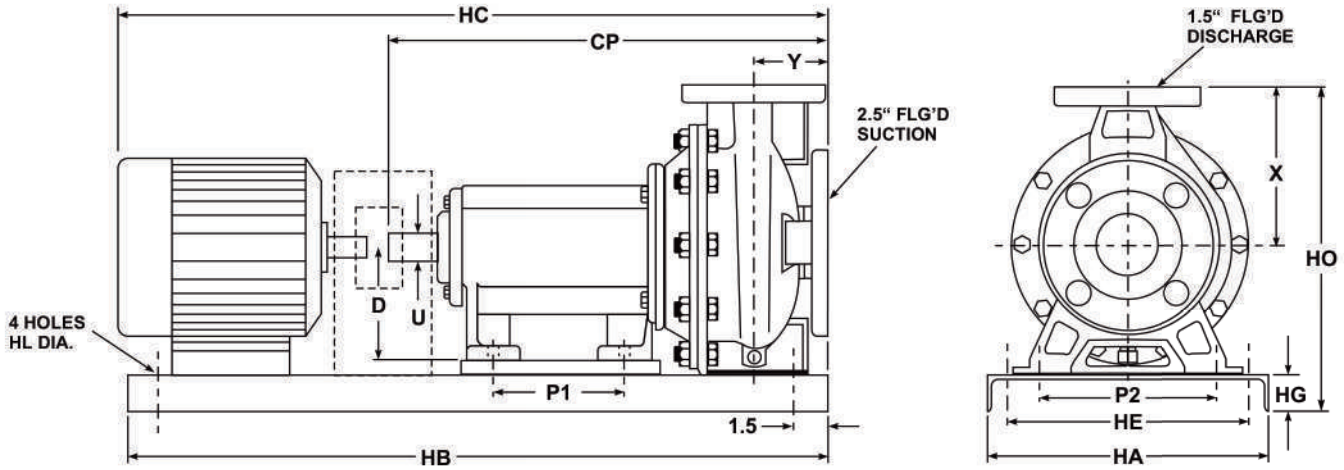

MOTOR FRAME	DIMENSIONS														WEIGHT (lbs)*		
	HA	HB	HL	HC*	HO	HG	HE	CP	P1	P2	D**	U	X	Y	PUMP	MOTOR	ASS'Y
56	10	35	0.62	33.0	14.19	2.62	7.0	21.0	5.75	5.62	5.25	1.25	6.31	3.12	85	30	160
143T	10	35	0.62	34.0	14.19	2.62	7.0	21.0	5.75	5.62	5.25	1.25	6.31	3.12	85	40	170
145T	10	35	0.62	34.0	14.19	2.62	7.0	21.0	5.75	5.62	5.25	1.25	6.31	3.12	85	40	170
182T	10	35	0.62	35.0	14.19	2.62	7.0	21.0	5.75	5.62	5.25	1.25	6.31	3.12	85	80	210
184T	10	35	0.62	35.0	14.19	2.62	7.0	21.0	5.75	5.62	5.25	1.25	6.31	3.12	85	80	210
213T	12	40	0.62	39.0	14.56	3.00	9.0	21.0	5.75	5.62	5.25	1.25	6.31	3.12	85	150	370
215T	12	40	0.62	39.0	14.56	3.00	9.0	21.0	5.75	5.62	5.25	1.25	6.31	3.12	85	150	370

NOTES - Not for construction purposes unless certified above.
 - All dimensions in inches.
 - Some dimensions may vary +/- 0.25 inches.
 - * Approximate only.
 - ** Shaft centerline to underside of frame feet.



SERIES PS - DIMENSIONAL OUTLINE
MODEL - PSF1204

CUSTOMER - _____
 CUSTOMER REF. - _____ OUR REF. - _____
 HP - _____ RPM - _____ VOLTAGE - _____ ENCL. - _____

CERTIFIED - _____ DATE - _____

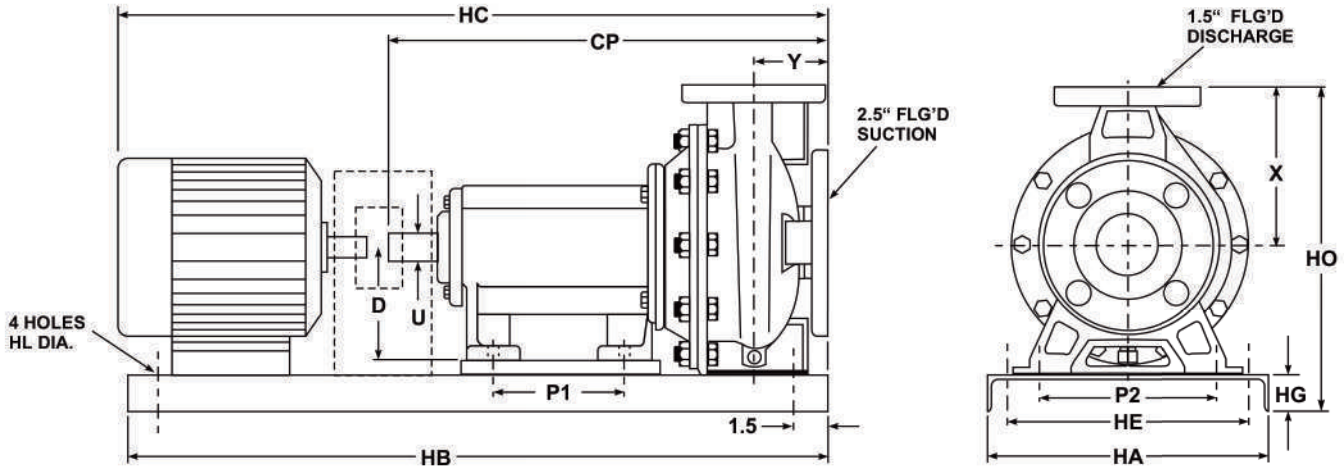

MOTOR FRAME	DIMENSIONS														WEIGHT (lbs)*		
	HA	HB	HL	HC*	HO	HG	HE	CP	P1	P2	D**	U	X	Y	PUMP	MOTOR	ASS'Y
56	10	35	0.62	33.0	14.19	2.62	7.0	21.0	5.75	5.62	5.25	1.25	6.31	3.12	85	30	160
143T	10	35	0.62	34.0	14.19	2.62	7.0	21.0	5.75	5.62	5.25	1.25	6.31	3.12	85	40	170
145T	10	35	0.62	34.0	14.19	2.62	7.0	21.0	5.75	5.62	5.25	1.25	6.31	3.12	85	40	170
182T	10	35	0.62	35.0	14.19	2.62	7.0	21.0	5.75	5.62	5.25	1.25	6.31	3.12	85	80	210
184T	10	35	0.62	35.0	14.19	2.62	7.0	21.0	5.75	5.62	5.25	1.25	6.31	3.12	85	80	210
213T	12	40	0.62	39.0	14.56	3.00	9.0	21.0	5.75	5.62	5.25	1.25	6.31	3.12	85	150	370
215T	12	40	0.62	39.0	14.56	3.00	9.0	21.0	5.75	5.62	5.25	1.25	6.31	3.12	85	150	370

NOTES - Not for construction purposes unless certified above.
 - All dimensions in inches.
 - Some dimensions may vary +/- 0.25 inches.
 - * Approximate only.
 - ** Shaft centerline to underside of frame feet.



SERIES PS - DIMENSIONAL OUTLINE
MODEL - PSF1205

CUSTOMER - _____
 CUSTOMER REF. - _____ OUR REF. - _____
 HP - _____ RPM - _____ VOLTAGE - _____ ENCL. - _____

CERTIFIED - _____ DATE - _____

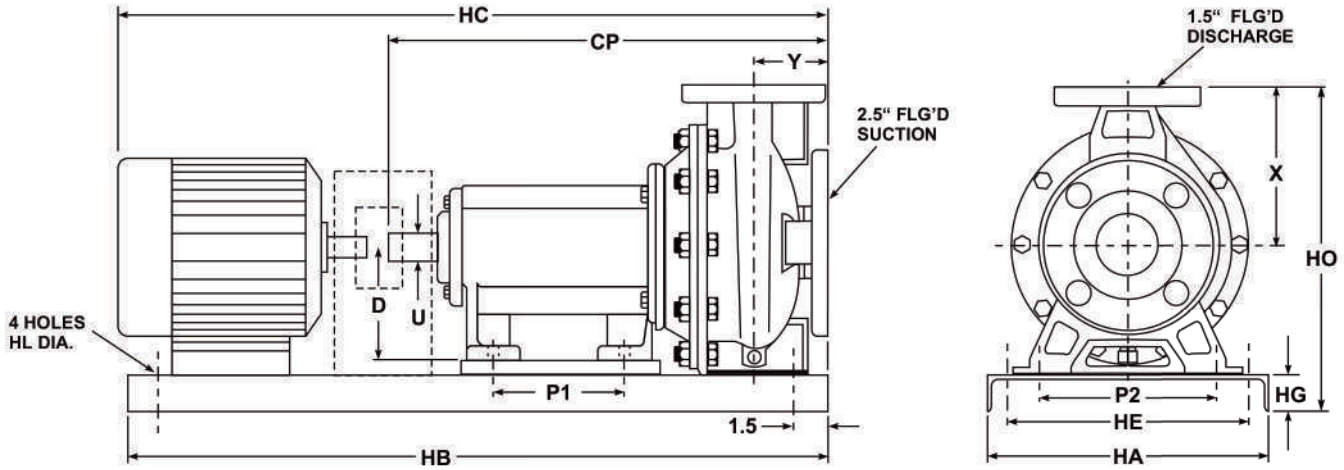

MOTOR FRAME	DIMENSIONS														WEIGHT (lbs)*		
	HA	HB	HL	HC*	HO	HG	HE	CP	P1	P2	D**	U	X	Y	PUMP	MOTOR	ASS'Y
56	10	35	0.62	34.0	16.06	2.62	7.0	22.0	5.75	5.62	5.25	1.25	7.06	3.94	85	30	160
143T	10	35	0.62	34.0	16.06	2.62	7.0	22.0	5.75	5.62	5.25	1.25	7.06	3.94	85	40	170
145T	10	35	0.62	34.0	16.06	2.62	7.0	22.0	5.75	5.62	5.25	1.25	7.06	3.94	85	40	170
182T	10	35	0.62	35.0	16.06	2.62	7.0	22.0	5.75	5.62	5.25	1.25	7.06	3.94	85	80	210
184T	10	35	0.62	35.0	16.06	2.62	7.0	22.0	5.75	5.62	5.25	1.25	7.06	3.94	85	80	210
213T	12	40	0.62	41.0	16.44	3.00	9.0	22.0	5.75	5.62	5.25	1.25	7.06	3.94	85	150	365
215T	12	40	0.62	41.0	16.44	3.00	9.0	22.0	5.75	5.62	5.25	1.25	7.06	3.94	85	150	365
254T	15	48	0.75	46.0	16.81	3.38	12.0	22.0	5.75	5.62	5.25	1.25	7.06	3.94	85	250	490

NOTES - Not for construction purposes unless certified above.
 - All dimensions in inches.
 - Some dimensions may vary +/- 0.25 inches.
 - * Approximate only.
 - ** Shaft centerline to underside of frame feet.



SERIES PS - DIMENSIONAL OUTLINE
MODEL - PSF1206

CUSTOMER - _____
 CUSTOMER REF. - _____ OUR REF. - _____
 HP - _____ RPM - _____ VOLTAGE - _____ ENCL. - _____

CERTIFIED - _____ DATE - _____

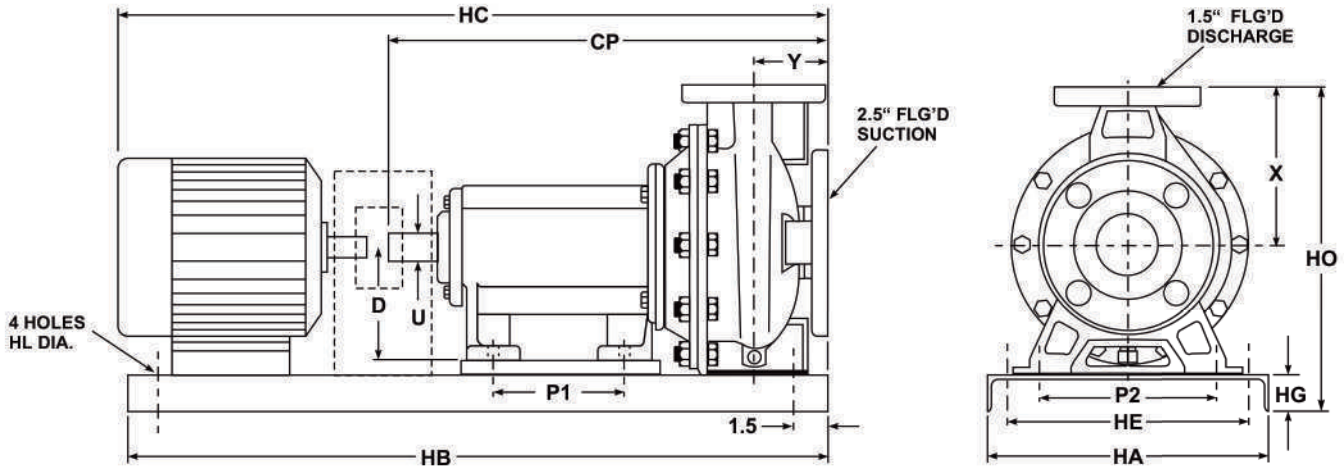

MOTOR FRAME	DIMENSIONS														WEIGHT (lbs)*		
	HA	HB	HL	HC*	HO	HG	HE	CP	P1	P2	D**	U	X	Y	PUMP	MOTOR	ASS'Y
56	10	35	0.62	34.0	16.06	2.62	7.0	22.0	5.75	5.62	5.25	1.25	7.06	3.94	85	30	160
143T	10	35	0.62	34.0	16.06	2.62	7.0	22.0	5.75	5.62	5.25	1.25	7.06	3.94	85	40	170
145T	10	35	0.62	34.0	16.06	2.62	7.0	22.0	5.75	5.62	5.25	1.25	7.06	3.94	85	40	170
182T	10	35	0.62	35.0	16.06	2.62	7.0	22.0	5.75	5.62	5.25	1.25	7.06	3.94	85	80	210
184T	10	35	0.62	35.0	16.06	2.62	7.0	22.0	5.75	5.62	5.25	1.25	7.06	3.94	85	80	210
213T	12	40	0.62	41.0	16.44	3.00	9.0	22.0	5.75	5.62	5.25	1.25	7.06	3.94	85	150	365
215T	12	40	0.62	41.0	16.44	3.00	9.0	22.0	5.75	5.62	5.25	1.25	7.06	3.94	85	150	365
254T	15	48	0.75	46.0	16.81	3.38	12.0	22.0	5.75	5.62	5.25	1.25	7.06	3.94	85	250	490

NOTES - Not for construction purposes unless certified above.
 - All dimensions in inches.
 - Some dimensions may vary +/- 0.25 inches.
 - * Approximate only.
 - ** Shaft centerline to underside of frame feet.



SERIES PS - DIMENSIONAL OUTLINE
MODEL - PSF2001

CUSTOMER - _____
 CUSTOMER REF. - _____ OUR REF. - _____
 HP - _____ RPM - _____ VOLTAGE - _____ ENCL. - _____

CERTIFIED - _____ DATE - _____

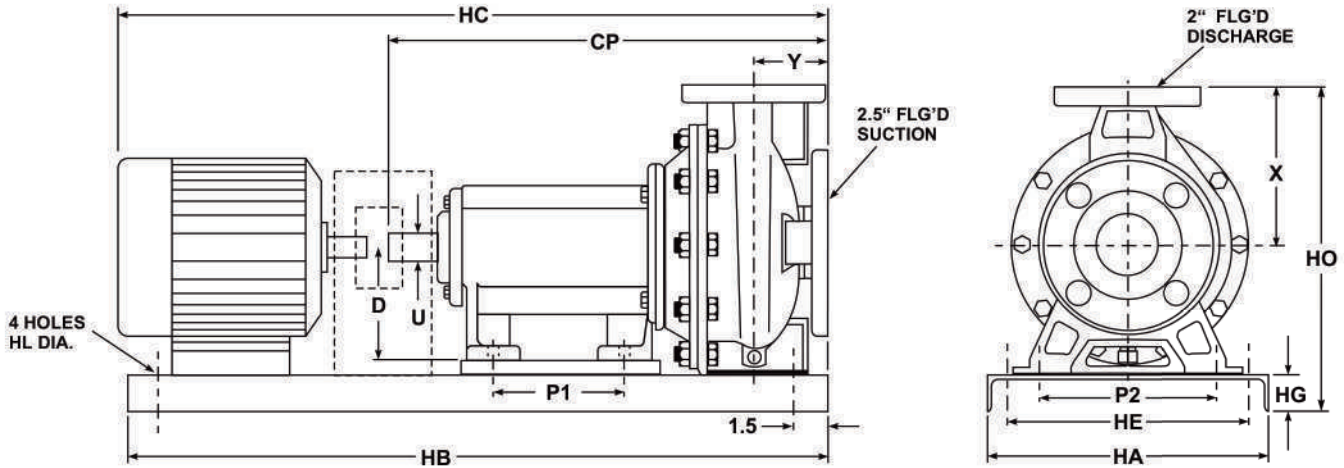

MOTOR FRAME	DIMENSIONS														WEIGHT (lbs)*		
	HA	HB	HL	HC*	HO	HG	HE	CP	P1	P2	D**	U	X	Y	PUMP	MOTOR	ASS'Y
56	10	35	0.62	33.0	14.19	2.62	7.0	22.0	5.75	5.62	5.25	1.25	6.31	3.94	90	30	165
143T	10	35	0.62	34.0	14.19	2.62	7.0	22.0	5.75	5.62	5.25	1.25	6.31	3.94	90	40	175
145T	10	35	0.62	34.0	14.19	2.62	7.0	22.0	5.75	5.62	5.25	1.25	6.31	3.94	90	40	175
182T	10	35	0.62	35.0	14.19	2.62	7.0	22.0	5.75	5.62	5.25	1.25	6.31	3.94	90	80	215
184T	10	35	0.62	35.0	14.19	2.62	7.0	22.0	5.75	5.62	5.25	1.25	6.31	3.94	90	80	215
213T	12	40	0.62	40.0	14.56	3.00	9.0	22.0	5.75	5.62	5.25	1.25	6.31	3.94	90	150	370
215T	12	40	0.62	40.0	14.56	3.00	9.0	22.0	5.75	5.62	5.25	1.25	6.31	3.94	90	150	370

NOTES - Not for construction purposes unless certified above.
 - All dimensions in inches.
 - Some dimensions may vary +/- 0.25 inches.
 - * Approximate only.
 - ** Shaft centerline to underside of frame feet.



SERIES PS - DIMENSIONAL OUTLINE
MODEL - PSF2002

CUSTOMER - _____
 CUSTOMER REF. - _____ OUR REF. - _____
 HP - _____ RPM - _____ VOLTAGE - _____ ENCL. - _____

CERTIFIED - _____ DATE - _____

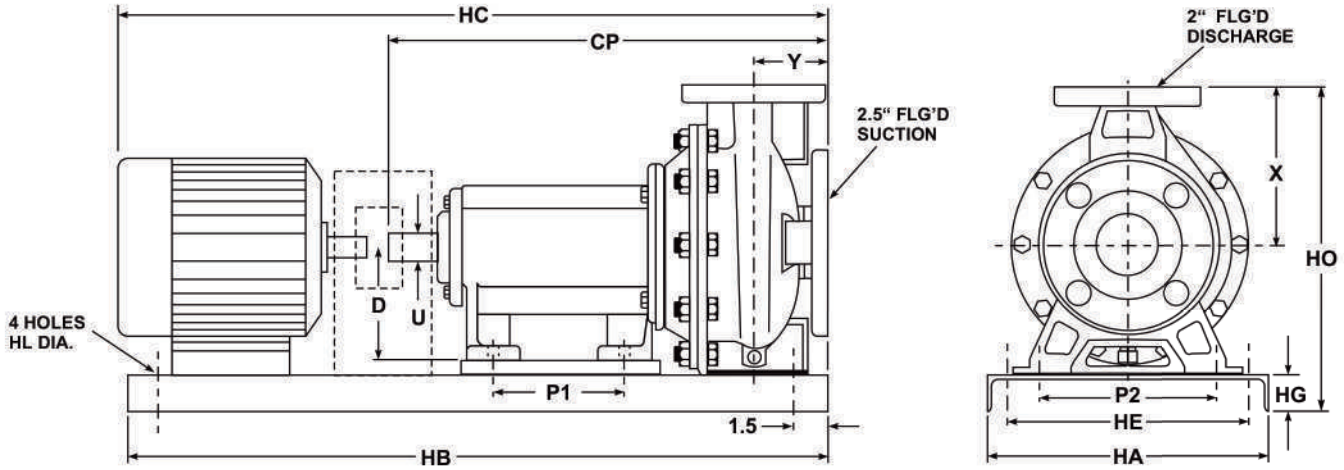

MOTOR FRAME	DIMENSIONS														WEIGHT (lbs)*		
	HA	HB	HL	HC*	HO	HG	HE	CP	P1	P2	D**	U	X	Y	PUMP	MOTOR	ASS'Y
56	10	35	0.62	33.0	14.19	2.62	7.0	22.0	5.75	5.62	5.25	1.25	6.31	3.94	90	30	165
143T	10	35	0.62	34.0	14.19	2.62	7.0	22.0	5.75	5.62	5.25	1.25	6.31	3.94	90	40	175
145T	10	35	0.62	34.0	14.19	2.62	7.0	22.0	5.75	5.62	5.25	1.25	6.31	3.94	90	40	175
182T	10	35	0.62	35.0	14.19	2.62	7.0	22.0	5.75	5.62	5.25	1.25	6.31	3.94	90	80	215
184T	10	35	0.62	35.0	14.19	2.62	7.0	22.0	5.75	5.62	5.25	1.25	6.31	3.94	90	80	215
213T	12	40	0.62	40.0	14.56	3.00	9.0	22.0	5.75	5.62	5.25	1.25	6.31	3.94	90	150	370
215T	12	40	0.62	40.0	14.56	3.00	9.0	22.0	5.75	5.62	5.25	1.25	6.31	3.94	90	150	370

NOTES - Not for construction purposes unless certified above.
 - All dimensions in inches.
 - Some dimensions may vary +/- 0.25 inches.
 - * Approximate only.
 - ** Shaft centerline to underside of frame feet.

We are proud supplier for the following completed and on going projects :



Bethware Elementary High School
115 Bethware Dr, Kings Mountain, NC, United States



Old Montreal College
255 Ontario Est
Montreal, Quebec, CA



Ratiopharm Inc.
17800 Rue Lapointe,
Mirabel, QC, CA



Campus 99
5151 Côte-Ste-Catherine
Road, Montréal, QC, CA

Sales and Service:

Quebec, Canada
Tel. : (450) 621-2995
Fax : (450) 621-4995

Lake Worth
Florida, USA
33467-5749

Toronto, Canada
Tel. : +1 (647) 544-2995

www.flofab.com

SERVICE 24/7 : parts@flofab.com

