



# Submersible Pumps

**Sewage Cutter Pump - STO/FO**

**Drainage Pump - SF/SC**

**Sewage Pump - SS/SST/SM**

**Sewage Vortex Pump - SSM-V**

**Dewatering Pump - KS/KL**

**Contractor Pump - KT**

**Sewage Grinder Pump - GP/GPQ**



**STO/FO**



**KS/KL**



**SF/SC**



**SS/SST/SM**



**GP/GPQ**



**KT**



**SSM-V**

[www.flofab.com](http://www.flofab.com)

001-cat-2017-subm2

Go to [www.flofab.com](http://www.flofab.com) in Our Products Section to see the Master Spec - <http://www.arcomnet.com/masterspec/>



## HISTORY

Founder 1981



Flo Fab was established in 1981 by Denis Gauvreau who created and developed the products line and constantly being perfected by Marc Gauvreau, as well as by a team of professional engineers and designers. It's a combination of existing designs from several renowned products and the innovative ideas of a new generation professionals.

Through the years, Flo Fab has acquired several companies and service entities including : AQUA-PROFAB (ASME Tanks manufacturer), MÉNARD, LÉONARD ÉLECTRIQUE, PMA. , Furthermore Flo Fab purchased equipment, fabrication designs and patterns from IDEALCO, a manufacturer of shell and tube type heat exchangers.

The after sales services, sales, engineering, R&D, production, quality control, accounting and administration departments of all the above companies share the same location.

In December 2014, Marc Gauvreau, son of the founder, acquired all shares of The company. Flo Fab and is constantly investing in new state of the art innovations new product like the XRI series and Prefab Skid for Hydronic Heating & cooling system, pumping systems. This has allowed Flo Fab to retain competent and experienced staff of professionals with varied and specialized abilities that constantly work on improving our existing products and add new engineered solutions that exceeding customer's expectations .

Flo Fab has grown quite rapidly and now proudly offers of a wide range of products available directly from one manufacturer. This includes pumps & pump packages, tanks, heat exchangers & hydronic accessories. This allows each project stakeholders to enjoy economical savings, peace of mind, best value for their investment and optimized total cost of ownership.



# TABLE OF CONTENTS

<b>FLO FAB'S HISTORY</b> .....	2	<b>SPECIFICATIONS/DIM./AMPS (60HZ)</b> .....	45
<b>DETERMINATION OF THE REQUIRED SYSTEM CAPACITY</b> .....	4	<b>GP/GPQ SERIES</b>	
<b>HOW TO SELECT A PUMP MODEL</b> .....	5	<b>GP TYPE SUBMERSIBLE GRINDER PUMP</b> ..	46
<b>STO/STO-T/FO/FO-T SERIES</b>		<b>FEATURES</b> .....	47
<b>FEATURES/APPLICATION</b> .....	6	<b>SPECIFICATIONS/ PERF. CURVE</b> .....	48
<b>INSTALLATION/MAINTENANCE</b> .....	7	<b>DIMENSIONS</b> .....	49
<b>PICTURES OF ALL MODELS</b> .....	8	<b>SPECS./STAND. ACC. OF GUIDE RAIL KIT</b> ..	50
<b>SPECIFICATIONS</b> .....	9	<b>GPQ TYPE STAINLESS GRINDER PUMP</b> ..	51
<b>STANDARD ACCESSORIES</b> .....	10	<b>FEATURES</b> .....	52
<b>PERFORMANCE CURVES</b> .....	10	<b>SPECS/CURVES/DIM./CONSTR</b> .....	53
<b>STO DIMENSIONS</b> .....	11	<b>ACCESSORIES</b> .....	54-55
<b>STO-T DIMENSIONS</b> .....	12	<b>SLIDE AWAY COUPLING DRAWINGS</b>	
<b>FO/FO-T DIMENSIONS (MM)</b> .....	13	<b>LBV 25/40/75 c/w 2"</b>	
<b>FO/FO-T DIMENSIONS (IN)</b> .....	14	.....	56
<b>STO-C/FO-C SERIES</b>		<b>SLIDE AWAY COUPLING DRAWINGS</b>	
<b>FEATURES</b> .....	15	<b>FBV 3" &amp; 4"</b>	
<b>PICTURES OF ALL MODELS</b> .....	16	.....	57
<b>PERFORMANCE CURVES/DIMENSIONS</b> ....	17	<b>SLIDE AWAY COUPLING DRAWINGS</b>	
<b>CONSTRUCTIONS</b> .....	18	<b>FS 3" &amp; 4"</b>	
<b>FLOAT LEVEL CONTROL PANEL</b> .....	19	.....	58
<b>ELECTRICAL WIRING SCHEMATIC</b>		<b>18" to 60" FIBERGLASS BASINS</b> .....	59-65
<b>DIAGRAM</b> .....	19-20	<b>SIMPLEX METAL COVERS</b> .....	66-68
<b>SC/SCA SERIES</b>		<b>24" DUPLEX METAL COVERS</b> .....	69
<b>FEAT./APP./DIM./CONST./CURVES</b> .....	21	<b>30" FIBERGLASS DUPLEX COVERS</b> .....	70
<b>SPECIFICATION/AMPS/DIMENSIONS</b> .....	22	<b>DUPLEX METAL COVERS</b> .....	71
<b>SF/SFA SERIES</b>		<b>SIMPLEX SUBMERSIBLE</b> .....	72, 74, 76
<b>CONSTRUCTION/DIMENSION/CURVES</b> ....	23	<b>SIMPLEX SUBMERSIBLE</b>	
<b>DIAGRAM SC-112A</b> .....	24	<b>W/ SLIDE RAIL COUPLING</b> .....	73, 75, 77
<b>SPECIFICATIONS/DIMENSIONS</b> .....	25	<b>DUPLEX SUBMERSIBLE</b> .....	78
<b>SS/SSA/SST/ST/STA SERIES</b>		<b>W/ SLIDE AWAY COUPLING</b> .....	79
<b>FEATURES/APPLICATIONS/CONST</b> .....	26	<b>DUPLEX SUBMERSIBLE</b>	
<b>PERFORMANCE CURVES/DIMENSIONS</b> ....	27	<b>W/ SLIDE RAIL COUPLING</b> .....	80-82
<b>SPECIFICATIONS/DIMENSIONS</b> .....	28	<b>STANDARD FOR SIMPLEX SUBMERSIBLE</b>	
<b>SM/SSM/SMA SERIES</b>		<b>PANELS</b> .....	83-87
<b>FEAT./ APP./CURVES/DIMENSIONS</b> .....	29	<b>STANDARD FOR DUPLEX SUBMERSIBLE</b>	
<b>SPECIFICATIONS/DIMENSIONS</b> .....	30	<b>PANELS</b> .....	88-93
<b>SSM-V/SMA-V SERIES</b>			
<b>FEATURES</b> .....	31		
<b>SPECS./STAND. ACC. OF GUIDE RAIL KIT</b> ..	32		
<b>PERF. CURVES/CONSTRUCTIONS</b> .....	33		
<b>DIMENSIONS</b> .....	34-35		
<b>SPECIFICATIONS/AMPS</b> .....	36		
<b>KL/KS SERIES</b>			
<b>FEAT./ APP./CURVES/DIMENSIONS</b> .....	37		
<b>FEAT./ APP./CURVES/DIMENSIONS</b> .....	38		
<b>SPECIFICATIONS/DIMENSIONS</b> .....	39		
<b>CONSTRUCTIONS/APP. EXAMPLES</b> .....	40		
<b>FEATURES/APPLICATIONS</b> .....	41		
<b>PERFORMANCE CURVES (50HZ)</b> .....	42		
<b>SPECIFICATIONS/DIM. (50HZ)</b> .....	43		
<b>PERFORMANCE CURVES (60HZ)</b> .....	44		





## Determination of the required System Capacity

FIGURE 1

Description	Unit Value	Total Used
Bathroom Group, Consisting of Lavatory, Bathtub or Shower and (Direct Flush) Water Closet	10	
Bathroom Group, Consisting of Lavatory, Bathtub or Shower and (Flush Tank) Water Closet	6	
Bathtub with 1 1/2" Trap	2	
Bathtub with 2" Trap	3	
Bidet with 1 1/2" Trap	3	
Dental unit or Cuspidor	1	
Drinking Fountain	1	
Dishwasher (Domestic Type)	2	
Kitchen Sink (Domestic)	2	
Kitchen Sink (Domestic) with Waste	3	
Grinder	3	
Lavatory with 1 1/2" Trap	1	
Lavatory Barber or Beauty Shop	2	
Laundry Tray (2 compartments)	2	
Shower Stall	2	
Shower Group per head	3	
Sink (Direct Flush Valve)	7	
Sink (Service Type with Floor Drain)	3	
Sink (Scullery)	4	
Sink (Surgeons)	3	
Urinal (with Flush Valve)	8	
Urinal (with Flush Tank)	4	
Water Closet (Flush Valve)	7	
Water Closet (Flush Tank)	3	
Swimming Pools (per 1000 Gal.)	1	
Unlisted Fixture with 1 1/4" Trap	2	
Unlisted Fixture with 1 1/4" Trap	3	
Unlisted Fixture with 2" Trap	4	
Unlisted Fixture with 2 1/2" Trap	5	
Unlisted Fixture with 3" Trap	6	
Unlisted Fixture with 4" Trap	7	
Water Softener (Domestic)	4	
Washing Machine	2	
	<b>TOTAL</b>	

### SYSTEM CAPACITY

The System Capacity refers to the rate of flow in US Gallons Per Minute (US-GPM) necessary to efficiently maintain the system. The «Fixture Unit» (figure 1) method is suggested for determining this figure. This approach assigns a relative value to each fixture or group of fixtures normally encountered. Determination of the required System Capacity is as follows:

1) List all fixtures involved in the installation and using Figure 1 assign a Fixture Unit value to each. Add to obtain the total.

2) Referring to Figure 2 locate the total Fixture Unit amount along the horizontal axis of the graph and follow vertically until intersecting the plotted line. Read the System Capacity in US-GPM along the vertical axis.

FIGURE 2

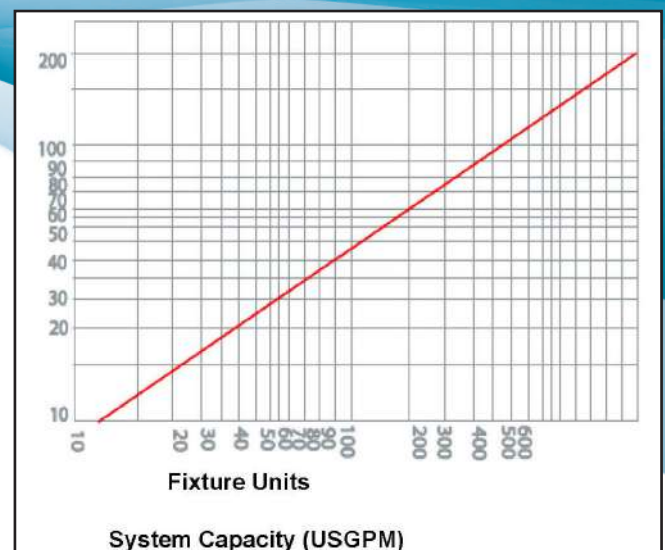



● **How to Select a Pump Model**

**1) FROM FIGURE 1**

Description	Unit Value	Total Used
Bathroom Group, Consisting of Lavatory, Bathtub or Shower and(Flush Tank)	6	24
Dishwasher (Domestic Type)	2	2
Kitchen Sink (Domestic)	2	2
Laundry Tray (2 compartments)	2	2
Shower Tall	2	2
Swimming Pools (per 1000 Gal)	1	13
Bar Sink (Unlisted with 1 1/2" T)	3	3
Water Softener (Domestic)	4	4
Washing Machine	2	2
<b>Total</b>		<b>55</b>

**EXAMPLE**  
 What Pump Capacity would be required to handle the drainage from a 4 bathroom home, also including a dishwasher, a washer, a laundry tray, a kitchen sink, a water softener, a basement shower, a 13 000 gallon pool and a bar sink with a 1 1/2" Trap?

**2) REFER TO FIGURE 2**

Find 55 Fixture Units On the horizontal axis. Follow Vertically until intersecting the plotted line then horizontally to the left. The Pump Capacity on the vertical axis is 30 USGPM.

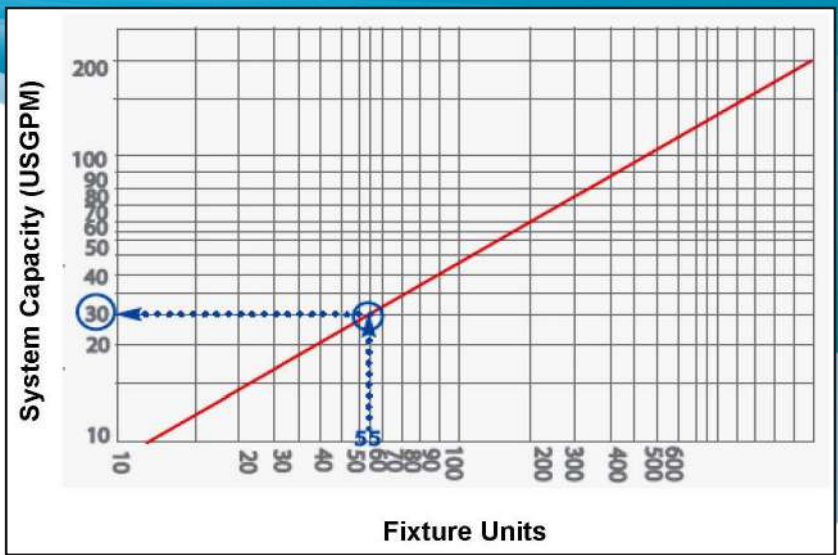

## Pumps Designed for Sewage Application and Maintenance Simplified by Automatic Connecting Device

### FEATURES

#### EPOXY Cable Sealing Base

(EPOXY) Waterproof cable prevent water infiltration, cable ends sealed with epoxy resin, and lead wires are partially tripped off for perfect resin sealing. Triple protection for the motor against water penetration.



#### Built-in Motor Protector

Every STO type are equipped with a self-reset circle thermal protector to prevent over-loading, locking of impeller, and scorch damage to the motor from phase failure.



#### SiC Mechanical Seal

Equipped with double mechanical seals and adopted with heat-and-corrosion resistant silicon carbide mechanical seal for preventing the motor from water infiltration.

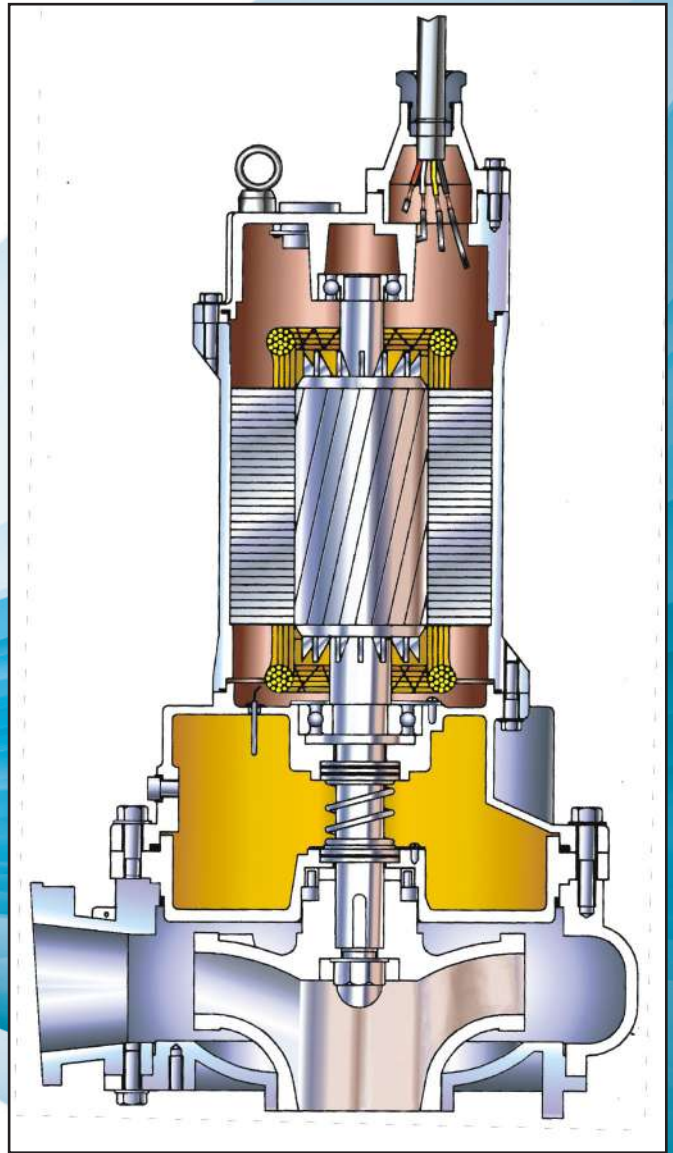

### APPLICATIONS

- Influent pumping in combined treatment plants.
- Influent pumping in industrial waste water treatment plants.
- Sewage treatment, human waste treatment.
- Sewage waste water and solid treatment in various factories and building sites.
- Pump house in sewer system.

## REFERENCE OF INSTALLATION



## MAINTENANCE SIMPLIFIED BY AUTOMATIC CONNECTING DEVICE

The automatic connecting device performs connection / disconnection between a pump and piping only by lifting the pump down / up along guide pipes, so the maintenance and inspection work can be done without entering the pump sump.









# SEWAGE PUMPS

## PICTURES OF ALL MODELS

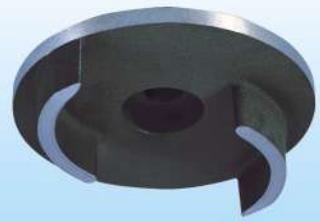
STO AUTO - SETTER TYPE SEWAGE PUMP  
 FO FLOOR MOUNT TYPE SEWAGE PUMP

<p style="text-align: center;"><b>STO</b></p> 	<p style="text-align: center;"><b>FO</b></p> 	
<p>Output : 1 - 2 HP          Motor : 2 Poles - E Insulation class          Non-clog Impeller :</p>  <p style="text-align: center;">Dual-blade semi-open type</p>	<p>Output : 3 - 5 HP          Motor : 4 Poles - B Insulation class          Non-clog Impeller :</p>  <p style="text-align: center;">Single-blade semi-open type</p>	<p>Output : 7 1/2~20 HP          Motor : 4 Poles - B Insulation class          Non-clog Impeller :</p>  <p style="text-align: center;">Dual-blade closed type</p>

STO-T AUTO - SETTER TYPE SEWAGE PUMP  
 FO-T FLOOR MOUNT TYPE SEWAGE PUMP

<p style="text-align: center;"><b>STO-T</b></p> 	<p style="text-align: center;"><b>FO-T</b></p> 	<p>Output : 1~10 HP          Motor : 2 Poles - E Insulation class          Non-clog Impeller :</p>  <p style="text-align: center;">Dual-blade semi-open type</p>
---	--	---



# SEWAGE PUMPS

## STO•STO-T Series FO•FO-T Series Sewage Pump

STO • STO-T  
FO • FO-T

AUTO - SETTER TYPE SEWAGE PUMP  
FLOOR MOUNT TYPE SEWAGE PUMP

### SPECIFICATIONS:

✓	TYPE		MOTOR								PUMP	IMPELLER		CABLE	WEIGHT(kg)		
			Power	Amp.		Volt	Phase	SS Revolution	Starting	BORE	Solid Passage	Nb of	mm <sup>2</sup> xm		Auto-setter	Floor-Mount	
	✓	Auto-setter	✓	Floor mount	KW(HP)	Start	Run	V	PH	R.P.M	method	Inch(mm)		mm			Vanes
50		STO-112		FO-112	0.75(1)			200-240	1	3000	Capacitor	2"(50)	25	2	1.25 <sup>2</sup> x6	36	30
		STO-132		FO-132		200-480	3	D.O.L									
		STO-212		FO-212	1.5(2)			200-240	1	3000	Capacitor	3"(80)	28	2	3.5 <sup>2</sup> x10	78	56
		STO-232		FO-232		200-480	3	D.O.L	74		50						
		STO-332		FO-332	2.2(3)			200-480	3	1500	D.O.L	3"(80)	40x50	1	3.5 <sup>2</sup> x10	115	97
		STO-532		FO-532	3.7(5)			200-480	3	1500	D.O.L	4"(100)	53x50	1	3.5 <sup>2</sup> x10	122	97
		STO-732		FO-732	5.5(7 1/2)			200-480	3	1500	D.O.L	4"(100)	88x46	2	5.5 <sup>2</sup> x10	177	152
		STO-1032		FO-1032	7.5(10)			200-480	3	1500	D.O.L	4"(100)	88x46	2	5.5 <sup>2</sup> x10	197	172
		STO-1532		FO-1532	11(15)			200-480	3	1500	Star-delta	6"(150)	117x48	2	5.5 <sup>2</sup> x10	302	253
		STO-2032		FO-2032	15(20)			200-480	3	1500	Star-delta	6"(150)	117x50	2	8.0 <sup>2</sup> x10	312	263
60		STO-112		FO-112	0.75(1)			200-240	1	3600	Capacitor	2"(50)	25	2	1.25 <sup>2</sup> x6	36	30
		STO-132		FO-132		200-480	3	D.O.L									
		STO-212		FO-212	1.5(2)			200-240	1	3600	Capacitor	3"(80)	28	2	3.5 <sup>2</sup> x10	78	56
		STO-232		FO-232		200-480	3	D.O.L	74		50						
		STO-332		FO-332	2.2(3)			200-480	3	1800	D.O.L	3"(80)	40x47	1	3.5 <sup>2</sup> x10	115	97
		STO-532		FO-532	3.7(5)			200-480	3	1800	D.O.L	4"(100)	53x47	1	3.5 <sup>2</sup> x10	122	97
		STO-732		FO-732	5.5(7 1/2)			200-480	3	1800	D.O.L	4"(100)	88x46	2	5.5 <sup>2</sup> x10	177	152
		STO-1032		FO-1032	7.5(10)			200-480	3	1800	D.O.L	4"(100)	88x46	2	5.5 <sup>2</sup> x10	197	172
		STO-1532		FO-1532	11(15)			200-480	3	1800	Star-delta	6"(150)	117x48	2	5.5 <sup>2</sup> x10	302	253
		STO-2032		FO-2032	15(20)			200-480	3	1800	Star-delta	6"(150)	117x50	2	8.0 <sup>2</sup> x10	312	263
50		STO-112T		FO-112T	0.75(1)			200-240	1	3000	Capacitor	2"(50)	25	2	2.0 <sup>2</sup> x6	35	30
		STO-132T		FO-132T		200-480	3	D.O.L									
		STO-212T		FO-212T	1.5(2)			200-240	1	3000	Capacitor	3"(80)	28	2	5.5 <sup>2</sup> x10	75	56
		STO-232T		FO-232T		200-480	3	D.O.L	69		50						
		STO-332T		FO-332T	2.2(3)			200-480	3	3000	D.O.L	3"(80)	28	2	5.5 <sup>2</sup> x10	78	59
		STO-532T		FO-532T	3.7(5)			200-480	3	3000	D.O.L	4"(100)	32	2	5.5 <sup>2</sup> x10	86	61
		STO-732T		FO-732T	5.5(7 1/2)			200-480	3	3000	D.O.L	4"(100)	26	2	5.5 <sup>2</sup> x10	114	90
		STO-1032T		FO-1032T	7.5(10)			200-480	3	3000	D.O.L	4"(100)	26	2	5.5 <sup>2</sup> x10	125	101





## STANDARD ACCESSORIES

### FOR STO•STO-T TYPE

- Upper Guide Support .....1 set
- Guide Connector .....1 set
- Lifting Chain (with shackle) ...1 pc
- Duck Foot Bend .....1 set

### FOR FO•FO-T TYPE

- Connecting Elbow.....1

Parts no	Discharge bore	Description	2"(50mm)	3"(80mm)	4"(100mm)	6"(150mm)	Material
126		Upper Guide Support	1.5 kg	2 kg	4.5 kg	6 kg	Cast iron
125		Guide Connector	2.7 kg	3.6 kg	4.5 kg	9.5 kg	Cast iron
97		Lifting Chain (with shackle)	4 m	4 m	4 m	4 m	Stainless steel
129		Duck Foot Bend	12 kg	30 kg	33 kg	64 kg	Cast iron
143		Connecting Elbow	...	15 kg	15 kg	30 kg	Cast iron

## STO / FO PERFORMANCE CURVE

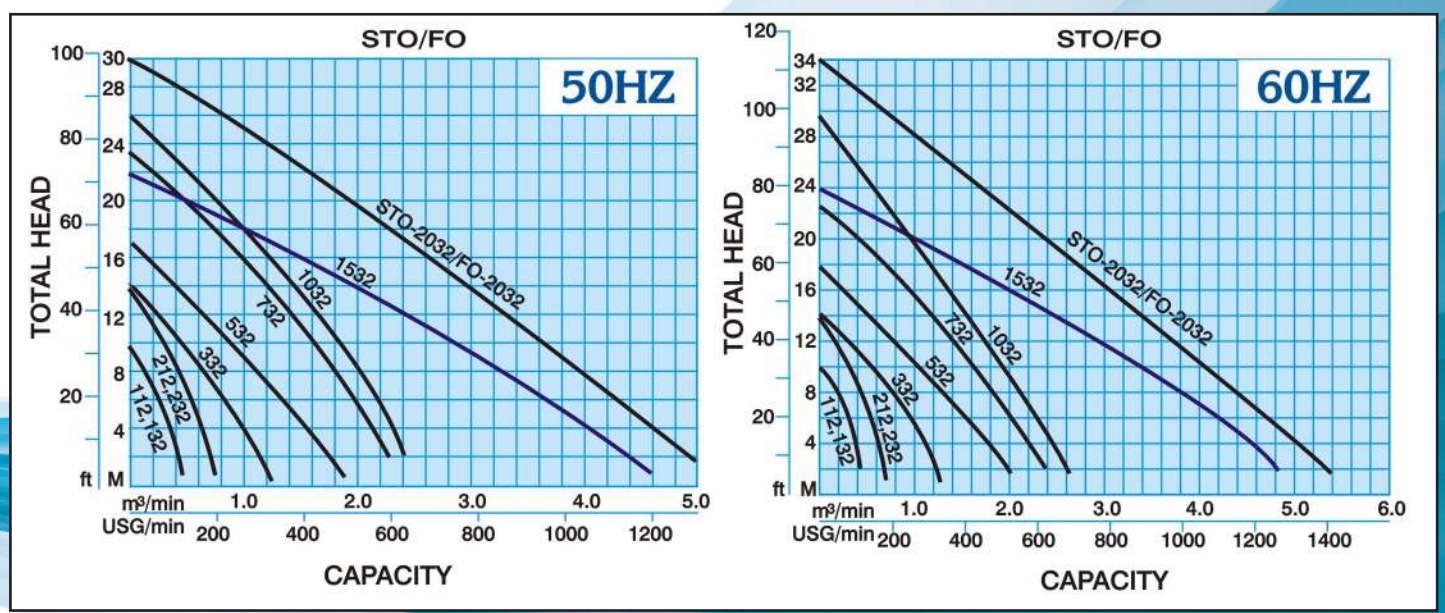

## STO-T / FO-T PERFORMANCE CURVE

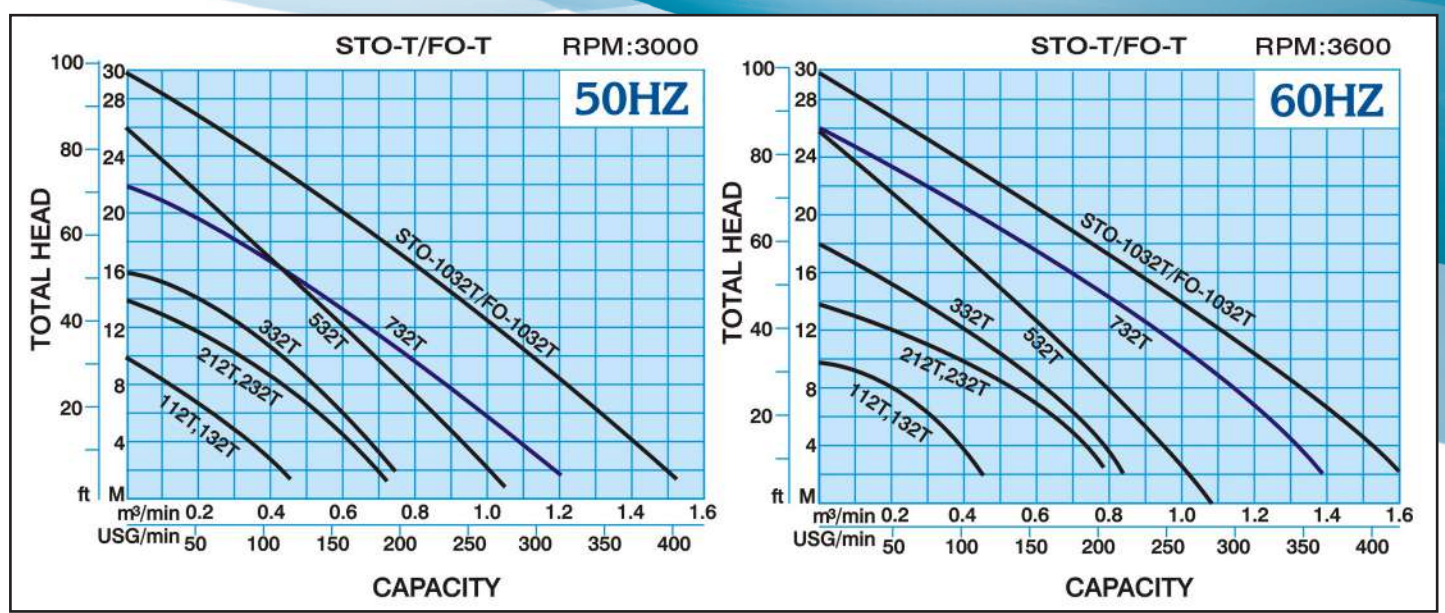



## STO DIMENSIONS

C.W.L. : Continuous running Water Level  
L.W.L. : Lowest running Water Level

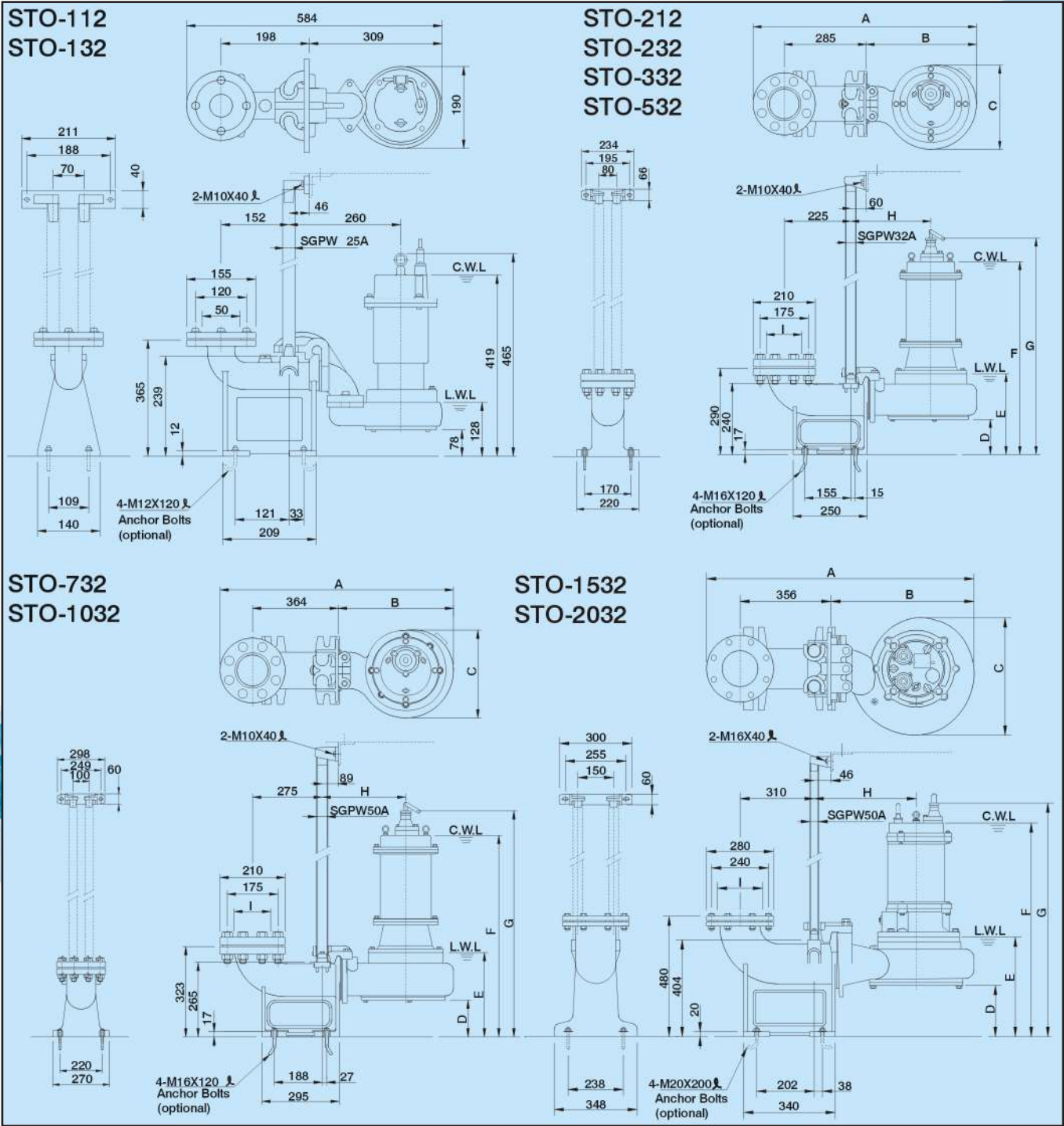

unit : mm									
TYPE	A	B	C	D	E	F	G	H	I
STO-212	693	303	212	140	217	568	618	256	ø80
STO-232	693	303	212	140	217	467	515	256	ø80
STO-332	755	365	311	116	282	633	721	270	ø80(ø100)
STO-532	755	365	311	116	282	658	746	270	ø100(ø80)
STO-732	899	430	385	116	274	721	803	330	ø100
STO-1032	899	430	385	116	274	742	824	330	ø100
STO-1532	1019	623	491	215	416	894	976	427	ø150
STO-2032	1019	623	491	215	416	924	1006	427	ø150

unit : inches									
TYPE	A	B	C	D	E	F	G	H	I
STO-212	27,72	12,12	212	8,48	8,68	22,72	24,72	10,24	ø3.2
STO-232	27,72	12,12	212	8,48	8,68	18,68	20,6	10,24	ø3.2
STO-332	30,2	14,6	311	12,44	11,28	25,32	28,84	10,8	ø3.2(ø4)
STO-532	30,2	14,6	311	12,44	11,28	26,32	29,84	10,8	ø4ø3.2
STO-732	35,96	17,2	385	15,4	10,96	28,84	32,12	13,2	ø4
STO-1032	35,96	17,2	385	15,4	10,96	29,68	32,96	13,2	ø4
STO-1532	40,76	24,92	491	19,64	16,64	35,76	39,04	17,08	ø6
STO-2032	40,76	24,92	491	19,64	16,64	36,96	40,24	17,08	ø6



## FO•FO-T DIMENSIONS

C.W.L. : Continuous running Water Level  
L.W.L. : Lowest running Water Level

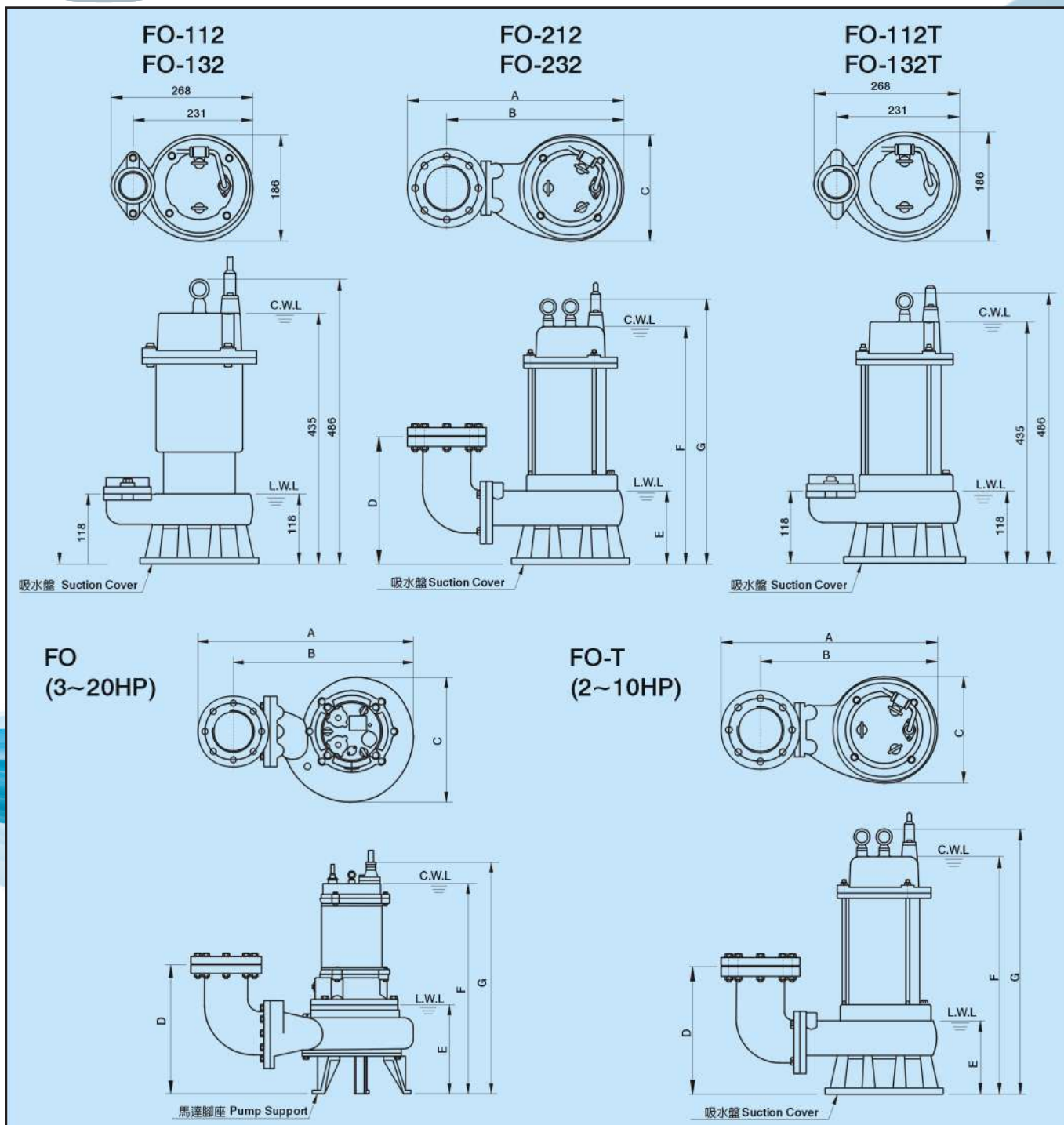

unit : mm

TYPE	A	B	C	D	E	F	G	TYPE	A	B	C	D	E	F	G
FO-212	518	413	212	265	122	473	523	FO-212T	518	413	212	265	122	473	523
FO-232	518	413	212	265	122	372	420	FO-232T	518	413	212	265	122	372	420
FO-332	580	475	311	345	276	627	715	FO-332T	518	413	212	265	122	392	449
FO-532	580	475	311	345	276	652	740	FO-532T	518	413	212	265	122	412	479
FO-732	681	576	385	365	288	715	797	FO-732T	518	413	256	267	126	492	560
FO-1032	681	576	385	365	288	736	818	FO-1032T	518	413	256	267	126	490	560
FO-1532	880	740	491	405	311	789	817								
FO-2032	880	740	491	405	311	819	901								

\*inches on  
next page





# SEWAGE PUMPS

## FO•FO-T DIMENSIONS

C.W.L. : Continuous running Water Level  
L.W.L. : Lowest running Water Level

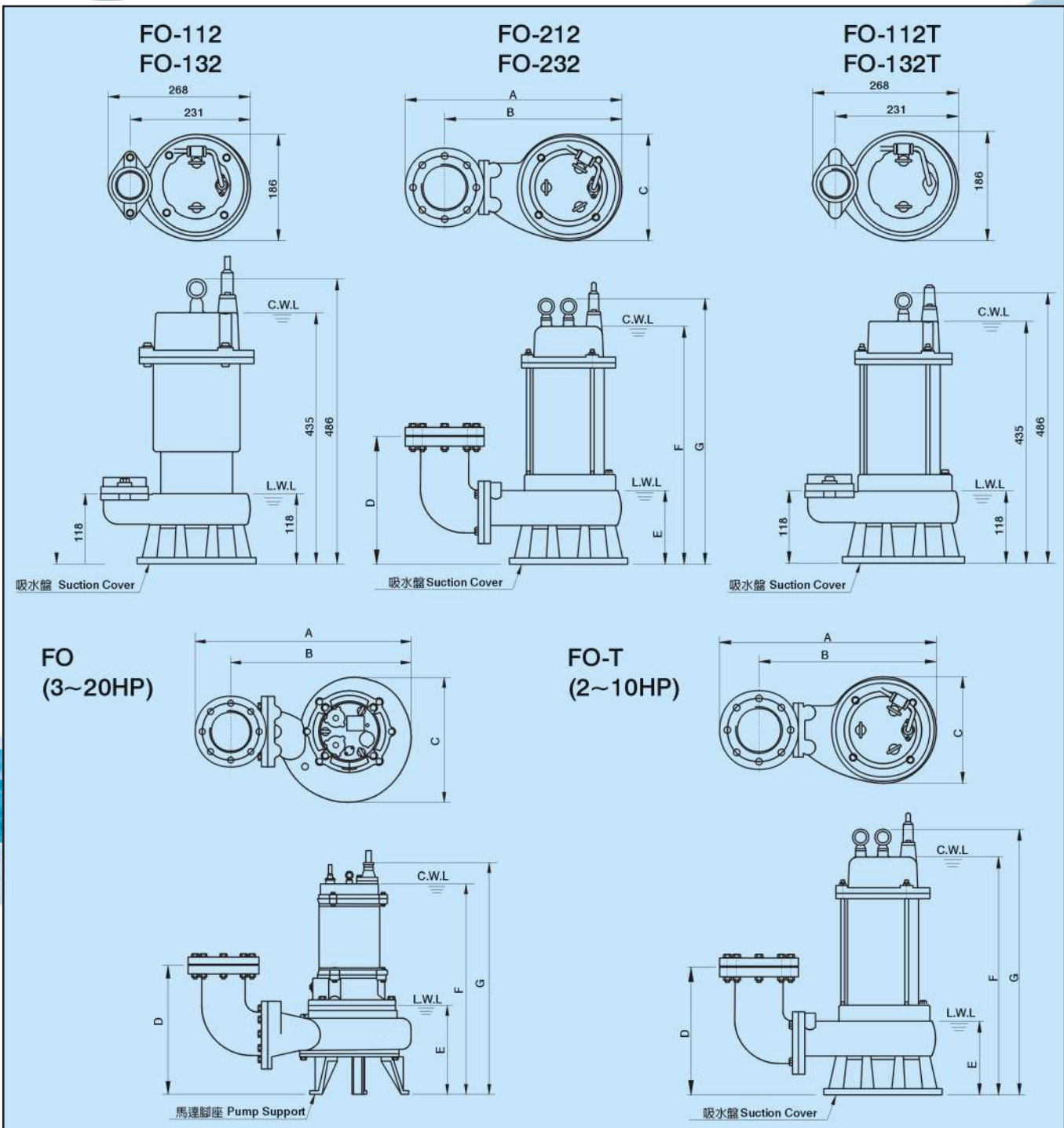

unit : inches

TYPE	A	B	C	D	E	F	G	TYPE	A	B	C	D	E	F	G
FO-212	20,72	16,52	8,48	10,6	4,88	18,92	20,92	FO-212T	20,72	16,52	8,48	10,6	4,88	18,92	20,92
FO-232	20,72	16,52	8,48	10,6	4,88	14,88	16,8	FO-232T	20,72	16,52	8,48	10,6	4,88	14,88	16,8
FO-332	23,2	19	12,44	13,8	11,04	25,08	28,6	FO-332T	20,72	16,52	8,48	10,6	4,88	15,68	17,96
FO-532	23,2	19	12,44	13,8	11,04	26,08	29,6	FO-532T	20,72	16,52	8,48	10,6	4,88	16,48	19,16
FO-732	27,24	23,04	15,4	14,6	11,52	28,6	31,88	FO-732T	20,72	16,52	10,24	10,68	5,04	19,68	22,4
FO-1032	27,24	23,04	15,4	14,6	11,52	29,44	32,72	FO-1032T	20,72	16,52	10,24	10,68	5,04	19,6	22,4
FO-1532	35,2	29,6	19,64	16,2	12,44	31,56	32,68								
FO-2032	35,2	29,6	19,64	16,2	12,44	32,76	36,04								

## STO-C / FO-C Series Cutter Pump

Pumps Designed for Sewage Application and Maintenance  
Simplified by Automatic Connecting Device

### FEATURES

#### EPOXY Cable Sealing Base

(EPOXY) Waterproof cable prevent water infiltration, cable ends sealed with epoxy resin, and lead wires are partially tripped off for perfect resin sealing. Triple protection for the motor against water penetration.



#### Built-in Motor Protector

Every STO type are equipped with a self-reset circle thermal protector to prevent over-loading, locking of impeller, and scorch damage to the motor from phase failure.



#### SiC Mechanical Seal

Equipped with double mechanical seals and adopted with heat-and-corrosion resistant silicon carbide mechanical seal for preventing the motor from water infiltration.



### CUTTER IMPELLER & SPECIAL SUCTION COVER

A sintered tungsten carbide alloy tip is brazed onto the impeller vane and the suction cover is designed have the emission shape grooves in order to minimize cutting resistance. This «cutting mechanism» ensures materials are held for shredding in order to prevent clogging in the pump, discharge pipes and valves.

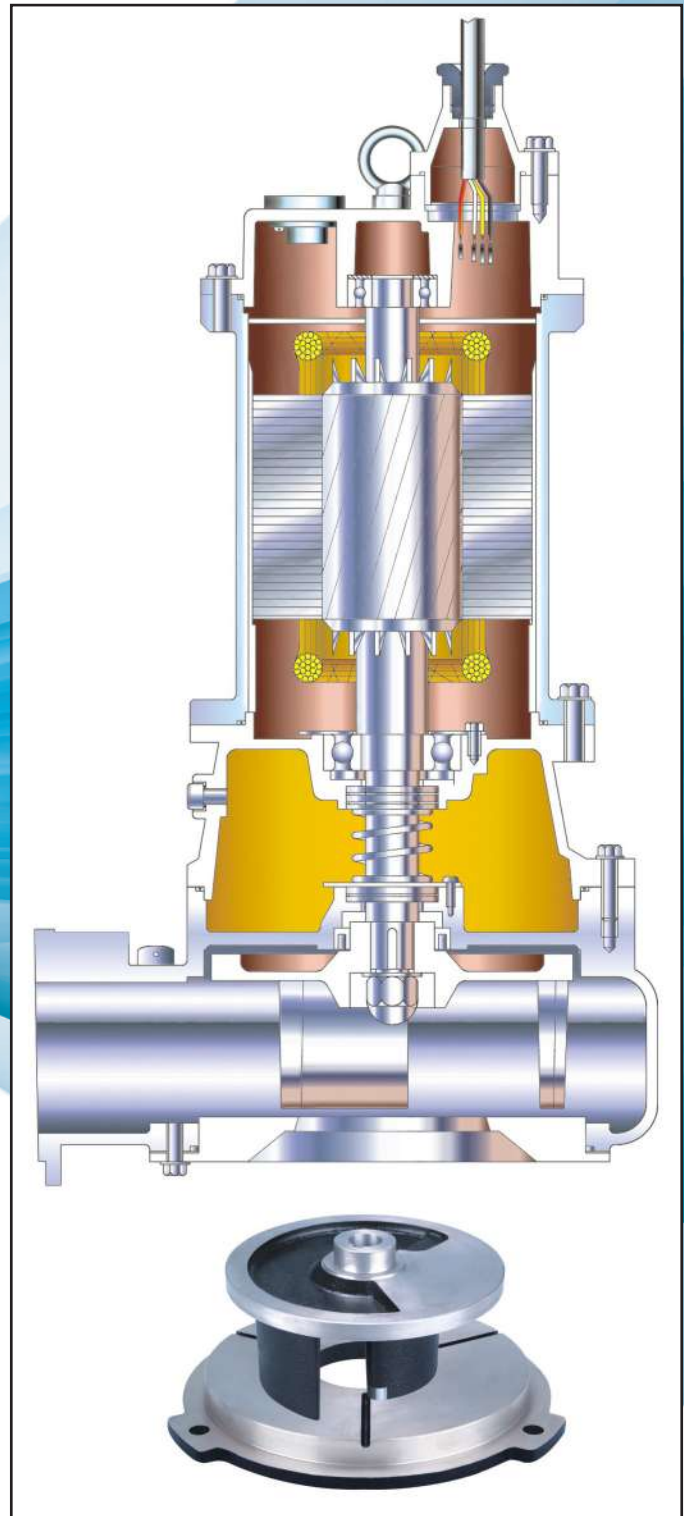

## PICTURES OF ALL MODELS

STO-C  
FO-C

AUTO - SETTER TYPE CUTTER PUMP  
FLOOR MOUNT TYPE CUTTER PUMP

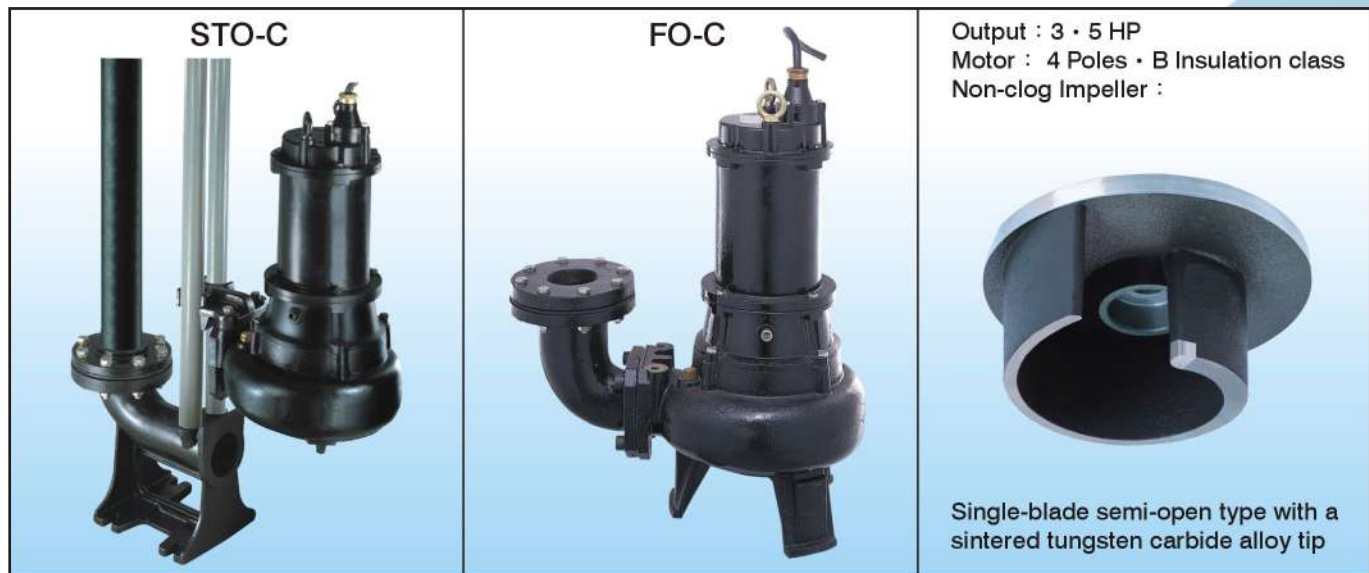

## SPECIFICATIONS:

	TYPE				MOTOR								PUMP		IMPELLER		CABLE	WEIGHT(kg)	
					Power		Amp.		Volt	Phase	SS Revolution	Starting	BORE		Solid Passage	Nb of		mm <sup>2</sup> xm	Auto-setter
	✓	Auto-setter	✓	Floor mount	KW	HP	Start	Run	V	PH	R.P.M	method	Inch	mm	mm	Vanes			
50		STO-332C		FO-332C	2.2	3			200-240	3	1500	D.O.L	3"	80	40x50	1	3.5 <sup>2</sup> x10	115	97
		STO-532C		FO-532C	3.7	5			200-480	3	1500	D.O.L	4"	100	53x50	1	3.5 <sup>2</sup> x10	122	97
60		STO-332C		FO-332C	2.2	3			200-240	3	1800	D.O.L	3"	80	40x47	1	3.5 <sup>2</sup> x10	115	97
		STO-532C		FO-532C	3.7	5			200-480	3	1800	D.O.L	4"	100	53x47	1	3.5 <sup>2</sup> x10	122	97

## STANDARD ACCESSORIES:

### FOR STO-C TYPE

- Upper Guide Support .....1 set
- Guide Connector .....1 set
- Lifting Chain (with shackle) ...1 pc
- Duck Foot Bend .....1 set

### FOR FO-C TYPE

- Connecting Elbow.....1

Parts no	Discharge bore	Description	3"(80mm)	4"(100mm)	6"(150mm)	Material
126		Upper Guide Support	2 kg	4.5 kg	6 kg	Cast iron
125		Guide Connector	3.6 kg	4.5 kg	9.5 kg	Cast iron
97		Lifting Chain (with shackle)	4 m	4 m	4 m	Stainless steel
129		Duck Foot Bend	30 kg	33 kg	64 kg	Cast iron
143		Connecting Elbow	15 kg	15 kg	30 kg	Cast iron





# CUTTER PUMPS

## STO-C/FO-C PERFORMANCE CURVES:

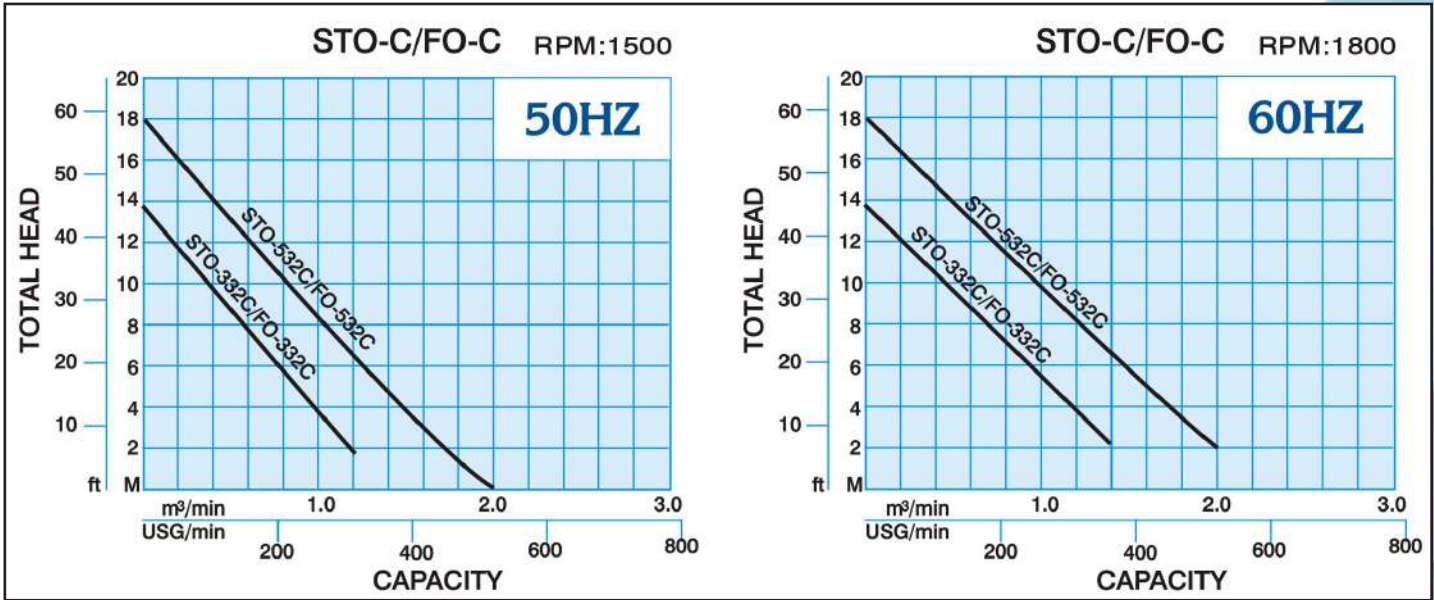

## STO-C•FO-C DIMENSIONS:

C.W.L. : Continuous running Water Level  
L.W.L. : Lowest running Water Level

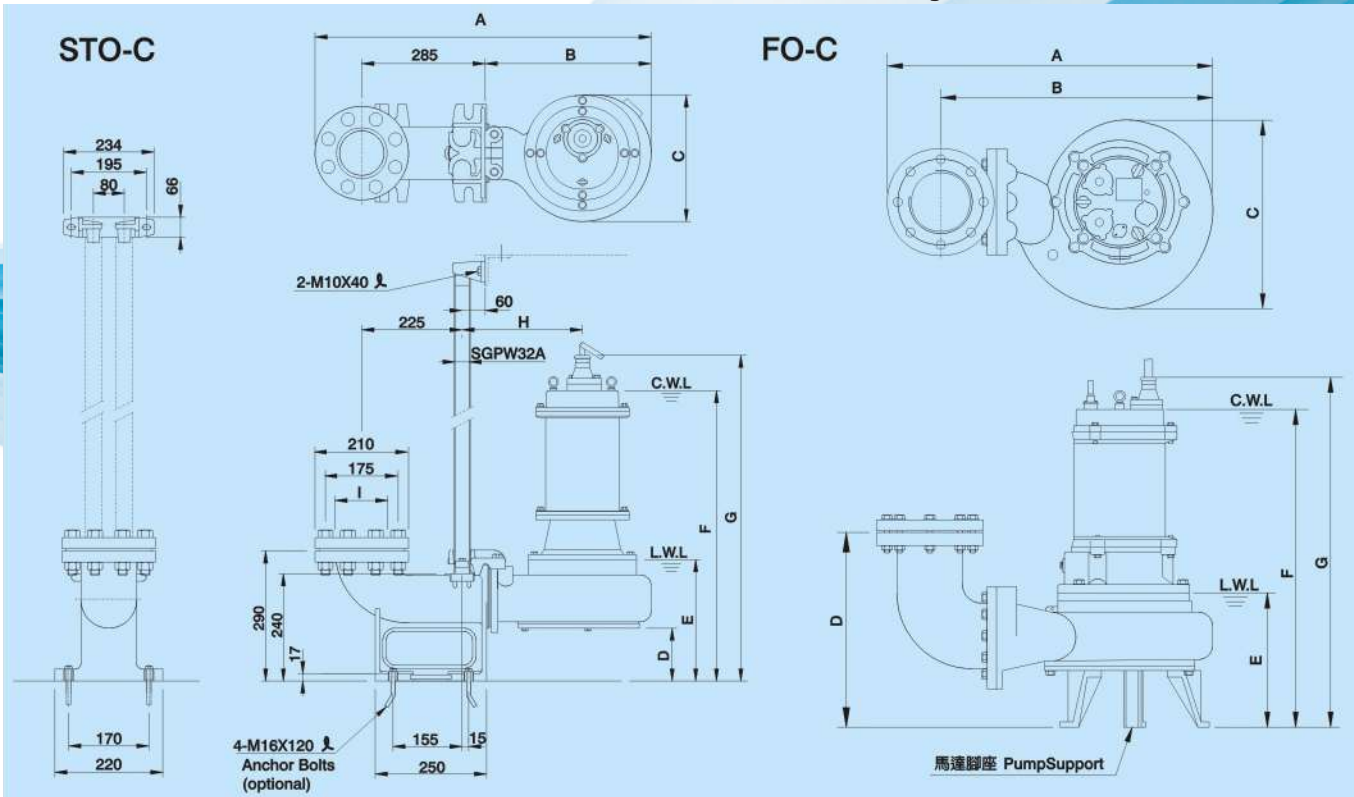

unit : mm									
TYPE	A	B	C	D	E	F	G	H	I
STO-332C	755	365	311	116	282	633	721	270	ø80(ø100)
STO-532C	755	365	311	116	282	658	746	270	ø100(ø80)
FO-332C	580	475	311	345	276	627	715	-	-
FO-532C	580	475	311	345	276	652	740	-	-

unit : inches									
TYPE	A	B	C	D	E	F	G	H	I
STO-332C	30,2	14,6	12,44	4,64	11,28	25,32	28,84	10,8	ø3.2(4)
STO-532C	30,2	14,6	12,44	4,64	11,28	26,32	29,84	10,8	ø4(3.2)
FO-332C	23,2	19	12,44	13,8	11,04	25,08	28,6	-	-
FO-532C	23,2	19	12,44	13,8	11,04	26,08	29,6	-	-

## CONSTRUCTIONS:

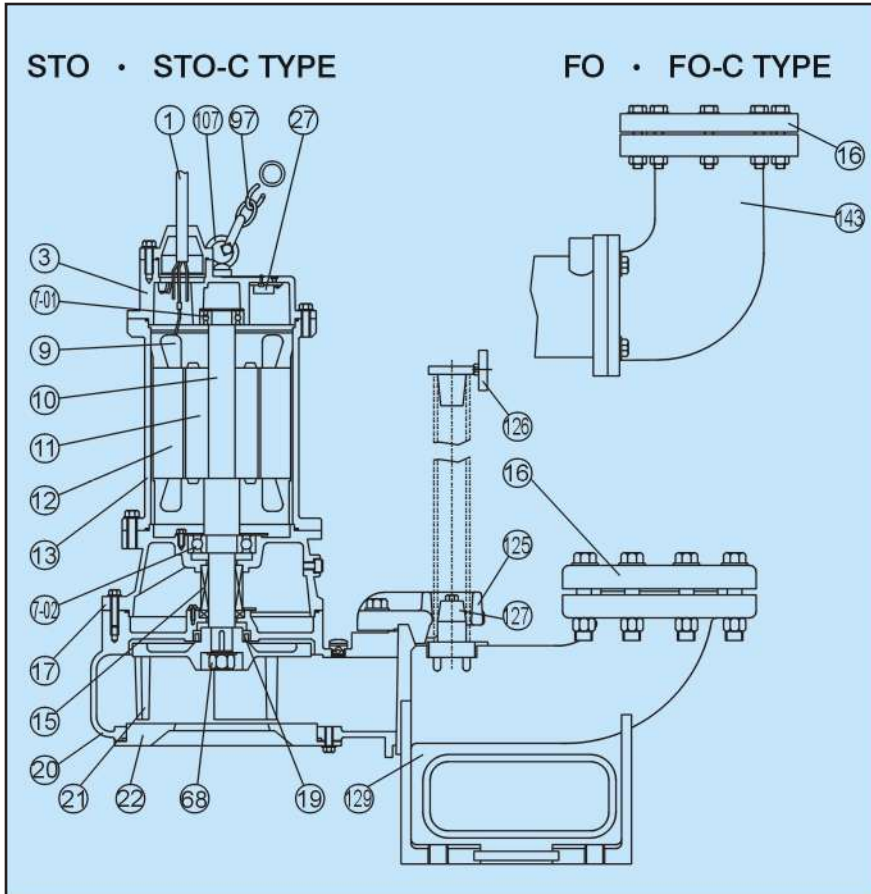

NO	NAME OF PARTS	MATERIAL
1	Cable	V.C.T
3	Motor head cover	Cast iron
7-01	Upper ball bearing	
7-02	Lower ball bearing	
9	Coil	
10	Shaft	SUS 304
11	Rotor	
12	Stator	
13	Motor casing	Cast iron
15	Mechanical seal	Silicon Carbide
16	Flange	Cast iron
17	Motor lower cover	Cast iron
19	Oil seal	
20	Pump casing	Cast iron
21	Impeller (for STO )	Cast iron
	Impeller (for STO-C ) with a sintered tungsten bide alloy tip	Cast iron
22	Suction cover	Cast iron
27	Thermal protector	
68	Nut	SUS 304
97	Lifting chain	SUS 304
107	Bolt	SUS 304
125	Guide connector	Cast iron
126	Upper guide support	Cast iron
127	Lower guide support	Cast iron
129	Duck foot bend	Cast iron
143	Connecting elbow	Cast iron

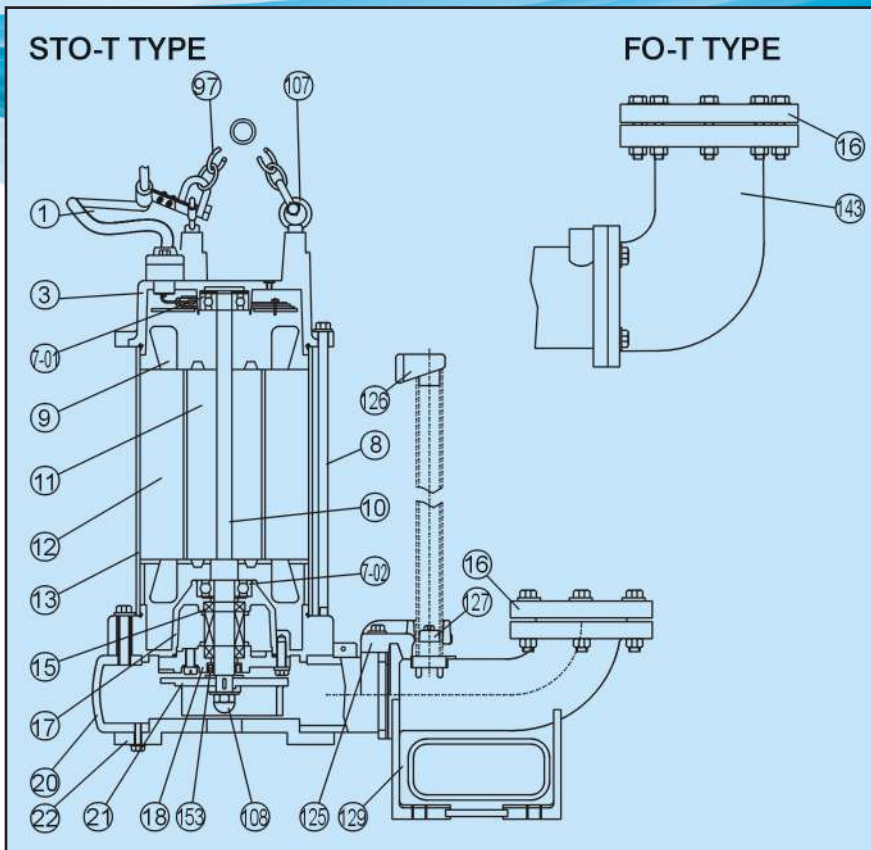

NO	NAME OF PARTS	MATERIAL
1	Cable	V.C.T
3	Motor head cover	Cast iron
7-01	Upper ball bearing	
7-02	Lower ball bearing	
8	Bolt	SUS 304
9	Coil	
10	Shaft	SUS 304
11	Rotor	
12	Stator	
13	Motor casing	SUS 304
15	Mechanical seal	Silicon Carbide
16	Flange	Cast iron
17	Motor lower cover	Cast iron
18	Mechanical seal cover	Cast iron
19	Oil seal	
20	Pump casing	Cast iron
21	Impeller (for STO )	Cast iron
22	Suction cover	Cast iron
27	Thermal protector	
97	Lifting chain	SUS 304
107	Bolt	SUS 304
108	Nut	Bronze
125	Guide connector	Cast iron
126	Upper guide support	Cast iron
127	Lower guide support	Cast iron
129	Duck foot bend	Cast iron
143	Connecting elbow	Cast iron

## FLOAT LEVEL CONTROL PANEL

-only for sewage pump use

SB1 Type : Automatic Operation for only one pump use.

SB2 Type : Automatic Alternate Operation for two pump use.

SB3 Type : Automatic Alternate & Simultaneous Operation  
for two pump use.

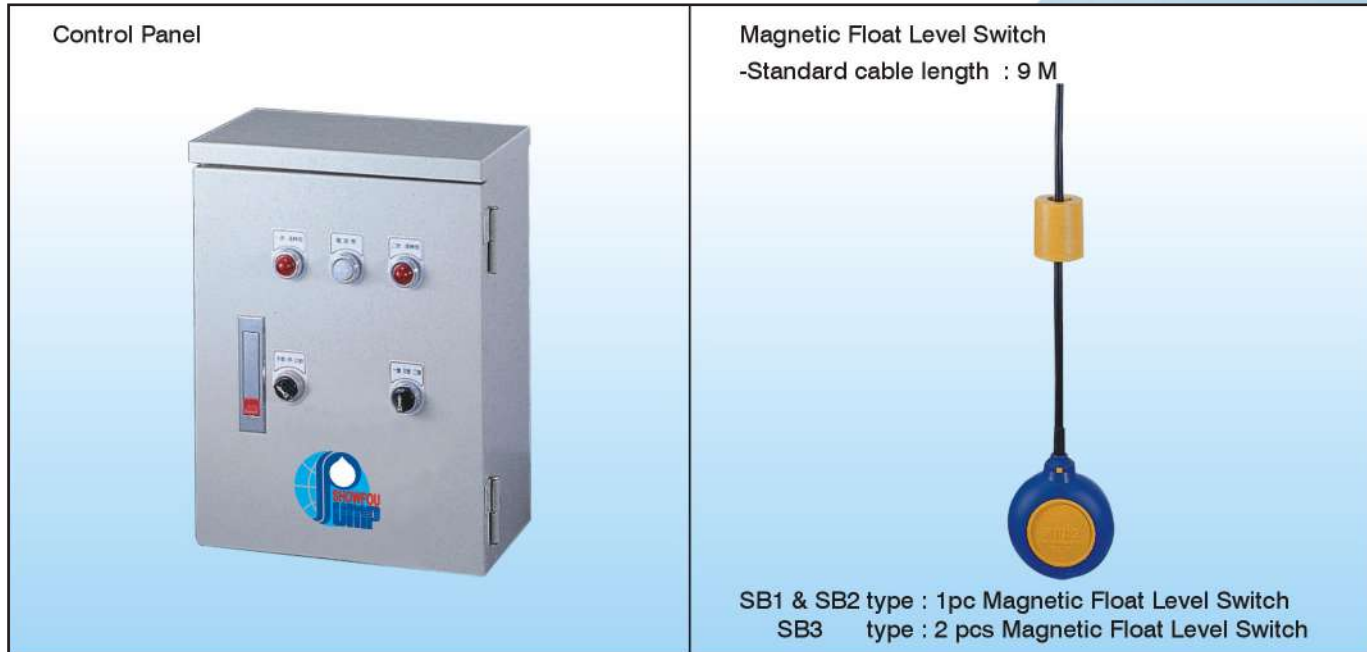

## ELECTRICAL WIRING SCHEMATIC DIAGRAM

**SB1 Type: Automatic Operation for only single pump use**

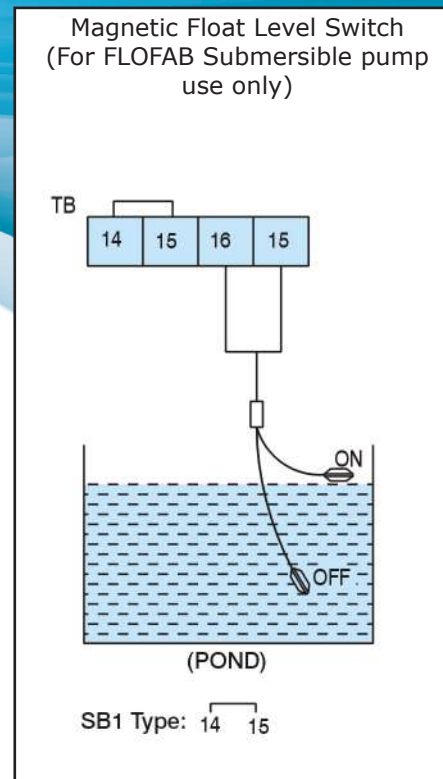
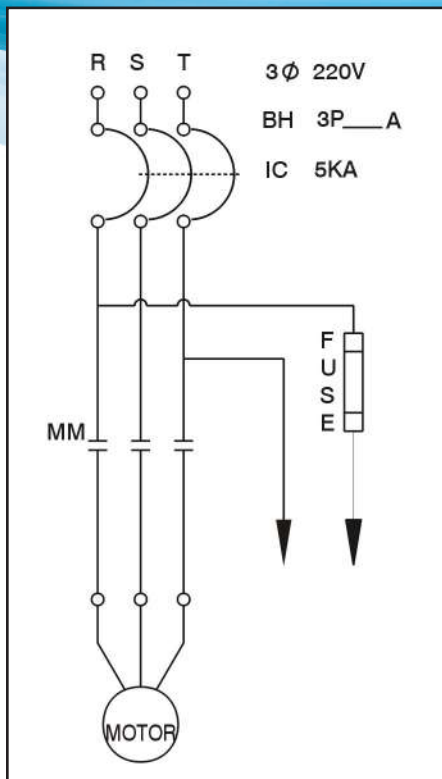





## ELECTRICAL WIRING SCHEMATIC

### SB2 Type: Automatic Operation for two pump use

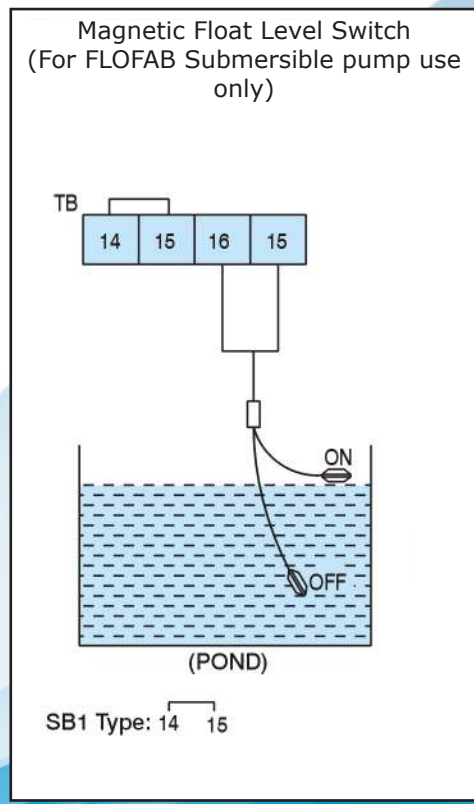
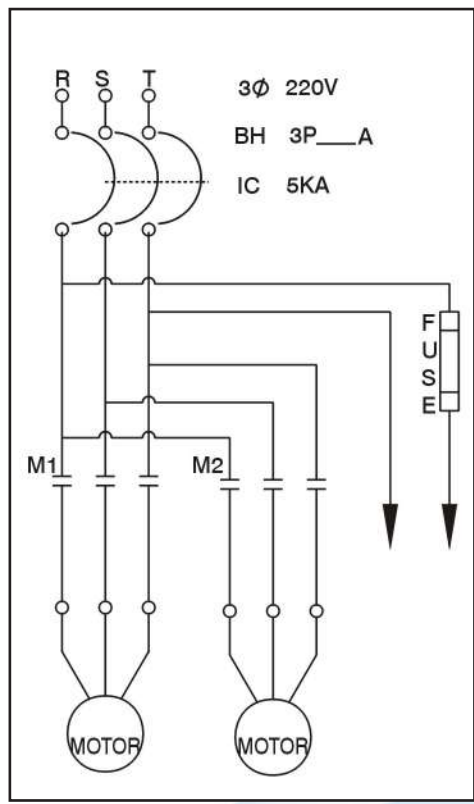

### SB3 Type: Automatic Alternate & Simultaneous Operation for two pump use.

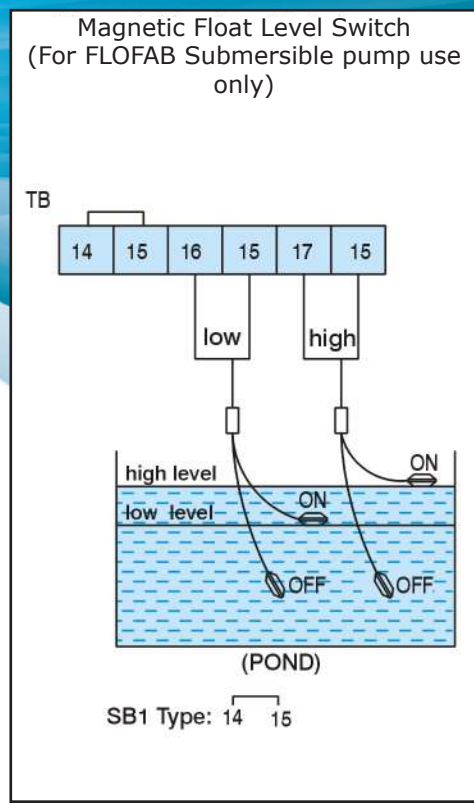
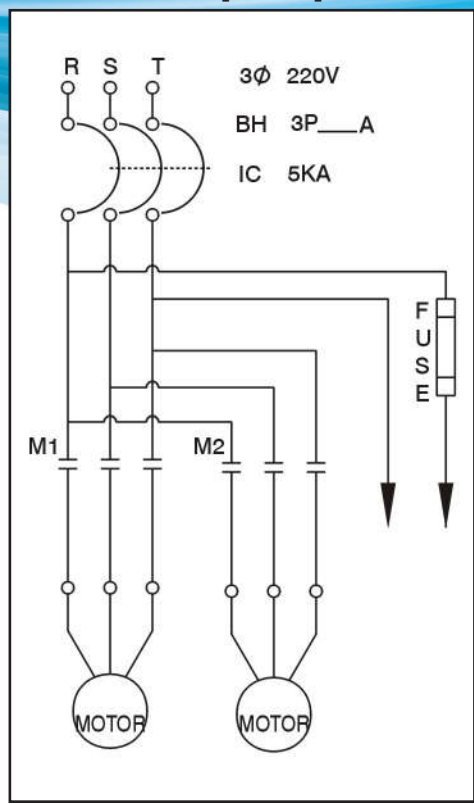

## SC Series SUBMERSIBLE DRAINAGE PUMP

## SCA Series AUTOMATIC SUBMERSIBLE DRAINAGE

### FEATURES:

- A. Motor:** Dry motor with level of protection IP 68, suitable for continuous duty.
- B. Thermal Protector:** Single phase model built-in thermal protector prevents any burning damage to the motor.
- C. Pump Casing:** Tough cast iron casing guarantees high pumping efficiency.
- D. Impeller:** Excellent durability, semi-open type impeller design, prevents clogging by mud, sand, etc.
- E. Suction Cover:** Easily replaceable.
- F. Triplex Seals:** Equipped with double mechanical seal with one oil seal.

### APPLICATION:

1. Civil engineering & construction.
2. Fountains and water features
3. Tunnel & caisson drainage.
4. Agricultural irrigation.
5. Drainage of seepage water, pumping ofrain waste water, draining of environments, bathing and swimming pools, industrial applications

### DIMENSIONS:

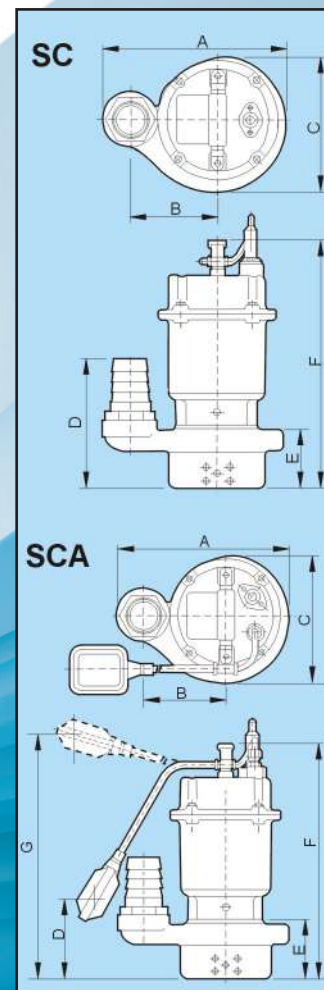

### CONSTRUCTIONS:

NO.	PARTS LIST	MATERIAL
1	Cable	V. C. T.
2	Handle	Stainless Steel
3	Motor Head Cover	Cast Iron
4	Condenser	1 $\phi$ only
6	Upper Bracket	1 $\phi$ only
7	Upper Ball Bearing	Cast Iron
9	Coil	
10	Shaft	Stainless Steel
11	Rotor	Steel Plate
12	Stator	Steel Plate
13	Motor Casing	Cast Iron
14	Hose Coupling	Plastic
15	Mechanical Seal	Ceramic-Carbon
19	Oil Seal	Synthetic Rubber
20	Pump Casing	Cast Iron
21	Impeller	Cast Iron
22	Suction Cover	Cast Iron
23	Strainer	Steel
24	Float Switch	Only for SCA

### PERFORMANCE CURVE 50Hz (RPM: 3000) / 60Hz (RPM: 3600):

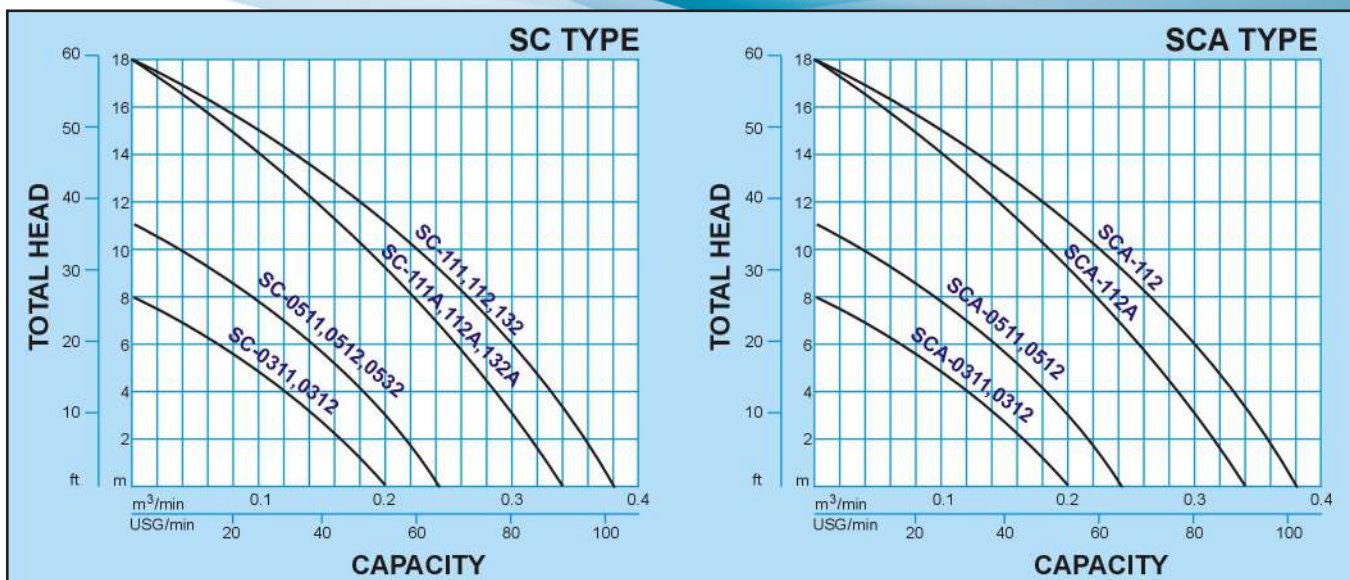



# DRAINAGE PUMPS

**SC Series** SUBMERSIBLE DRAINAGE PUMP  
**SCA Series** AUTOMATIC SUBMERSIBLE DRAINAGE

## SPECIFICATIONS:

## DIMENSIONS (MM):

✓	TYPE	MOTOR			PUMP		Cable	Weight	Spherical Solid Handling	SIZE							
		Power		Phase	Volt	Disch. Diam.				A	B	C	D	E	F	G	
		KW	HP	PH	V	mm				in	mm	mm	mm	mm	mm	mm	mm
<b>DRAINAGE PUMP</b>																	
	SC-0311	0.25	1/3	1	110	40	1/2	1.25 <sup>2</sup> x6	9	7	225	110	170	163	80	350	
	SC-0312				220												
	SC-0511	0.4	1/2	1	110	50	2	1.25 <sup>2</sup> x6	11	7	255	120	190	165	85	410	
	SC-0512				220												
	SC-0532			3	220-440												
	SC-111A	0.75	1	1	110	50	2	2 <sup>2</sup> x6	21	7	255	120	190	165	85	430	
	SC-112A				220			1.25 <sup>2</sup> x6									
	SC-132A			3	220-440												
	SC-111	0.75	1	1	110	80	3	2 <sup>2</sup> x6	24	7	310	125	210	225	95	430	
	SC-112				220			1.25 <sup>2</sup> x6									
	SC-132			3	220-440												
<b>AUTOMATIC DRAINAGE PUMP</b>																	
	SCA-0311	0.25	1/3	1	110	40	1/2	1.25 <sup>2</sup> x6	9	7	225	110	170	85	80	350	400
	SCA-0312				220												
	SCA-0511	0.4	1/2	1	110	50	2	1.25 <sup>2</sup> x6	11	7	255	120	190	90	85	410	450
	SCA-0512				220												
	SCA-112A	0.75	1	1	220	50	2	1.25 <sup>2</sup> x6	21	7	255	120	190	90	85	430	480
	SCA-112				220												

## AMPS :

TYPE	60Hz/1Ph		60Hz/3Ph			
	110V	220V	208V	230V	460V	575V
	Amp	Amp	Amp	Amp	Amp	Amp
<b>DRAINAGE PUMP</b>						
SC-0311	6					
SC-0312		3				
SC-0512		4				
SC-112A		7				
SC-132A			3.7	3.5	2	1.3
SC-112		7				
SC-132			3.7	3.5	2	1.3
<b>AUTOMATIC DRAINAGE PUMP</b>						
SCA-0311	6					
SCA-0312		3				
SCA-112A		7				
SCA-112		7				

## DIMENSIONS (IN):

TYPE	SIZE						
	A	B	C	D	E	F	G
	mm	mm	mm	mm	mm	mm	mm
<b>DRAINAGE PUMP</b>							
SC-0311	9	4.4	6.8	6.52	3.2	14	
SC-0312							
SC-0511	10.2	4.8	7.6	6.6	3.4	16.4	
SC-0512							
SC-0532							
SC-111A	10.2	4.8	7.6	6.6	3.4	17.2	
SC-112A							
SC-132A							
SC-111	12.4	5	8.4	9	3.8	17.2	
SC-112							
SC-132							
<b>AUTOMATIC DRAINAGE PUMP</b>							
SCA-0311	9	4.4	6.8	3.4	3.2	14	16
SCA-0312							
SCA-0511	10.2	4.8	7.6	3.6	3.4	16.4	18
SCA-0512							
SCA-112A	10.2	4.8	7.6	3.6	3.4	17.2	19.2
SCA-112	12.4	6.2	8.4	4	3.8	17.2	19.2





# DRAINAGE PUMPS

## SF Series SUBMERSIBLE DRAINAGE PUMP SFA Series AUTOMATIC SUBMERSIBLE DRAINAGE

### FEATURES:

1. Mini size light-weight, best quality among similar type.
2. The housing of motor and screws are manufactured with stainless steel.
3. The pumping performance is better, electricity-saving. The water volume is large and its usage and maintenance are very convenient.
4. Supplied with float level switch in the Automatic version - SFA type.

### APPLICATION:

1. Civil engineering & construction.
2. Fountains and water features
3. Tunnel & caisson drainage.
4. Agricultural irrigation.
5. Drainage of seepage water, pumping of rain waste water, draining of environments, bathing, and swimming pools, industrial applications

### DIMENSIONS:

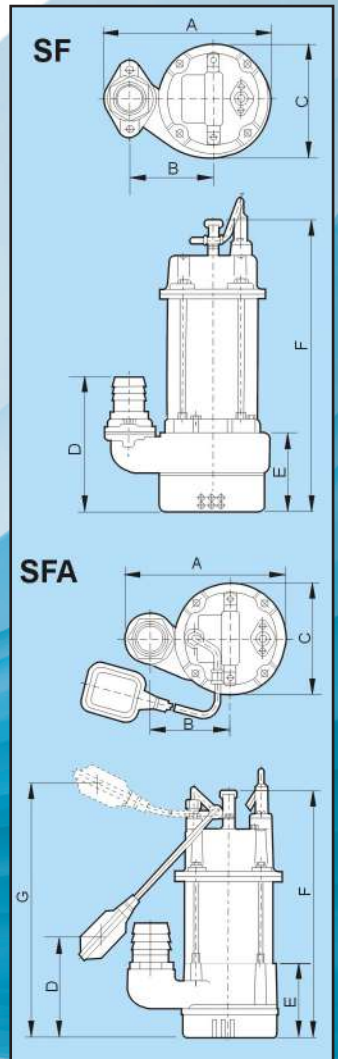

### CONSTRUCTIONS:

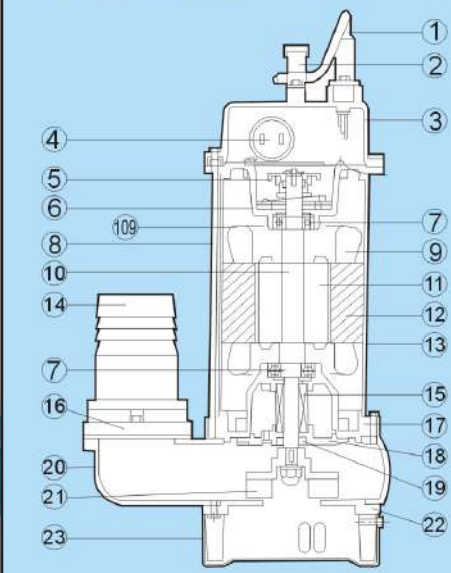

NO.	PARTS LIST	MATERIAL
1	Cable	V. C. T.
2	Handle	Stainless Steel(1/2~3HP)
3	Motor Head Cover	Cast Iron
4	Condenser	1φ only
5	Centrifugal Switch	1φ only
6	Upper Bracket	Cast Iron
7	Upper Ball Bearing	
8	Bolt	Stainless Steel
9	Coil	
10	Shaft	Stainless Steel
11	Rotor	Steel Plate
12	Stator	Steel Plate
13	Motor Casing	Stainless Steel
14	Hose Coupling	Plastic & Cast Iron
15	Mechanical Seal	Ceramic-Carbon
16	Flange Setter	Cast Iron
17	Motor Lower Cover	Cast Iron
18	Mechanical Seal Cover	Plastic / Cast Iron
19	Oil Seal	Synthetic Rubber
20	Pump Casing	Cast Iron
21	Impeller	Cast Iron / Bronze
22	Suction Cover	Cast Iron
23	Strainer	Plastic (1/3HP& 1/2HP) Stainless Steel (1~3HP)
24	Float Switch	Only for SFA

### PERFORMANCE CURVE 50Hz (RPM: 3000) / 60Hz (RPM: 3600):

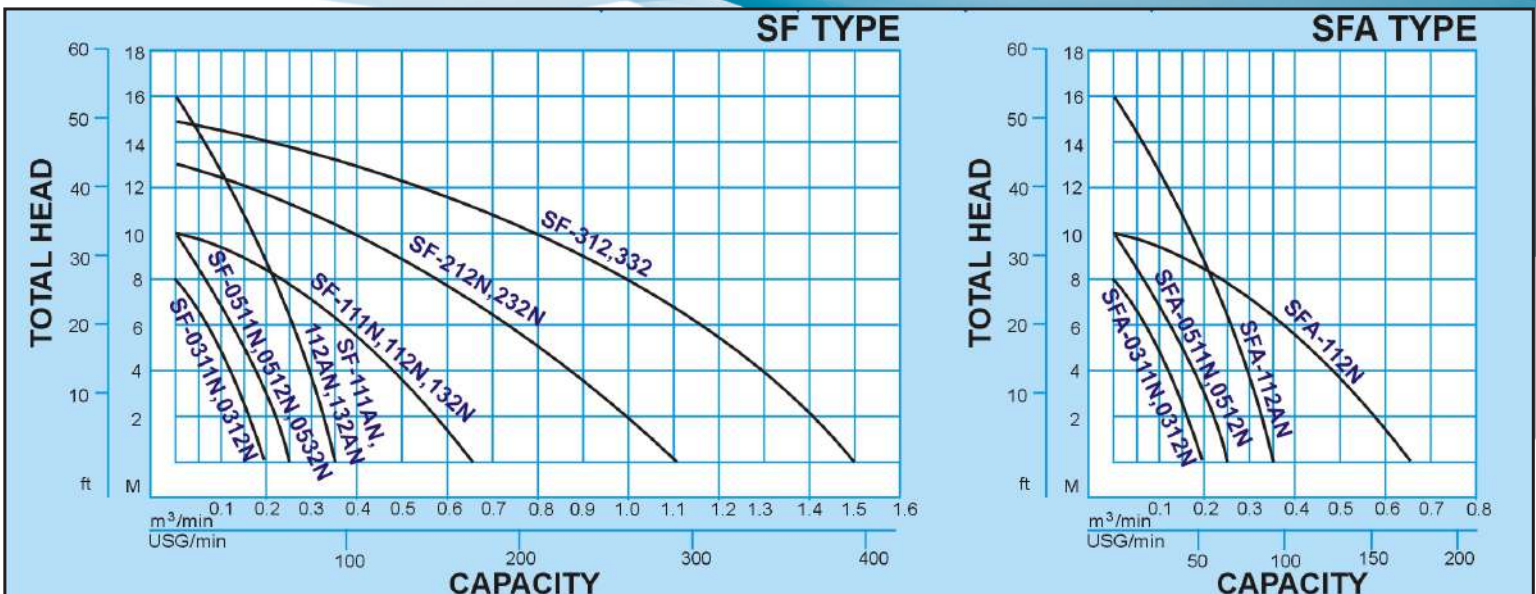



# DRAINAGE PUMPS

**SF Series** SUBMERSIBLE DRAINAGE PUMP  
**SFA Series** AUTOMATIC SUBMERSIBLE DRAINAGE

## SPECIFICATIONS:

## DIMENSIONS (MM):

✓	TYPE	MOTOR				PUMP		Cable	Weight	Spherical Solid Handling	SIZE								
		Power		Amp.		Phase	Volt				Disch. Diam.	A	B	C	D	E	F	G	
		KW	HP	Start	Run														PH
<b>DRAINAGE PUMP</b>																			
	SF-0311N	0.25	1/3			1	110	40	1/2	1.25 <sup>2</sup> x6	9	4	200	100	140	155	75	340	
	SF-0312N			220															
	SF-0511N	0.4	1/2			1	110	50	2	1.25 <sup>2</sup> x6	11	4	215	120	155	161	80	355	
	SF-0512N			220															
	SF-0532N			220-440															
	SF-111AN	0.75	1			1	110	50	2	2 <sup>2</sup> x6	21	6	265	130	190	180	85	460	
	SF-112AN			220															
	SF-132AN			220-440															
	SF-111N	0.75	1			1	110	80	3	2 <sup>2</sup> x6	24	6	300	150	190	240	125	505	
	SF-112N			220															
	SF-132N			220-440															
	SF-212N	1.5	2			1	220	100	4	3.5 <sup>2</sup> x10	35	9	385	192	225	280	130	545	
	SF-232N			220-240															
	SF-312	2.2	3			1	220	125	5	3.5 <sup>2</sup> x10	48	9	410	200	240	300	140	585	
	SF-332			220-240															
<b>AUTOMATIC DRAINAGE PUMP</b>																			
	SFA-0311N	0.25	1/3			1	110	40	1/2	1.25 <sup>2</sup> x6	9	4	200	100	140	80	75	340	425
	SFA-0312N			220															
	SFA-0511N	0.4	1/2			1	110	50	2	1.25 <sup>2</sup> x6	11	4	235	120	155	85	80	355	450
	SFA-0512N			220															
	SFA-112AN	0.75	1			1	220	50	2	2 <sup>2</sup> x6	21	6	265	130	190	90	85	460	500
	SFA-112N			220	80		3												

## DIMENSIONS (IN):

TYPE	SIZE						
	A	B	C	D	E	F	G
	in	in	in	in	in	in	in
<b>DRAINAGE PUMP</b>							
SF-0311N	8	4	5.6	6.2	3	13.6	
SF-0312N							
SF-0511N	8.6	4.8	6.2	6.44	3.2	14.2	
SF-0512N							
SF-0532N							
SF-111AN	10.6	5.2	7.6	7.2	3.4	18.4	
SF-112AN							
SF-132AN							
SF-111N	12	6	7.6	9.6	5	20.2	
SF-112N							
SF-132N							
SF-212N	15.4	7.68	9	11.2	5.2	21.8	
SF-232N	15.4	7.68	9	11.2	5.2	17.6	
SF-312	16.4	8	9.6	12	5.6	23.4	
SF-332	16.4	8	9.6	12	5.6	19.4	
<b>AUTOMATIC DRAINAGE PUMP</b>							
SFA-0311N	8	4	5.6	3.2	3	13.6	17
SFA-0312N							
SFA-0511N	9.4	4.8	6.2	3.4	3.2	14.2	18
SFA-0512N							
SFA-112AN	10.6	5.2	7.6	3.6	3.4	18.4	20
SFA-112N	12	6	7.6	4	5	20.2	22



## SC-112A

MOTOR	(Hz)	(HP)	(V)	(PH)	(A)	(P)	RPM	PUMP	(mm)	(in)
	60	1	220	1	7	2	3600		50	2

	m3/m	m	V	A	Pin (KW)	BHP (KW)	WHP (KW)	%
1	0.37	2.0	220	6.4	1.12	0.75	0.12	16.1
2	0.25	9.4	220	5.7	0.99	0.66	0.38	57.7
3	0.21	11.7	220	5.6	0.98	0.66	0.40	61.0
4	0.20	12.0	220	5.5	0.97	0.65	0.39	60.4
5	0.18	12.7	220	5.4	0.94	0.63	0.37	59.2
6	0.00	18.0	220	4.2	0.76	0.51	0.00	0.0



Advanced «Shredder Mechanism»

Unique «Epoxy Cable Seating Base» to ensure 100% capability to block the water vapor into the motor from outside.

Triplex Seal System - Double Mechanical Seal plus OH Seal

#### FEATURES:

##### \* Impeller :

hydrodynamically well-balanced dual blade semi-open non-clogging type.

##### \* Mechanical Seal :

Oil-bath type, double mechanical seal & oil seal offers which ensure a longer pump life.

##### \* Shredder Mechanism :

Surface hardening heat treatment is done on impeller vanes and cutting edges on impeller cover, both of which are the main components of shredder mechanism.

##### \* Compact and Light-Weight :

Designed to be light so easy to carry and handle.

##### \* Quiet :

Dynamic balance adjuster enables pump to run balanced with less noise in addition to underwater operation.

##### \* Economical :

Long-runable with less maintenance cost.

#### APPLICATION:

Ideal for sewage, industrial & ground water drainage installation in the following fields.

- # Sewage pumping stations.
- # Sewage treatment plants.
- # Septic tanks.

- # Collecting & settling sumps
- # Flood & emergency.

- # Anywhere drainage of dirty water with rags mixed in.

##### \* Residential Sites

- # Residential houses
- # Small groups of houses
- # Flats & apartment

##### \* Commercial Sites

- # Restaurants & shops
- # Markets & supermarkets
- # Hospitals
- # Laundries

- # Stations
- # Theaters

- # Garages

##### \* Industrial Sites

- # Mills & factories, for pumping slurry, sludge, viscous & dirty water arised during processes.

##### Industrial buildings.

- # Sewage treatment plants.
- # Water purification plants

#### CONSTRUCTIONS:

##### SS/SSA/SST/STA/SSM/SMA

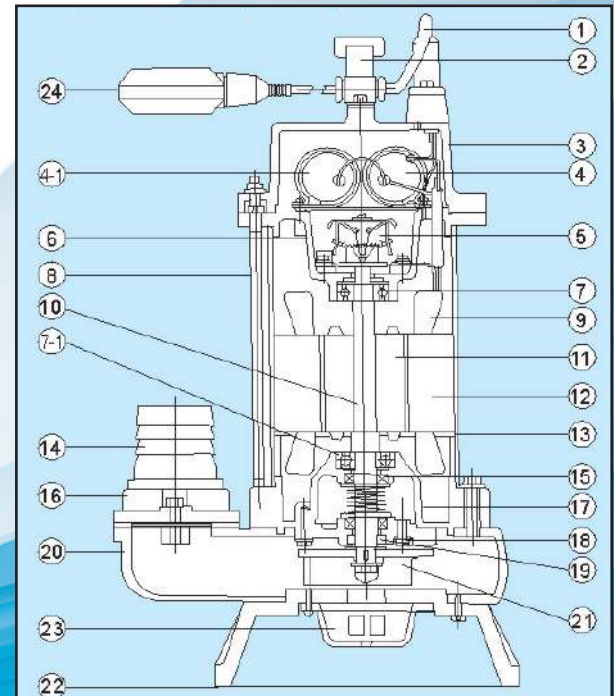

NO.	PARTS LIST	MATERIAL
1	Cable	VCT
2	Handle	Stainless Steel
3	Motor Head Cover	Cast Iron
4	Running Capacitor	MF
4-1	Starting Capacitor	MFD
5	Centrifugal Switch	
6	Upper Bracket	Cast Iron
7	Upper Ball Bearing	
7-1	Lower Ball Bearing	
8	Bolt	Stainless Steel
9	Coil	
10	Shaft	Carbon Steel Stainless Steel
11	Rotor	Steel Plate
12	Stator	Steel Plate
13	Motor Casing	Stainless Steel
14	Hose Coupling	Plastic/Cast Iron
15	Mechanical Seal	Ceramic Carbon(SS/SSA/SSM/SMA) Silicon Carbide(SST/STA)
16	Flange Setter	Cast Iron
17	Motor Lower Cover	Cast Iron
18	Mechanical Seal Cover	Cast Iron
19	Oil Seal	Synthetic Rubber
20	Pump Casing	Cast Iron
21	Impeller	Cast Iron
22	Suction Cover	Cast Iron
23	Strainer	Plastic
24	Floating Switch	SSA/STA/SMA

#### Shredder Mechanism:

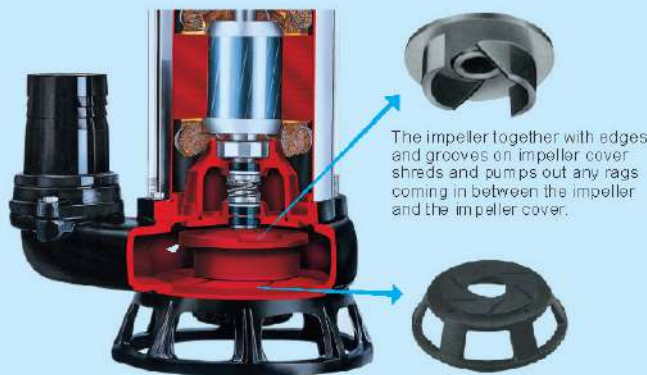

The impeller together with edges and grooves on impeller cover shreds and pumps out any rags coming in between the impeller and the impeller cover.

The cutting blades are designed to have the specific and spiral curves in order to minimize cutting resistance. Surface hardening heat treatment is done on edges.

Hydrodynamically well-balanced dual blade impeller is mounted.



# DRAINAGE PUMPS

## SS / SSA / ST / STA Series

### Vortex Sewage Pump

#### PERFORMANCE CURVES:

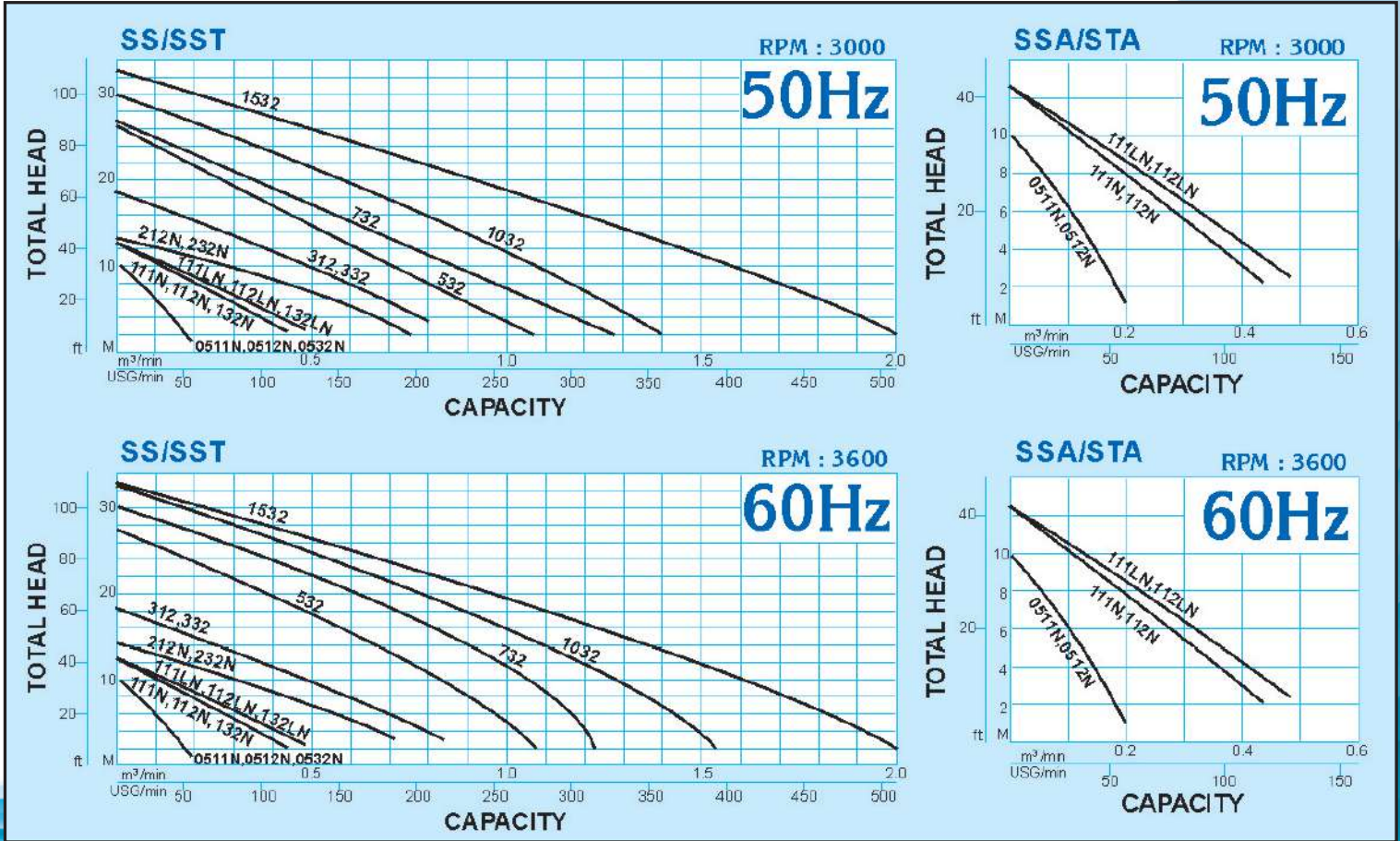

#### DIMENSIONS:

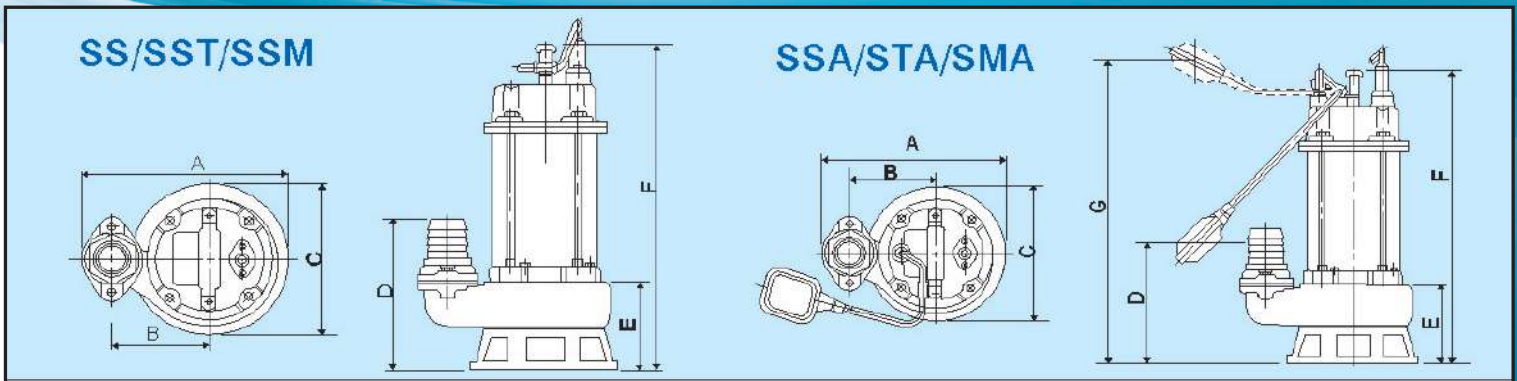





# DRAINAGE PUMPS

## SS / SSA / ST / STA Series Vortex Sewage Pump

### SPECIFICATIONS:

### DIMENSIONS (MM):

TYPE		MOTOR				Disch. Diam.	Solid Passage	Cable	Weight	SIZE									
		Power		Amp.						Phase	Volt	A	B	C	D	E	F	G	
✓	✓	HP	KW	Start	Run	PH	V	in	mm	mm	mm <sup>2</sup> xM	KG	mm	mm	mm	mm	mm	mm	mm
<b>SS</b>	<b>SST</b>	<b>SS/SST : Manual Type</b>				<b>SS(With Ceramic Carbon Seal)</b>				<b>SST(With Silicon carbide Seal)</b>									
SS-0511N		1/2	0.4			1	110	2	0.20	14	1.25 <sup>2</sup> x6	11	230	102	180	165	85	350	
SS-0512N							220												
SS-0532N							200-480												
SS-111N	SST-111N	1	0.75			1	110	2	0.50	25	2 <sup>2</sup> x6	22	290	135	225	205	115	470	
SS-112N	SST-112N						220												
SS-132N	SST-132N						200-480												
SS-111LN	SST-111LN	1	0.75			1	110	3	0.60	25	2 <sup>2</sup> x6	24	320	150	225	240	117	470	
SS-112LN	SST-112LN						220												
SS-132LN	SST-132LN						200-480												
SS-212N	SST-212N	2	1.5			1	200-480	3	0.80	28	3.5 <sup>2</sup> x10	36	355	165	265	260	140	550	
SS-232N	SST-232N						200-480												
SS-312	SST-312	3	2.2			1	200-480	4	0.90	28	3.5 <sup>2</sup> x10	53	410	192	265	290	140	580	
SS-332	SST-332						200-480												
SS-532	SST-532	5	3.7			3	200-480	4	1.06	32	3.5 <sup>2</sup> x10	49	410	192	265	290	140	500	
SS-732	SST-732	7 1/2	5.5			3	200-480	4	1.38	26	5.5 <sup>2</sup> x10	77	435	210	280	300	150	615	
SS-1032	SST-1032	10	7.5			3	200-480	4	1.50	26	5.5 <sup>2</sup> x10	88	435	210	280	300	150	615	
SS-1532	SST-1532	15	11			3	200-480	4	2.20	30	8 <sup>2</sup> x10	120	460	218	306	350	193	692	
<b>SSA</b>	<b>STA</b>	<b>SSA/STA : Automatic Type</b>				<b>SSA (With Ceramic Carbon Seal)</b>				<b>STA(With Silicon carbide Seal)</b>									
SSA-0511N		1/2	0.4			1	110	2	0.20	14	1.25 <sup>2</sup> x6	11.18	230	102	180	110	85	390	320
SSA-0512N							220												
SSA-111N	STA-111N	1	0.75			1	110	2	0.52	25	2 <sup>2</sup> x6	22	290	135	225	130	115	470	590
SSA-112N	STA-112N						220												
SSA-111LN	STA-111LN	1	0.75			1	110	3	0.60	25	2 <sup>2</sup> x6	24	320	150	225	130	117	470	590
SSA-112LN	STA-112LN						220												

### DIMENSIONS (IN):

TYPE	SIZE						
	A	B	C	D	E	F	G
mm	mm	mm	mm	mm	mm	mm	mm
<b>SS</b>							
SS-0511N	9,2	4,08	7,2	6,6	3,4	14	
SS-0512N							
SS-0532N							
SS-111N	11,6	5,4	9	8,2	4,6	18,8	
SS-112N							
SS-132N							
SS-111LN	12,8	6	9	9,6	4,68	18,8	
SS-112LN							
SS-132LN							
SS-212N	14,2	6,6	10,6	10,4	5,6	22	
SS-232N	14,2	6,6	10,6	10,4	5,6	17,8	
SS-312	16,4	7,68	10,6	11,6	5,6	23,2	
SS-332	16,4	7,68	10,6	11,6	5,6	19,2	
SS-532	16,4	7,68	10,6	11,6	5,6	20	
SS-732	17,4	8,4	11,2	12	6	24,6	
SS-1032	17,4	8,4	11,2	12	6	24,6	
SS-1532	18,4	8,72	12,24	14	7,72	27,68	
<b>SSA</b>							
SSA-0511N	9,2	4,08	7,2	4,4	3,4	15,6	12,8
SSA-0512N							
SSA-111N	11,6	5,4	9	5,2	4,6	18,8	23,6
SSA-112N							
SSA-111LN	12,8	6	9	5,2	4,68	18,8	23,6
SSA-112LN							



## SSM / SMA Series

### Submersible Vortex Pump

#### FEATURES:

The specially designed non-clog impeller will create vortex inside the pump casing. The impeller without projector will be especially suitable for transportation of drainage containing belt-shaped piece goods and fiber materials.

#### APPLICATIONS:

Drainage of the sewerage/waste water from following industries.

1. Confined livestock feeding industry.
2. Food sluff processing factory.
3. Pulp and paper industry.
4. Other relative industrial factories.

#### CROSS SECTION

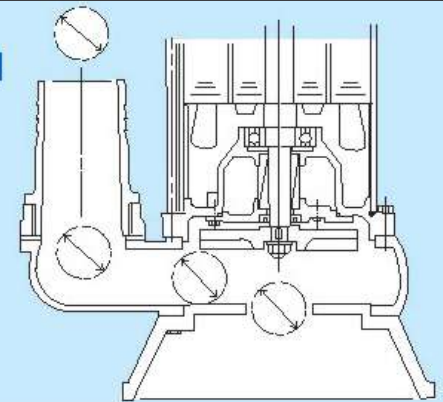

#### PERFORMANCE CURVES:

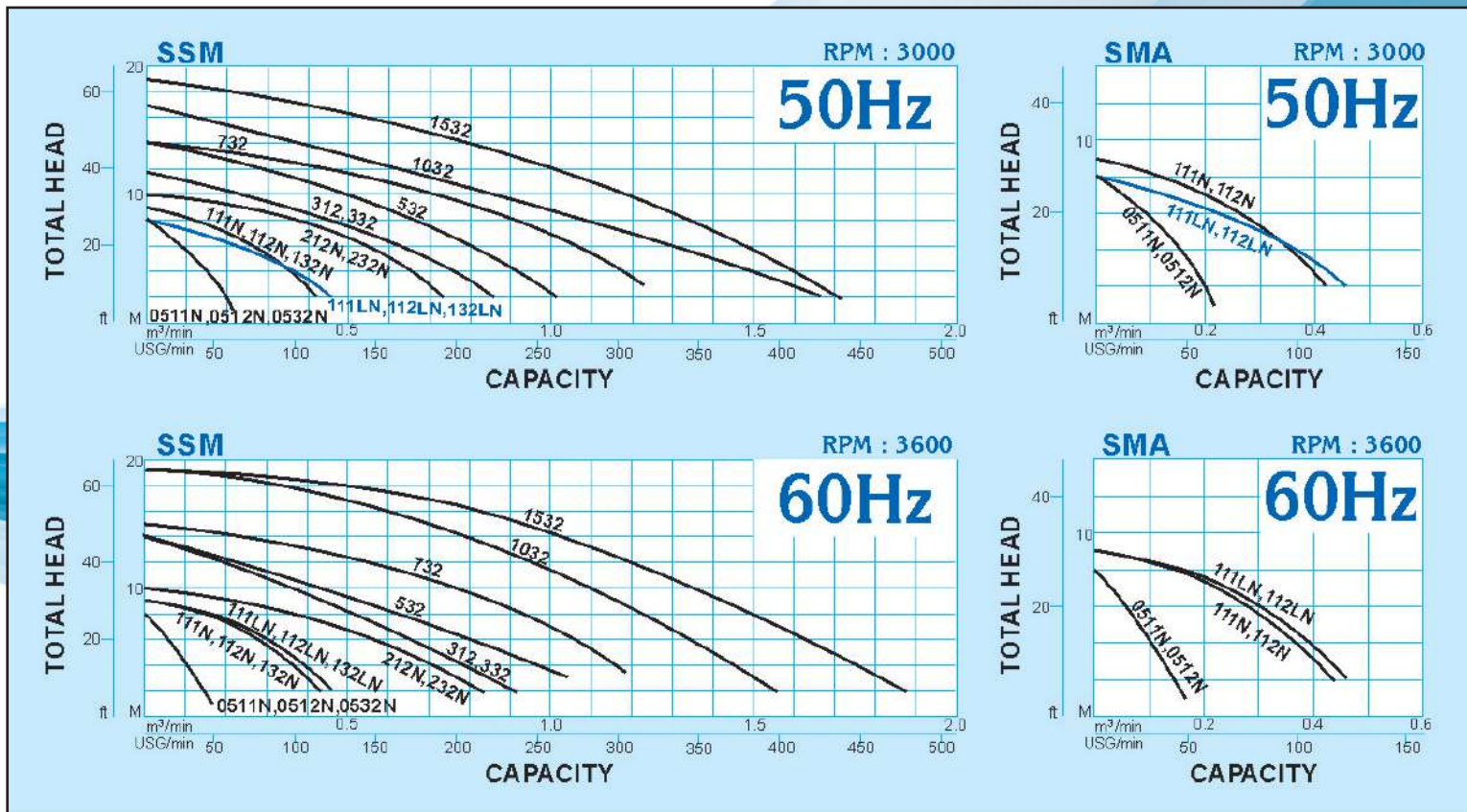



# SEWAGE VORTEX PUMPS

## SSM/SMA Series Vortex Sewage Pump

### SPECIFICATIONS:

### DIMENSIONS (MM):

TYPE		MOTOR				Disch. Diam.		Solid Passage	Cable	Weight	SIZE								
✓	✓	Power	Amp.	Phase	Volt						A	B	C	D	E	F	G		
		HP	KW	Start	Run	PH	V	in	mm	mm	mm <sup>2</sup> xM	KG	mm	mm	mm	mm	mm	mm	
	<b>SSM</b>																		
	<b>SMA</b>																		
		<b>SS/SST : Manual Type SS (With Ceramic Carbon Seal) SST(With Silicon carbide Seal)</b>																	
	<b>SSM-0511N</b>					1	110	2	50	4	1.25 <sup>2</sup> x6	11	230	102	180	165	85	350	320
	<b>SSM-0512N</b>	1/2	0.4			3	200-480												
	<b>SSM-0532N</b>																		
	<b>SSM-111N</b>					1	110	2	50	13	2 <sup>2</sup> x6	22	290	135	225	205	115	470	590
	<b>SSM-112N</b>	1	0.75			3	200-480												
	<b>SSM-132N</b>																		
	<b>SSM-111LN</b>					1	110	3	80	13	2 <sup>2</sup> x6	24	320	150	225	240	117	470	590
	<b>SSM-112LN</b>	1	0.75			3	200-480												
	<b>SSM-132LN</b>																		
	<b>SSM-212N</b>	2	1.5			1	200-480	3	80	15	3.5 <sup>2</sup> x10	36	355	165	265	260	140	550	
	<b>SSM-232N</b>					3	200-480					30	355	165	265	260	140	445	
	<b>SSM-312</b>	3	2.2			1	200-480	4	100	24	3.5 <sup>2</sup> x10	53	410	192	265	290	140	580	
	<b>SSM332</b>					3	200-480					45	410	192	265	290	140	480	
	<b>SSM-532</b>	5	3.7			3	200-480	4	100	28	3.5 <sup>2</sup> x10	49	410	192	265	290	140	500	
	<b>SSM-732</b>	7 1/2	5.5			3	200-480	4	100	22	5.5 <sup>2</sup> x10	77	435	210	280	300	150	615	
	<b>SSM-1032</b>	10	7.5			3	200-480	4	100	19	5.5 <sup>2</sup> x10	88	435	210	280	300	150	615	
	<b>SSM-1532</b>	15	11			3	200-480	4	100	22	8 <sup>2</sup> x10	120	460	218	306	350	193	692	

### DIMENSIONS (IN):

TYPE		SIZE						
		A	B	C	D	E	F	G
		mm	mm	mm	mm	mm	mm	mm
<b>SSM</b>	<b>SMA</b>							
<b>SSM-0511N</b>	<b>SMA-0511N</b>							
<b>SSM-0512N</b>	<b>SMA-0512N</b>	9,2	4,08	7,2	6,6	3,4	14	12,8
<b>SSM-0532N</b>								
<b>SSM-111N</b>	<b>SMA-111N</b>							
<b>SSM-112N</b>	<b>SMA-112N</b>	11,6	5,4	9	8,2	4,6	18,8	23,6
<b>SSM-132N</b>								
<b>SSM-111LN</b>	<b>SMA-111LN</b>							
<b>SSM-112LN</b>	<b>SMA-112LN</b>	12,8	6	9	9,6	4,68	18,8	
<b>SSM-132LN</b>								
<b>SSM-212N</b>		14,2	6,6	10,6	10,4	5,6	22	
<b>SSM-232N</b>		14,2	6,6	10,6	10,4	5,6	17,8	
<b>SSM-312</b>		16,4	7,68	10,6	11,6	5,6	23,2	
<b>SSM332</b>		16,4	7,68	10,6	11,6	5,6	19,2	
<b>SSM-532</b>		16,4	7,68	10,6	11,6	5,6	20	
<b>SSM-732</b>		17,4	8,4	11,2	12	6	24,6	
<b>SSM-1032</b>		17,4	8,4	11,2	12	6	24,6	
<b>SSM-1532</b>		18,4	8,72	12,24	14	7,72	27,68	

## SSM-V / SMA-V Series

### Vortex Sewage Pump

Vortex Impeller and Wide Pump Casing Interior eliminates the Possible Clogging and Entanglement of Solids and Fibrous Matter.

#### FEATURES:

##### EPOXY Cable Sealing Base

(EPOXY) Waterproof cable prevent water infiltration, cable ends sealed with epoxy resin, and lead wires are partially tripped off for perfect resin sealing. Triple protection for the motor against water penetration.



##### Built-in Motor Protector

Every STO type are equipped with a self-reset circle thermal protector to prevent over-loading, locking of impeller, and scorch damage to the motor from phase failure.



##### SiC Mechanical Seal

Equipped with double mechanical seals and adopted with heat-and-corrosion resistant silicon carbide mechanical seal for preventing the motor from water infiltration.



##### SiC Mechanical Seal

The specially designed non-clog impeller will create a high speed whirlpool inside the pump casing. The impeller with projection will be especially suitable for transportation of sewage containing belt-shaped piece goods, fibrous and stinky material.

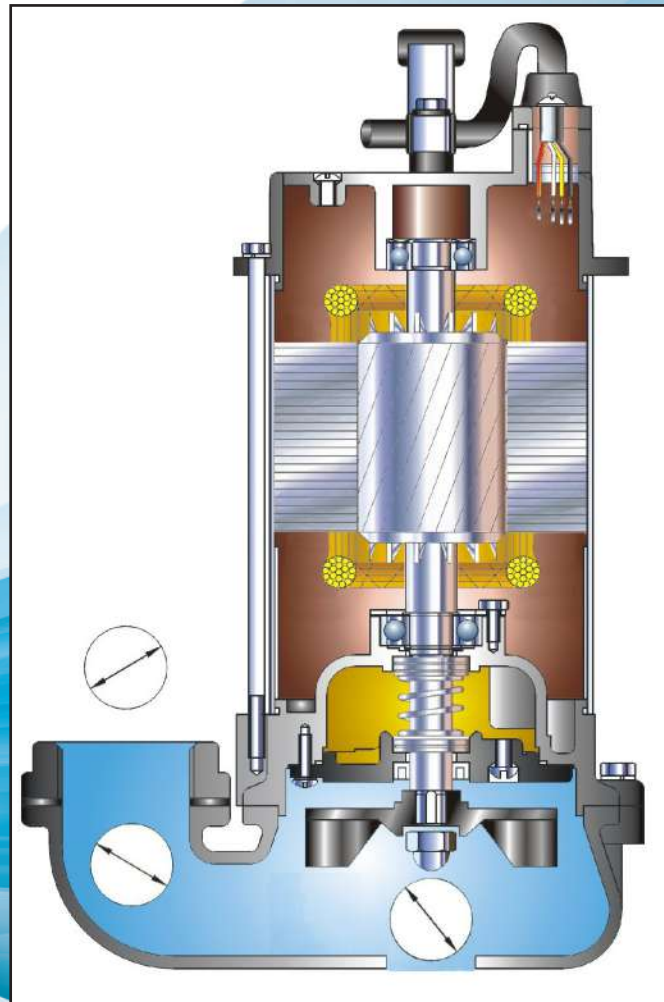





## SSM-V / SMA-V Series

## Vortex Sewage Pump

## SPECIFICATIONS OF TOS-SSM:

TYPE	Discharge Bore	Weight
TOS-50-SSM	2" (50 mm)	20 kG (44,09 LBS)
TOS-80-SSM	3" (80 mm)	34 kG (74,96 LBS)

## STANDARD ACCESSORIES OF GUIDE RAIL KIT:

Part NO.	Description	Material
16	Flange Setter	Cast iron
54	Shackle	SUS304
97	Lifting chain	SUS304
125	Guide Connector	Cast iron
126	Upper Guide Support	Cast iron
129	Duck Foot Bend	Cast iron

\*The guide pipes are not included in the kit.

## TOS-SSM Type Guide Rail Kit (Optional, 11)

Customer can order the TOS type «Guide Rail Kit» to perform connection/disconnection between a pump and piping only by lifting the pump down/up along guide pipes, so the maintenance and inspection can be done without entering a pit.

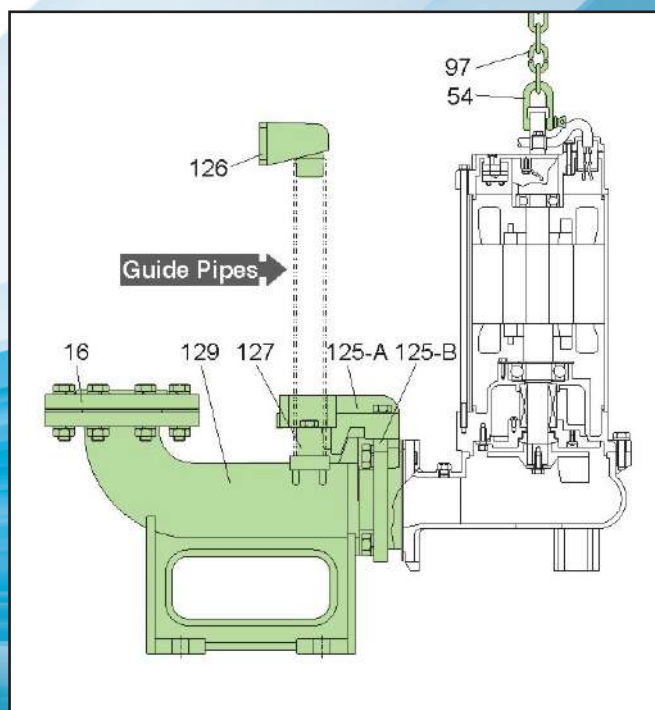



# SEWAGE VORTEX PUMPS

## SSM-V / SMA-V Series

### Vortex Sewage Pump

#### PERFORMANCE CURVES:

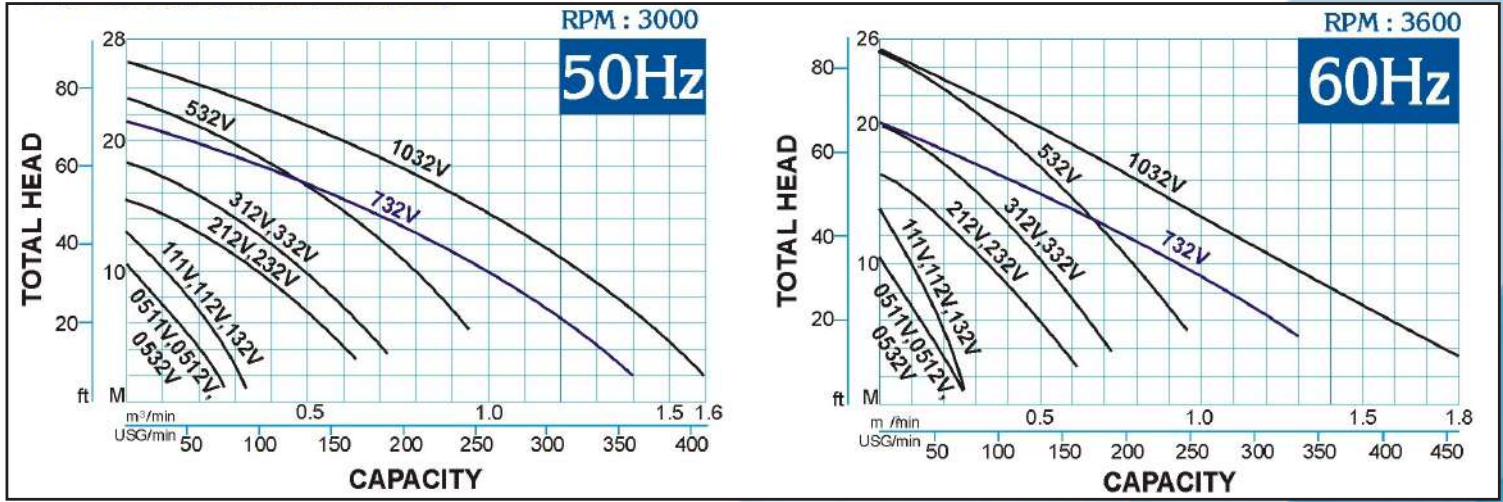

#### CONSTRUCTIONS:

**SSM-V  
SMA-V  
1/2 HP, 1HP**

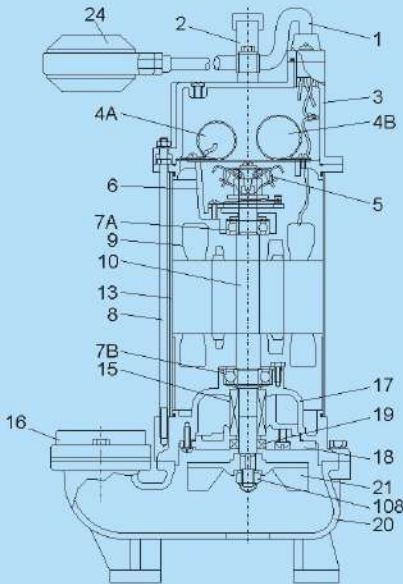

NO.	PARTS LIST	MATERIAL
1	Cable	V.C.T.
2	Handle	Stainless Steel
3	Motor Head Cover	Cast Iron
4A	Capacitor (starting)	for SSM/SMA-111V only
4B	Capacitor (running)	1φ only
5	Centrifugal Switch	for SSM/SMA-111V only
6	Upper Bracket	Cast Iron
7A	Bearing	
7B	Bearing	
8	Bolt	Stainless Steel
9	Coil	
10	Shaft	S45C
13	Motor Casing	Stainless Steel
15	Mechanical Seal	Silicon Carbide
16	Flange Setter	Cast Iron
17	Motor Lower Cover	Cast Iron
18	Mechanical Seal Cover	Plastic
19	Oil Seal	
20	Pump Casing	Cast Iron
21	Impeller	Cast Iron
24	Floating Switch	for SMA-V only
108	Nut	Stainless Steel

**SSM-V  
2 HP ~ 10 HP**

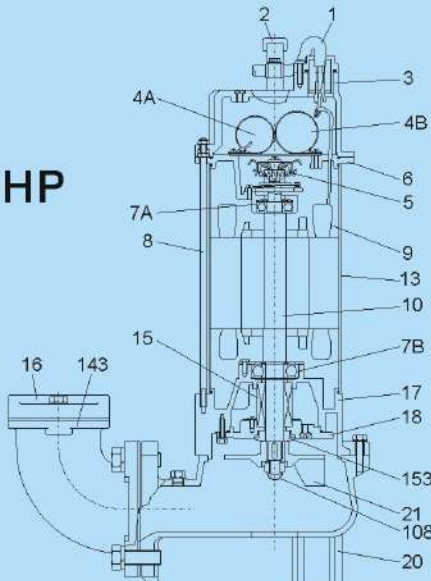

NO.	PARTS LIST	MATERIAL
1	Cable	V.C.T.
2	Handle	Stainless Steel
3	Motor Head Cover	Cast Iron
4A	Capacitor	1φ only
4B	Capacitor	1φ only
5	Centrifugal Switch	1φ only
6	Upper Bracket	Cast Iron
7A	Bearing	
7B	Bearing	
8	Bolt	Stainless Steel
9	Coil	
10	Shaft	S45C
13	Motor Casing	Stainless Steel
15	Mechanical Seal	Silicon Carbide
16	Flange Setter	Cast Iron
17	Motor Lower Cover	Cast Iron
18	Mechanical Seal Cover	Cast Iron
20	Pump Casing	Cast Iron
21	Impeller	Cast Iron
108	Nut	Steel
143	Elbow	Cast Iron
153	Sand Proof Trap	Synthetic Rubber





# SEWAGE VORTEX PUMPS

## SSM-V / SMA-V Series

### Vortex Sewage Pump

#### DIMENSIONS:

C.W.L. : Continuous Running Water Level  
L.W.L. : Lowest Running Water Level

SSM-0511V  
SSM-0512V  
SSM-0532V

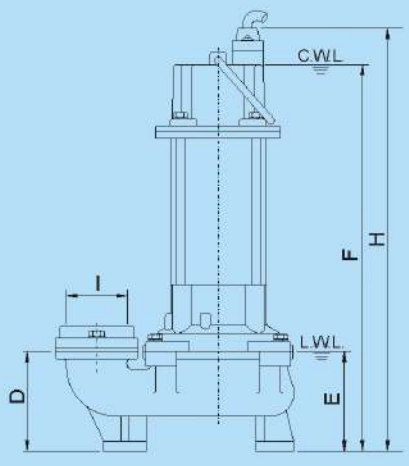
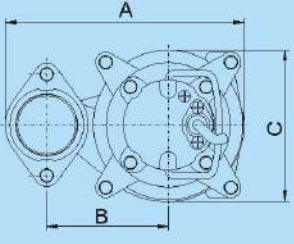

SSM-111V  
SSM-112V  
SSM-132V

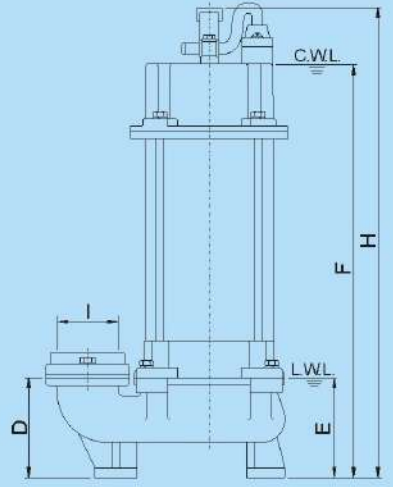
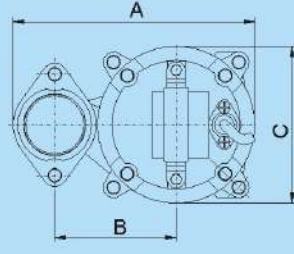

SSM-212V  
SSM-232V  
SSM-312V  
SSM-332V

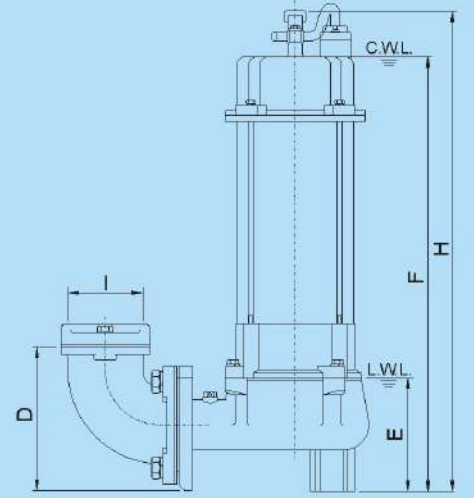
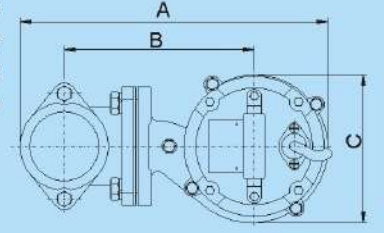

SSM-532V  
SSM-732V  
SSM-1032V

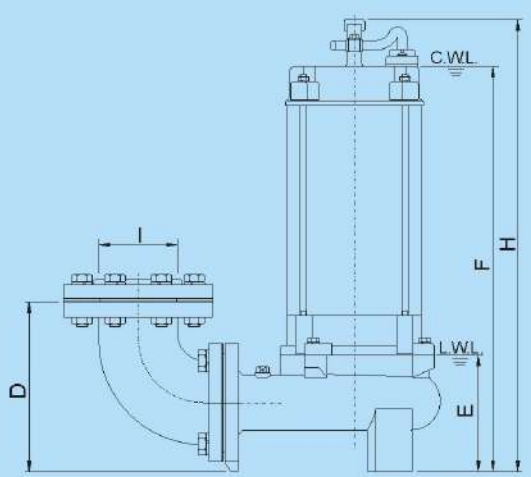
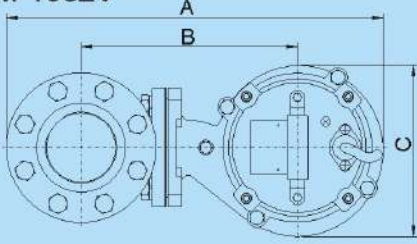

SMA-0511V  
SMA-0512V

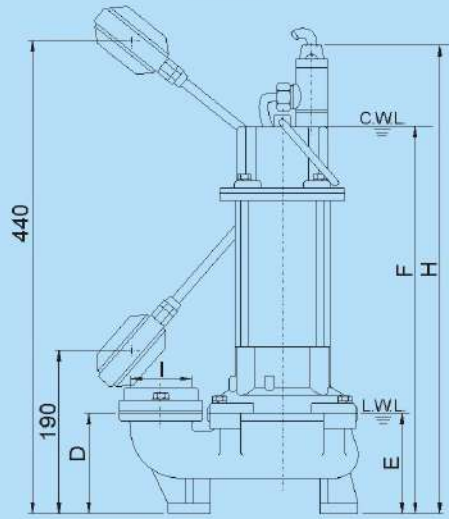
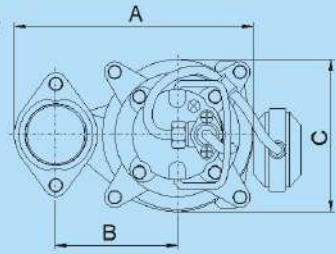

SMA-111V  
SMA-112V

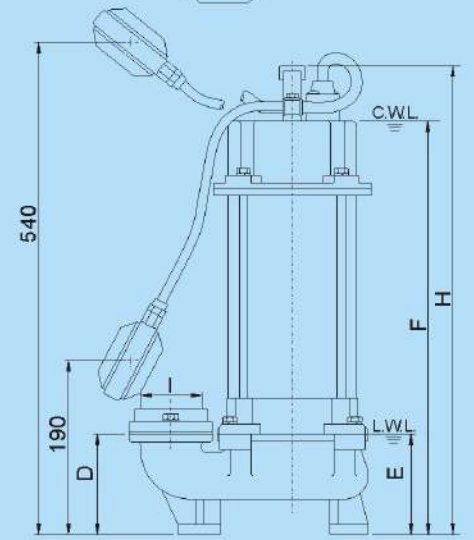
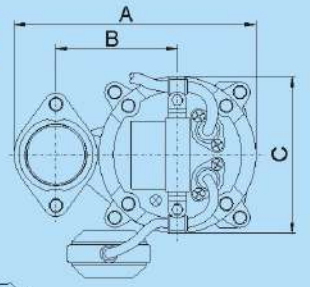





## SEWAGE VORTEX PUMPS

# SSM-V / SMA-V / TOS Series

## Vortex Sewage Pump

### DIMENSIONS:

TYPE	A		B		C		D		E		F		H		I	
	MM	IN	MM	IN	MM	IN	MM	IN	MM	IN	MM	IN	MM	IN	MM	IN
<b>SSM-0511V</b>	236	9,44	120	4,8	150	6	99	3,96	99	3,96	382	15,28	420	16,8	50	2
<b>SSM-0512V</b>	236	9,44	120	4,8	150	6	99	3,96	99	3,96	382	15,28	420	16,8	50	2
<b>SSM-0532V</b>	236	9,44	120	4,8	150	6	99	3,96	99	3,96	382	15,28	420	16,8	50	2
<b>SSM-111V</b>	240	9,6	120	4,8	155	6,2	99	3,96	99	3,96	409	16,36	465	18,6	50	2
<b>SSM-112V</b>	240	9,6	120	4,8	155	6,2	99	3,96	99	3,96	409	16,36	465	18,6	50	2
<b>SSM-132V</b>	240	9,6	120	4,8	155	6,2	99	3,96	99	3,96	409	16,36	465	18,6	50	2
<b>SSM-212V</b>	380	15,2	235	9,4	182	7,28	177	7,08	140	5,6	537	21,48	593	23,72	80	3,2
<b>SSM-232V</b>	380	15,2	235	9,4	182	7,28	177	7,08	140	5,6	456	18,24	512	20,48	80	3,2
<b>SSM-312V</b>	380	15,2	235	9,4	182	7,28	177	7,08	140	5,6	547	21,88	603	24,12	80	3,2
<b>SSM-332V</b>	380	15,2	235	9,4	182	7,28	177	7,08	140	5,6	476	21,88	532	21,28	80	3,2

TYPE	A		B		C		D		E		F		H		I	
	MM	IN	MM	IN	MM	IN	MM	IN	MM	IN	MM	IN	MM	IN	MM	IN
<b>SSM-532V</b>	466	18,64	267	10,68	212	8,48	209	8,36	143	5,72	501	20,04	560	22,4	80	3,2
<b>SSM-732V</b>	500	20	275	11	270	10,8	254	10,16	170	6,8	562	22,48	700	28	80	3,2
<b>SSM-1032V</b>	500	20	275	11	270	10,8	254	10,16	170	6,8	562	22,48	700	28	80	3,2
<b>SMA-0511V</b>	236	9,44	120	4,8	150	6	99	3,96	99	3,96	382	15,28	463	18,52	50	2
<b>SMA-0512V</b>	236	9,44	120	4,8	150	6	99	3,96	99	3,96	382	15,28	463	18,52	50	2
<b>SMA-111V</b>	240	9,6	120	4,8	155	6,2	99	3,96	99	3,96	409	16,36	463	18,52	50	2
<b>SMA-112V</b>	240	9,6	120	4,8	155	6,2	99	3,96	99	3,96	409	16,36	463	18,52	50	2



# SEWAGE VORTEX PUMPS

## SSM-V / SMA-V / TOS Series Vortex Sewage Pump

### SPECIFICATIONS:

TYPE				MOTOR				Disch. Diam.		Solid Passage	Cable	Weight							
				Power		Phase	Volt												
✓		✓		HP	KW	PH	V	in	mm	mm	mm <sup>2</sup> xM	KG	LBS						
	<b>SSM-V</b>		<b>SMA-V</b>			<b>TOS-SSM</b>	<b>SSM-V ; Manual Type Guide Rail kit</b>		<b>SMA-V ; Automatic Type</b>		<b>TOS-SSM ;</b>								
	<b>SSM-0511V</b>		<b>SMA-0511V</b>			<b>TOS-50-SSM</b>	1/2	0.4	1	1 10	2"	50	35	1.25mm <sup>2</sup> x 6	16.5	36,38			
	<b>SSM-0512V</b>		<b>SMA-0512V</b>			<b>TOS-50-SSM</b>											3	200-480	2.00mm <sup>2</sup> x 6
	<b>SSM-0532V</b>					<b>TOS-50-SSM</b>													
	<b>SSM-111V</b>		<b>SMA-111V</b>			<b>TOS-50-SSM</b>	1	0.75	1	1 10	2"	50	35	2.00mm <sup>2</sup> x 6	20	44,09			
	<b>SSM-112V</b>		<b>SMA-112V</b>			<b>TOS-50-SSM</b>											3	200-480	2.00mm <sup>2</sup> x 6
	<b>SSM-132V</b>					<b>TOS-50-SSM</b>													
	<b>SSM-212V</b>					<b>TOS-80-SSM</b>	2	1.5	1	200-480	3"	80	50	3.5mm <sup>2</sup> x 10	42	92,59			
	<b>SSM-232V</b>					<b>TOS-80-SSM</b>											3	200-480	2.00mm <sup>2</sup> x10
	<b>SSM-312V</b>					<b>TOS-80-SSM</b>	3	2.2	1	200-480	3"	80	50	3.5mm <sup>2</sup> x 10	44	97,00			
	<b>SSM-332V</b>					<b>TOS-80-SSM</b>											3	200-480	2.0mm <sup>2</sup> x 10
	<b>SSM-532V</b>					<b>TOS-80-SSM</b>	5	3.7	3	200-480	3"	80	50	2.0mm <sup>2</sup> x 10	55	121,25			
	<b>SSM-732V</b>					<b>TOS-80-SSM</b>		5.5	3	200-480	3"	80	76	5.5mm <sup>2</sup> x 10	70	154,32			
	<b>SSM-1032V</b>					<b>TOS-80-SSM</b>	10	7.5	3	200-480	3"	80	76	5.5mm <sup>2</sup> x 10	76	167,55			

### AMPS :

TYPE	60Hz/1Ph		60Hz/3Ph			
	110V	220V	208V	230V	460V	575V
	Amp	Amp	Amp	Amp	Amp	Amp
<b>SSM-0511V</b>	8					
<b>SSM-0512V</b>		4				
<b>SSM-112V</b>		7				
<b>SSM-132V</b>			3.7	3.5	2	1.3
<b>SSM-212V</b>		14				
<b>SSM-232V</b>			6.3	5.8	2.9	2.3
<b>SSM-312V</b>		21				
<b>SSM-332V</b>			9.5	8.3	4.1	3.4
<b>SSM-532V</b>			15.9	13.8	7	5.7
<b>SMA-0511V</b>	8					
<b>SMA-0512V</b>		4				
<b>SMA-112V</b>		7				

## KL Series

### Submersible Large Volume Dewatering Pump

#### FEATURES:

1. Turbo Jet-Like impeller designed to improve extra-output water volume.
2. Easy operating, no need of equipped devices, result in this less-maintenance, noise and vibration free pump.
3. Rigid body, by using the special fined bronze and stainless steel, this will rise the pump the ability of water deliverling life.

#### APPLICATIONS:

1. It is applicable to agricultural, industrial use, as well as in accumulated water and large volume water pumping.
2. Widely used in aquaculture farm.
3. Extraction of water from the ponds, rivers and lakes.
4. Flood control and drainage system for industry
5. Water supply for fountains and water features.
6. Water discharge work for ships

#### PERFORMANCE CURVE:

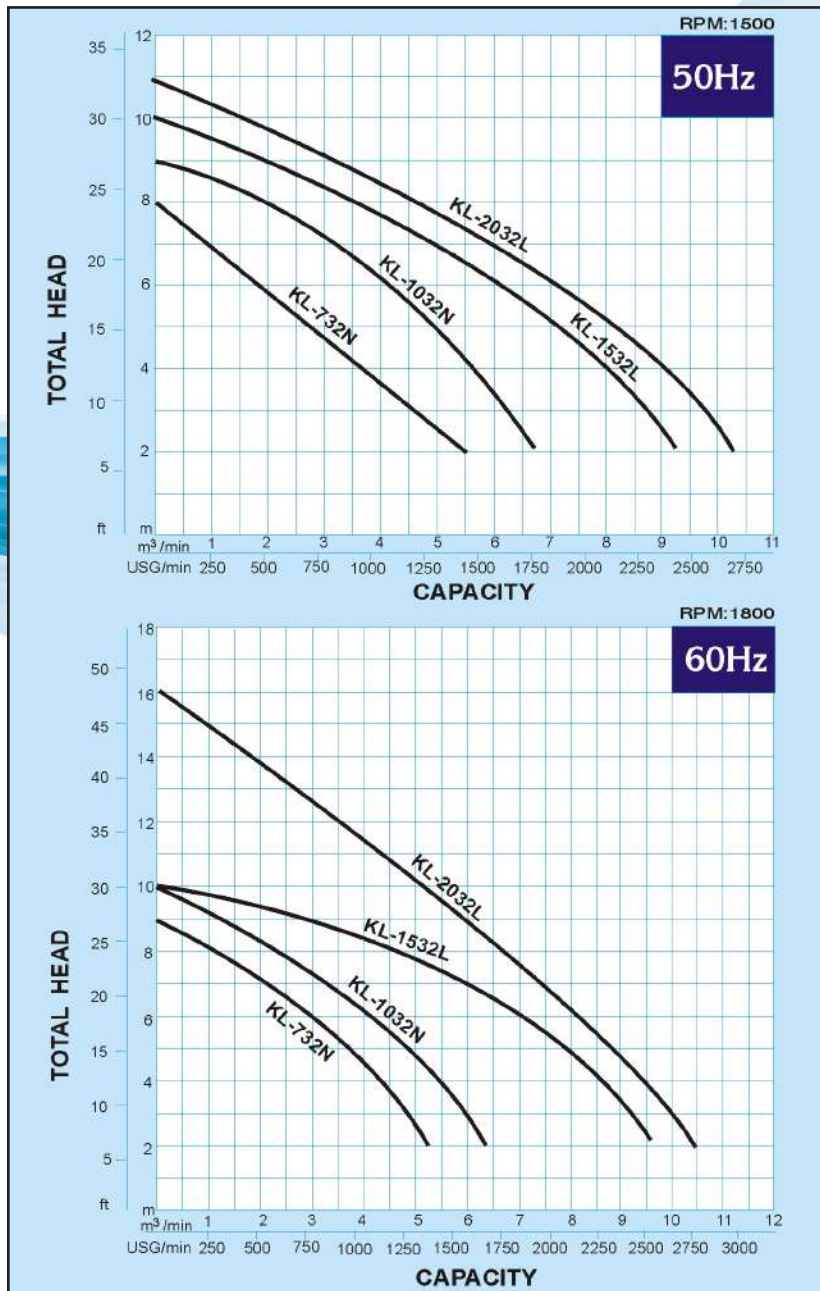

#### DIMENSIONS:

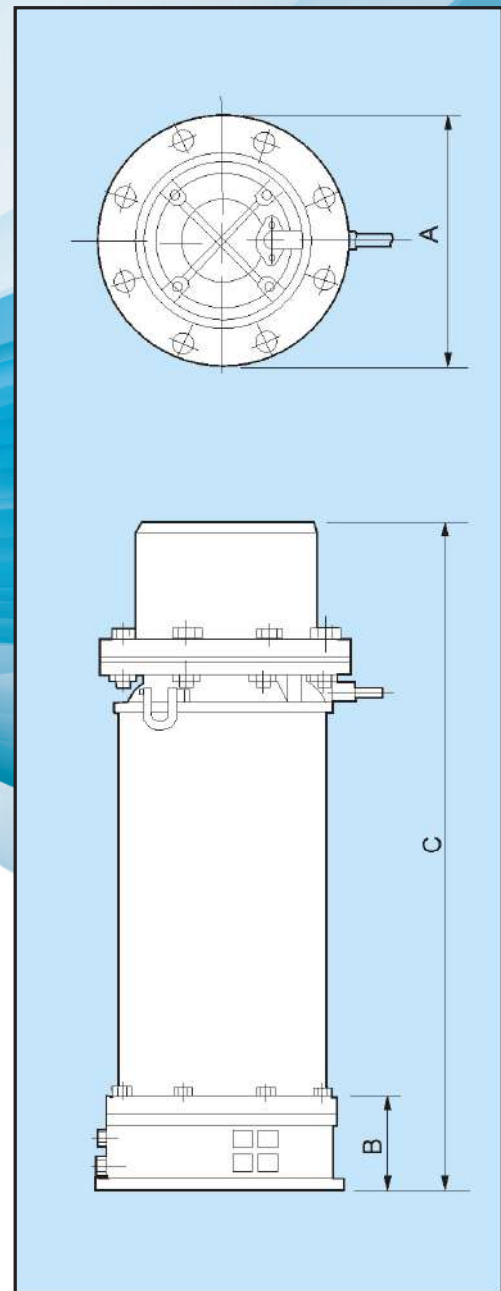





# DEWATERING PUMPS

## KS Series Submersible Dewatering Pump

### FEATURES:

1. Compact size, lightweight and easy operation. Specially top outlet design with easy connection, suitable for different types of dewatering work..
2. Since the motor cooled by water, and maintains in safety temperature when motor works; this will enlong the motor's life.
3. Specially designed impeller curvature to obtain larger output water volume.

### APPLICATIONS:

1. Basement drainage
2. Drainage system for industry
3. Agricultural and horticultural irrigation.
4. Water supply for fountains and water features.
5. Water discharge work for ships
6. Any kind of accumulated water and water discharge

### PERFORMANCE CURVES:

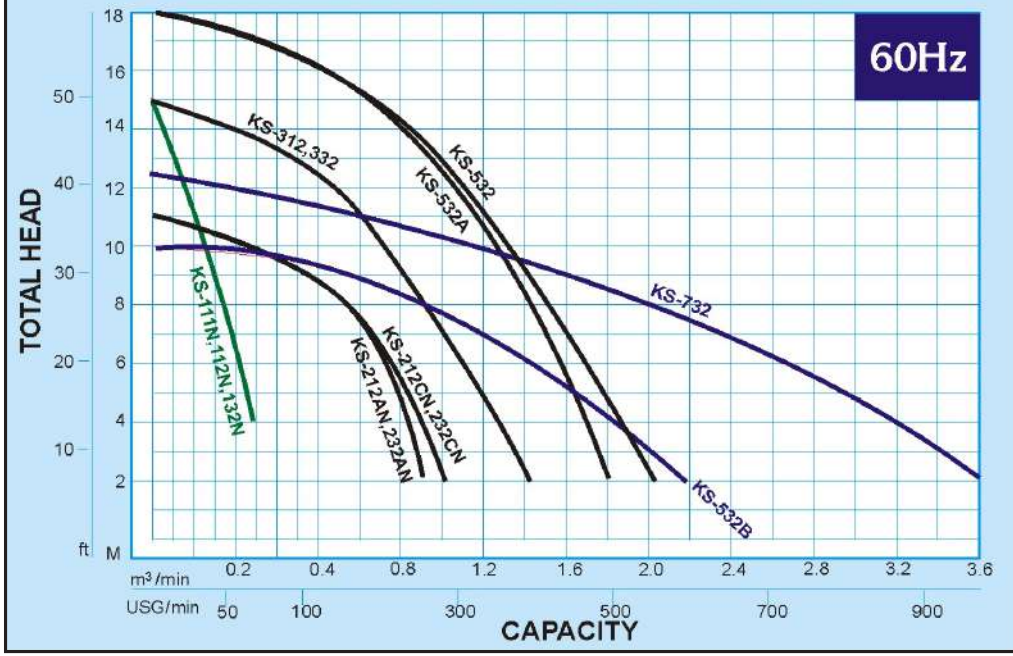
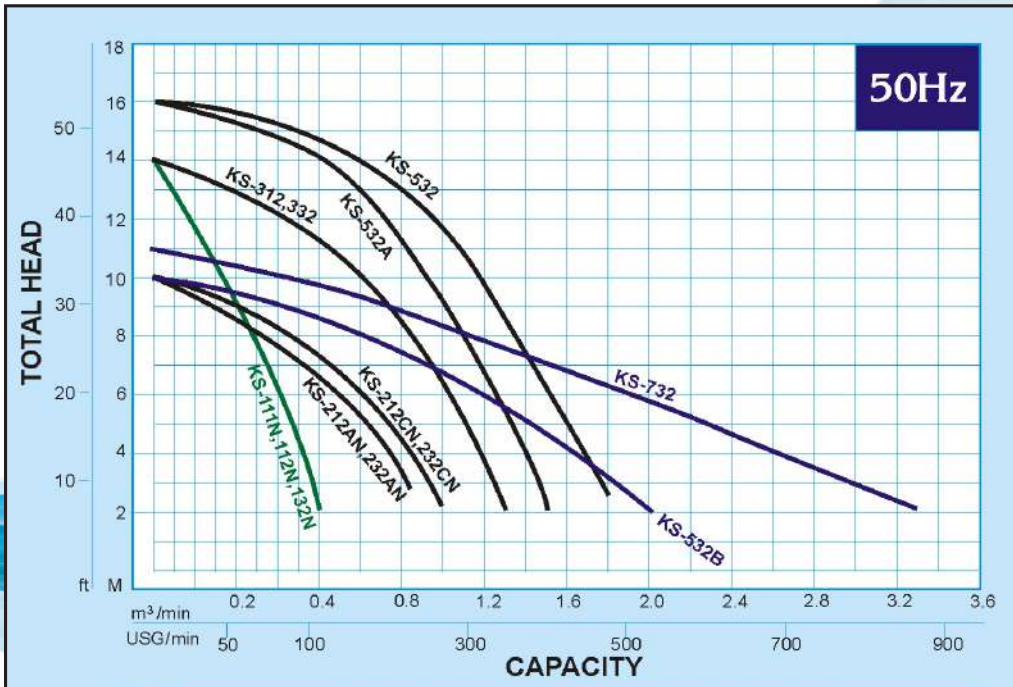

### DIMENSIONS:

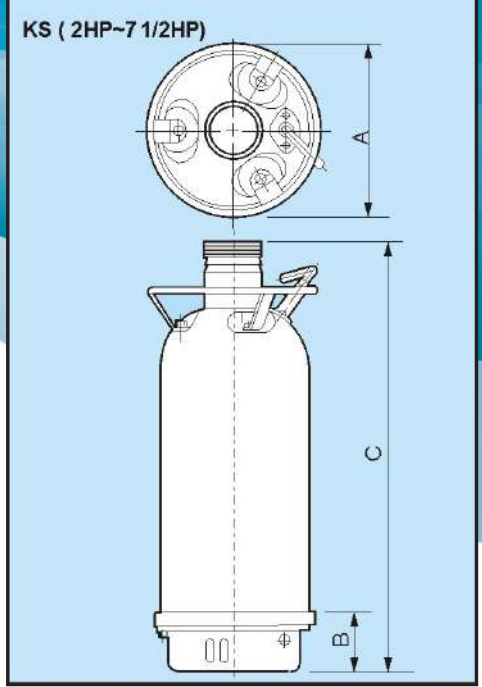
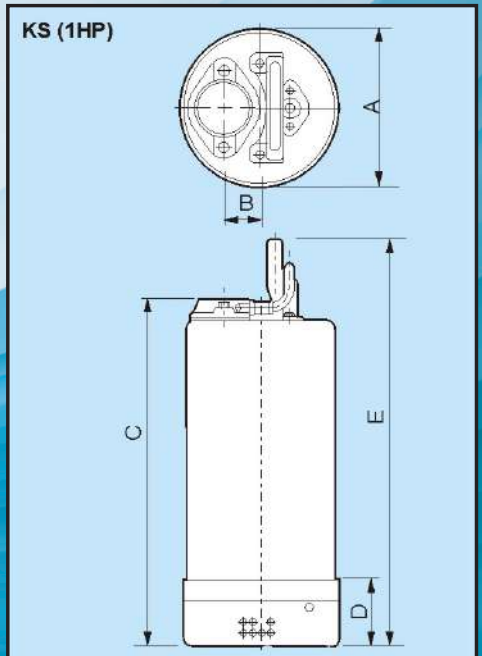



# DEWATERING PUMPS

## KL Series / KS Series Submersible (Large Volume) Dewatering Pump

### SPECIFICATIONS:

### DIMENSIONS: (MM):

✓	TYPE	MOTOR							Disch. Diam.	Solid Passage	Cable	Weight		SIZE						
		Power		Amp.		Phase	Volt	Poles				A		B		C				
		KW	HP	Start	Run	PH	V	P				in	mm	mm	mm <sup>2</sup> xM	KG	LBS	mm	in	mm
	<b>KL-732N</b>	5.5	7 1/2			3	220-440	4	8"	200	31 x22	5.5 <sup>2</sup> x10	118	260,15	376	15,04	200	8	915	36,6
	<b>KL-1032N</b>	7.5	10			3	220-440	4	10"	250	31 x22	5.5 <sup>2</sup> x10	165	363,76	422	16,88	200	8	1035	41,4
	<b>KL-1532L</b>	11	15			3	220-440	4	12"	300	31 x22	8 <sup>2</sup> X 10	191	421,08	422	16,88	200	8	1065	42,6
	<b>KL-2032L</b>	15	20			3	220-440	4	12"	300	31 x22	8 <sup>2</sup> X 10	195	429,90	422	16,88	200	8	1065	42,6

✓	TYPE	MOTOR							Disch. Diam.	Solid Passage	Cable	Weight		SIZE						
		Power		Amp.		Phase	Volt	Poles				A		B		C				
		KW	HP	Start	Run	PH	V	P				in	mm	mm	mm <sup>2</sup> xM	KG	LBS	mm	in	mm
	<b>KS-111N</b>	0.75	1			1	110	2	2"	50	ø6	2 <sup>2</sup> x 6	23	50,71	175	7	40	1,6	465	18,6
	<b>KS-112N</b>						220	2												
	<b>KS-132 N</b>						220-440	2												
	<b>KS-212AN</b>	1.5	2			1	220	2	3"	80	34 x 10	3.5 <sup>2</sup> x 10	41	90,39	228	9,12	80	3,2	615	24,6
	<b>KS-232AN</b>						220-440	2					33	72,75	228	9,12	80	3,2	515	20,6
	<b>KS-212CN</b>						220	2	41	90,39			228	9,12	80	3,2	610	24,4		
	<b>KS-232CN</b>						220-440	2	33	72,75			228	9,12	80	3,2	510	20,4		
	<b>KS-312</b>	2.2	3			3	220	2	4"	100	34 x 10	3.5 <sup>2</sup> x 10	48	105,82	228	9,12	80	3,2	630	25,2
	<b>KS-332</b>						220-440	2					42	92,59	228	9,12	80	3,2	530	21,2
	<b>KS-532A</b>	3.7	5			3	220-440	2	4"	100	34 x 10	3.5 <sup>2</sup> x 10	49	108,03	232	9,28	100	4	560	22,4
	<b>KS-532</b>						220-440	2	5"	125			232	9,28	100	4	560	22,4		
	<b>KS-532B</b>						220-440	4	6"	150	50 x 11		85	187,39	272	10,88	125	5	825	33
	<b>KS-732</b>	5.5	7 1/2			3	220-440	4	6"	150	31 x 22	5.5 <sup>2</sup> x 10	107	235,89	335	13,4	200	8	750	30





# DEWATERING PUMPS

## KL Series / KS Series Submersible (Large Volume) Dewatering Pump

### CONSTRUCTIONS:

KS

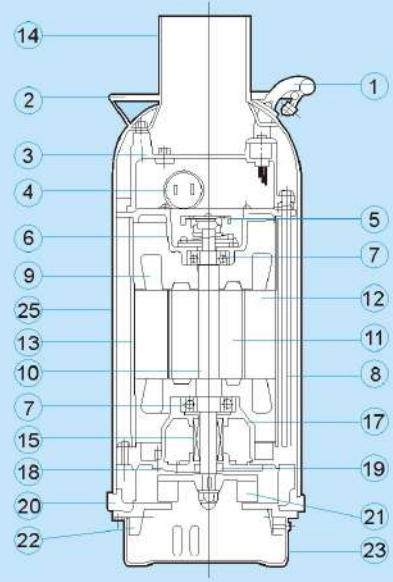

NO.	PARTS LIST	MATERIAL
1	Cable	V.C.T.
2	Handle	Stainless Steel
3	Motor Head Cover	Cast Iron
4	Condenser	1 φ only
5	Centrifugal Switch	1 φ only
6	Upper Bracket	Cast Iron
7	Upper Ball Bearing	
8	Bolt	Stainless Steel
9	Coil	
10	Shaft	Stainless Steel
11	Rotor	Steel Plate
12	Stator	Steel Plate
13	Motor Casing	Stainless Steel
14	Hose Coupling	Stainless Steel
15	Mechanical Seal	Ceramic-Carbon
17	Motor Lower Cover	Cast Iron
18	Mechanical Seal Cover	Cast Iron
19	Oil Seal	Synthetic Rubber
20	Pump Casing	Cast Iron
21	Impeller	Bronze
22	Suction Cover	Bronze Cast Iron (1HP & KS-532B)
23	Strainer	Stainless Steel
25	Outer Cover	Stainless Steel

KL

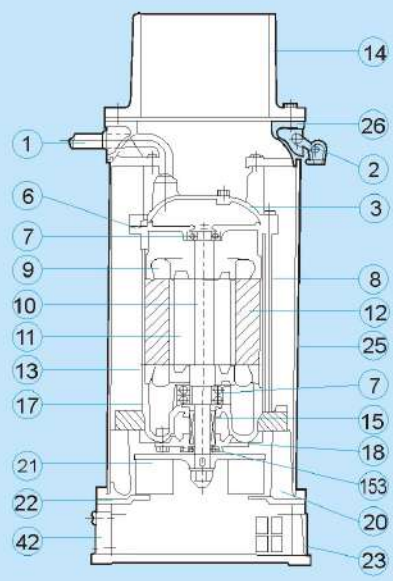

NO.	PARTS LIST	MATERIAL
1	Cable	V.C.T.
2	Handle	Stainless Steel
3	Motor Head Cover	Bronze
6	Upper Bracket	Bronze (15&20HP)
7	Upper Ball Bearing	
8	Bolt	Stainless Steel
9	Coil	
10	Shaft	Stainless Steel
11	Rotor	Steel Plate
12	Stator	Steel Plate
13	Motor Casing	Stainless Steel
14	Hose Coupling	Cast Iron
15	Mechanical Seal	Ceramic-Carbon
17	Motor Lower Cover	Bronze
18	Mechanical Seal Cover	Cast Iron
20	Pump Casing	Cast Iron
21	Impeller	Bronze
22	Suction Cover	Bronze
23	Strainer	Stainless Steel
25	Outer Cover	Stainless Steel
26	Bracket of Outer Cover	Cast Iron
42	Strainer Stand	Cast Iron
153	Sand Proof Trap	Synthetic Rubber

### APPLICATION EXAMPLES:

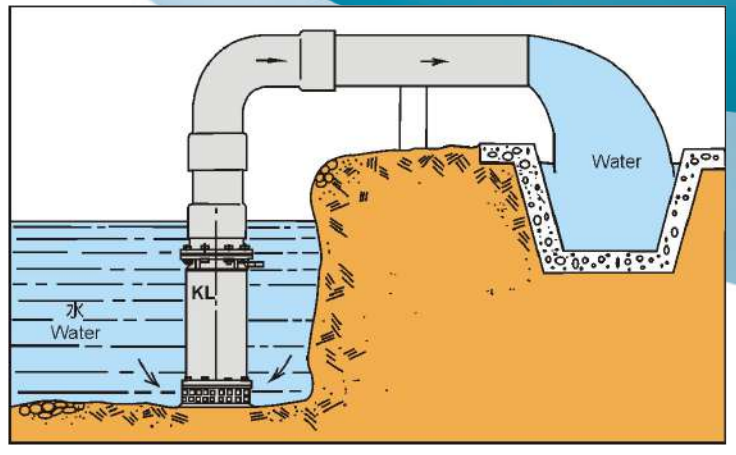
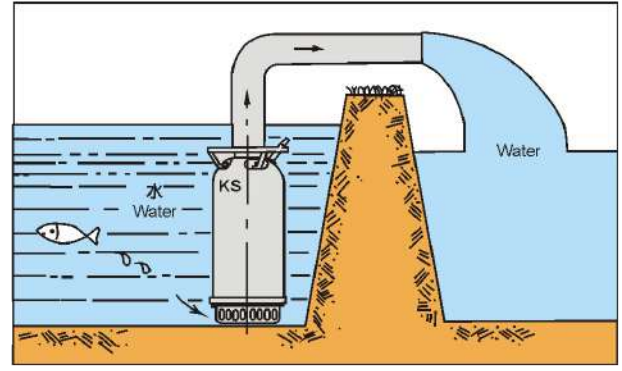



## KT Series Submersible Contractor Pump

For Sand Mixed Water of Civil Construction  
Equipped with Silicon Carbide Mechanical Seal  
Impeller and Suction Cover are made of HCr

### FEATURES:

1. 2-pole motor with high speed rotation achieves the extra high-head water carrying.
2. The impeller and its suction cover were made of the high chromium and specially treated, so as to enlong the workability.
3. The mechanical seal is of silicon carbide made ensures the super durability.

### APPLICATIONS:

CONSTRUCTION - Excavation, sump, ditch, tunnel, any foundation work & storm water removal.  
 FACTORIES-Waste water removal, sump pit. manhole, basement, emergency water removal & industrial processing water.  
 BUILDINGS-Sump pit. plumbing, manhole, elevator pit. emergency & storm water removal.  
 UTILITIES-Excavation. sump, manhole, trench, sewage tunnel & storm water removal.  
 MINING-Pit.quarry, sump, excavation, tunnel & storm water removal.  
 HOME-Cellar. sump. pit. plumbing, fountain & swimming pool cleaning.  
 FARMING-Irrigation & fire protection.  
 MARINE-Bilge. fire fighting & wash-down

KT1032/1032H

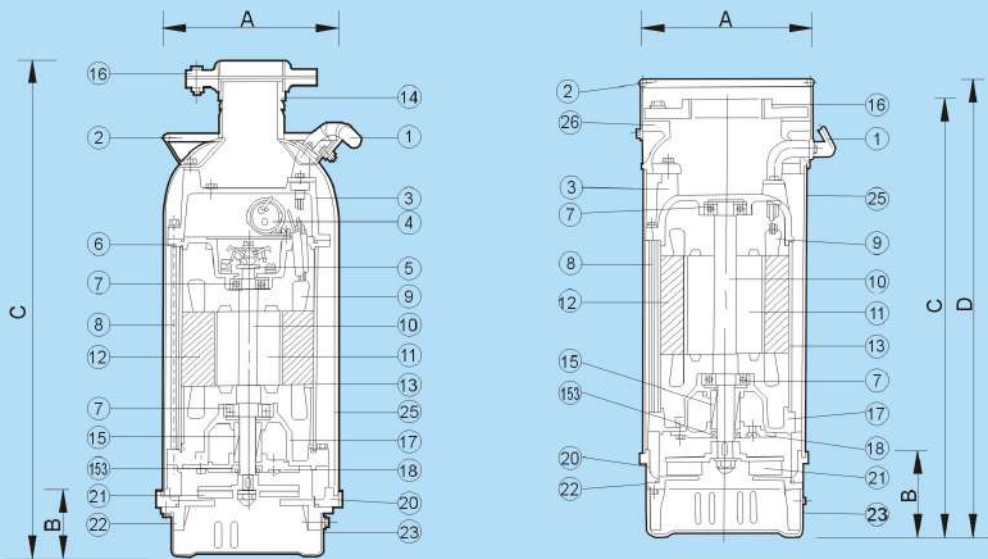

NO.	PARTS LIST	MATERIAL
1	Cable	V.C.T.
2	Handle	Stainless Steel
3	Motor Head Cover	Cast Iron
4	Condenser	(1Ø only)
5	Centrifugal Switch	(1Ø only)
6	Upper Bracket	Cast Iron (1Ø only)
7	Upper Ball Bearing	
8	Bolt	Stainless Steel
9	Coil	
10	Shaft	S45C+ SUS304 SUS304 (5HP)
11	Rotor	Steel Plate
12	Stator	Steel Plate

NO.	PARTS LIST	MATERIAL
13	Motor Casing	Stainless Steel
14	Hose Coupling	Stainless Steel
15	Mechanical Seal	Silicon Carbide
16	Flange Setter	Cast Iron
17	Motor Lower Cover	Cast Iron
18	Mechanical Seal Cover	Cast Iron
20	Pump Casing	Cast Iron
21	Impeller	High Chromium
22	Suction Cover	High Chromium
23	Strainer	Stainless Steel
25	Outer Cover	Stainless Steel
26	Bracket of Outer Cover	Cast Iron (10HP)
153	Sand Proof Trap	Synthetic Rubber



## KT Series Submersible Contractor Pump

### PERFORMANCE CURVES:

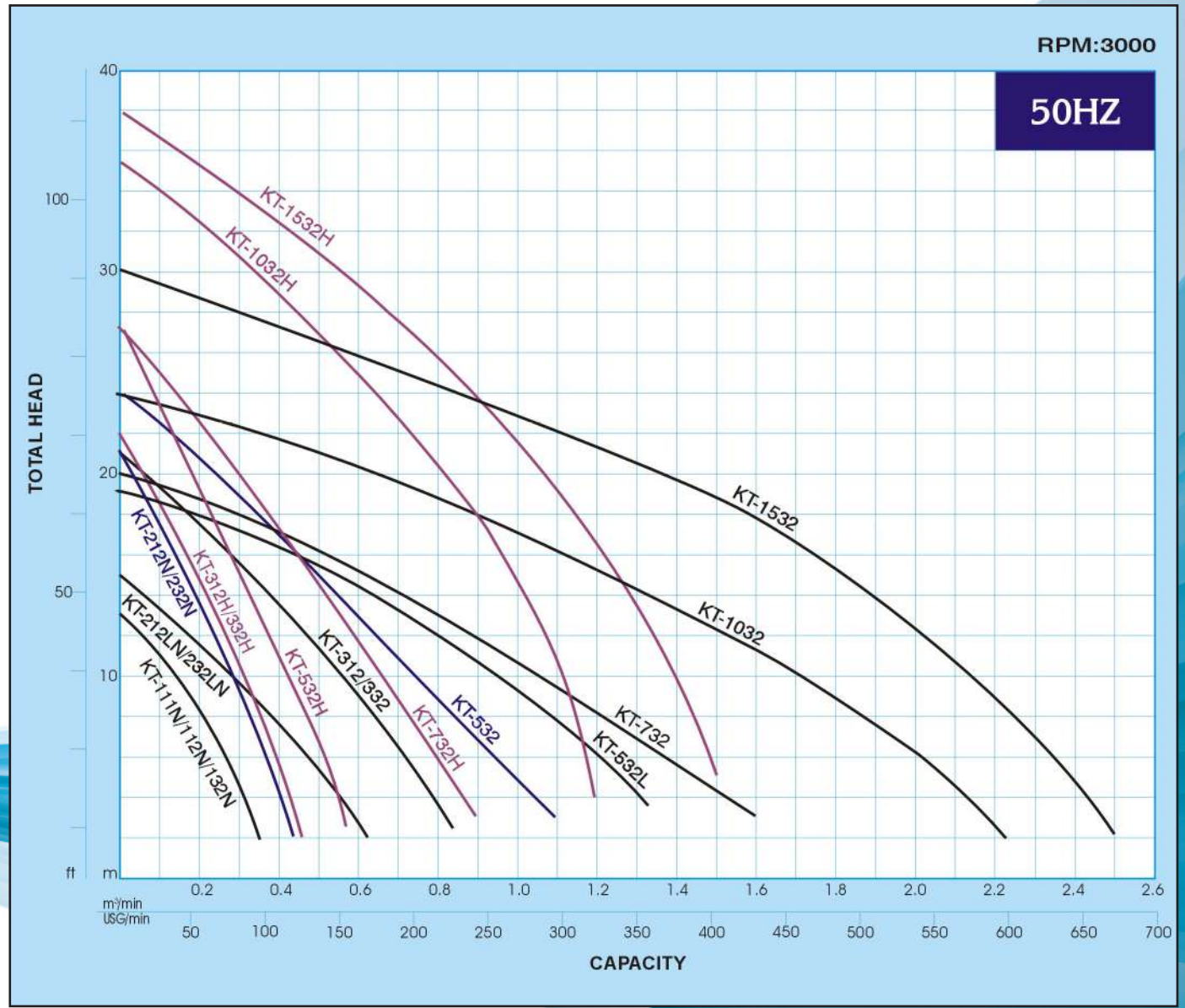



## KT Series Submersible Contractor Pump

### 50 Hz SPECIFICATIONS:

### DIMENSIONS:

✓	TYPE	MOTOR					PUMP					Cable	Weight		SIZE								
		Power		Amp.		Phase	Volt	Disch. Diam.		Max head	Max-Flow		Solid Passage	KG	LBS	A		B		C		D	
		KW	HP	Start	Run	PH	V	mm	in	M	M <sup>3</sup> /min	mm	mm <sup>2</sup> xM			mm	in	mm	in	mm	in	mm	in
	KT-111N	0.75	1			1	110	50	2»	13	0.3	ø6	2²x6	24	52,91	210	8,4	70	2,8	490	19,6		
	KT-112N			220																			
	KT-132N			220-440	3																		
	KT-212N	1.5	2			3	220	50	2»	21	0.45	34 x 10	3.5²x10	41	90,39	228	9,12	80	3,2	650	26		
	KT-232N			220-440	1																		
	KT-212LN			220	3																		
	KT-232LN			220-440	1																		
	KT-312H	2.2	3			3	220	50	2»	22	0.4	34 x 10	3.5²x10	52	114,64	228	9,12	80	3,2	670	26,8		
	KT-332H			220-440	1																		
	KT-312			220	3																		
	KT-332			220-440	1																		
	KT-532H	3.7	5			3	220-440	50	2"	27	0.55	34 x 10	3.5²x10	49	108,03	232	9,28	100	4	605	24,2		
	KT-532			80	3"		24	1.1															
	KT-532L			100	4"		19	1.35															
	KT-732H	5.5	7 1/2			3	220-440	80	3"	27	0.9	50 x 11	5.5²x10	77	169,76	272	10,88	125	5	720	28,8		
	KT-732			100	4"		20	1.6															
	KT-1032H	7.5	10			3	220-440	100	4'	35	1.2	50 x 11	5.5²x10	91	200,62	272	10,88	125	5	665	26,6	700	28
	KT-1032			150	6"		24	2.3															
	KT-1532H	11	15			3	220-440	100	4'	38	1.5	31 x 22	8²x10	129	284,40	335	13,4	200	8	785	31,4		
	KT-1532			150	6"		30	2.5															





## KT Series Submersible Contractor Pump

### PERFORMANCE CURVES:

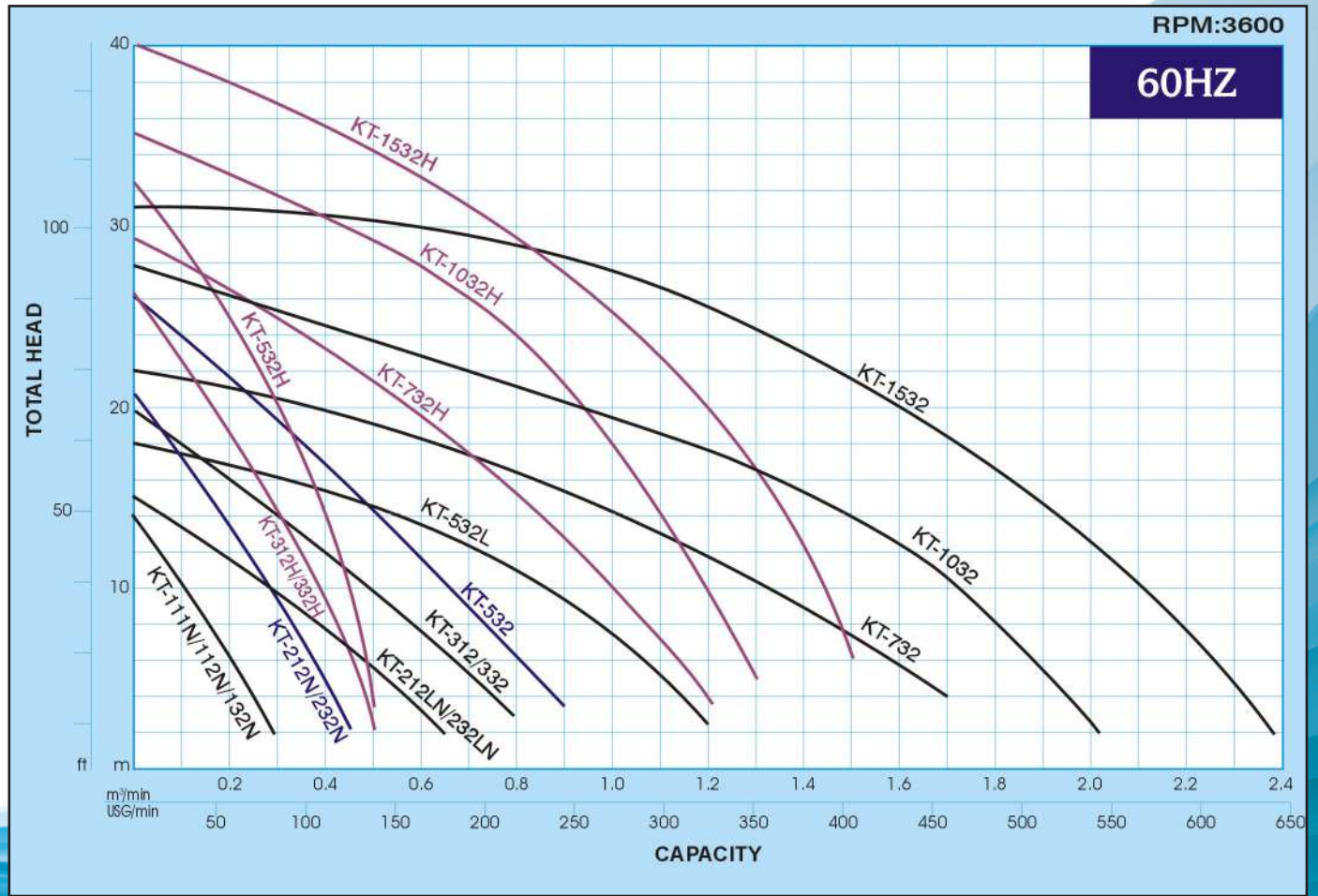

### 60 Hz SPECIFICATIONS:

### DIMENSIONS:

✓	TYPE	MOTOR				PUMP				Cable	Weight		SIZE										
		Power		Phase	Volt	Disch. Diam.		Max head	Max-Flow		Solid Passage	KG	LBS	A		B		C		D			
		KW	HP	PH	V	mm	in	M	M <sup>3</sup> /min		mm			mm <sup>2</sup> xM	mm	in	mm	in	mm	in	mm	in	
	KT-111N	0.75	1	1	110	50	2»	14	0.3	ø6	2»x6	24	52,91	210	8,4	70	2,8	490	19,6				
	KT-112N				220																		
	KT-132N				3															220-440			
	KT-212N	1.5	2	3	220	50	2»	21	0.45	34 x 10	3.5»x10	41	90,39	228	9,12	80	3,2	650	26				
	KT-232N				220-440																		
	KT-212LN				220	80	3»	15	0.65											41	90,39	650	26
	KT-232LN				220-440																		
	KT-312H	2.2	3	3	220	50	2»	26	0.5	34 x 10	3.5»x10	52	114,64	228	9,12	80	3,2	670	26,8				
	KT-332H				220-440																		
	KT-312				220	80	3»	20	0.8											52	114,64	670	26,8
	KT-332				220-440																		
	KT-532H	3.7	5	3	220-440	50	2"	32	0.5	34 x 10	3.5»x10	49	108,03	232	9,28	100	4	605	24,2				
	KT-532				80	3"	26	0.9															
	KT-532L				100	4"	18	1.2															
	KT-732H	5.5	7 1/2	3	220-440	80	3"	28	1.2	50 x 11	5.5»x10	77	169,76	272	10,88	125	5	720	28,8				
	KT-732				100	4"	22	1.7															
	KT-1032H	7.5	10	3	220-440	100	4'	35	1.3	50 x 11	5.5»x10	91	200,62	272	10,88	125	5	665	26,6	700	28		
	KT-1032				150	6"	28	2.0															
	KT-1532H	11	15	3	220-440	100	4'	40	1.5	31 x 22	8»x10	129	284,40	335	13,4	200	8	785	31,4				
	KT-1532				150	6"	31	2.4															

### AMPS :

TYPE	60Hz/1Ph			60Hz/3Ph		
	110V	220V	208V	230V	460V	575V
	Amp	Amp	Amp	Amp	Amp	Amp
KT-111N	14					
KT-112N		7				
KT-132N			3.7	3.5	2	1.3
KT-212N		14				
KT-232N			6.3	7	3.5	2.3
KT-212LN		14				
KT-232LN			6.3	7	3.5	2.3
KT-312H		21				
KT-332H			9.5	8.3	7.1	3.4
KT-532H			15.9	13.8	7	5.7
KT-532			15.9	13.8	7	5.7
KT-532L			15.9	13.8	7	5.7
KT-732H			22.2	19.3	9.6	8
KT-732			22.2	19.3	9.6	8
KT-1032H			31.7	27.5	13.8	11.5
KT-1032			31.7	27.5	13.8	11.5
KT-1532H			42.3	41.3	20.6	15.3
KT-1532			42.3	41.3	20.6	15.3



## GP type Submersible Grinder Pump





## GP Series Sewage Grinder Pump

### FEATURES:

1.The advanced integrated grinding mechanism particularly well-suited for use with liquids that may contain filaments, plastic bags, long fibers, rubber material etc.

2.The grinding mechanism is composed of a fixed blade and a rotating grinder made by hard Chromium-Molybdenum alloy steel that is highly resistant to the abrasion. There are 27 cutting edges on the fixed part. Then the two poles high torque motor will provide more than 80,000 shredding actions every minutes to perform an optimum shredding performance.

3.The triplex seals- Double mechanical seal plus an oil seal to isolate the motor from the sewage.

4.Unique Epoxy Cable Sealing Base ensures 100% capability to block the water vapor from entering the motor even the cable breaks.

5.Using dual ball bearing on the bottom of the motor to support the axial push.



**Pants**



**Cotton Gloves**



**Rags**



**Sanitary Pad**



**Plastic bags**



# SEWAGE GRINDER PUMPS

## GP Series Sewage Grinder Pump

### SPECIFICATIONS:

✓	TYPE			MOTOR								Disch. Diam.		50Hz		60 Hz		Cable		Weight	
				Power		Amp.		Phase	Volt	Max head	Max-Flow			Max head	Max-Flow						
	GP	GPA	TOS-GP	HP	KW	Start	Run	PH	V	in	mm	M	M <sup>3</sup> /min	M	M <sup>3</sup> /min	mm <sup>2</sup> xM	GP	TOS			
	GP-1B12	GPA-1B12	TOS-32-GP	1	1.1			1	200~240	1	32	15	0.19	15	0.15	3.5 <sup>2</sup> x10	31	18.2			
	GP-1B32		TOS-32-GP	1/2				3	200~480	1/4"							30				
	GP-212	GPA-212	TOS-32-GP	2	15			1	200~240	1	32	22	0.2	23	0.19	3.5 <sup>2</sup> x10	37	18.2			
	GP-232		TOS-32-GP					3	200~480	1/4"							34				
	GP-332		TOS-50-GP	3	22			3	200~480	2"	50	21	0.40	22	0.36	3.5 <sup>2</sup> x10	48	18			
	GP-532		TOS-50-GP	5	3.7			3	200~480	2"	50	28	0.43	30	0.40	3.5 <sup>2</sup> x10	50	18			

### PERFORMANCE CURVES:

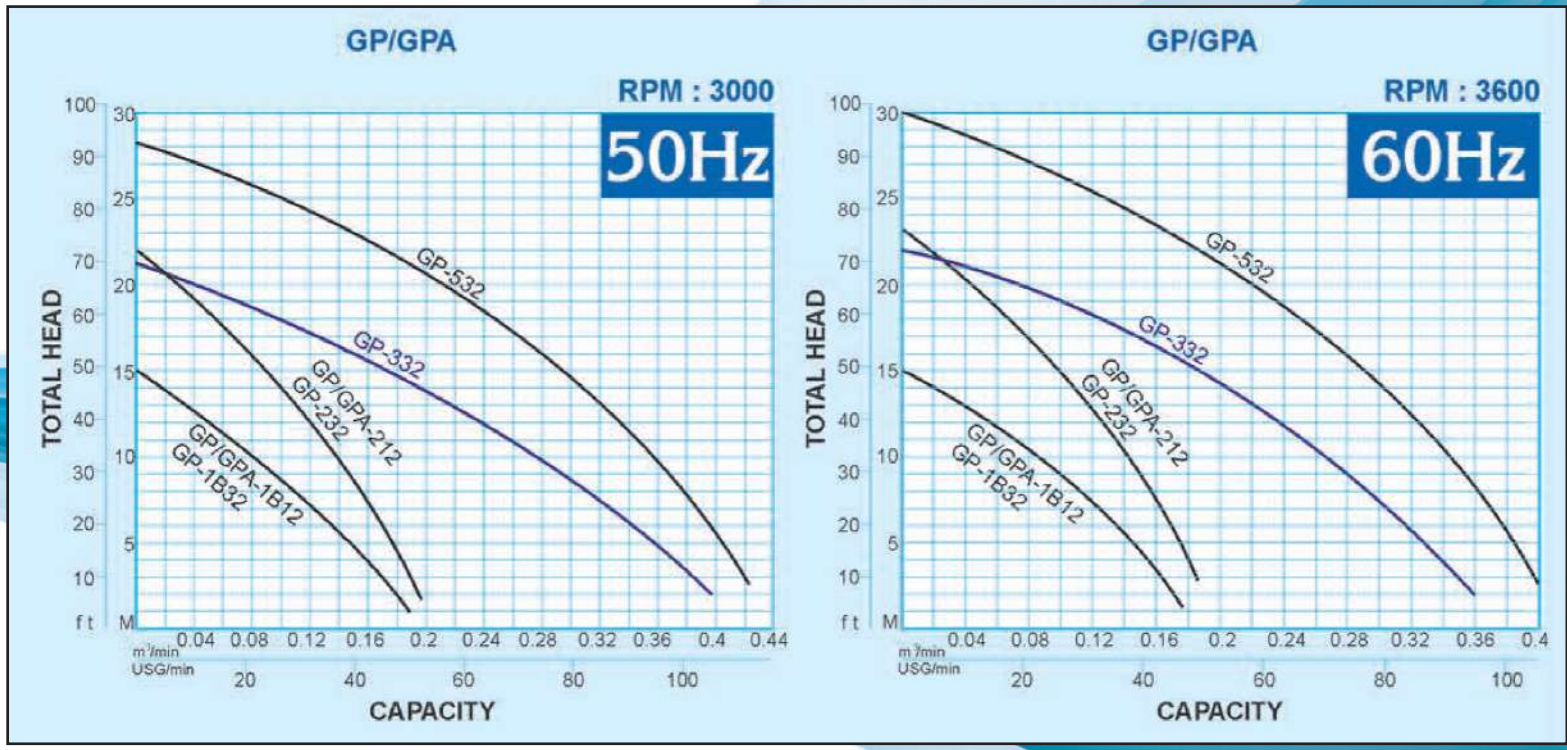



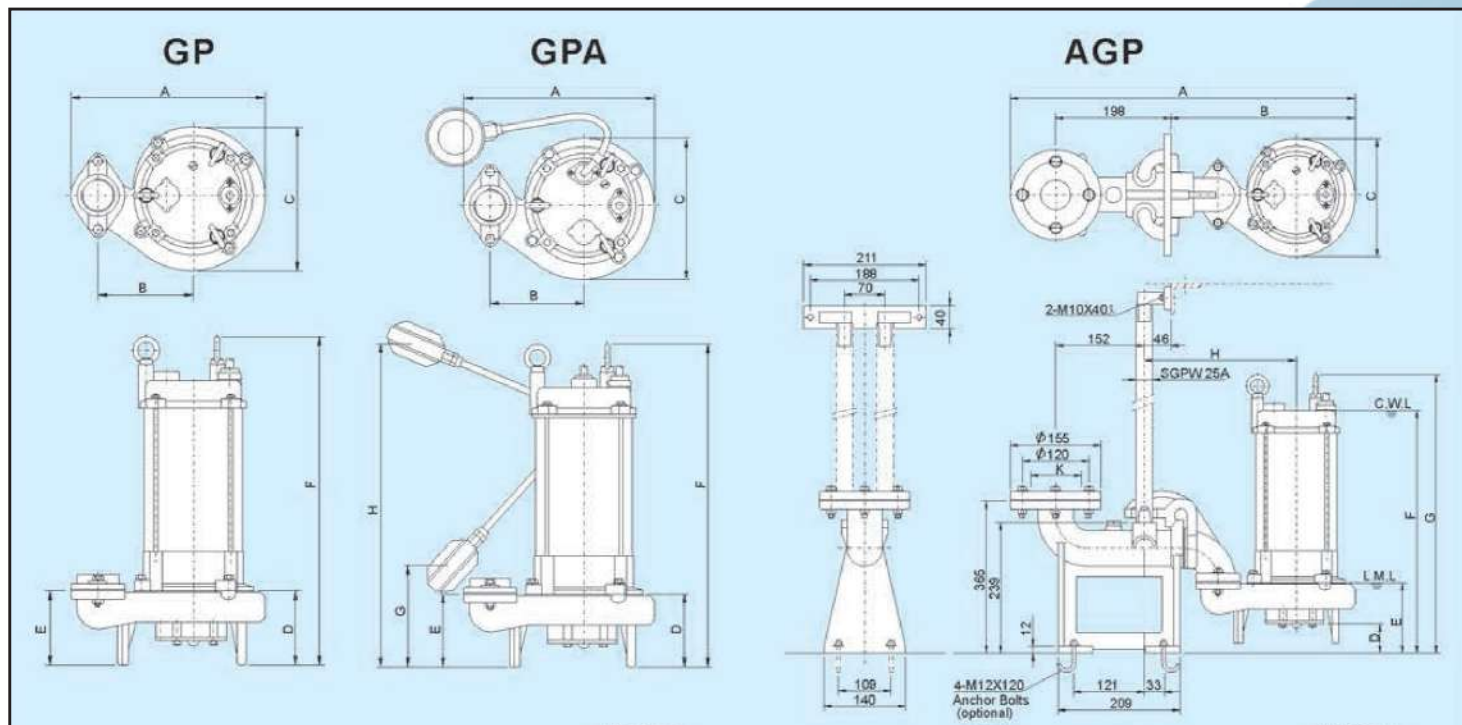

## DIMENSIONS:

TYPE	A		B		C		D		E		F		G		H	
	MM	IN	MM	IN	MM	IN	MM	IN	MM	IN	MM	IN	MM	IN	MM	IN
GP/GPA-1B12	284	11,36	139	5,56	210	8,4	108	4,32	108	4,32	512	20,48	170	6,8	660	26,4
GP-1B32	284	11,36	139	5,56	210	8,4	108	4,32	108	4,32	459	18,36				
GP/GPA-212	284	11,36	139	5,56	210	8,4	108	4,32	108	4,32	552	22,08	170	6,8	700	28
GP-232	284	11,36	139	5,56	210	8,4	108	4,32	108	4,32	459	18,36				
GP-332	312	12,48	155	6,2	234	9,36	111	4,44	111	4,44	513	20,52				
GP-532	312	12,48	155	6,2	234	9,36	111	4,44	111	4,44	573	22,92				

TYPE	A		B		C		D		E		F		G		H		K	
	MM	IN	MM	IN	MM	IN	MM	IN	MM	IN	MM	IN	MM	IN	MM	IN	MM	IN
AGP-1B12	616	24,64	340	13,6	210	8,4	65	2,6	138	5,52	522	20,88	542	21,68	281	11,24	ø32	ø1,28
AGP-1B32	616	24,64	340	13,6	210	8,4	65	2,6	138	5,52	466	18,64	489	19,56	281	11,24	ø32	ø1,28
AGP-212	616	24,64	340	13,6	210	8,4	65	2,6	138	5,52	562	22,48	582	23,28	281	11,24	ø32	ø1,28
AGP-232	616	24,64	340	13,6	210	8,4	65	2,6	138	5,52	466	18,64	489	19,56	281	11,24	ø32	ø1,28
AGP-332	645	25,8	369	14,76	234	9,36	58	2,32	138	5,52	515	20,6	540	21,6	297	11,88	ø50	ø2
AGP-532	645	25,8	369	14,76	234	9,36	53	2,12	138	5,52	566	22,64	600	24	297	11,88	ø50	ø2





# SEWAGE GRINDER PUMPS

## CONSTRUCTIONS:

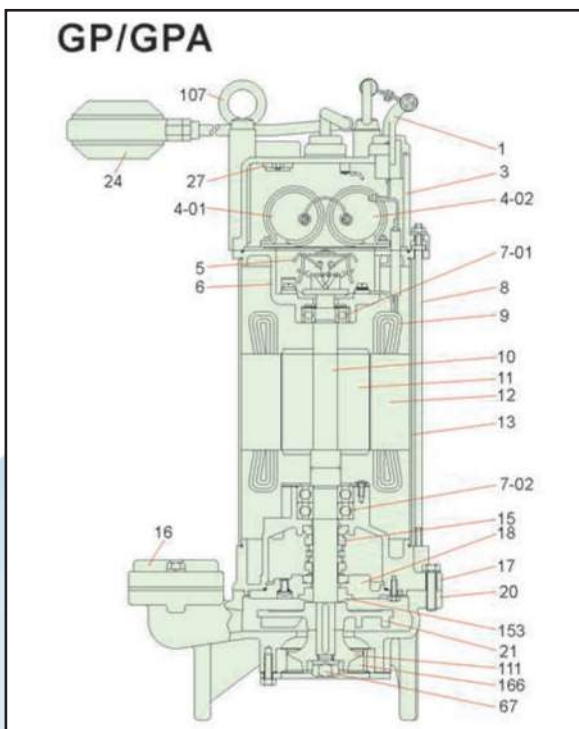
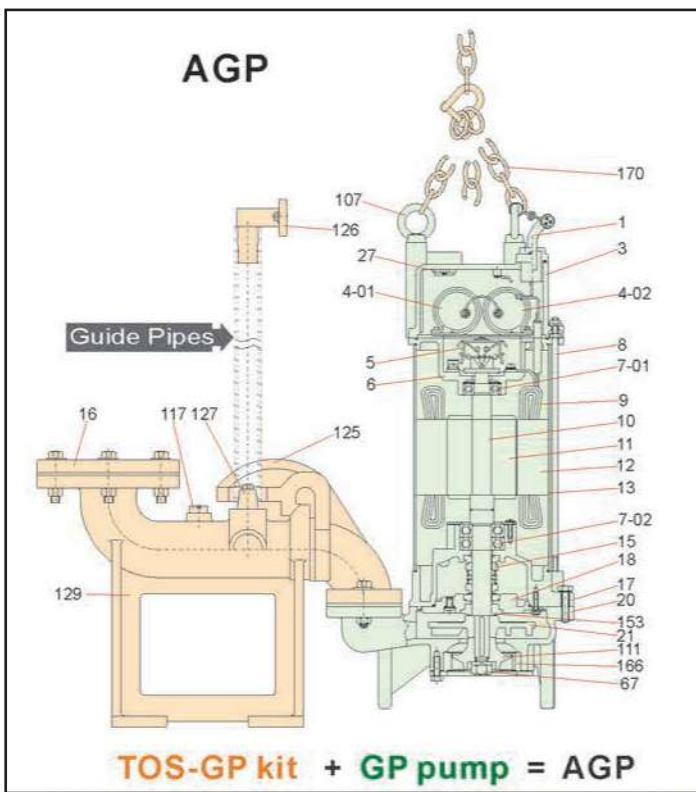

### STANDARD ACCESSORIES OF TOS-GP KIT:

Part NO.	Description/ Discharge bore	1-1/4" (32mm)	2" (50mm)	Material
126	Upper guide support	1.5 kg	1.5 kg	Cast iron
54	Guide Connector	2.7 kg	2.7 kg	Cast iron
97	Lifting chain with shackle	4 m	4 m	SUS 304
129	Duck Foot Bend	12kg	12kg	Cast iron

\*The guide pipes are not included in the package of guide rail kit.

### SPECIFICATION OF GUIDE RAIL KIT, TOS-GP

TYPE	Discharge Bore	Designed for	Weight
TOS-32-GP	1-1/4" (32 mm)	GP-1B12/1B32/212/232	18.2 kG (40,12 LBS)
TOS-80-SSM	2" (50 mm)	GP-332, GP-532	18 kG (39,68 LBS)

Customer can order TOS-GP kit to convert GP pump into AGP.

For example: GP-1B12+ TOS-32-GP = AGP-1B12  
 GP-532 +TOS-50-GP = AGP-532

NO.	NAME OF PARTS	MATERIAL	
		GP/GPA	AGP
1	Cable	V.C.T.	V.C.T.
3	Motor head cover	Cast iron	Cast iron
4-01	Running capacitor		
4-02	Starting capacitor		
5	Centrifugal switch		
6	Upper bracket	Cast iron	Cast iron
7-01	Bearing		
7-02	Bearing	SUS 304	SUS 304
8	Bolt	SUS 304	SUS 304
9	Coil		
10	Shaft	SUS 304	SUS 304
11	Rotor	Steel plate	Steel plate
12	Stator	Steel plate	Steel plate
13	Motor casing	SUS 304	SUS 304
15	Mechanical seal	Ceramic + Carbon	
16	Flange setter	Cast iron	Cast iron
17	Motor lower cover	Cast iron	Cast iron
18	Mechanical seal cover	Cast iron	Cast iron
20	Pump casing	Cast iron	Cast iron
21	Impeller	Cast iron	Cast iron
24	Float Switch	fo GPA only	
27	Thermal protector		
67	Nut	SUS304	SUS304
107	Eye Bolt	SUS304	SUS304
111	Grinder	SCM 440	SCM 440
117	Vented Screw		P. Steel
125	Guide connector		Cast iron
126	Upper guide support		Cast iron
127	Lower guide support		Cast iron
129	Duck foot bend		Cast iron
153	Sand proof trap	NBR	NBR
166	Fixed blade	SCM 440	SCM 440
170	Lifting chain set		SUS 304



# GPO type Submersible Stainless Grinder Pump





**FEATURES:**

1.The powerful integrated grinding mechanism particularly for grinding larger and heavier piece such as the poultry bones at the waste of the restaurant or the untreated sewage with larger hard solid inside.

2.The hard stainless steel made grinder and Impeller together with the high torque motor perform the optimal grinding performance.

3.Special servicing hole situated at the side of the pump casing provide the easy checking and cleaning function during the maintenance.

4.The triplex seals- Double mechanical seal plus an oil seal to isolate the motor from the sewage.

5.Unique Epoxy Cable Sealing Base ensures 100% capability to block the water vapor from entering the motor even the cable breaks.

6.Equipped with a self-reset circle thermal protect or to prevent over-loading, locking of the impeller, and scorch damage to the motor from phase failure.

7.Using dual ball bearing on the bottom of the motor to support the axial push.

**Poultry bones**





# STAINLESS GRINDER PUMPS

## GPQ Series Stainless Grinder Pump

### SPECIFICATIONS:

✓	TYPE	MOTOR					Disch. Diam.		50Hz		60 Hz		Cable	Weight		
		Power		Amp.		Phase			Volt	Max head	Max-Flow	Max head		Max-Flow	mm <sup>2</sup> xM	KG
	GP	HP	KW	Start	Run	PH	V	in	mm	M	M <sup>3</sup> /min	M	M <sup>3</sup> /min			
	<b>GPQ-732</b>	7 1/2	5.5			3	200~480	3"	80	13	1.25	15	1.28	5.5 <sup>2</sup> x10	83.5	184,09

### PERFORMANCE CURVES:

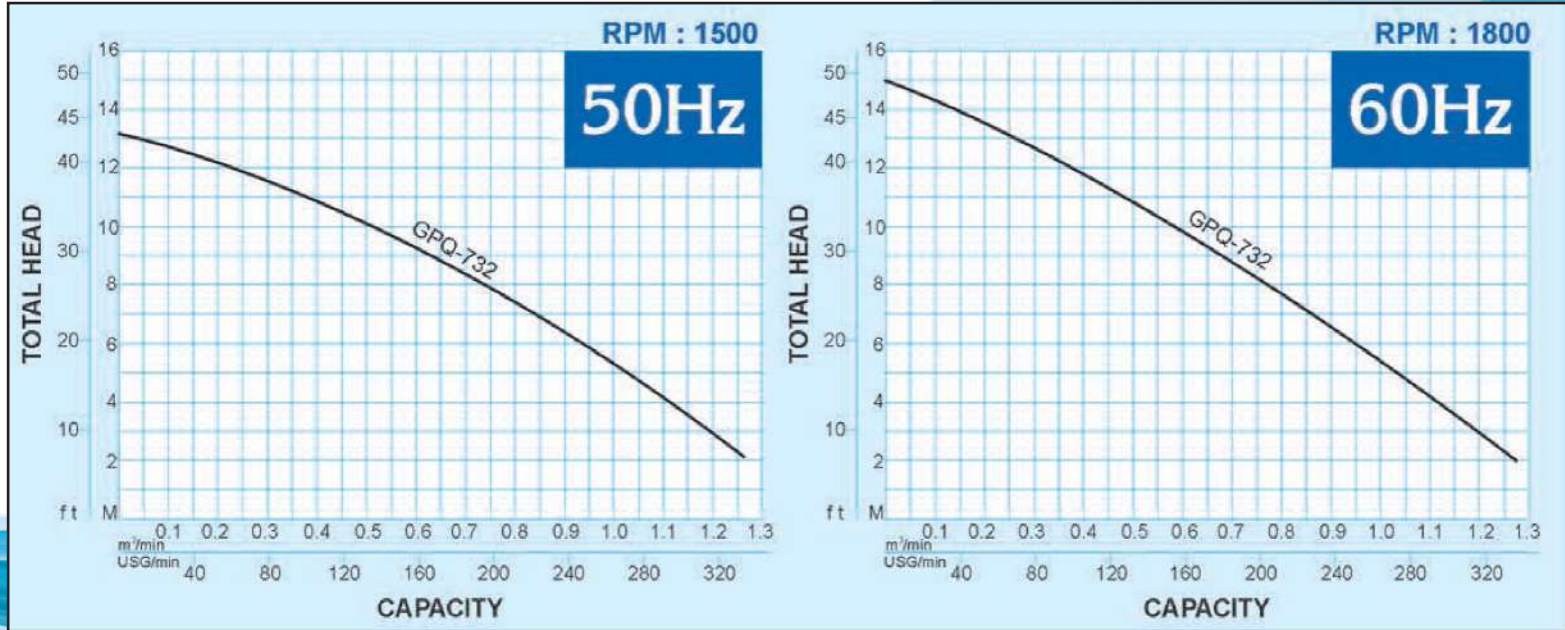

### DIMENSIONS:

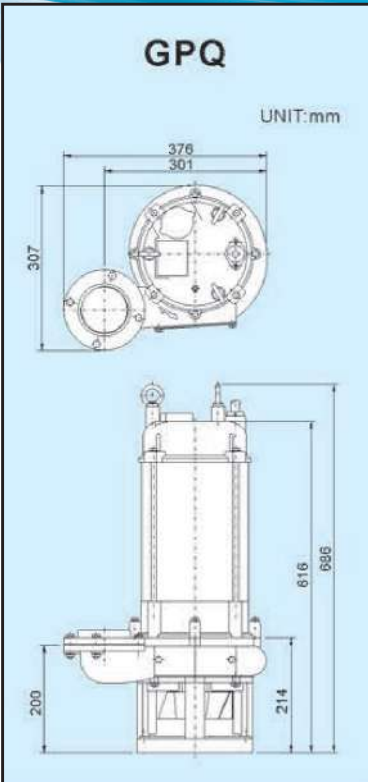

### CONSTRUCTIONS:

NO.	NAME OF PARTS	MATERIAL
1	Cable	V.C.T
3	Motor head cover	SUS 304
7-01	Bearing	
7-02	Bearing	
8	Bolt	SUS 304
9	Coil	
10	Shaft	SUS 410
11	Rotor	Steel plate
12	Stator	Steel plate
13	Motor casing	SUS 304
15	Mechanical seal	Ceramic+Carbon
16	Flange setter	SUS 304
17	Motor low cover	SUS 304
18	Mechanical seal cover	SUS 304
19	Oil seal	NBR
20	Pump casing	SUS 304
21	Impeller	SUS 304
22	Suction cover	SUS 304
27	Thermal protector	
68	Nut	Gun metal
90	Motor base	SUS 304
111	Grinder	SUS 304



# SUBMERSIBLES PUMPS

## ● Accessories

### Control Panel

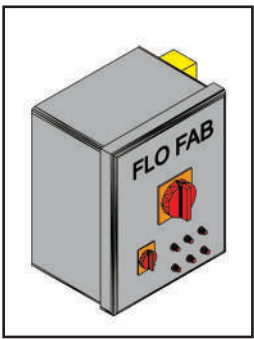

FLO FAB Standard UL or CSA NEMA 1 — enclosure. Includes main disconnect switch, internal circuit, breakers, transformer, low suction pressure switch and pilot light, hand-off auto switch, pump running light, current-relay, minimum run timer, automatic transfer to lag pump circuit, lead pump selector switch, power on light, dry contact for remote signal.

Model

- Simplex
- Duplex
- Triplex
- SSP
- DSP
- TSP
- 115/1
- 230/1
- 575/3
- 208/3
- 460/3
- 575/3

### Tank Alert Float

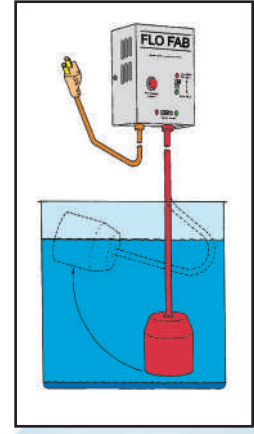

- Nema 1 Compliance in a metal alarm panel
- When used with a pump application, the Tank Alert may be connected to a circuit breaker other than the pump circuit. This allows the Tank Alert to operate even if the pump circuit should fail.

Model

- 101 HW
  - 101 LW
  - With Dry Contact
  - Without Dry Contact
- 120/1/60**

### Mechanical Float Switch

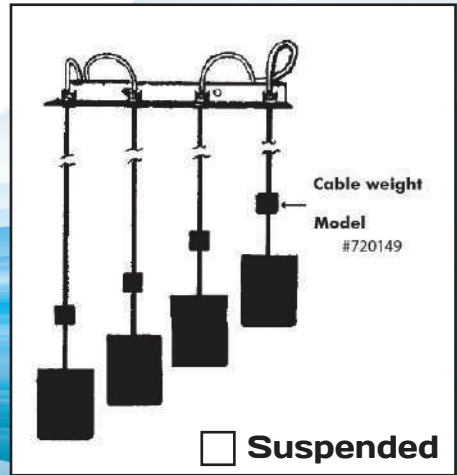
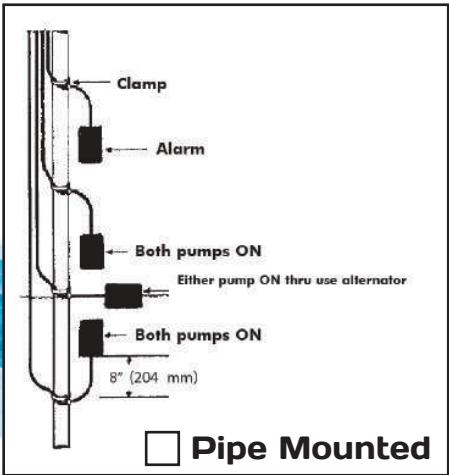

#720145 Bracket

- Not Included
- Included

Model

Contacts

- 30 720165
- with Plug
- without Plug

QTY. \_\_\_\_\_

### General arrangement for Single Pump float operation (plug in type)

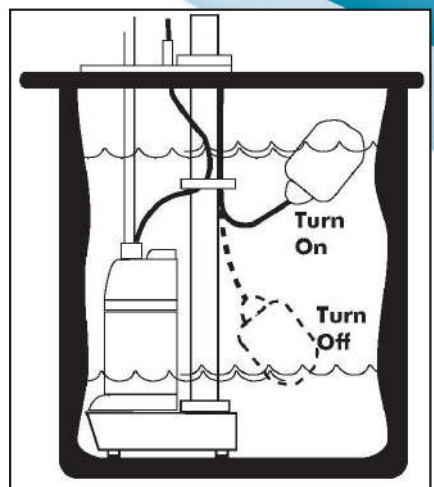
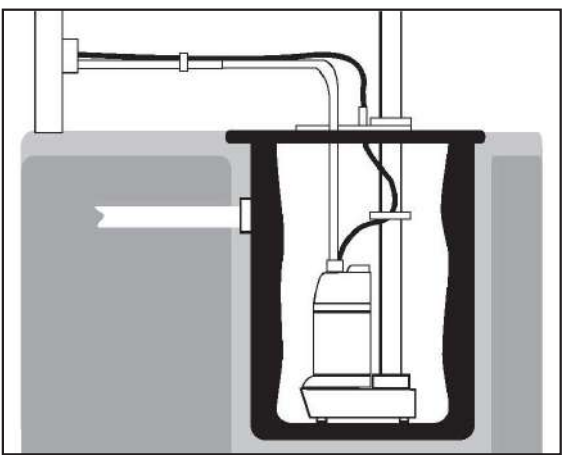

Float Model

Contacts

- 30" 720165
- N/O

QTY. \_\_\_\_\_





Polyethylene Basin

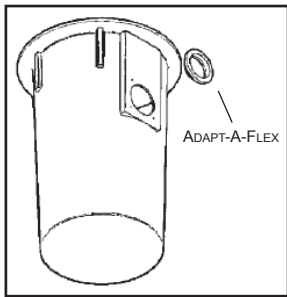

- Polyethylene
  - Fiberglass
- Model
- 1830 - 30 gal.
  - 2436 - 70 gal.
  - 3636 - 159 gal.
  - 4848 - 376 gal.

Steel Basin Covers

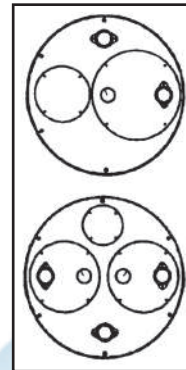

- Simplex
- Duplex

Model

- 18"
- 24"
- 36"
- 48"

Check Valve

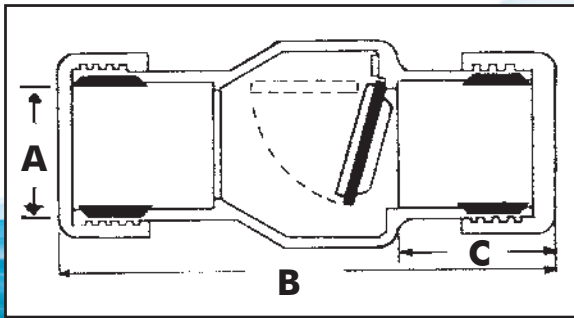

Type CVP

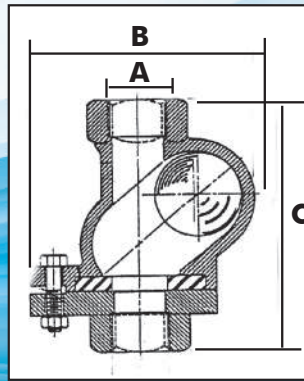

Type CBO125-CBO200

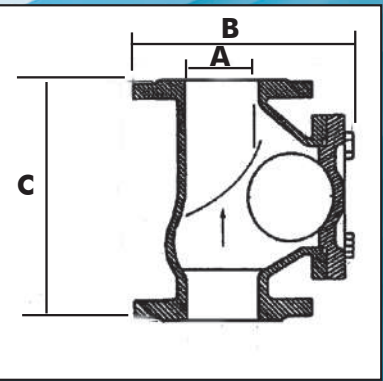

Type CBO300-CBO400

√	Models	A	B		C		Pressure Test lb/po/ca
			mm	in	mm	in	
	<b>CVP0125</b>	1 1/4" NPT	132	5 1/4	28	1 1/8	
	<b>CVP0150</b>	1 1/2" NPT	132	5 1/4	28	1 1/8	
	<b>CVP0200</b>	2" NPT	245	9 3/4	70	2 3/4	
	<b>CVP0300</b>	3" NPT	350	14	100	4	
	<b>CB0125</b>	1 1/4" NPT	119	4 11/16	135	5 5/16	150
	<b>CB0150</b>	1 1/2" NPT	119	4 11/16	135	5 5/16	150
	<b>CB0200</b>	2" NPT	157	6 3/16	175	6 7/8	150
	<b>CB0300</b>	3" Flanged	214	8 7/16	246	9 1/16	150
	<b>CB0400</b>	4" Flanged	282	11 1/8	300	11 3/16	150





## ● Slide Away Coupling :

### FBV - 3" & 4"

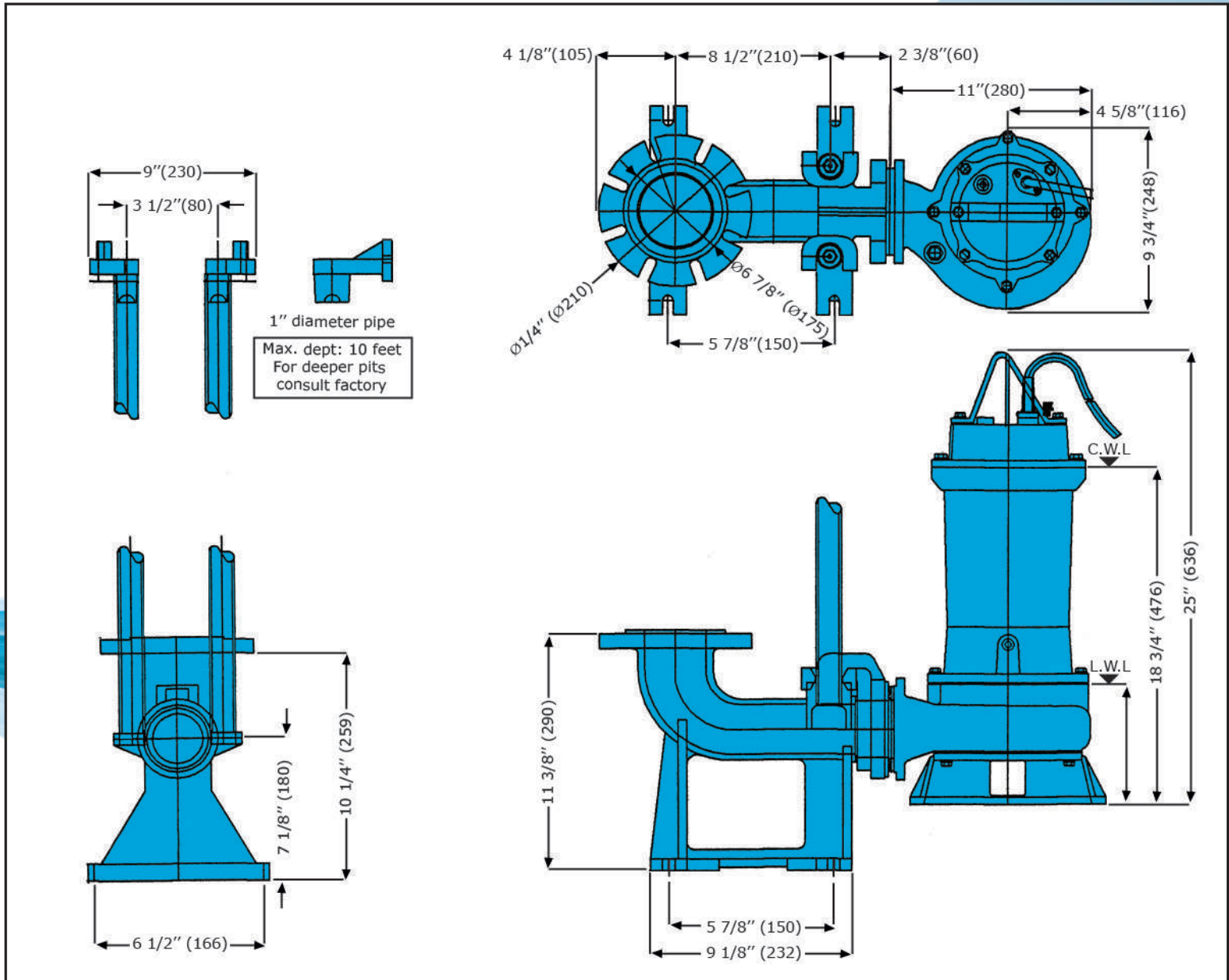

FBV - 3" Model BAF O300

FBV - 4" Model BAF O400



● **Slide Away Coupling :**

**FS 3" & 4"**

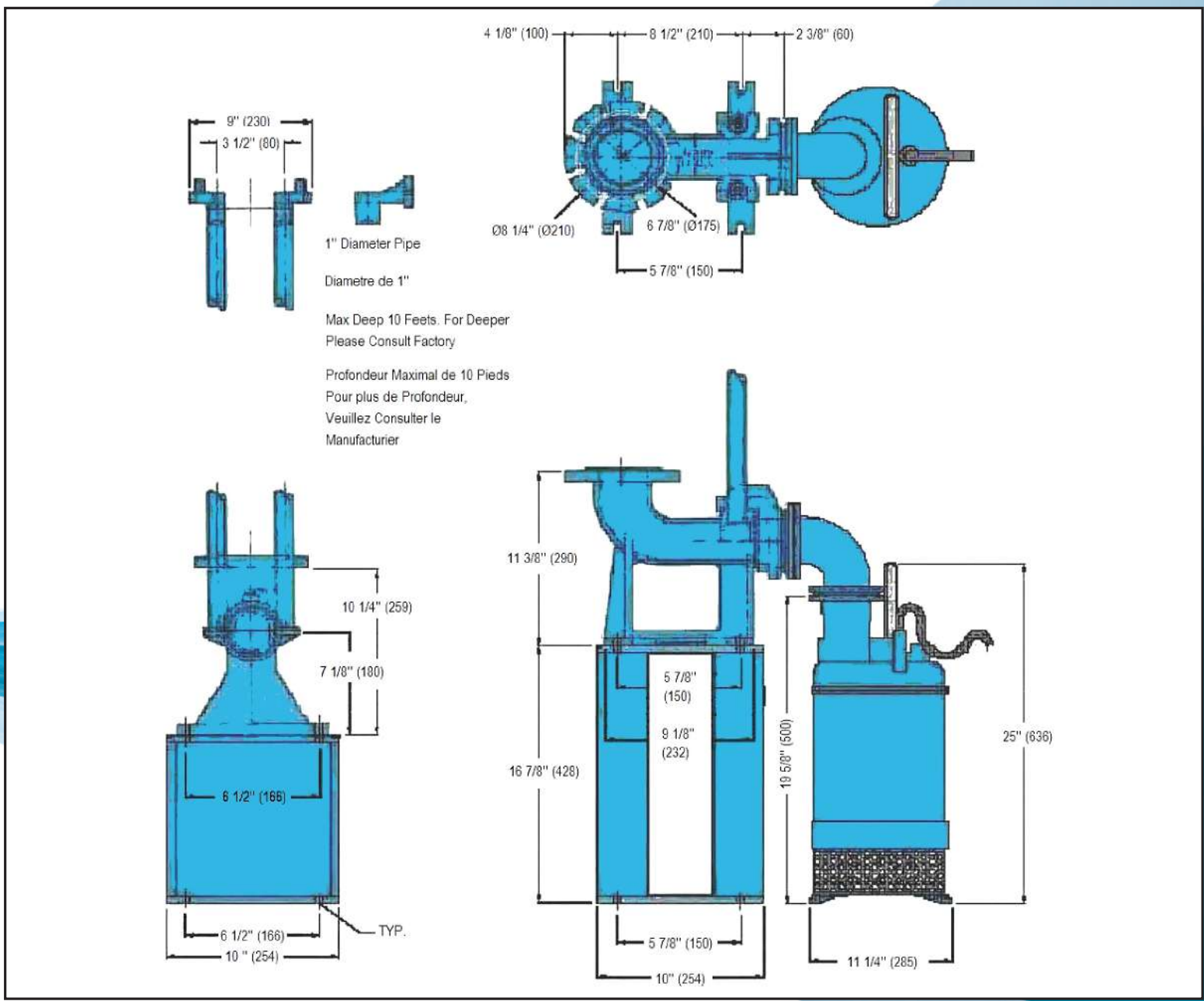

- FS - 3" Model BAFFSO300**
- FS - 4" Model BAFFSO400**





## 18" Fiberglass Basins



√	Models	DIA X DEPTH	CAPACITY	WEIGHT
	<b>1822FB-LC</b>	18 X 22	24	12
	<b>1830FB-LC</b>	18 X 30	33	15
	<b>1836FB-LC</b>	18 X 36	40	18
	<b>1842FB-LC</b>	18 X 42	46	21
	<b>1848FB-LC</b>	18 X 48	53	24
	<b>1854FB-LC</b>	18 X 54	59	27
	<b>1860FB-LC</b>	18 X 60	66	30
	<b>1866FB-LC</b>	18 X 66	73	33
	<b>1872FB-LC</b>	18 X 72	79	36
	<b>1878FB-LC</b>	18 X 78	86	39
	<b>1884FB-LC</b>	18 X 84	93	42
	<b>1890FB-LC</b>	18 X 90	99	45
	<b>1896FB-LC</b>	18 X 96	106	48

Suitable for liquids up to 140°F  
 Cover not included in basin price See below  
 Adapt-a-flex and cast iron hubs sold separately

**Longer Depths Available**  
**Basins 48" and Deeper c/w Anti-Float**  
**If Anti-Float not required please call for P & D**

## Covers for 18" Dia. Basins

BLANK  
Steel / S. foam



BLANK / steel  
Checker Plated



SIMPLEX  
Steel / SF (1pc)



SIMPLEX 2 PC  
Structural foam



√	Models	MATERIAL	WEIGHT
	<b>18B</b>	BLANK STEEL 3/16" THICK	14
	<b>18BCP</b>	BLANK STEEL checker plated	14
	<b>18BSF</b>	BLANK STRUCTURAL FOAM	5

√	Models	MATERIAL	WEIGHT
	<b>18SSF*</b>	SIMPLEX SF (1pc)	7
	<b>SF114-2PC*</b>	SIMPLEX SPLIT 2 PC FOAM	10
	<b>18S*</b>	SIMPLEX STEEL 3/16" THICK	10

\*c/w 2" discharge & 3" vent flanges



## 24" Fiberglass Basins



✓	Models	DIA X DEPTH	CAPACITY	WEIGHT
	<b>2424FB-LC</b>	24 X 24	47	30
	<b>2430FB-LC</b>	24 X 30	59	35
	<b>2436FB-LC</b>	24 X 36	70	40
	<b>2442FB-LC</b>	24 X 42	82	45
	<b>2448FB-LC</b>	24 X 48	94	50
	<b>2454FB-LC</b>	24 X 54	106	54
	<b>2460FB-LC</b>	24 X 60	117	59
	<b>2466FB-LC</b>	24 X 66	129	64
	<b>2472FB-LC</b>	24 X 72	141	69
	<b>2478FB-LC</b>	24 X 78	153	92
	<b>2484FB-LC</b>	24 X 84	164	96
	<b>2490FB-LC</b>	24 X 90	176	100
	<b>2496FB-LC</b>	24 X 96	188	105

Suitable for liquids up to 140°F  
 Cover not included in basin price See below  
 Adapt-a-flex and cast iron hubs sold separately

**Longer Depths Available**  
**Basins 48" and Deeper c/w Anti-Float**  
**If Anti-Float not required please call for P & D**

## Covers for 24" Dia. Basins

Steel / F/ S Foam

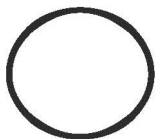

SLIMPLEX SF



SIMPLEX / steel



BLANK / steel  
 Checker Plated



DUPLEX  
 Structural foam

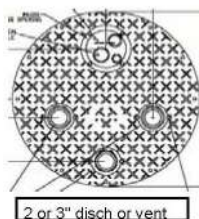

✓	Models	MATERIAL	WEIGHT
	<b>24B</b>	BLANK STEEL 3/16" THICK	48
	<b>24BCP</b>	BLANK STEEL checker plated	48
	<b>24BF</b>	BLANK FIBERGLASS	18
	<b>SF24B-BL</b>	BLANK STUCTURAL FOAM	20
	<b>SF24S-BL*</b>	SIMPLEX STUCTURAL FOAM	22
	<b>LB-10-S2401-1</b>	SIMPLEX STEEL 10 gauge	
	<b>24SI</b>	SIMPLEX STEEL 3/16" THICK	50
	<b>SF24D-BL*</b>	DUPLEX STUCTURAL FOAM	24
	<b>JC24H</b>	3/16" STEEL HINGED DOOR COVER	

\*c/w 2" discharge & 3" vent flanges



## 30" Fiberglass Basins



√	Models	DIA X DEPTH	CAPACITY	WEIGHT
	<b>3030FB-LC</b>	30 X 30	92	46
	<b>3036FB-LC</b>	30 X 36	110	52
	<b>3042FB-LC</b>	30 X 42	129	58
	<b>3048FB-LC</b>	30 X 48	147	64
	<b>3054FB-LC</b>	30 X 54	165	70
	<b>3060FB-LC</b>	30 X 60	184	76
	<b>3066FB-LC</b>	30 X 66	202	112
	<b>3072FB-LC</b>	30 X 72	220	118
	<b>3078FB-LC</b>	30 X 78	239	125
	<b>3084FB-LC</b>	30 X 84	257	133
	<b>3090FB-LC</b>	30 X 90	275	141
	<b>3096FB-LC</b>	30 X 96	294	148

Suitable for liquids up to 140°F  
 Cover not included in basin price See below  
 Adapt-a-flex and cast iron hubs sold separately

**Longer Depths Available**  
**Basins 48" and Deeper c/w Anti-Float**  
**If Anti-Float not required please call for P & D**

## Covers for 30" Dia. Basins

BLANK  
Steel / Fiberglass



BLANK / steel  
Checker Plated



SIMPLEX W/ INSP  
Steel only



DUPLEX W/ INSP  
Steel / Fiberglass



√	Models	MATERIAL	WEIGHT
	<b>30B</b>	BLANK STEEL 3/16" THICK	65
	<b>30BCP</b>	BLANK STEEL checker plated	65
	<b>30BF</b>	BLANK FIBERGLASS	20
	<b>LB-10S3001</b>	SIMPLEX STEEL 10 gauge	
	<b>30SI*</b>	SIMPLEX STEEL 3/16" THICK	69
	<b>30DIF*</b>	DUPLEX FIBERGLASS	30
	<b>LB-10S3002</b>	DUPLEX STEEL 10 gauge	
	<b>30DI*</b>	DUPLEX STEEL 3/16" THICK	75
	<b>JC30H</b>	3/16" STEEL HINGED DOOR COVER	

\*c/w 2" discharge & 3" vent flanges





## 36" Fiberglass Basins



√	Models	DIA X DEPTH	CAPACITY	WEIGHT
	<b>3636FB-LC</b>	36 X 36	159	65
	<b>3642FB-LC</b>	36 X 42	185	71
	<b>3648FB-LC</b>	36 X 48	211	78
	<b>3654FB-LC</b>	36 X 54	238	86
	<b>3660FB-LC</b>	36 X 60	264	93
	<b>3666FB-LC</b>	36 X 66	291	159
	<b>3672FB-LC</b>	36 X 72	317	168
	<b>3678FB-LC</b>	36 X 78	344	177
	<b>3684FB-LC</b>	36 X 84	370	186
	<b>3690FB-LC</b>	36 X 90	397	196
	<b>3696FB-LC</b>	36 X 96	423	205

Suitable for liquids up to 140°F  
 Cover not included in basin price See below  
 Adapt-a-flex and cast iron hubs sold separately

**Longer Depths Available**  
**Basins 48" and Deeper c/w Anti-Float**  
**If Anti-Float not required please call for P & D**

## Covers for 36" Dia. Basins

BLANK  
Steel / Fiberglass



SIMPLEX W/ INSP  
Steel only



BLANK / steel  
Checker Plated



DUPLEX W/ INSP  
Steel / Fiberglass



√	Models	MATERIAL	WEIGHT
	<b>36B</b>	BLANK STEEL 3/16" THICK	90
	<b>36BCP</b>	BLANK STEEL checker plated	90
	<b>36BF</b>	BLANK FIBERGLASS	30
	<b>LB-10S3601</b>	SIMPLEX STEEL 10 gauge	
	<b>36SI*</b>	SIMPLEX STEEL 3/16" THICK	95
	<b>LB-10S3602</b>	DUPLEX STEEL 10 gauge	
	<b>36DI*</b>	DUPLEX STEEL 3/16" THICK	110
	<b>JC36H</b>	1/4" STEEL HINGED DOOR COVER	

\*c/w 2" discharge & 3" vent flanges



## 42" Fiberglass Basins



√	Models	DIA X DEPTH	CAPACITY	WEIGHT
	<b>4230FB-LC</b>	42 X 30	180	81
	<b>4236FB-LC</b>	42 X 36	216	94
	<b>4242FB-LC</b>	42 X 42	252	105
	<b>4248FB-LC</b>	42 X 48	288	116
	<b>4254FB-LC</b>	42 X 54	324	128
	<b>4260FB-LC</b>	42 X 60	360	139
	<b>4266FB-LC</b>	42 X 66	396	183
	<b>4272FB-LC</b>	42 X 72	432	194
	<b>4278FB-LC</b>	42 X 78	468	208
	<b>4284FB-LC</b>	42 X 84	504	221
	<b>4290FB-LC</b>	42 X 90	540	235
	<b>4296FB-LC</b>	42 X 96	576	249

Suitable for liquids up to 140°F  
 Cover not included in basin price See below  
 Adapt-a-flex and cast iron hubs sold separately

**Longer Depths Available**  
**Basins 48" and Deeper c/w Anti-Float**  
**If Anti-Float not required please call for P & D**

## Covers for 42" Dia. Basins

BLANK  
Steel / Fiberglass

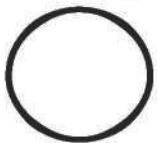

Simplex Steel

BLANK / steel  
Checker Plated



Duplex Steel



√	Models	MATERIAL	WEIGHT
	<b>42B</b>	BLANK STEEL 3/16" THICK	128
	<b>42BCP</b>	BLANK STEEL checker plated	128
	<b>42BF</b>	BLANK FIBERGLASS	40
	<b>42SI*</b>	SIMPLEX STEEL 1/4" THICK	135
	<b>42DI*</b>	DUPLEX STEEL 1/4" THICK	140
	<b>LB-S42HDC</b>	1/4" STEEL HINGED DOOR COVER	

\*c/w 2" discharge & 3" vent flanges



## 48" Fiberglass Basins



✓	Models	DIA X DEPTH	CAPACITY	WEIGHT
	<b>4830FB-LC</b>	48 X 30	235	97
	<b>4836FB-LC</b>	48 X 36	282	110
	<b>4842FB-LC</b>	48 X 42	329	123
	<b>4848FB-LC</b>	48 X 48	376	136
	<b>4854FB-LC</b>	48 X 54	423	148
	<b>4860FB-LC</b>	48 X 60	470	161
	<b>4866FB-LC</b>	48 X 66	517	244
	<b>4872FB-LC</b>	48 X 72	564	260
	<b>4878FB-LC</b>	48 X 78	611	280
	<b>4884FB-LC</b>	48 X 84	658	299
	<b>4890FB-LC</b>	48 X 90	705	318
	<b>4896FB-LC</b>	48 X 96	752	338

Suitable for liquids up to 140°F  
 Cover not included in basin price See below  
 Adapt-a-flex and cast iron hubs sold separately

**Longer Depths Available**  
**Basins 48" and Deeper c/w Anti-Float**  
**If Anti-Float not required please call for P & D**

## Covers for 48" Dia. Basins

BLANK  
Steel / Fiberglass



SIMPLEX W/ INSF  
Steel only



BLANK / steel  
Checker Plated



DUPLEX W/ INSP  
Steel / Fiberglass

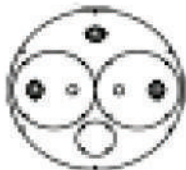

✓	Models	MATERIAL	WEIGHT
	<b>48B</b>	BLANK STEEL 1/4" THICK	165
	<b>48BCP</b>	BLANK STEEL checker plated	165
	<b>48BF</b>	BLANK FIBERGLASS	65
	<b>48SI*</b>	SIMPLEX STEEL 1/4" THICK	170
	<b>48DI*</b>	DUPLEX STEEL 1/4" THICK	180
	<b>JC48H</b>	1/4" STEEL HINGED DOOR COVER	

\*c/w 2" discharge & 3" vent flanges





## 60" Fiberglass Basins



√	Models	DIA X DEPTH	CAPACITY	WEIGHT
	<b>6036FB-LC</b>	60 X 36	440	309
	<b>6042FB-LC</b>	60 X 42	514	334
	<b>6048FB-LC</b>	60 X 48	587	358
	<b>6054FB-LC</b>	60 X 54	661	382
	<b>6060FB-LC</b>	60 X 60	734	406
	<b>6066FB-LC</b>	60 X 66	808	430
	<b>6072FB-LC</b>	60 X 72	881	454
	<b>6078FB-LC</b>	60 X 78	955	483
	<b>6084FB-LC</b>	60 X 84	1028	512
	<b>6090FB-LC</b>	60 X 90	1102	540
	<b>6096FB-LC</b>	60 X 96	1175	569

Suitable for liquids up to 140°F  
 Cover not included in basin price See below  
 Adapt-a-flex and cast iron hubs sold separately

**Longer Depths Available**  
**Basins 48" and Deeper c/w Anti-Float**  
**If Anti-Float not required please call for P & D**

## Covers for 60" Dia. Basins

BLANK  
Steel / Fiberglass

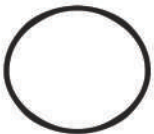

BLANK / steel  
Checker Plated



SIMPLEX W/ INSP  
Steel only



DUPLEX W/ INSP  
Steel / Fiberglass



√	Models	MATERIAL	WEIGHT
	<b>60B</b>	BLANK STEEL 1/4" THICK	365
	<b>60BCP</b>	BLANK STEEL checker plated	365
	<b>60BF</b>	BLANK FIBERGLASS	75
	<b>60SI*</b>	SIMPLEX STEEL 1/4" THICK	380
	<b>60DI*</b>	DUPLEX STEEL 1/4" THICK	395
	<b>LB-S60HDC</b>	3/8" STEEL HINGED DOOR COVER	

\*c/w 2" discharge & 3" vent flanges



**SIMPLEX METAL COVER**

**Simplex Metal Covers**

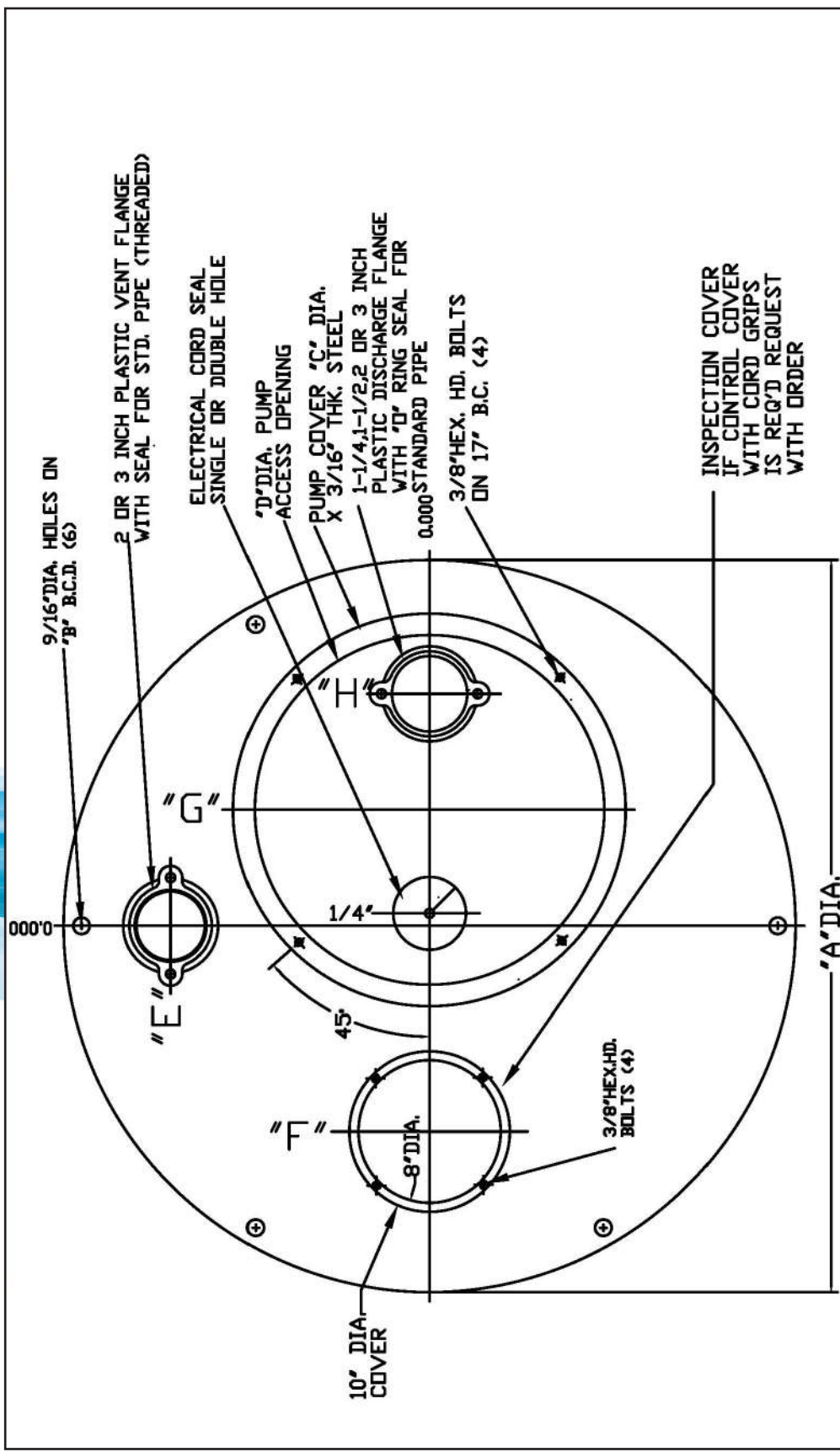

Add to the part number  
 IB - Blank Inspection Cover  
 CC - Control Cover

BASIN DIAMETER	"A" DIA.	THICKNESS	"B" B.C.D.	DIM "C"	DIM "D"	DIM "E"	DIM "F"	DIM "G"	DIM "H"
24"	28.00"	3/16"	26 1/2"	16"	14"	10"	7 3/4"	5 1/2"	8"
30"	34.00"	3/16"	32 1/2"	18"	16"	12 1/8"	9 1/2"	5 1/4"	7 3/4"



# Simplex Metal Covers

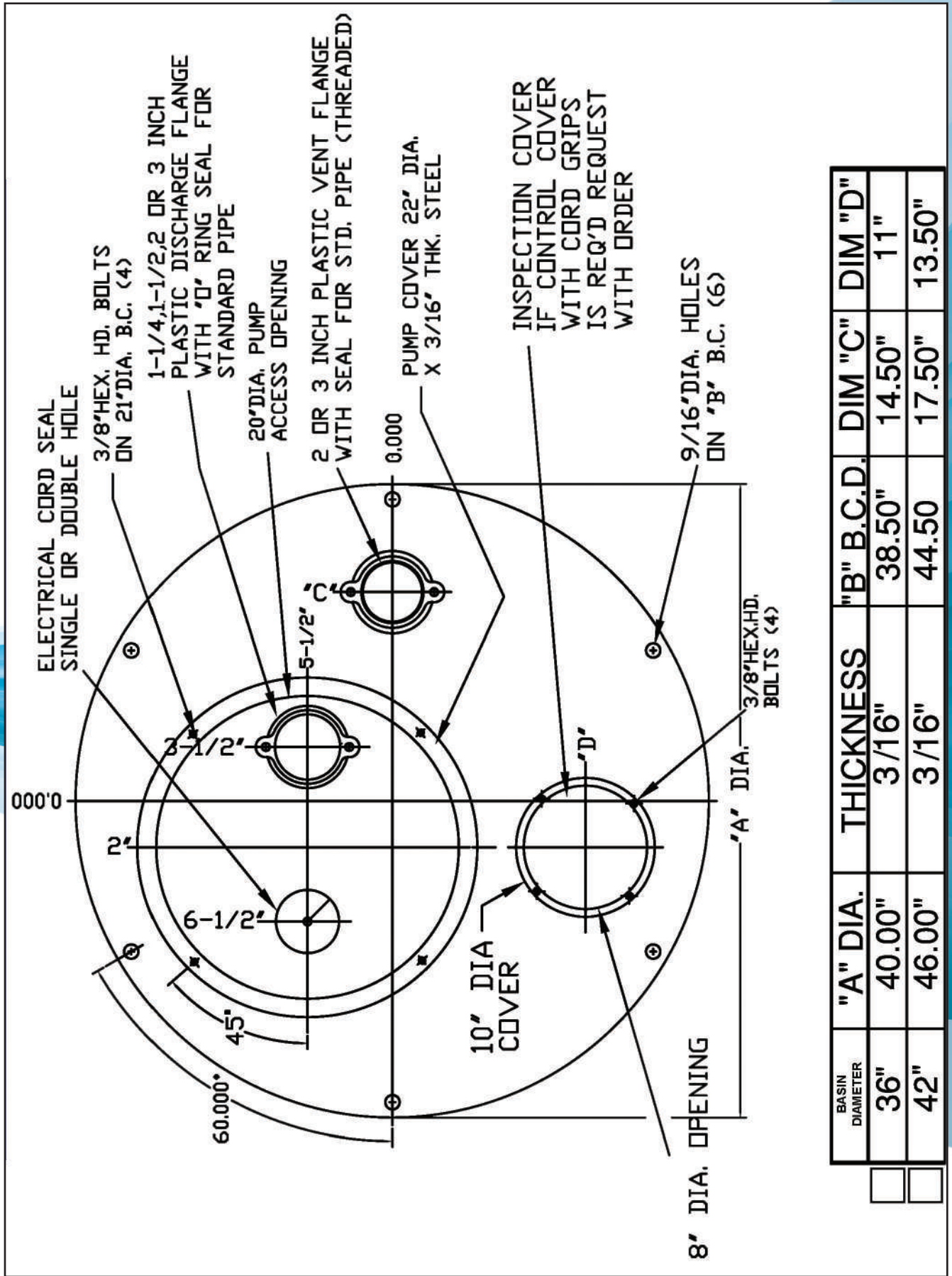

BASIN DIAMETER	"A" DIA.	THICKNESS	"B" B.C.D.	DIM "C"	DIM "D"
36"	40.00"	3/16"	38.50"	14.50"	11"
42"	46.00"	3/16"	44.50"	17.50"	13.50"





# Simplex Metal Covers

2" OR 3" PLASTIC VENT FLANGE WITH "O" RING SEAL FOR STD. PIPE (THREADED)  
 1-1/4", 1-1/2", 2" OR 3" PLASTIC DISCHARGE FLANGE WITH "O" RING SEAL FOR STD. PIPE  
 "C" DIA. PUMP COVER X 3/16" THK. H.R.P.D. STEEL  
 "D" DIA. PUMP ACCESS OPENING  
 9/16" DIA. HOLES ON 51" BOLT CIRCLE (6) PLACES  
 INSPECTION COVER IF CONTROL COVER WITH CORD GRIPS IS REQ'D REQUEST WITH ORDER  
 10" DIA. COVER  
 8" DIA. OPENING  
 3/8"-16 HEX. HD. BOLTS (4)  
 3/8"-16 HEX. HD. BOLTS  
 "A" DIA.  
 "B" B.C.D.  
 "C"  
 "D"  
 "E"  
 "F"  
 "G"  
 "H"  
 50 DEG. TYP.  
 45 DEG.  
 0.000  
 0.000  
 ELECTRICAL CORD SEAL (SINGLE OR DOUBLE HOLE)  
 NO INSPECTION  
 WITH INSPECTION

BASIN DIAMETER	"A" DIA.	THICKNESS	"B" B.C.D.	DIM "C"	DIM "D"	DIM "E"	DIM "F"	DIM "G"	DIM "H"
<input type="checkbox"/> 48"	54"	3/16"	51"	22"	20"	20"	N/A	4 1/2"	5 1/2"
<input type="checkbox"/> 48"	54"	3/16"	51"	22"	20"	20"	17 1/2"	4 1/2"	5 1/2"
<input type="checkbox"/> 60"	66"	3/16"	63"	28"	26"	25 1/2"	N/A	5"	8"
<input type="checkbox"/> 60"	66"	3/16"	63"	28"	26"	25 1/2"	20"	5"	8"

# 24" Duplex Metal Covers

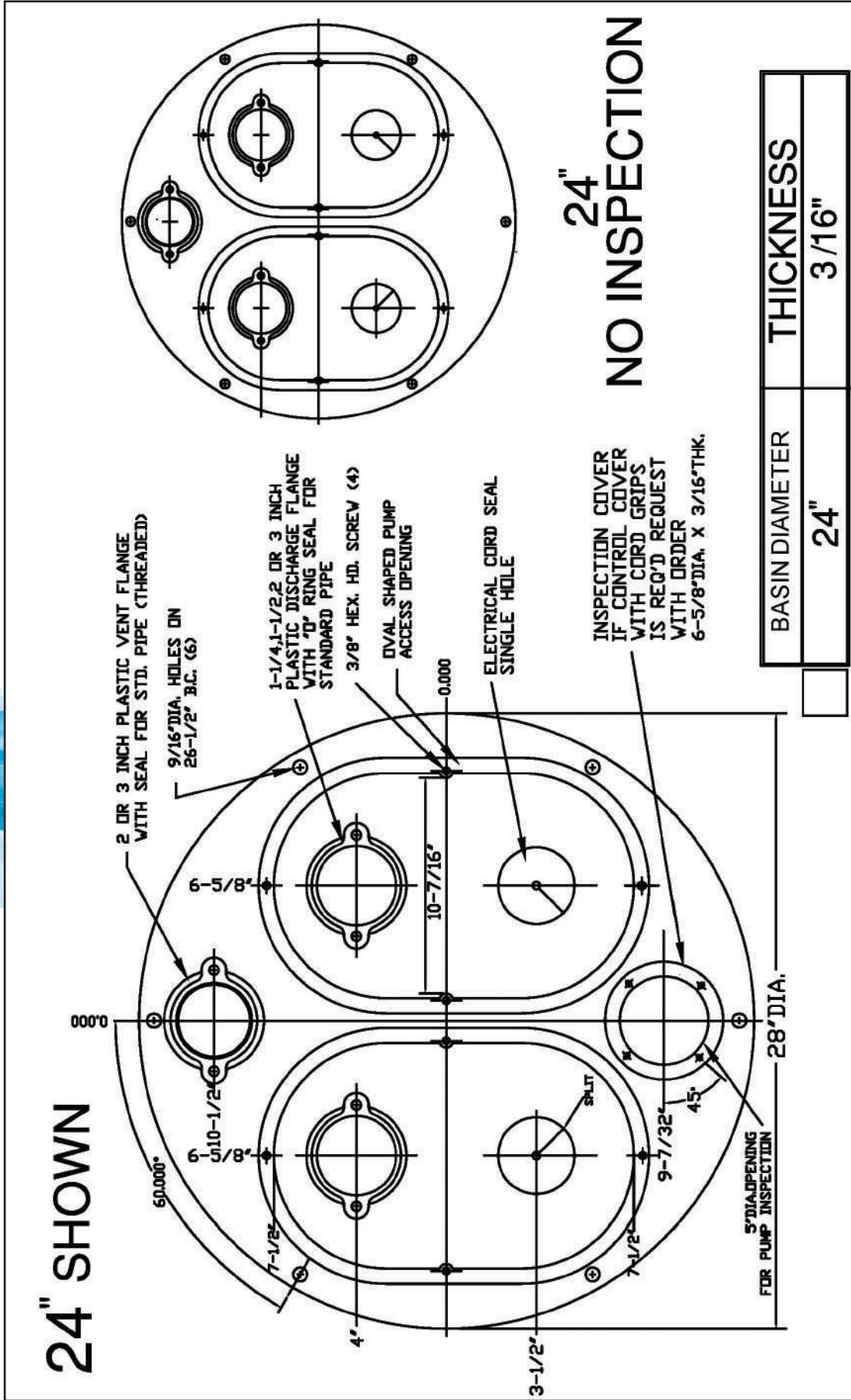



# 30" Fiberglass Duplex Covers

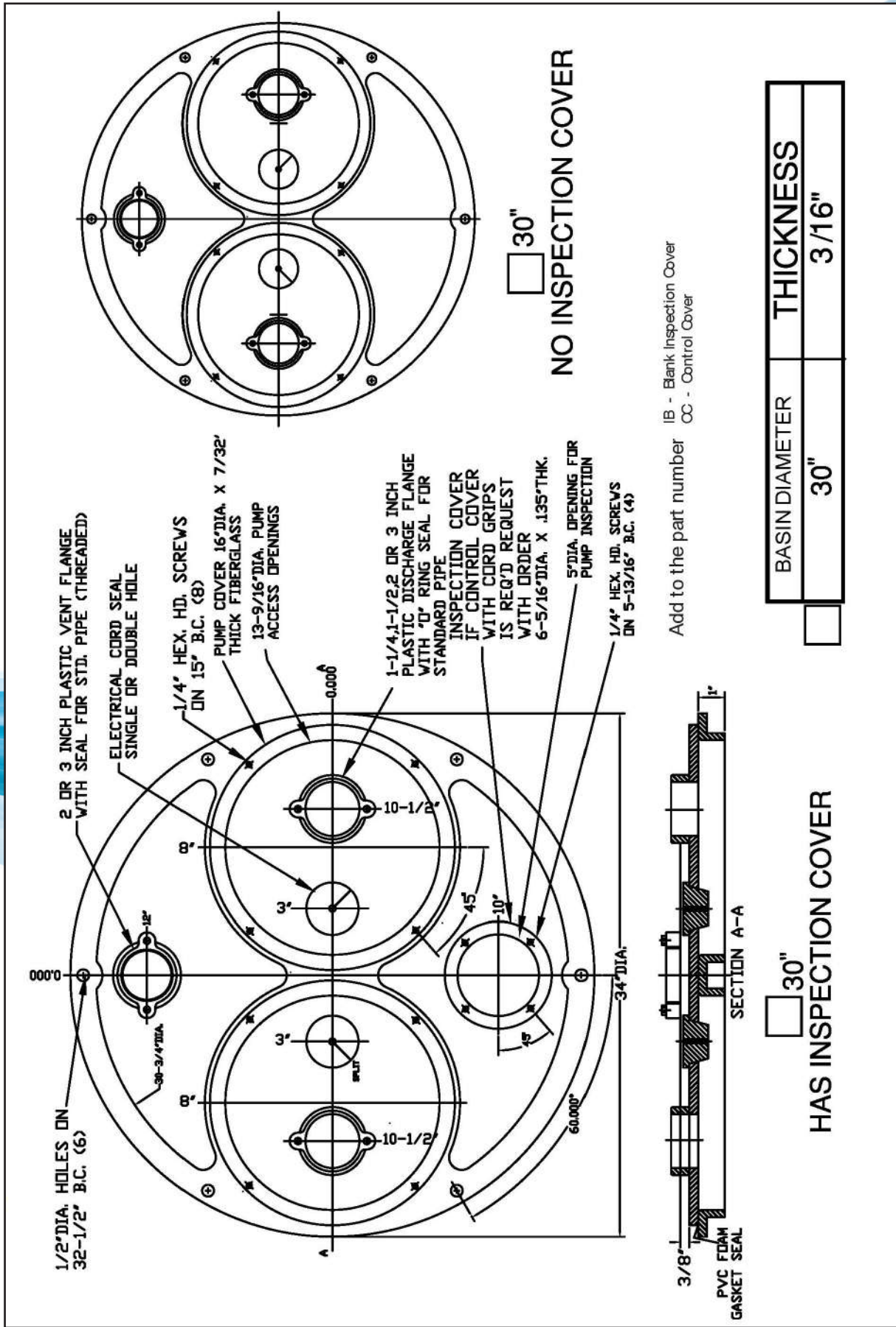





DUPLEX METAL COVER

Duplex Metal Covers

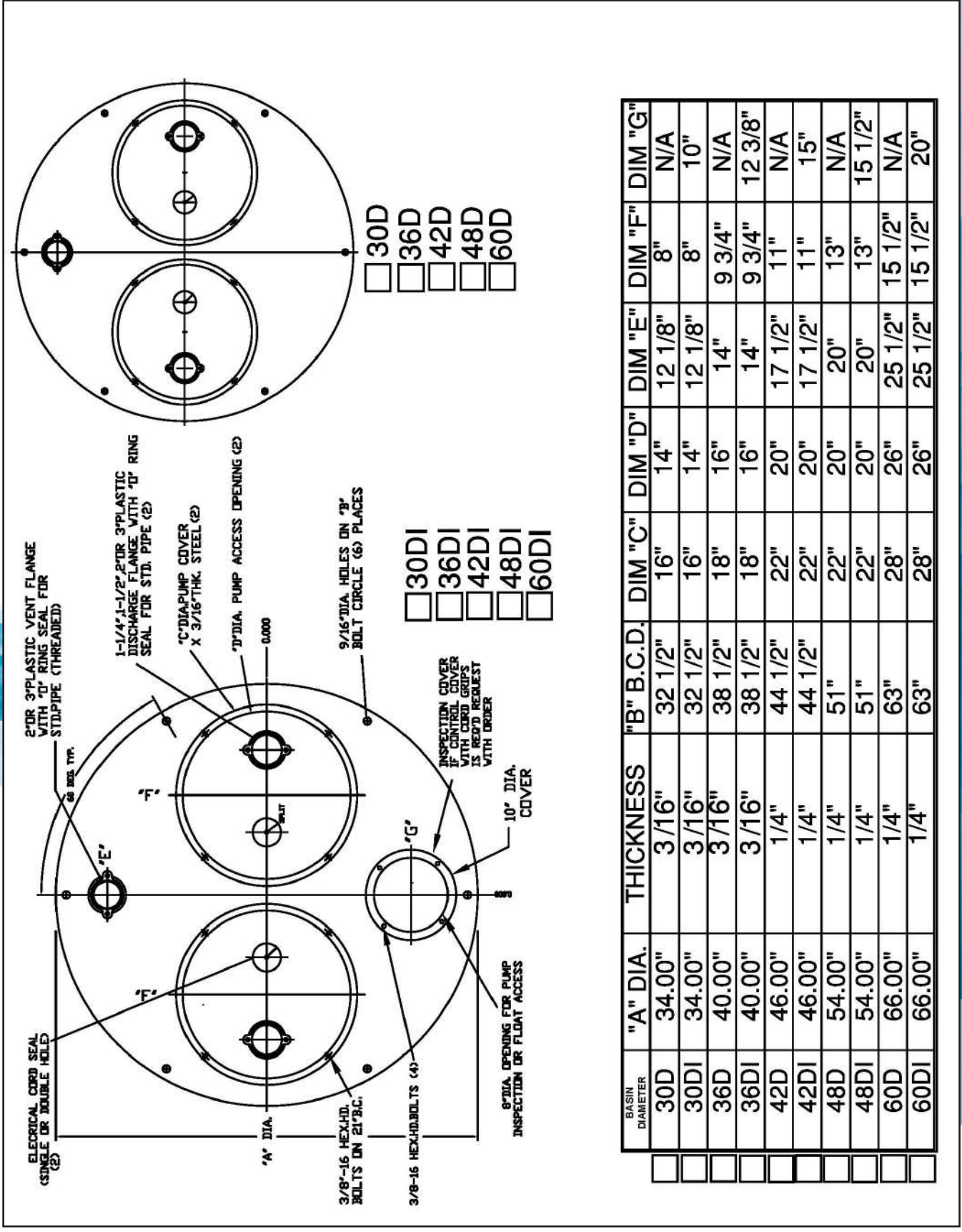

BASIN DIAMETER	"A" DIA.	THICKNESS	"B" B.C.D.	DIM "C"	DIM "D"	DIM "E"	DIM "F"	DIM "G"
30D	34.00"	3/16"	32 1/2"	16"	14"	12 1/8"	8"	N/A
30DI	34.00"	3/16"	32 1/2"	16"	14"	12 1/8"	8"	10"
36D	40.00"	3/16"	38 1/2"	18"	16"	14"	9 3/4"	N/A
36DI	40.00"	3/16"	38 1/2"	18"	16"	14"	9 3/4"	12 3/8"
42D	46.00"	1/4"	44 1/2"	22"	20"	17 1/2"	11"	N/A
42DI	46.00"	1/4"	44 1/2"	22"	20"	17 1/2"	11"	15"
48D	54.00"	1/4"	51"	22"	20"	20"	13"	N/A
48DI	54.00"	1/4"	51"	22"	20"	20"	13"	15 1/2"
60D	66.00"	1/4"	63"	28"	26"	25 1/2"	15 1/2"	N/A
60DI	66.00"	1/4"	63"	28"	26"	25 1/2"	15 1/2"	20"



# SIMPLEX SUBMERSIBLE

**PUMP INFORMATION**

- Type:  Sump Pump  
 Grinder Pump  
 Non-Clog Pump

Model NO: \_\_\_\_\_  
 Rating: \_\_\_\_\_ GPM \_\_\_\_\_ TDH  
 Motor: \_\_\_\_\_ HP \_\_\_\_\_ RPM  
 Elec: \_\_\_\_\_ PH \_\_\_\_\_ HZ \_\_\_\_\_  
 Elec: \_\_\_\_\_ FL AMPS

**DISCHARGE PIPE**

- 304 Stainless Steel  
 Sch40 Galvanized Steel  
 Sch80 PVC Pipe  
 1 1/4"  
 1 1/2"  
 2"  
 3"

**ANTI-FLOATATION FLANGE**

- Fiberglass Encapsulated  
 ASTM A-36 Steel  
 Round Fiberglass  
 None

Inspection Plate With  
 (3) 1/2" Cord Grips  
 And 1" Coupling

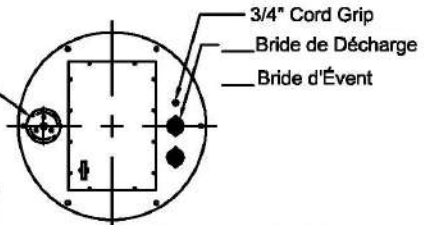

**GAS TIGHT HATCH COVER**

- Fiberglass  Aluminium  Steel

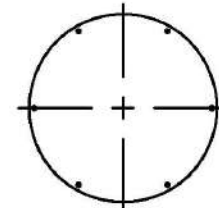

**SOLID COVER**

- Fiberglass  
 Steel

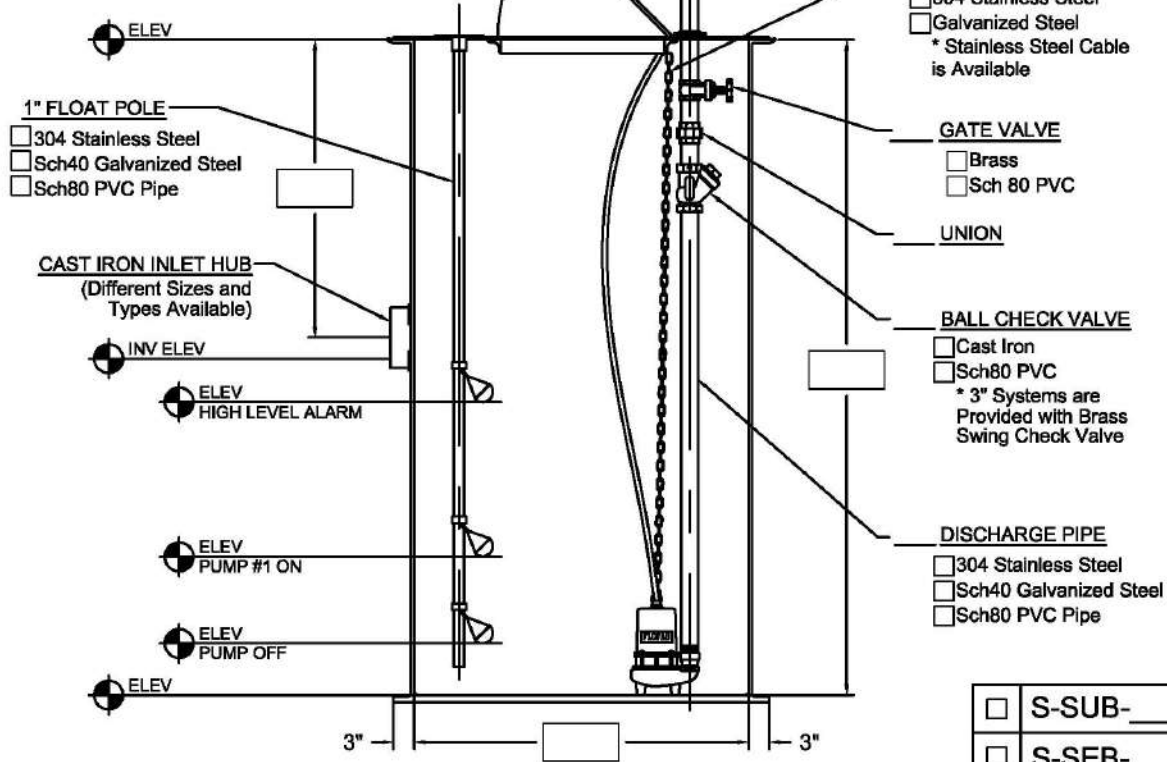

- 1" FLOAT POLE**  
 304 Stainless Steel  
 Sch40 Galvanized Steel  
 Sch80 PVC Pipe

**CAST IRON INLET HUB**  
 (Different Sizes and  
 Types Available)

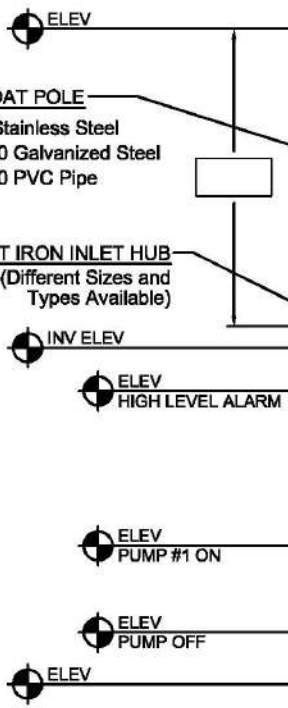

**3/16" LIFTING CHAIN**

- 304 Stainless Steel  
 Galvanized Steel  
 \* Stainless Steel Cable  
 is Available

**GATE VALVE**

- Brass  
 Sch 80 PVC

**UNION**

**BALL CHECK VALVE**

- Cast Iron  
 Sch80 PVC  
 \* 3" Systems are  
 Provided with Brass  
 Swing Check Valve

**DISCHARGE PIPE**

- 304 Stainless Steel  
 Sch40 Galvanized Steel  
 Sch80 PVC Pipe

S-SUB-\_\_\_\_\_  
 S-SEB-\_\_\_\_\_

<p>TITLE / TITRE</p> <p align="center"><b>FLO FAB</b> SIMPLEX SUBMERSIBLE</p>			
<p>PROJECT/PROJET</p>		<p>CUSTOMER / CLIENT</p>	
<p>PART LIST N° / LISTE DE MATERIEL N°</p>		<p>DATE / DATE</p> <p align="right">AUGUST 2007</p>	
<p>DRAWN BY / DESINATEUR</p> <p>M. LYMBURNER</p>	<p>SCALE / ÉCHELLE</p> <p>N/A</p>	<p>DRAWING N° / N° DESIGN</p> <p>S-SUB-16737-FN</p>	<p>REV</p> <p>0</p>



# SIMPLEX SUBMERSIBLE

**PUMP INFORMATION**

- Type:  Sump Pump  
 Grinder Pump  
 Non-Clog Pump

Model NO: \_\_\_\_\_  
 Rating: \_\_\_\_\_ GPM \_\_\_\_\_ TDH  
 Motor: \_\_\_\_\_ HP \_\_\_\_\_ RPM  
 Elec: \_\_\_\_\_ PH \_\_\_\_\_ HZ \_\_\_\_\_ v  
 Elec: \_\_\_\_\_ FL AMPS

**DISCHARGE PIPE**

- 304 Stainless Steel  
 Sch40 Galvanized Steel  
 Sch80 PVC Pipe  
 1 1/4"  
 1 1/2"  
 2"  
 3"  
 4"

**ANTI-FLOATATION FLANGE**

- Fiberglass Encapsulated  
 ASTM A-36 Steel  
 Round Fiberglass  
 None

Inspection Plate With  
 (3) 1/2" Cord Grips  
 And 1" Coupling

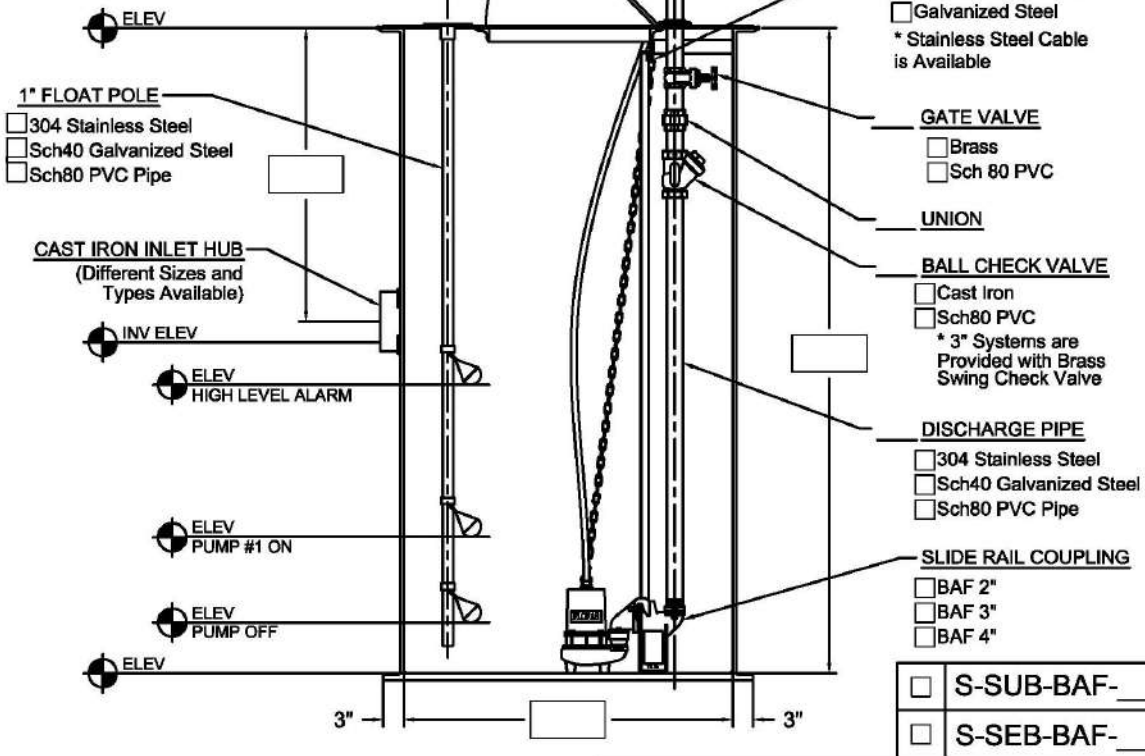
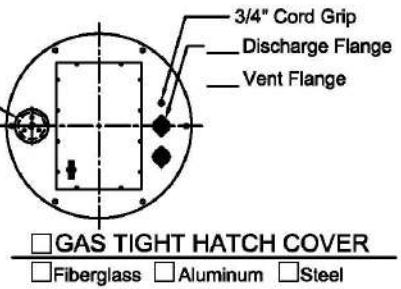

<b>FLO FAB</b>			
<b>SIMPLEX SUBMERSIBLE WITH SLIDE RAIL COUPLING</b>			
 MONTREAL (QC), CANADA TORONTO (ON), CANADA LAKE WORTH (FL), USA WWW.FLOFAB.COM		PROJECT/PROJET	
		CUSTOMER / CLIENT	
PART LIST N° / LISTE DE MATERIEL N°	DATE / DATE	<b>AUGUST 2007</b>	
DRAWN BY / DESSINATEUR	SCALE / ECHELLE	DRAWING N° / N° DESSIN	REV
M. LYMBURNER	N/A	S-SUB-BAF-16739-FN	0





# SIMPLEX SUBMERSIBLE

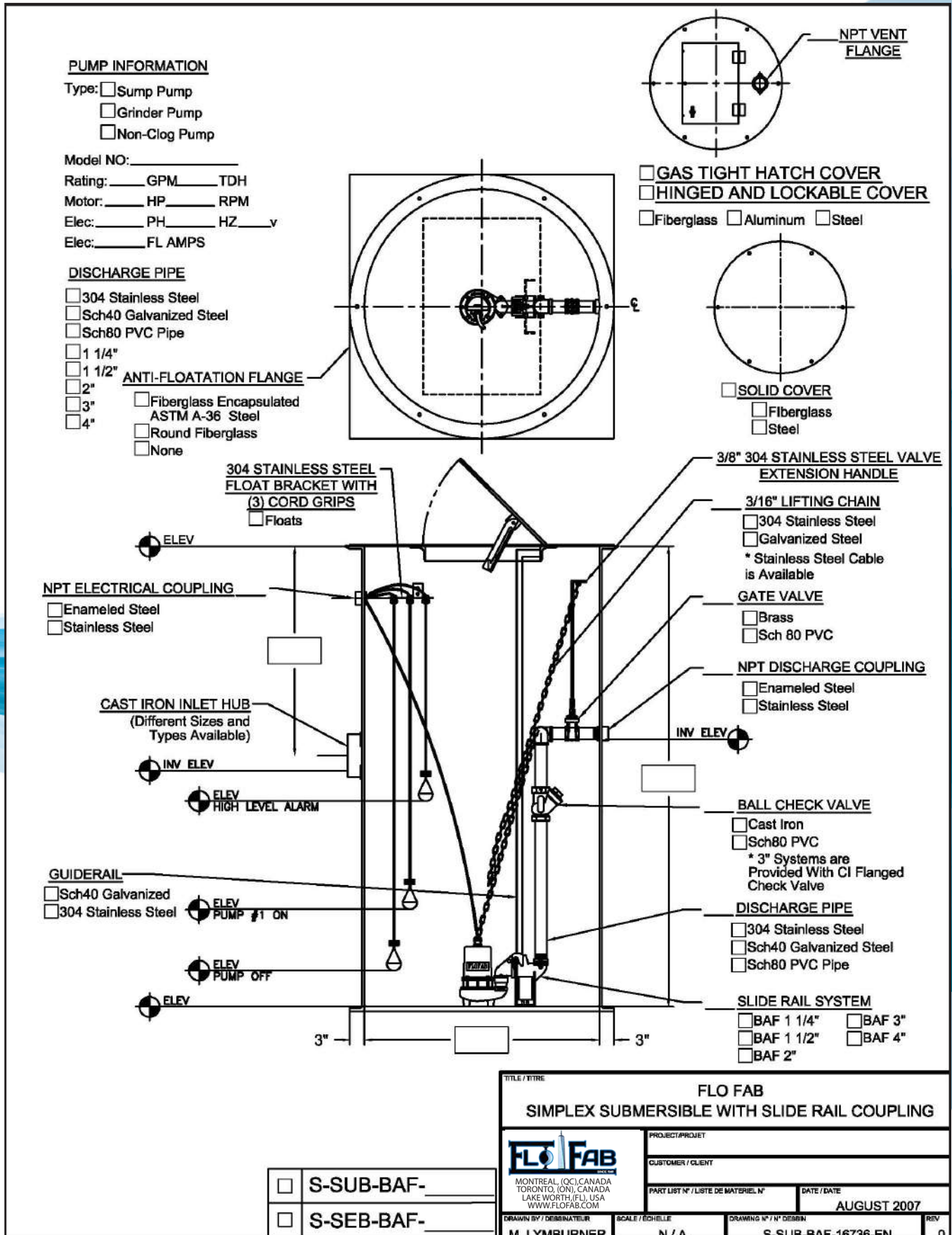



# SIMPLEX SUBMERSIBLE

**PUMP INFORMATION**

- Type:  Sump Pump  
 Grinder Pump  
 Non-Clog Pump

Model NO: \_\_\_\_\_  
 Rating: \_\_\_\_\_ GPM \_\_\_\_\_ TDH  
 Motor: \_\_\_\_\_ HP \_\_\_\_\_ RPM  
 Elec: \_\_\_\_\_ PH \_\_\_\_\_ HZ \_\_\_\_\_ V  
 Elec: \_\_\_\_\_ FL AMPS

**DISCHARGE PIPE**

- 304 Stainless Steel  
 Sch40 Galvanized Steel  
 Sch80 PVC Pipe  
 1 1/4"  
 1 1/2"  
 2"  
 3"

**ANTI-FLOATATION FLANGE**

- Fiberglass Encapsulated  
 ASTM A-36 Steel  
 Round Fiberglass  
 None

**304 STAINLESS STEEL  
 FLOAT BRACKET WITH  
 (3) CORD GRIPS**  
 Floats

**NPT ELECTRICAL COUPLING**

- Enameled Steel  
 Stainless Steel

**INLET GROMMET**  
 (Different Sizes and  
 Types Available)

**GUIDERAIL**

- Sch40 Galvanized  
 304 Stainless Steel

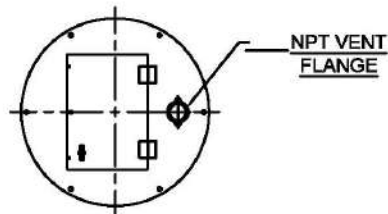

NPT VENT  
 FLANGE

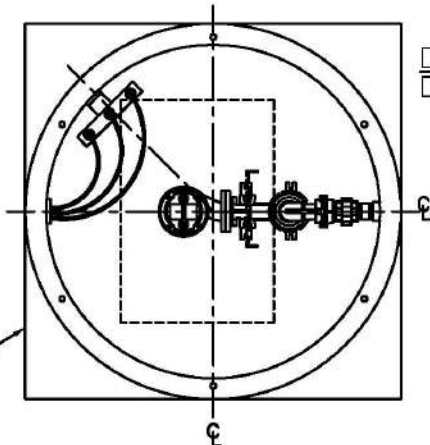

**HINGED AND LOCKABLE COVER**

- Fiberglass  Aluminum  Steel

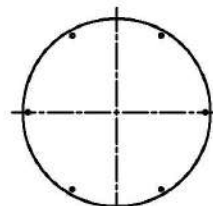

**SOLID COVER**

- Fiberglass  
 Steel

**3/8" 304 STAINLESS STEEL VALVE  
 EXTENSION HANDLE**

**3/16" LIFTING CHAIN**

- 304 Stainless Steel  
 Galvanized Steel  
 \* Stainless Steel Cable  
 is Available

**GATE VALVE**

- Brass  
 Sch 80 PVC

**UNION**

**NPT DISCHARGE COUPLING**

- Enameled Steel  
 Stainless Steel

**BALL CHECK VALVE**

- Cast Iron  
 Sch80 PVC  
 \* 3" Systems are  
 Provided with Brass  
 Swing Check Valve

**DISCHARGE PIPE**

- 304 Stainless Steel  
 Sch40 Galvanized Steel  
 Sch80 PVC Pipe

**SLIDE RAIL SYSTEM**

- BAF 3"  
 BAF 4"

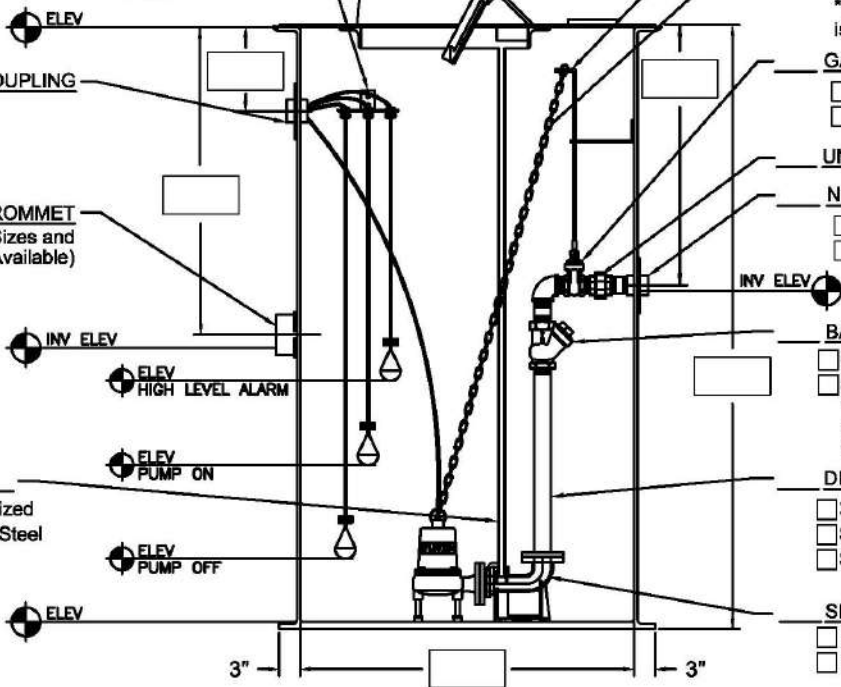

ELEV  
 INV ELEV  
 ELEV HIGH LEVEL ALARM  
 ELEV PUMP ON  
 ELEV PUMP OFF  
 ELEV

3" 3"

- S-SUB-BAF-\_\_\_\_\_  
 S-SEB-BAF-\_\_\_\_\_

TITLE / TITRE <b>FLO FAB                  SIMPLEX SUBMERSIBLE</b>			
PROJECT / PROJET _____			
CUSTOMER / CLIENT _____			
PART LIST N° / LISTE DE MATERIEL N°		DATE / DATE <b>AUGUST 2007</b>	
DRAWN BY / DESIGNED BY <b>M. LYMBURNER</b>		SCALE / ÉCHELLE <b>N/A</b>	
DRAWING N° / N° DESSIN <b>S-SUB-10144-EN</b>		REV _____	





# SIMPLEX SUBMERSIBLE

**PUMP INFORMATION**

- Type:  Sump Pump  
 Grinder Pump  
 Non-Clog Pump

Model NO: \_\_\_\_\_  
 Rating: \_\_\_\_\_ GPM \_\_\_\_\_ TDH  
 Motor: \_\_\_\_\_ HP \_\_\_\_\_ RPM  
 Elec: \_\_\_\_\_ PH \_\_\_\_\_ HZ \_\_\_\_\_ v  
 Elec: \_\_\_\_\_ FL AMPS

**DISCHARGE PIPE**

- 304 Stainless Steel  
 Sch40 Galvanized Steel  
 Sch80 PVC Pipe  
 3"  
 4"

**ANTI-FLOATATION FLANGE**

- Fiberglass Encapsulated  
 ASTM A-36 Steel  
 Round Fiberglass  
 None

**1" FLOAT POLE**

- 304 Stainless Steel  
 Sch40 Galvanized Steel  
 Sch80 PVC Pipe

**CAST IRON INLET HUB**  
 (Different Sizes and Types Available)

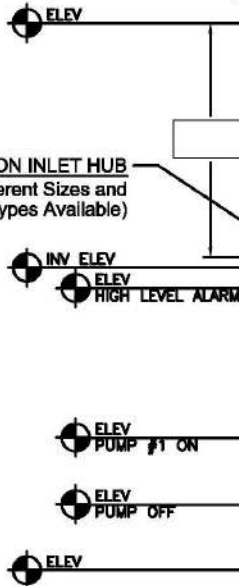

Inspection Plate With  
 (4) 1/2" Cord Grips  
 And 1" Coupling

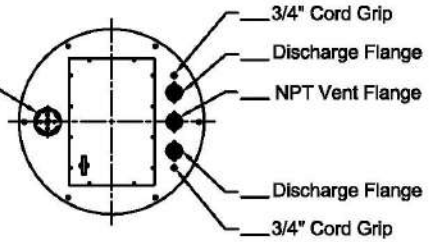
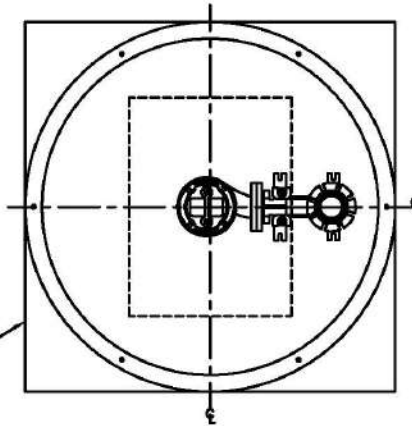

**GAS TIGHT HATCH COVER**

- Fiberglass  Aluminum  Steel

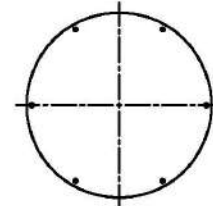

**SOLID COVER**

- Fiberglass  
 Steel

**DISCHARGE PIPE**

- 304 Stainless Steel  
 Sch40 Galvanized Steel  
 Sch80 PVC Pipe

**3/16" LIFTING CHAIN**

- 304 Stainless Steel  
 Galvanized Steel  
 \* Stainless Steel Cable is Available

**PLUG VALVE**

- \*Gate Valves Also Available  
 3"  
 4"

**CAST IRON SWING CHECK VALVE**

- 3"  
 4"

**GUIDERAIL**

- Sch40 Galvanized  
 304 Stainless Steel

**SLIDE RAIL FLANGE**

- BAF 3"  
 BAF 4"

- S-SUB-BAF-\_\_\_\_\_  
 S-SEB-BAF-\_\_\_\_\_

<b>FLO FAB</b>			
<b>SIMPLEX SUBMERSIBLE WITH SLIDE RAIL COUPLING</b>			
PROJECT/PROJET		DATE/DATE	
CUSTOMER / CLIENT		AUGUST 2007	
PART LIST N° / LISTE DE MATERIEL N°		DRAWING N° / N° DESSIN	
DRAWN BY / DESSINATEUR		SCALE / ECHELLE	
M. LYMBURNER	N/A	D-SUB-BAF-16845-FN	REV 0



# DUPLEX SUBMERSIBLE

**PUMP INFORMATION**

- Type:  Sump Pump(s)  
 Grinder Pump(s)  
 Non-Clog Pump(s)

Model NO: \_\_\_\_\_  
 Rating: \_\_\_\_\_ GPM \_\_\_\_\_ TDH  
 Motor: \_\_\_\_\_ HP \_\_\_\_\_ RPM  
 Elec: \_\_\_\_\_ PH \_\_\_\_\_ HZ \_\_\_\_\_ v  
 Elec: \_\_\_\_\_ FL AMPS

**DISCHARGE PIPE**

- 304 Stainless Steel  
 Sch40 Galvanized Steel  
 Sch80 PVC Pipe  
 1 1/4"  
 1 1/2"  
 2"  
 3"

**ANTI-FLOATATION FLANGE**

- Fiberglass Encapsulated  
 ASTM A-36 Steel  
 Round Fiberglass  
 None

Inspection Plate With  
 (4) 1/2" Cord Grips  
 And 1" Coupling

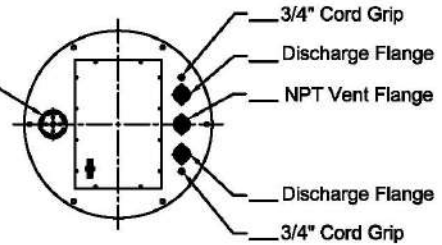

**GAS TIGHT HATCH COVER**

- Fiberglass  Aluminum  Steel

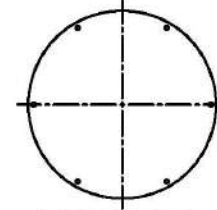

**SOLID COVER**

- Fiberglass  
 Steel

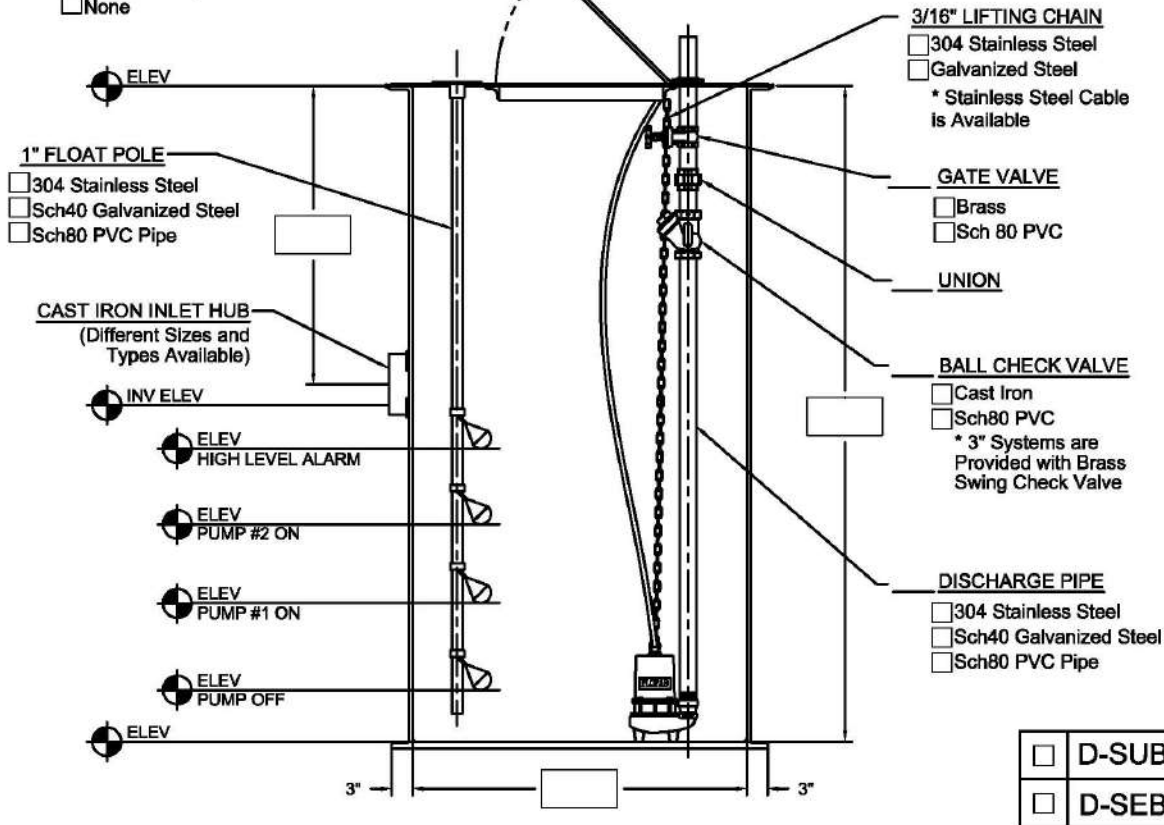

- D-SUB-\_\_\_\_\_  
 D-SEB-\_\_\_\_\_

TITLE / TITRE <b>FLO FAB</b> <b>DUPLEX SUBMERSIBLE</b>			
PROJECT / PROJET _____			
CUSTOMER / CLIENT _____			
PART LIST N° / LISTE DE MATERIEL N° _____		DATE / DATE AUGUST 2007	
DRAWN BY / DESSINATEUR M. LYMBURNER		SCALE / ÉCHELLE N/A	
DRAWING N° / N° DESSIN D-SUB-17506-EN		REV _____	



# DUPLEX SUBMERSIBLE

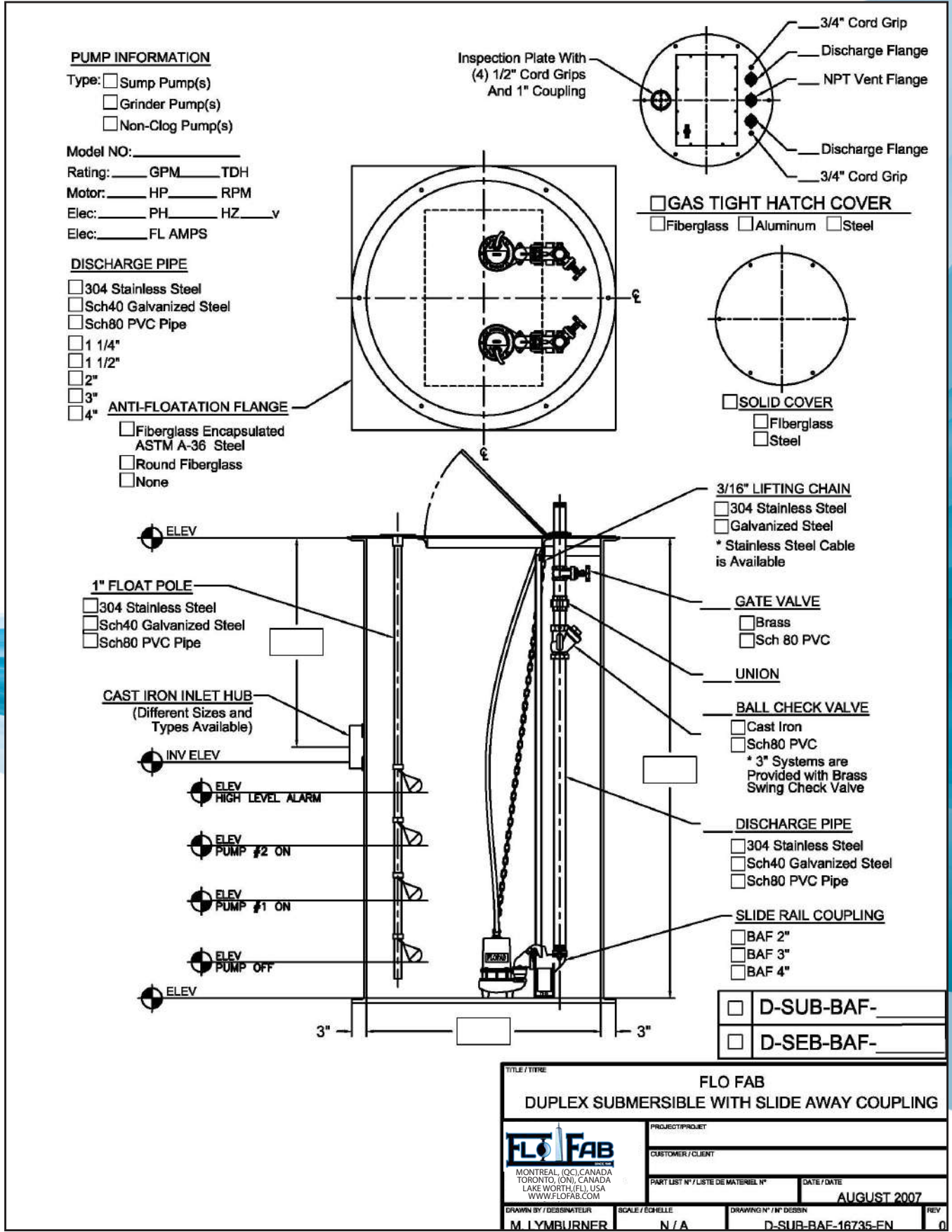





# DUPLEX SUBMERSIBLE

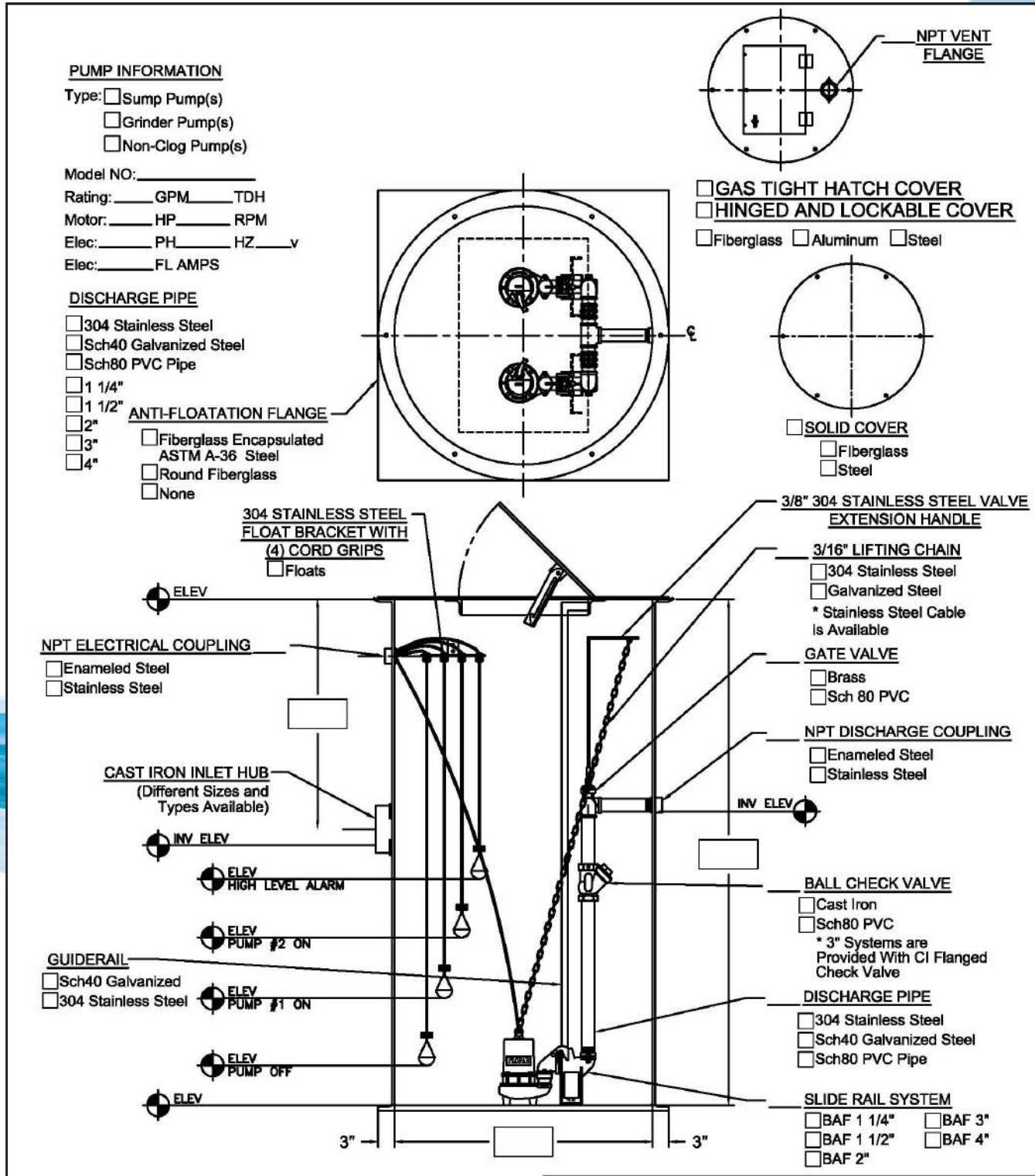

- D-SUB-BAF-\_\_\_\_\_
- D-SEB-BAF-\_\_\_\_\_

<b>FLO FAB</b>			
<b>DUPLEX SUBMERSIBLE WITH SLIDE RAIL COUPLING</b>			
MONTREAL (QC), CANADA TORONTO (ON), CANADA LAKE WORTH (FL), USA WWW.FLOFAB.COM			
PROJECT/PROJET		DATE / DATE	
CUSTOMER / CLIENT		AUGUST 2007	
PART LIST N° / LISTE DE MATERIEL N°		DRAWING N° / N° DESSIN	
M. LYMBURNER		D-SUB-BAF-16734-FN	
SCALE / ECHELLE		REV	
N / A		0	



# DUPLEX SUBMERSIBLE

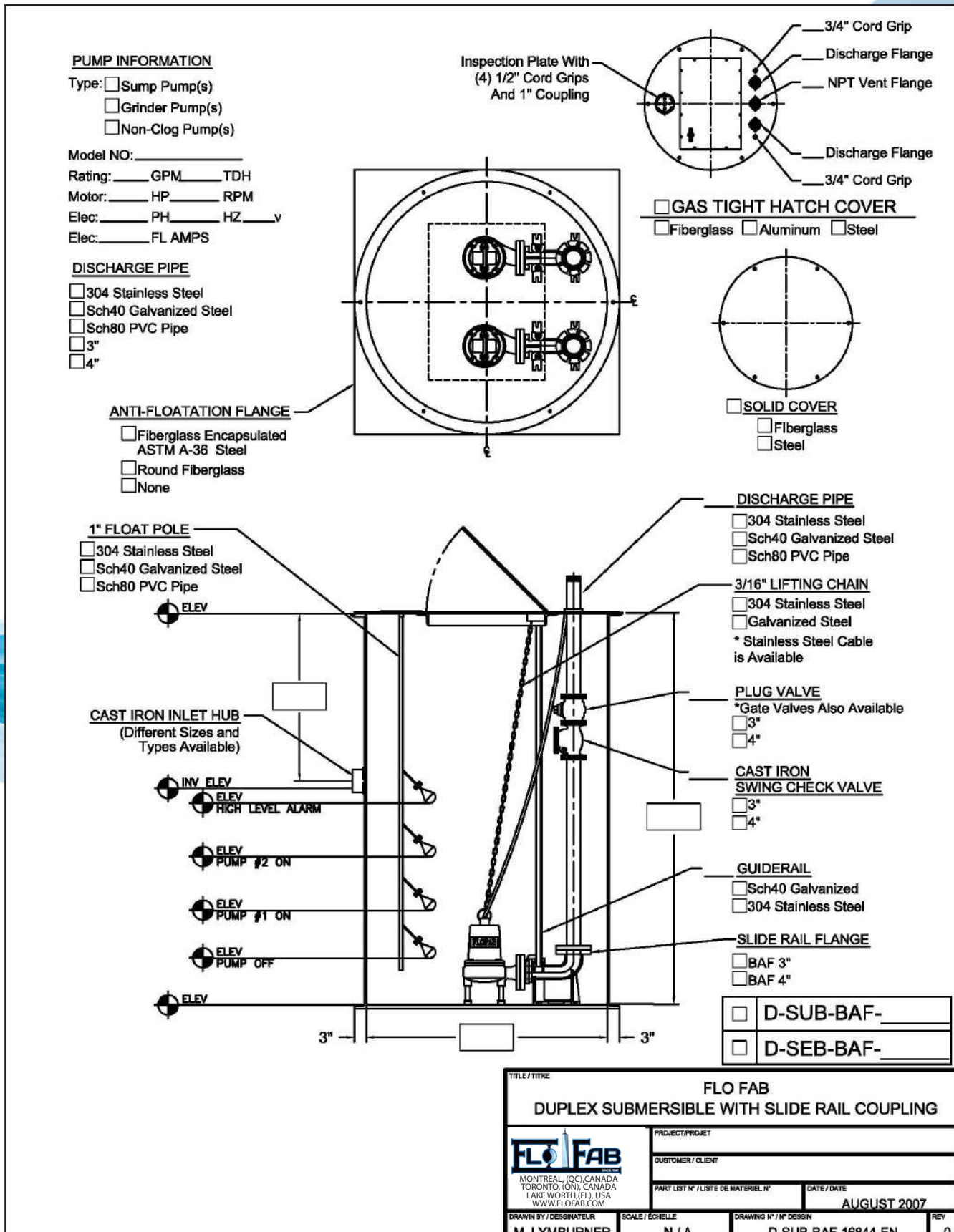



# DUPLEX SUBMERSIBLE

**PUMP INFORMATION**

- Type:  Sump Pump(s)  
 Grinder Pump(s)  
 Non-Clog Pump(s)

Model NO: \_\_\_\_\_  
 Rating: \_\_\_\_\_ GPM \_\_\_\_\_ TDH  
 Motor: \_\_\_\_\_ HP \_\_\_\_\_ RPM  
 Elec: \_\_\_\_\_ PH \_\_\_\_\_ HZ \_\_\_\_\_ V  
 Elec: \_\_\_\_\_ FL AMPS

**DISCHARGE PIPE**

- 304 Stainless Steel  
 Sch40 Galvanized Steel  
 Sch80 PVC Pipe  
 2"  
 3"  
 4"

**ANTI-FLOTATION FLANGE**

- Fiberglass Encapsulated  
 ASTM A-36 Steel  
 Round Fiberglass  
 None

**304 STAINLESS STEEL  
 FLOAT BRACKET WITH  
 (4) CORD GRIPS**  
 Floats

**NPT ELECTRICAL COUPLING**  
 Enameled Steel  
 Stainless Steel

**INLET GROMMET**  
 (Different Sizes and  
 Types Available)

**GUIDERAIL**  
 Sch40 Galvanized  
 304 Stainless Steel

**ELEV**

**ELEV**

**INV ELEV**

**ELEV  
 HIGH LEVEL ALARM**

**ELEV  
 PUMP #2 ON**

**ELEV  
 PUMP #1 ON**

**ELEV  
 PUMP OFF**

3"

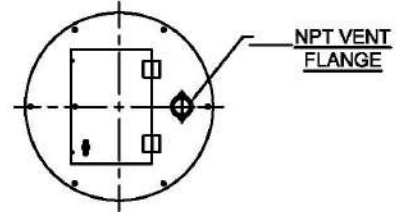

**HINGED AND LOCKABLE COVER**  
 Fiberglass  Aluminum  Steel

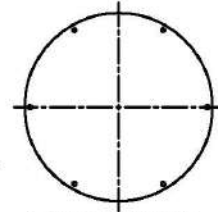

**SOLID COVER**  
 Fiberglass  
 Steel

**3/8" 304 STAINLESS STEEL VALVE  
 EXTENSION HANDLE**

**3/16" LIFTING CHAIN**  
 304 Stainless Steel  
 Galvanized Steel  
 \* Stainless Steel Cable  
 is Available

**GATE VALVE**  
 Brass  
 Sch 80 PVC

**UNION**

**NPT DISCHARGE COUPLING**  
 Enameled Steel  
 Stainless Steel

**BALL CHECK VALVE**  
 Cast Iron  
 Sch80 PVC  
 \* 3" Systems are  
 Provided with Brass  
 Swing Check Valve

**DISCHARGE PIPE**  
 304 Stainless Steel  
 Sch40 Galvanized Steel  
 Sch80 PVC Pipe

**SLIDE RAIL SYSTEM**  
 BAF 3"  
 BAF 4"

**OPTION**

- 3"  
 4"

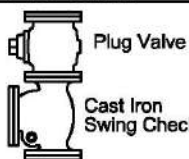

- D-SUB-BAF-** \_\_\_\_\_  
 **D-SEB-BAF-** \_\_\_\_\_

TITLE/TITRE		FLO FAB	
DUPLX SUBMERSIBLE WITH SLIDE RAIL COUPLING		PROJECT/PROJET	
CUSTOMER/CLIENT		PART LIST N° / LISTE DE MATERIEL N°	
DATE / DATE		AUGUST 2007	
DRAWN BY / DESSINATEUR	SCALE / ECHELLE	DRAWING N° / N° DESSIN	REV
M. LYMBURNER	N/A	D-SUB-10101-EN	0





## Standard for Simplex Submersible Panels

A NEMA 1 enclosure, including a main disconnect switch, one set of HRC fuses for short-circuit protection, one magnetic starter, one transformer with primary and secondary fuses (for system other than 120v), 120v control circuit, provision to connect three N.O. floats (FL1: stop float, FL2: pump start, FL3: high water level), one "Hand Off Auto" selector switch, "Power on", "Pump run", "High water level" pilot lights, audible alarm with silencer and test and dry contact for remote alarm.

NEMA Type 1  
General Purpose

To prevent accidental contact with enclosed apparatus. Suitable for application Indoors, where not exposed to unusual service conditions.

NEMA Type 2  
Driptight

To prevent accidental contact with enclosed apparatus. Excludes falling moisture or dirt.

NEMA Type 4  
Watertight

Designed to exclude water applied in form of hose stream. To protect against steam of water during cleaning operations, etc.

NEMA Type 4X  
Corrosion  
Resistant

Designed to exclude water supplied in form of hose stream and used in areas where serious corrosion problem exists.

NEMA Type 12  
Industrial Use

Excludes dust, lint, fibers and flyings or oil or coolant seepage.



## Standard for Simplex Submersible Panels

OPT#	DESCRIPTION
1	Enclosure Eemac/Nema 2 – Indoor – Falling water & light splashing
2	Inner door for tamper proofing any enclosure
3	Enclosure Eemac/Nema 12 – Dust tight
4	Enclosure Eemac/Nema 4 – Outdoor – Protection against hose directed water
4A	Enclosure Eemac/Nema 4X – Same as Item 4 but fibreglass corrosion proof
4B	Enclosure Eemac/Nema 4X – Same as item 4 but stainless steel painted corrosion proof (brushed finish available)
5	Alarm relay for remote indication
6	Alarm block (buzzer-silence selector-pilot light)
6A	Alarm block – as above but with silence push button
7	Motor overload (over current) indication per pump (pilot light)
7A	As above but with dry contact for remote indication
8	Seal leak fault per pump (conductivity relay with pilot light)
8A	As above but with dry contact for remote indication
9	Motor overheat fault indication per pump (pilot light)
9A	As above but with dry contact for remote indication
10	Pilot light for various function
11	Alarm bell
12	Elapsed time meter (Nema 1) per pump
13	Intrinsic safe relay (use when floats or electrodes are located in explosive medium)
14	Pump control using conductivity relay and electrodes
15	Loss of phase fault indication (pilot light) on incoming power (use with 3 phase supply)
17	Globe alarm (25 watt-non flashing-shatter proof)
18	Pump protection with breaker on single phase system - Max. 40 Amps - (branch circuit protection device rated – Type E rating)
19	Heater element + thermostat
22	Installation of capacitor pack in panel (for starting single phase pump)
24	Fault indication (Relay + pilot light)
31	Stop/Start with one float
32	Stop/Start with two floats
35	120V Supply for external load (Specify load)
36	Emergency stop push button
38	Low level indication (pilot light)
38A	Low level indication – shutdown with remote indication
39	Low low level indication (pilot light)
39A	Low low level indication – shut down with remote indication
40	Additional stop-start push button per pump
41	Provision for connection of solenoid
43	Remote start/stop signal
43A	24 Volt start signal
44	Lamp test push button
44A	Push to test push button
46	On delay timer (use to avoid nuisance tripping on certain faults)
47	Off delay timer



## SUBMERSIBLES



# Standard for Simplex Submersible Panels

OPT#	DESCRIPTION
48	Two positions selector
55	Indication only of pump failure to start
60	Float failure alarm
63	Ammeter – CT operated – for one pump
64	Voltmeter for system voltage – Direct read
65	Pump stop indication
67	Fault with latching relay and reset button
68	Remote signal for low of power
69	Current detection relay per pump (to confirm pump running)
70	Loss of phase and phase reversal detection and indication (three phase system)
72	Timer for minimum run
73	Timer for maximum run
74	General alarm indication with relay
77	Lightning arrestor
78	Extra for flashing function on pilot light or globe
79	Ground fault indication with pilot light (no stopping of pump)
80	Duplex receptacle – 120 V – 100Watts
81	Motor circuit interrupter (instead of fuses) – Max. 40 Amps – Rated as branch circuit protection device – Type E
81A	Moulded case circuit protector (replaces fuses)
82	Repeat cycle timer
84	Telephone dialler with battery back-up
85	Push button for misc. sequence (describe sequence)
86	Alarm high level
87	Pump start counter
88	Variable freq. drive for variable speed pumps
89	Line or load reactor for above
91	Stop pump on low level in manual mode
93	Horn
95	Auto reset of latched faults on resumption of power
99	Blown fuse indication for single phase system
101A	Circuit breaker protection for primary and secondary of transformer
101B	Circuit breaker protection for secondary of transformer
103	Soft start for reduced voltage starting
105	Forced ventilation (Louvre-Fan-Thermostat)
106	Reversing starter
108	Through the door overload reset buttons
109	Tank alert
112	U/L approval of panel
113	Provision for padlock on enclosure





# SIMPLEX SUBMERSIBLES

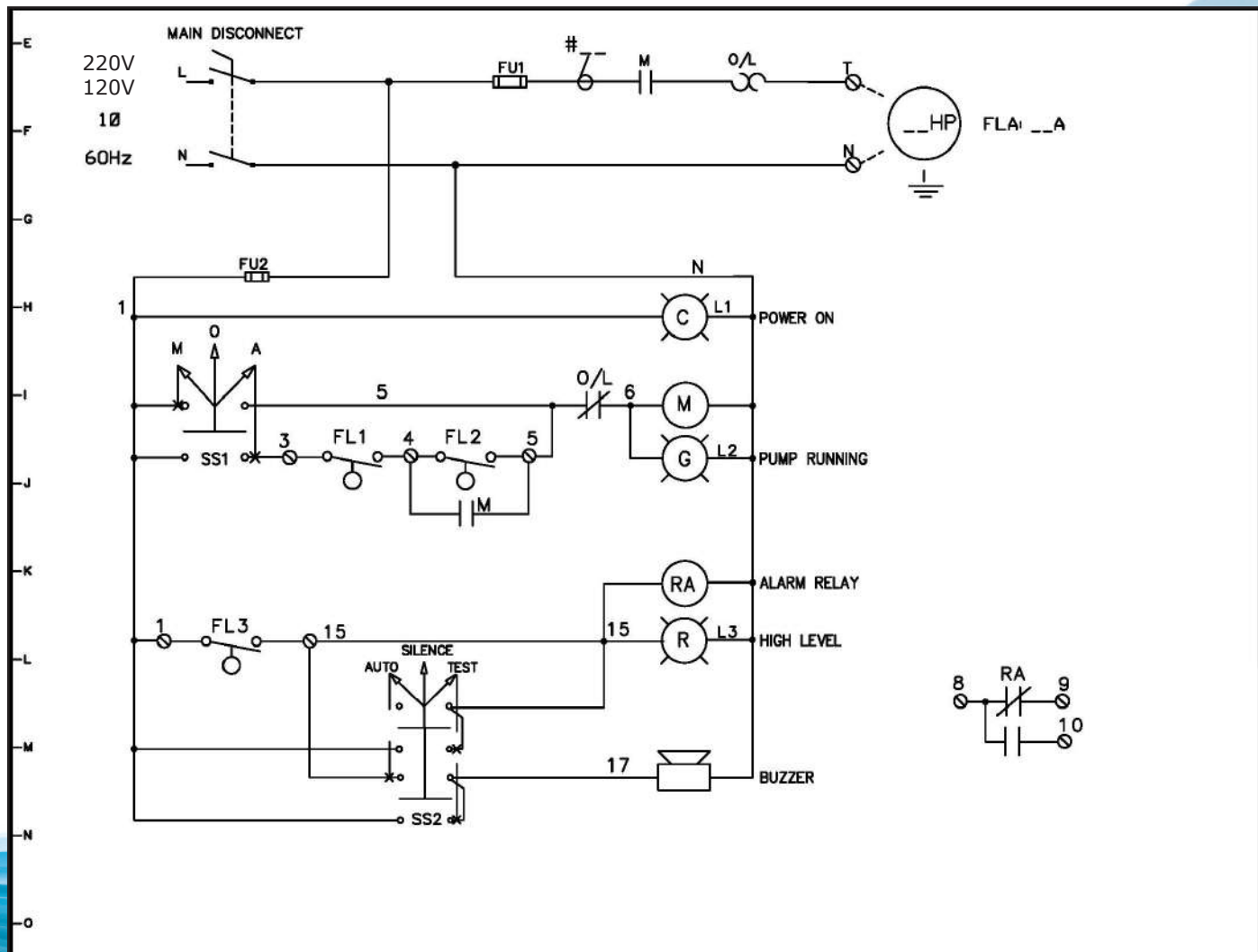

NEMA 1 ENCLOSURE

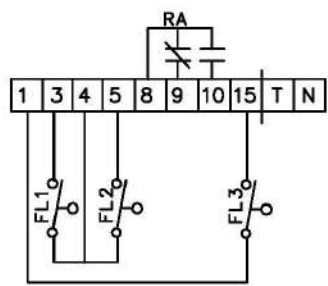
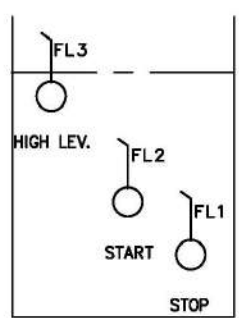
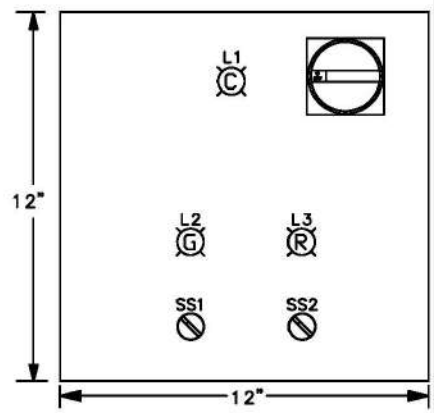

REMARKS: REMARQUES :										REV.		DESCRIPTION		
					TITLE: SIMPLEX					DRAWING #:		DPT.:		
DRAWN BY: S. DeMONTIGNY		CONTROLLED BY:		DATE: 12-05-2000		PROJECT:					S. D. 8506-A		00	
										PAGE 1 OF 1				

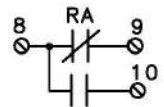
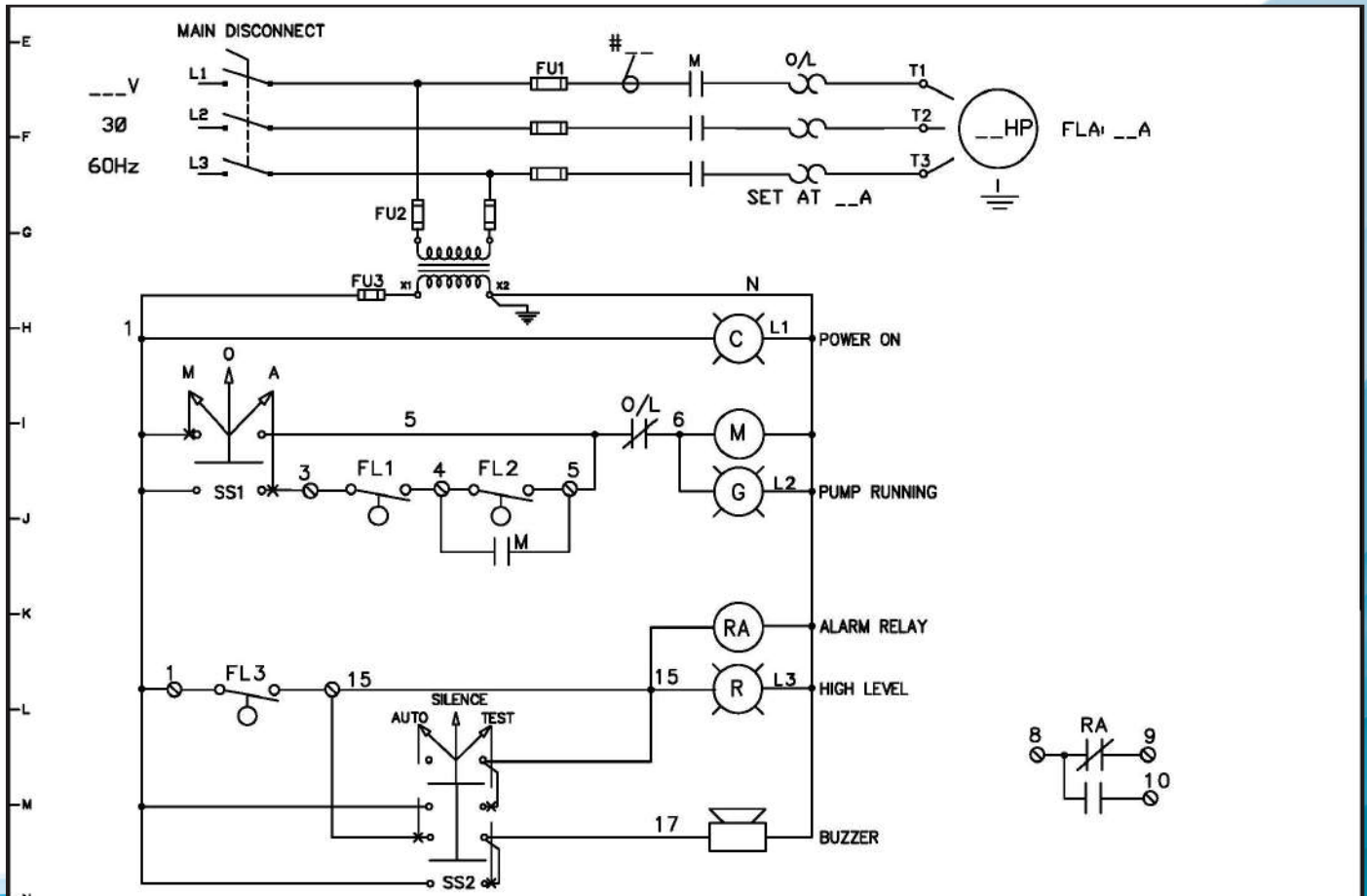

NEMA 1 ENCLOSURE

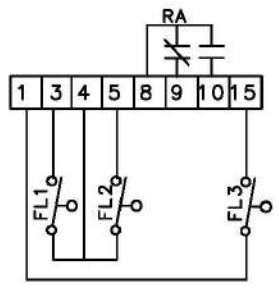
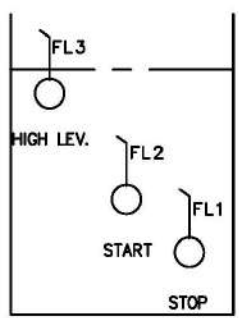
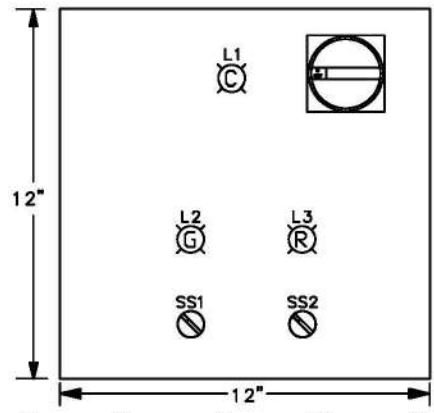

REMARKS: REMARQUES :										REV.		DESCRIPTION	
										TITLE: SIMPLEX		DRAWING #: S. D. 8532-A	
PROJECT:										DPT.:		00	
DRAWN BY: S. DeMONTIGNY		CONTROLLED BY:		DATE: 12-05-2000						PAGE 1 OF 1			



## Standard for Duplex Submersible Panels

A NEMA 1 enclosure, including a main disconnect switch, two sets of HRC fuses for short-circuit protection, two magnetic starters, one transformer with primary and secondary fuses (for system other than 120v), 120v control circuit, alternating circuit, provision to connect four N.O. floats (FL1: stop float, FL2: lead pump start, FL3: lag pump start, FL4: high water level), automatic transfer to lag pump in case of lead pump overload, two "Hand Off Auto" selectors switches, "Power on", "Pump 1 run", "Pump 2 run", "High water level", pilot lights, audible alarm with silencer and test and dry contact for remote alarm.

NEMA Type 1  
General Purpose

To prevent accidental contact with enclosed apparatus. Suitable for application Indoors, where not exposed to unusual service conditions.

NEMA Type 2  
Driptight

To prevent accidental contact with enclosed apparatus. Excludes falling moisture or dirt.

NEMA Type 4  
Watertight

Designed to exclude water applied in form of hose stream. To protect against steam of water during cleaning operations, etc.

NEMA Type 4X  
Corrosion  
Resistant

Designed to exclude water supplied in form of hose stream and used in areas where serious corrosion problem exists.

NEMA Type 12  
Industrial Use

Excludes dust, lint, fibers and flyings or oil or coolant seepage.



## SUBMERSIBLES



# Standard for Duplex Submersible Panels

OPT#	DESCRIPTION
3	Enclosure Eemac/Nema 12 – Dust tight
4	Enclosure Eemac/Nema 4 – Outdoor – Protection against hose directed water
4A	Enclosure Eemac/Nema 4X – Same as Item 4 but fibreglass corrosion proof
4B	Enclosure Eemac/Nema 4X – Same as item 4 but stainless steel painted corrosion proof (brushed finish available)
5	Alarm relay for remote indication
6	Alarm block (buzzer-silence selector-pilot light)
6A	Alarm block – as above but with silence push button
7	Motor overload (over current) indication per pump (pilot light)
7A	As above but with dry contact for remote indication
8	Seal leak fault per pump (conductivity relay with pilot light)
8A	As above but with dry contact for remote indication
9	Motor overheat fault indication per pump (pilot light)
9A	As above but with dry contact for remote indication
10	Pilot light for various function
11	Alarm bell
12	Elapsed time meter (Nema 1) per pump
13	Intrinsic safe relay (use when floats or electrodes are located in explosive medium)
14	Pump control using conductivity relay and electrodes
15	Loss of phase fault indication (pilot light) on incoming power (use with 3 phase supply)
17	Globe alarm (25 watt-non flashing-shatter proof)
18	Pump protection with breaker on single phase system - Max. 40 Amps - (branch circuit protection device rated – Type E rating)
19	Heater element + thermostat
20	Time clock (use for alternating pumps – Specify 12 hours/24 hours/weekly)
21	Main disconnect
21A	Disconnect for each pump controlled by panel
22	Installation of capacitor pack in panel (for starting single phase pumps)
23	Alternating relay (Electro-Mech)
24	Fault indication (Relay + pilot light)
25	Alternating relay - Electronic
26	Alternator - Mechanical
27	Programmable controller
31	Stop/Start with one float
32	Stop/Start with two floats
35	120V Supply for external load (Specify load)
36	Emergency stop push button
38	Low level indication (pilot light)
38A	Low level indication – shutdown with remote indication
39	Low low level indication (pilot light)
39A	Low low level indication – shut down with remote indication
40	Additional stop-start push button per pump
41	Provision for connection of solenoid
43	Remote start/stop signal
43A	24 Volt start signal
44	Lamp test push button
44A	Push to test push button



## Standard for Duplex Submersible Panels

OPT#	DESCRIPTION
47	Off delay timer
48	Two positions selector
55	Indication only of pump failure to start
60	Float failure alarm
62	Lead pump selector switch
63	Ammeter – CT operated – for two pumps
64	Voltmeter for system voltage – Direct read
65	Pump stop indication
67	Fault with latching relay and reset button
68	Remote signal for low of power
69	Current detection relay per pump (to confirm pump running)
70	Loss of phase and phase reversal detection and indication (three phase system)
72	Timer for minimum run
73	Timer for maximum run
74	General alarm indication with relay
75	Lag pump demand indication (pilot light)
77	Lightning arrester
78	Extra for flashing function on pilot light or globe
79	Ground fault indication with pilot light (no stopping of pump)
80	Duplex receptacle – 120 V – 100Watts
81	Motor circuit interruptor (instead of fuses) – Max. 40 Amps – Rated as branch circuit protection device – Type E
81A	Moulded case circuit protector (replaces fuses)
82	Repeat cycle timer
84	Telephone dialler with battery back-up
85	Push button for misc. sequence (describe sequence)
86	Alarm high level
86A	Start lag pump on high level
87	Pump start counter
88	Variable freq. drive for variable speed pumps
89	Line or load reactor for above
91	Stop pump on low level in manual mode
93	Horn
95	Auto reset of latched faults on resumption of power
99	Blown fuse indication for single phase system
100	Incoming power from two sources with one control transformer
100A	Incoming power from two sources with two control transformers
101A	Circuit breaker protection for primary and secondary of transformer
101B	Circuit breaker protection for secondary of transformer
103	Soft start for reduced voltage starting
104	Mini-Cas II for seal and temperature fault on Flyght pumps (one per pump)
105	Forced ventilation (Louvre-Fan-Thermostat)
106	Reversing starter
108	Through the door overload reset buttons
109	Tank alert
112	U/L approval of panel
113	Provision for padlock on enclosure





# DUPLEX SUBMERSIBLE

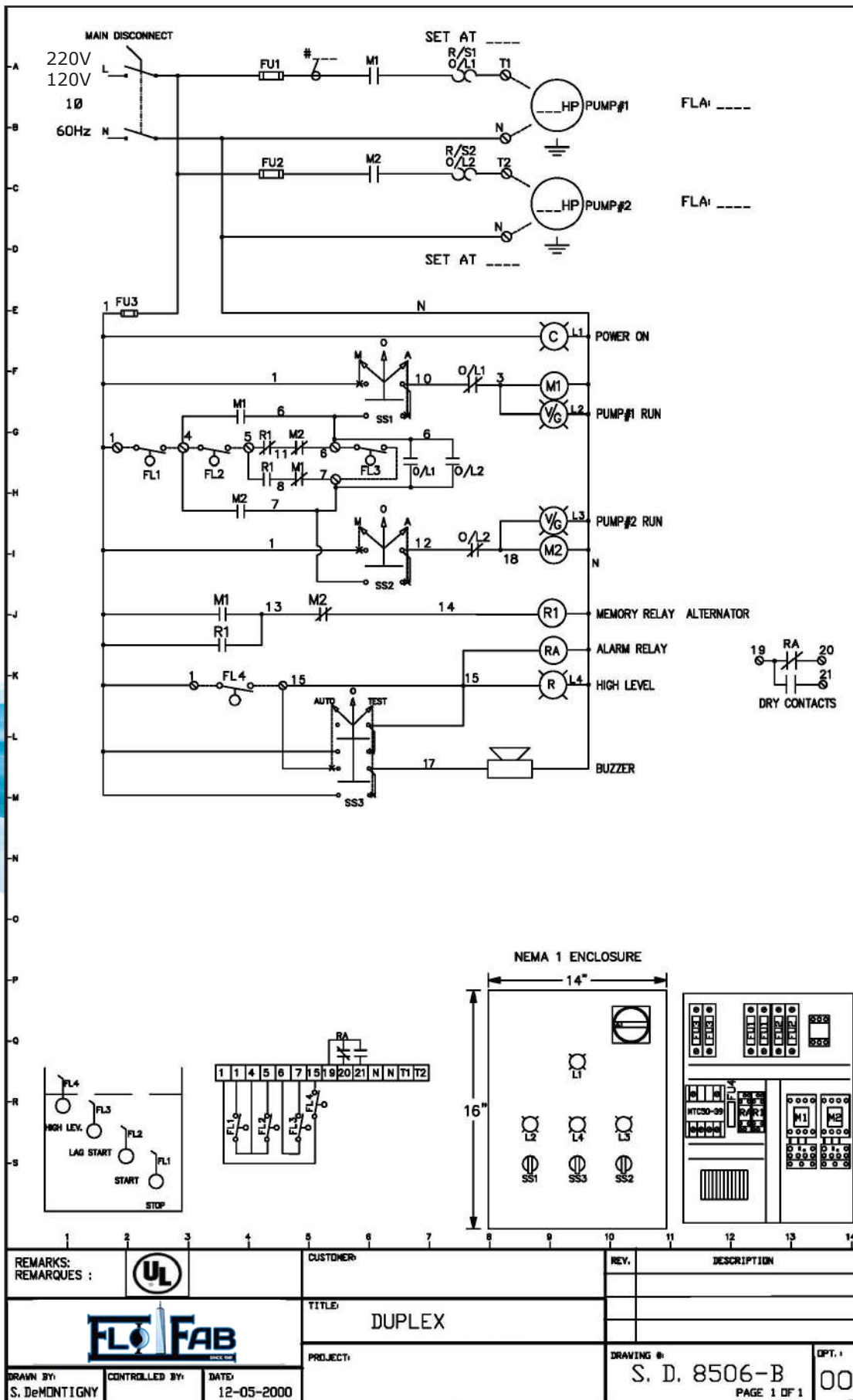

REMARKS: REMARQUES :			CUSTOMER:		REV.	DESCRIPTION
			TITLE: DUPLX			
DRAWN BY: S. DeMONTIGNY		CONTROLLED BY:	DATE: 12-05-2000	PROJECT:	DRAWING #: S. D. 8506-B	OPT. # 00
					PAGE 1 OF 1	





# DUPLEX SUBMERSIBLE

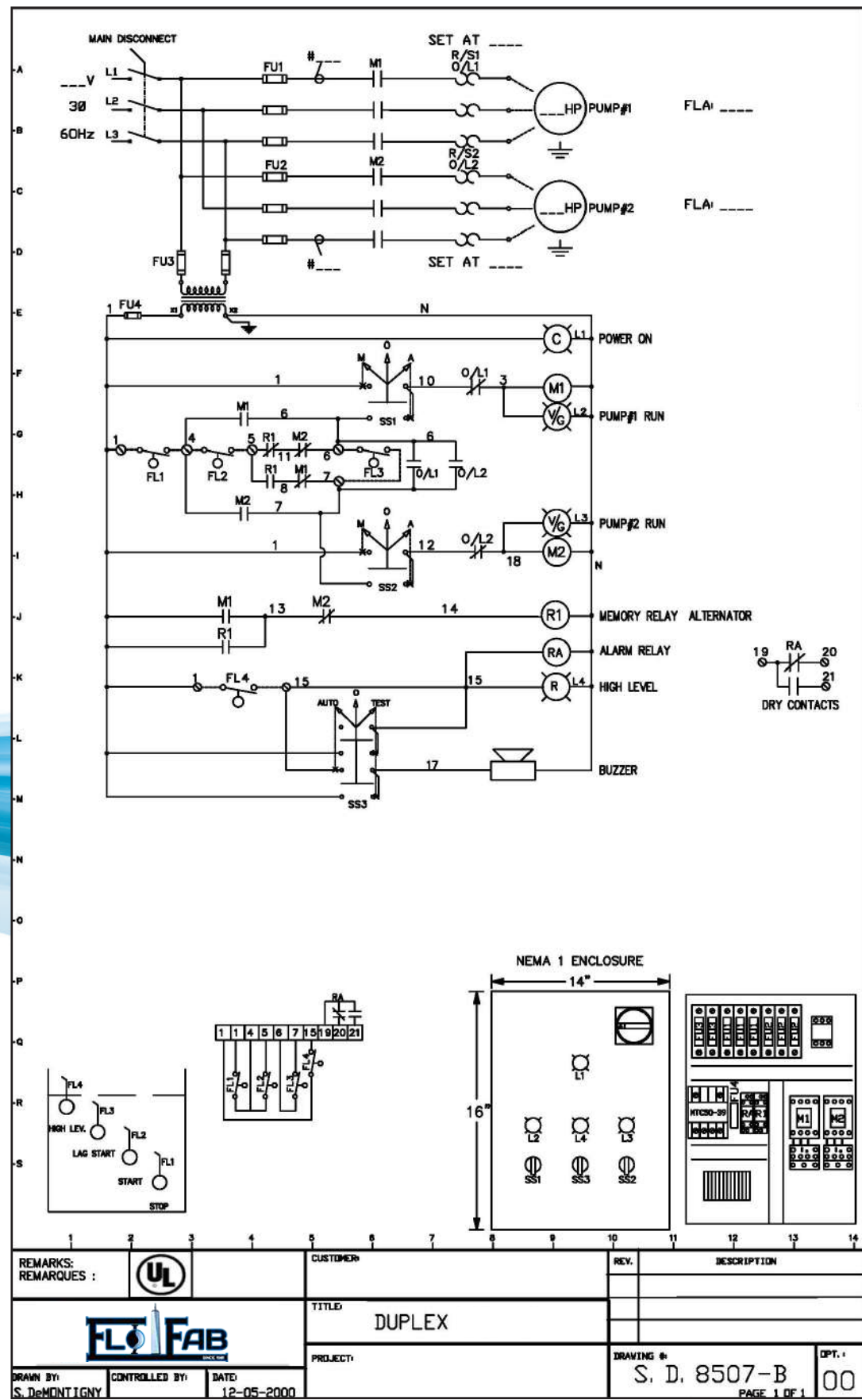



# DUPLEX SUBMERSIBLE

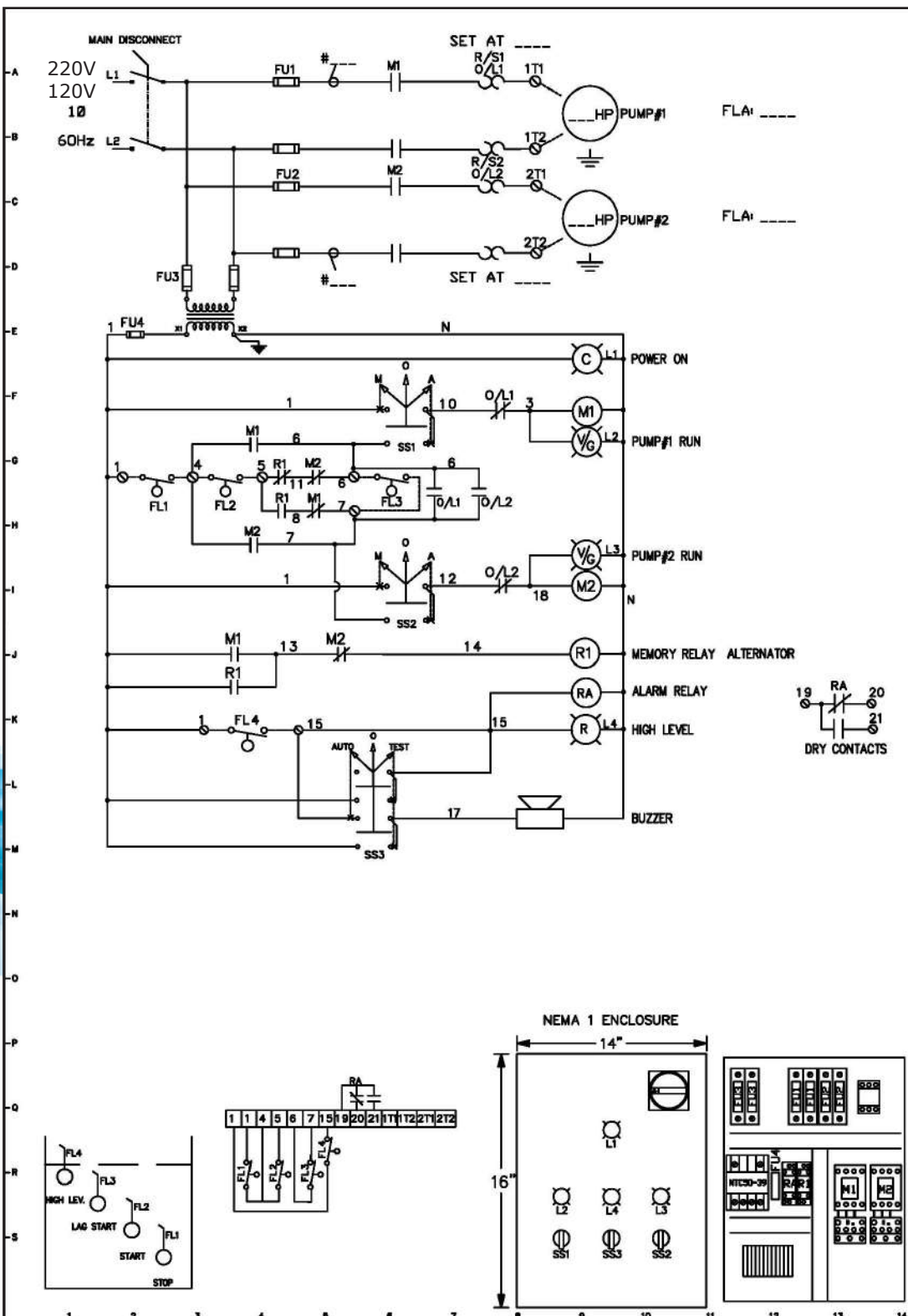

REMARKS:		CUSTOMER:	REV.	DESCRIPTION
		TITLE: DUPLEX		
PROJECT:	DRAWING #: S. D. 8511-B	OPT. 1: 00		
DRAWN BY: S. DeMONTIGNY	CONTROLLED BY:	DATE: 12-05-2000	PAGE 1 OF 1	

We are proud supplier for the following  
completed and on going projects :



**250 N 10th  
Avenue North**  
250 N 10th St, Brooklyn,  
NY, USA



**Allegria Hotel**  
80 W Broadway,  
Long Beach, NY, USA



**EvoloS Tower**  
121 de la Pointe N Road-  
Verdun, Québec, Canada



**Bogle Vineyards**  
37783 Co Rd 144,  
Clarksburg, CA,

## Sales and Service:

Quebec, Canada  
Tel. : (450) 621-2995  
Fax : (450) 621-4995

Lake Worth  
Florida, USA  
33467-5749

Toronto, Canada  
Tel. : +1 (647) 544-2995

[www.flofab.com](http://www.flofab.com)

SERVICE 24/7 : [parts@flofab.com](mailto:parts@flofab.com)

