

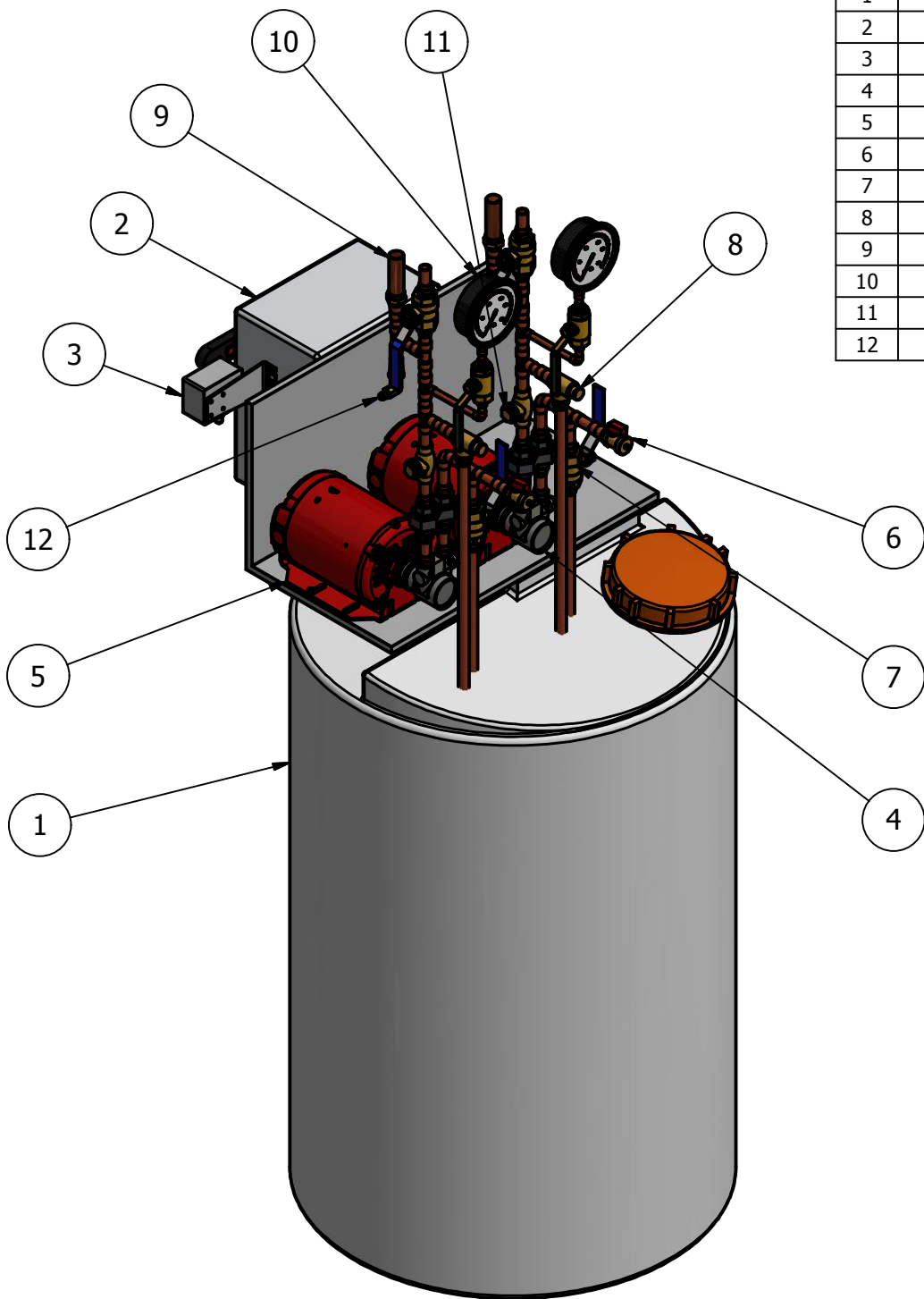

PARTS LIST		
ITEM	QTY	DESCRIPTION
1	1	106 GAL. POLYETHYLENE TANK
2	1	CONTROL PANEL
3	1	PRESSURE SWITCH
4	2	CLOSED-COUPLED ROTARY VANE
5	1	MOTOR
6	2	HOSE VALVE
7	2	BALL VALVE
8	2	PRESSURE RELIEF VALVE
9	2	WATER HAMMER ARRESTER
10	2	PRESSURE GAUGE
11	2	CHECK VALVE
12	2	AIR FITTING



THIS DRAWING MUST BE SENT WITH PURCHASE ORDER

DESIGNER G. BOLDUC	DATE 06/08/2016	TITLE / TITRE DUPLEX GLYCOL SYSTEM 100 GAL.	
		PROJECT / PROJET	
		CUSTOMER / CLIENT	
MONTREAL, (QC), CANADA TORONTO, (ON), CANADA LAKE WORTH, (FL), USA WWW.FLOFAB.COM		QUOTE	TAG
DWG NO. DUPLX GLYCOL SYSTEM 100 GAL.		REV 1	
SCALE / ECHELLE 1/10		JOB NO.	SHEET 1 OF 2

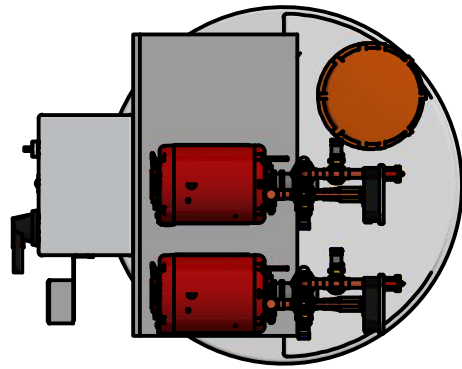

DISCHARGE

SUCTION

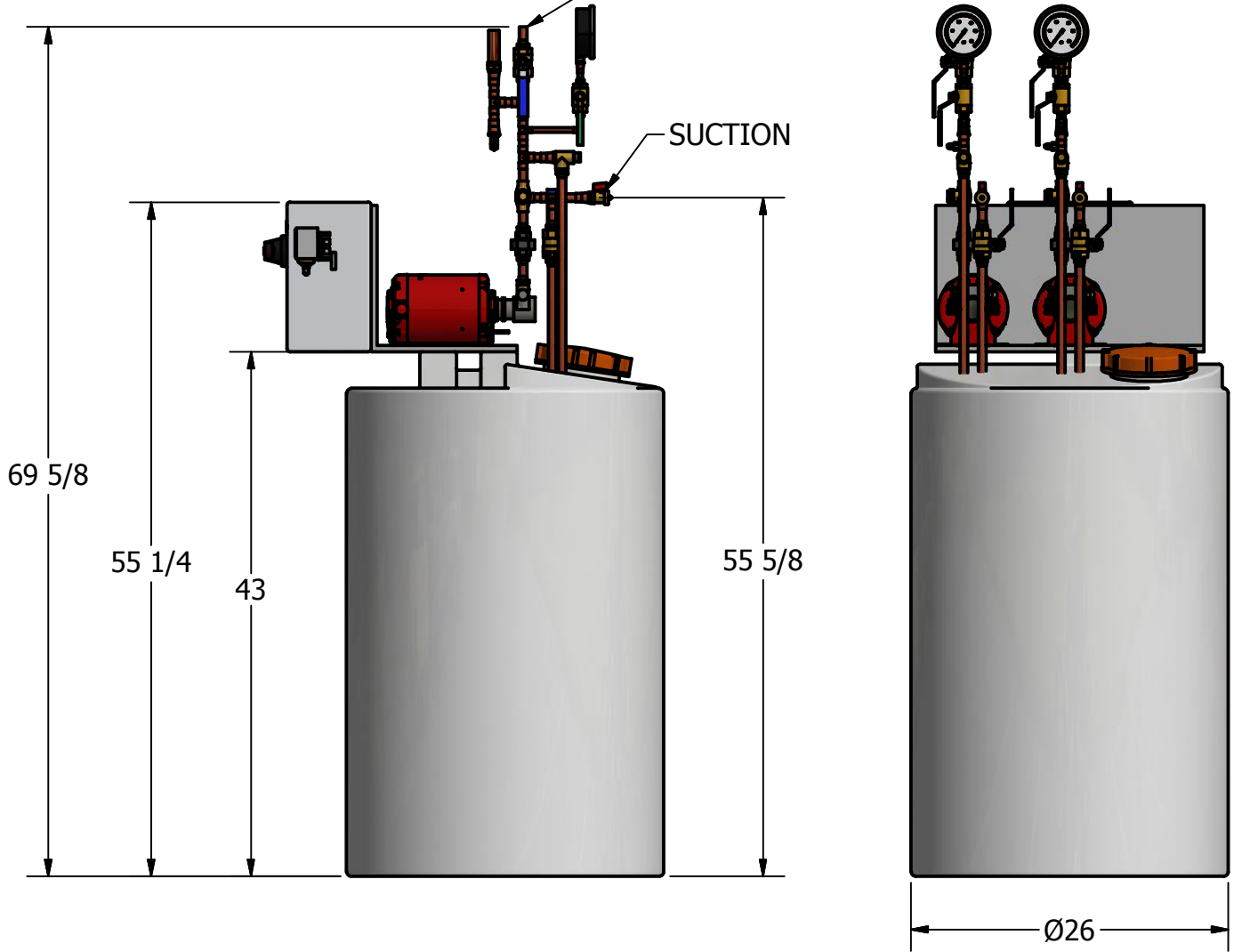

THIS DRAWING MUST BE SENT WITH PURCHASE ORDER

DESIGNER
G. BOLDUC

DATE
06/08/2016

TITLE / TITRE
DUPLIX GLYCOL SYSTEM 100 GAL.



PROJECT / PROJET

CUSTOMER / CLIENT

QUOTE

TAG

MONTREAL, (QC), CANADA
TORONTO, (ON), CANADA
LAKE WORTH, (FL), USA
WWW.FLOFAB.COM

DWG NO. DUPLIX GLYCOL SYSTEM 100 GAL.

REV
1

SCALE / ECHELLE
1/14

JOB NO.

SHEET 2 OF 2