

INSTALLATION, OPERATION and MAINTENANCE MANUAL

www.flofab.com



FLO FAB

Go

Glycol Fill System Series "GLY"

With the **FLO**



Manufacturer of Pumps, Tanks, Heat Exchangers & Accessories
for HVAC Market After-Sales Parts and Services

Glycol Fill System
Series "GLY"

FLO FAB INC
LAKE WORTH,
FLORIDA, USA

TABLE OF CONTENTS

1. PRIOR TO OPERATION	2
2. CARE UNDER OPERATION	2
3. CARE AFTER OPERATION	2
4. APPLICATION	3
5. TROUBLE SHOOTING CHART	3
6. SERVICE AND WARRANTY	4
7. TESTING	4
8. OPERATION	4
9. INSTALLATION	4
10. STARTING-UP	5
11. SYSTEM MAINTENANCE	5
12. OPERATING INSTRUCTIONS - ROTARY VANE PUMPS	6

C A U T I O N

PLEASE READ AND KEEP THESE INSTRUCTIONS. READ CAREFULLY BEFORE BEGINNING TO ASSEMBLE, INSTALL, RUN, OPERATE OR SERVICE THE DESCRIBE APPARATUS. PROTECT YOURSELF AND THE OTHERS BY FOLLOWING WELL ALL THE SAFETY INFORMATIONS. DISREGARDING THOSE INSTRUCTIONS CAN RESULT IN SOME SERIOUS BODY INJURIES AND/OR SOME MATERIAL DAMAGE, SO KEEP THOSE INSTRUCTIONS FOR FURTHER REFERENCES. ALSO, PEOPLE WHO ARE RESPONSABLE FOR INSTALLATION AND MAINTENANCE OF THE STRAINERS, ALWAYS HAVE TO BE CAREFUL FOR SOME LIQUID LEAKS AND ALWAYS HAVE TO PROTECT THEMSELVES PROPERLY. THE STRAINERS THAT ARE TAKEN OFF FOR THE SERVICE MUST BE MANIPULATED KNOWING THE PRESENCE OF LIQUID IN THE SYSTEM.

1. P R I O R T O O P E R A T I O N

- 1.1. Be sure to provide an adequate grounding and install with leakage breaker to prevent the users from serious electric shock injury.
- 1.2. Make sure the voltage of the power supply are identical to the indications of the nameplate (label) on the pump. Do not plug into other voltage and phase than indicated on the nameplate.
- 1.3. Do not have a dry-run in the air, it will damage the pump.

DO NOT USE THE PUMP IN EXPLOSIVE ENVIRONMENT, AND/OR ANY OTHER AREA WHERE THERE ARE PEOPLE; SERIOUS ACCIDENTS CAN OCCUR

2. C A R E U N D E R O P E R A T I O N

- 2.1. **When the pump stops suddenly (by the motor protection device) :**
The motor protection device is built-in and shuts off the circuit automatically to prevent the motor from burning-out when the motor is overloaded due to clogging by foreign particles or when plugged-in to wrong power source (Voltage, Frequency, etc.). Should the pump stop suddenly, please check piping, pump itself, connection of electrical cable to power source, etc. The motor protector always automatically trips-off in a few seconds if there is any abnormality. Please resume the operation after clearing the trouble and leave the pump as it is.
- 2.2. Please consult your local dealer or company from which the pump was purchased if you are unable to solve the problem. Unauthorized personel is prohibited from disassembling or assembling the pump as it will probably result in inferiority in performance or damage to motor.

3. C A R E A F T E R O P E R A T I O N

YOU DO NOT NEED TO TAKE ANY SPECIAL CARE ON THE PUMP AFTER OPERATION, HOWEVER, YOU MUST BE WARN OF THE FOLLOWINGS:

- 3.1. If a freezing temperature is predicted, lift up the pump and re-install it in dry condition.
- 3.2. If pump is left for a long period of time without running, rust and other possible particals will accumulate in the pump, which will inevitably shorten the life of the pump.

4. APPLICATION

THE MOST EFFICIENT, VERSATILE AND COST-EFFECTIVE PRODUCTS YOU'LL EVER USE!

- Reduce all material found in the factory oil, in institutions and in light industrial.
- Recommended for domestic and light commercial

5. TROUBLE SHOOTING CHART

TO PREVENT SERIOUS ACCIDENTS, DISCONNECT THE POWER SUPPLY BEFORE INSPECTING THE PUMP:

Malfunction	Reason(s)	Countermeasure(s)
Pump fails to start	No power is supplied (power outage)	Contact the electric power company or an electrical repair shop
	Open circuit or poor connection of the cable	Check if there is an open circuit in the cable or wiring
	Impeller is obstructed	Inspect the pump and remove the obstruction
Pump starts but stops immediately, causing the motor protector to actuate	Impeller is obstructed	Inspect the pump and remove the obstruction
	Voltage drop	Correct the voltage to the rated voltage, or use an extension cable that meets the standard
	A 50Hz model is operated at 60Hz	Check the nameplate and replace the pump or impeller
	The strainer is obstructed, and the pump was operated dry for long hours	Remove the obstruction
	Motor abnormal	Repair the motor or replace with a new motor
	The pump is picking up too much sediment	Place a concrete block under the pump to prevent the pump from picking-up sediment
The pump's head and pumping volume is lower	The impeller is worn	Replace
	The hose may be clogged	Minimize the number of bends in the hose, (in an area with a large amount of debris, use the pump in a meshed basket)
	The strainer is obstructed or buried	Remove the obstruction.
	The motor rotates in reverse	Interchange the power supply terminal connection
The pump generates noise or vibration	The bearing of the motor may be damaged	To replace the bearing, contact the dealer from whom you purchased the equipment

6. SERVICE AND WARRANTY

If you can not find the reasons of the problem, please consult the authorized local dealer or company from which the pump was purchased. The pump has a 1 year warranty from the invoice date. Invoice is required for any warranty work.

7. TESTING

This light oil transfer system had been through all the necessary tests in the factory to detect all hydraulic, electric and mechanical weakness.

8. OPERATION

- The pump runs continuously in order to transfer a certain oil quantity at a constant pressure for it to be sufficient to the minimum requirements wanted. If an anormal pressure drop or if one of the float happend to show "low level", at the aspiration, the pump will stop. This will be made possible by a level-switch inside the tank.
- Some control of high and low level floats will make the start of one pump, after being requested to.
- The pump has an internal relief valve which allows the flow to deviate when the pressure in the system is too high, in which we inject, has reached the oil level wanted.
- When the level has reached it's required spot, the electric supply is stopped.
- In manual position, the pump can serve up for filling the tank.

9. INSTALLATION

The system is assemble and pre-wired entirely in factory, the contractor will have to join the suction manifolds and backflow to the existing piping with the help of flexible joints. The electrician-contractor will then have to complete the control panel electrical connection to the electrical source. Copies of the control panel electrical drawings have been included with the shipment. So, the job of the contractor are resumed to :

- To connect the electrical power to the command station
- To connect the pump's discharge to the system
- To connect the relief valve's outlet to the main system

10. S T A R T I N G - U P

The mechanical contractor will have to be sure of the systems good functioning by following carefully these instructions:

10.1. Be assured that the stop gates are in the opened position.

10.2. Minimum running timer

- Only if the system is provided with an adjustable minimum running timer. Put the timer to 0 before checking pressure switches operation (if required), and then, set it to 2 minutes. This timer prevents repetitive pump starting and stopping, when desired pressure is reached.

10.3. Level switch

- Place the pump selector button at "automatic" position. The pump should start immediately.

***** If the pump doesn't start?**

Adjust the level switch until the pump starts. After the pump have started, the adjustment level goal is to start the pump, in case of a low level.

When we have a low level, a red indicator lamp will light up, and the pump will stop.

10.4. Start-up level switch

- The switch allows the start-up of the pump.

***** If the pump doesn't start?**

The switch adjustment is too high or too low, adjust the float until the start-up of the pump and keep it running until the automatic level shut-down.

Check out the backflow gauge in order to establish which level the pump will stop.

11. S Y S T E M M A I N T E N A N C E

Control panel:

- Every weakness of one or some components should be reported to the manufacturer or a qualified electrician contractor. The manufacturer won't be held responsible of controls malfunctioning, after being repaired or maintained by un-qualified staff.

OPERATING INSTRUCTIONS

12. ROTARY VANE PUMPS

DESCRIPTION

The FLO FAB's rotary vane positive displacement pumps are used for handling of clean liquids at low flow and high pressure. Bronze pump models are designed for water pumping and moderately aggressive liquids. 304/303 Stainless Steel pump are for water pumping and aggressive liquids. For non-abrasive and non-flammable liquids that are compatible with pump components materials.

Pump body is built with two brass or two 303 Stainless Steel parts, with internal bypass relief valve, and graphite carbone pump chamber and vane. **CYB** and **CYS** models are delivered with a cleanable built-in strainer. 304 Stainless Steel shaft is machined to interface with notch carbonator motor shaft. The mechanical joint seal has a ceramic stationary seat, coal rotative face, Buna-N elastomer and stainless steel pieces. All pump bodies are machined bar clamp assembly. Bar clamp included.

APPLICATIONS

- Carbonated water for beverage dispensers
 - Ultra-filtration
 - Deionized water
 - Reverse-osmosis systems
 - Espresso coffee machines
 - Lubrication spraying
 - Light fuel oil
 - Insecticide spraying
 - Dispensing soap
 - Glycol Feed
 - Distilled water
 - Fire resistant fluids
 - Hydraulic oil
 - Steam cleaning machines with clean water
 - Cooling circulation
 - Pressure booster
 - Atomizing misting humidification systems
 - Laboratory pumps
 - Pilot plants
 - Boiler feeds
 - Water purification
 - Jockey fire pumps
- and many more applications...*

UNPACKING

Carefully inspect everything to possibly detect any damage that may have occurred while shipping. Check out for damage by turning the pump shaft. The shaft should turn easily.

DIMENSIONS

GALLONS PER HOUR AT PRESSURE IN POUNDS PER SQUARE INCH GAUGE (PSI)*												
FLO FAB Model		Inlet Size	20	40	60	80	100	120	140	160	180	200
Stainless Steel	Brass		PSI	PSI	PSI	PSI	PSI	PSI	PSI	PSI	PSI	PSI
CYS16-170	CYB16-170	3/8"	49 - 1/4hp	48 - 1/4hp	47 - 1/4hp	46 - 1/4hp	45 - 1/4hp	43 - 1/4hp	42 - 1/4hp	41 - 1/4hp	40 - 1/4hp	39 - 1/4hp
CYS16-295	CYB16-295	3/8"	111 - 1/4hp	110 - 1/4hp	109 - 1/4hp	108 - 1/4hp	107 - 1/3hp	105 - 1/3hp	104 - 1/3hp	103 - 1/3hp	102 - 1/2hp	101 - 1/2hp
CYS16-377	CYB16-377	3/8"	144 - 1/4hp	143 - 1/4hp	142 - 1/4hp	141 - 1/3hp	140 - 1/3hp	138 - 1/3hp	137 - 1/2hp	136 - 1/2hp	135 - 1/2hp	134 - 1/2hp
CYS16B-560	CYB16B-560	1/2"	201 - 1/4hp	200 - 1/3hp	198 - 1/3hp	197 - 1/3hp	196 - 1/3hp	195 - 1/2hp	194 - 1/2hp	193 - 1/2hp	192 - 1/2hp	190 - 1/2hp
CYS16-1026	CYB16-1026	1/2"	327 - 1/3hp	326 - 1/3hp	324 - 1/2hp	323 - 1/2hp	322 - 1/2hp	321 - 3/4hp	320 - 3/4hp	318 - 3/4hp	317 - 3/4hp	316 - 3/4hp

* Performance based on water at 68°F, no inlet pressure, motor speed of 1725 RPM. Flows will change in direct proportion to new speed vs. old speed

* FLO FAB pump performance in liters per hour (L/hr) and pressure in kilopascal (kPa).

GENERAL SAFETY INFORMATIONS

1. Know the pump application, limitations, and potential hazards.

CAUTION

DO NOT USE TO PUMP FLAMMABLE OR EXPLOSIVE FLUIDS SUCH AS GASOLINE, FUEL OIL, KEROSENE, ETC. DO NOT USE IN FLAMMABLE AND/OR EXPLOSIVE ATMOSPHERES. PUMP SHOULD ONLY BE USED WITH LIQUIDS COMPATIBLE WITH PUMP COMPONENT MATERIALS. FAILURE TO FOLLOW THIS WARNING CAN RESULT IN PERSONAL INJURY AND/OR PROPERTY DAMAGE.

2. Make certain that the power source (electric motor) conforms to the requirements of your equipment.
3. When wiring an electrically driven pump, follow all electrical and safety codes, as well as the most recent National Electrical Code (NEC) and the Occupational Safety and Health Act (OSHA) in the United States.

CAUTION

RISK OF ELECTRIC SHOCK!!!

TO REDUCE THE RISK OF ELECTRIC SHOCK, ELECTRIC MOTOR MUST BE ADEQUATELY GROUNDED TO A GROUNDED METAL RACEWAY SYSTEM, OR BY USING A SEPARATE GROUNDING WIRE CONNECTED TO BARE METAL ON THE MOTOR FRAME, OR TO THE GROUNDING SCREW LOCATED INSIDE MOTOR TERMINAL BOX, OR BY SOME OTHER SUITABLE MEANS. REFER TO THE MOST RECENT NATIONAL ELECTRICAL CODE (NEC) ARTICLE 250 (GROUNDING) FOR ADDITIONAL INFORMATION. ALL WIRING SHOULD BE DONE BY A QUALIFIED ELECTRICIAN.

4. Disconnect power before servicing. If the power disconnect is out-of-sight, lock in the open position and tag it to prevent unexpected application of power. Failure to do so could result in fatal electrical shock!
5. Release all pressure within the system before servicing any component.
6. Drain all liquids from the system before servicing.
7. Secure the discharge line before starting the pump. An unsecured discharged line will whip, possibly causing personal injury and/or property damage or puncture.
8. Check piping before each use, making certain that all connections are secure.
9. Periodically inspect pump and system components. Perform routine maintenance as required.
10. Provide a pressure relief system on pumps whose discharge line can be shut off or obstructed.
11. **Personal Safety:**
 - 11.1. Wear safety glasses at all times when working with pumps.
 - 11.2. Wear a face shield and proper apparel when pumping hazardous chemicals.
 - 11.3. Keep work area clean, uncluttered and properly lighted. Replace all unused tools and equipment.

- 11.4. Keep visitors at a safe distance from the work area.
- 11.5. Make workshop child proof with padlocks, master switches, and by removing starter keys.
12. All wiring should be performed by a qualified electrician.
13. Protect electrical cord from sharp objects, hot surfaces, oil and chemicals. Avoid kinking the cord. Replace or repair damaged or worn cords immediately.
14. Keep fingers and foreign objects away from ventilation and other openings. Do not insert any objects into the motor.
15. Use wire of adequate size to minimize voltage drop at the motor.
16. Do not touch an operating pump or motor. Modern pumps and motors are designed to operate at high temperatures.

C A U T I O N

DO NOT HANDLE A PUMP MOTOR WITH WET HANDS OR WHEN STANDING ON A WET OR DAMP SURFACE OR IN WATER.

INSTALLATION - FOR EXISTING INSTALLATION

1. Shut off electrical power supply to pump. Drain system (or close isolation valves on both sides of pump and relieve pressure).
2. Remove inlet and outlet connections at pump.
3. Loosen clamp that mounts pump to motor.
4. Remove pump and clamp.
5. Check that slot in motor shafts is not worn excessively or broken.

I M P O R T A N T

CHECK THAT ROTATION OF NEW PUMP MATCHES ROTATION OF OLD PUMP. IF NOT, CHANGE LOCATION OF INLET AND OUTLET PIPING AND CHANGE MOTOR ROTATION TO MATCH PUMP REQUIREMENTS. PUMP ROTATION CANNOT BE CHANGED. FAILURE TO DO SO COULD RESULT IN DAMAGE TO PUMP AND SYSTEM.

C A U T I O N

CHECK THAT HORSE-POWER METTES OR EXCEEDS WHAT IS REQUIRED BY PUMP. ROTATIONAL SPEED (RPM) OF MOTOR LISTED ON NAMEPLATE SHOULD MATCH SPEED REQUIRED BY PUMP; MAXIMUM RPM IS 1725. FAILURE TO DO SO COULD RESULT IN PROPERTY DAMAGE AND SEVERE PERSONAL INJURY OR DEATH.

6. Install pump and clamp on motor. Check that pump is aligned and not cocked in registered fit hub of motor.
7. Tighten clamp, checking that pump is secure.
8. Remove inlet and outlet port protection plugs.

I M P O R T A N T

BEFORE PROCEEDING, CHECK THAT FLUID AND SYSTEM ARE CONTAMINANT FREE. FAILURE TO DO SO COULD RESULT IN PREMATURE OR UNSATISFACTORY LIFE OF PUMP.

9. Install fittings with pipe sealant tape or soft paste on pump, taking care not to over-tighten fittings. Tighten just enough to prevent leakage. While tightening, make sure you do not put pressure on pump body or motor mounting, which would cause either to distort.
10. Double check fit of all parts, rotation of pump and motor, motor HP and RPM.
11. Fill system, including pump, with clean fluid.

I M P O R T A N T

PUMP MUST NOT RUN DRY. FAILURE TO DO SO COULD RESULT IN DAMAGE TO PUMP.

12. Reconnect power.
13. Turn system on and check for leaks and operation.

INSTALLATION - FOR NEW INSTALLATION

C A U T I O N

CHECK THAT HORSE-POWER MEETS OR EXCEEDS WHAT IS REQUIRED BY PUMP. ROTATIONAL SPEED (RPM) OF MOTOR LISTED ON NAMEPLATE SHOULD MATCH SPEED REQUIRED BY PUMP. FAILURE TO DO SO COULD RESULT IN PROPERTY DAMAGE AND SEVERE PERSONAL INJURY OR DEATH.

1. Align pump and clamp on to motor.
2. Tighten clamp, checking that pump is secure and aligned.
3. Remove inlet and outlet port protection plugs.
4. Install fittings with pipe sealant tape or soft paste on pump, taking care not to over-tighten fittings. Tighten just enough to prevent leakage. While tightening, make sure you do not put pressure on pump body or motor mounting, which would cause either to distort.

5. Double check fit of all parts, rotation of pump (check on pump) and motor, motor HP and RPM.
6. Install pump and motor following motor installation instructions.

C A U T I O N

FAILURE TO FOLLOW MOTOR INSTALLATION INSTRUCTIONS COULD RESULT IN FATAL ELECTRICAL SHOCK.

7. Fill system, including pump, with clean fluid.

I M P O R T A N T

PUMP MUST NOT RUN DRY. FAILURE TO DO SO COULD RESULT IN DAMAGE TO PUMP.

8. Turn system on and check for leaks and operation.

***** NOTE**

No replacement parts available.

MAINTENANCE

C A U T I O N

MAKE CERTAIN THAT THE POWER SOURCE IS DISCONNECTED BEFORE ATTEMPTING TO SERVICE OR DISASSEMBLE ANY COMPONENTS! IF THE POWER DISCONNECT IS OUT-OF-SIGHT, LOCK IT IN THE OPEN POSITION AND TAG TO PREVENT APPLICATION OF POWER.

1. CLEANING

Inspect suction strainer periodically, clean as necessary.

2. ROUTINE

Pump should be checked for proper operation daily, weekly, monthly, etc. If anything has changed (pump noise, motor noise, leaks, etc.) since the pump was new, the pump should be removed, examined and repaired if necessary. This is a difficult motor/pump to repair, therefore only qualified electricians or servicemen should attempt to repair this unit. Improper repair and/or assembly can cause problems with the electric motor used with this unit. See General Safety Information. Retighten V-band clamp screw as necessary. Use Loctite or similar thread sealant if screw keeps loosening.

3. FREEZING TEMPERATURE AND STORAGE

Pumps should not be used or stored in areas subject to freezing temperatures.

4. REPAIR

No replacement parts are available for these pumps.

5. LUBRIFICATION

None.

TROUBLE SHOOTING CHART

Malfunction	Reason(s)	Countermeasure(s)
Low capacity	Inadequate inlet	Increase piping size and/or increase fluid supply
	Rotation wrong	Change rotation
	Low motor RPM	Check voltage
	Bypass valve improperly set	Set valve at proper point
Leakage through weep holes; noise	Seal damage	Replace pump, also clean system
	Inadequate inlet	Increase piping, increase fluid, lower temperature of fluid to prevent cavitation, and/or clean strainer
	Bypass valve improperly set	Lower setting below 200 PSIG and/or tighten lock nut
	Air (cavitation)	Tighten inlet pipe connections
	Misalignment	Loosen clamp and make sure pump and motor are seated properly, and/or retighten clamp
Binding	Misalignment	Loosen clamp and make sure pump and motor are seated properly, and/or retighten clamp
	Mineral deposits	Remove deposits by cleaning pump
	Grit, foreign matter	Remove by cleaning and eliminate from fluid supply by installing strainer

Read all instructions thoroughly

INSTRUCTION

PRESSURE SWITCH "TYPE SNS·HNS"



PREFACE

Failure to read and follow all instructions carefully before installing or operating this PRESSURE CONTROLS could cause personal injury and/or property damage. Save these instructions for future use.

NOTE FOR SAFETY

⚠ WARNING

- Do not open a cover during power on. Otherwise fingers may touch to alive parts and cause of electric shock.
- Make sure to power off the Product before wiring. It will be cause of electric shock.
- Do not drop water on the Product. Water drip will touch to the alive parts makes earth circuit and electric shock accident may result.
- Use the attached screws (M4×0.7×8 with washer) when installing a main body. In case of missing the attached screws, use a screw with insert depth of less than 5mm. Otherwise the screw will touch to the alive parts and may cause electric shock or malfunction.

MOUNTING

Standard bracket is regularly supplied. Controls may be mounted to wall surface or panel board by 4 mounting holes provided in the back of the case (M4×0.7). Before and during installation, be careful about the below Caution, otherwise it may cause failure or defect.

CAUTION

- Do not move any screw or parts other than adjusting screws and terminal screws.
- Do not drop the Product.
- Do not paint the Product.
- Be sure to remove dust or other foreign particles in the pipes before connecting the Product to the pipe.
- When connecting pipes to the element, be sure to use two spanners at the hexagonal portion of bellows element in order to avoid deformation of the element.

MOUNTING CONDITIONS

The operation of the Product should follow the below conditions, otherwise it will be cause of malfunction or performance decrement.

In case of using to exceed the below conditions, contact the Company.

- Install the Product where vibration is less than 9.8m/s².
- Use the Product with the below temperature ranges.
Ambient temperature: -20°C to 70°C, Fluid temperature: -20 to 120°C
- Use the Product with fluid which does not corrode the bellows cap (copper alloy). In case of usage with any corrosive fluid and steam, use the model with Stainless Steel bellows.
- Use the Product within the Maximum working pressure range. And, install the Product where no pressure pulsation, excessive pressure fluctuation or pressure hummer generates.

WIRING

Electrical wires should be connected to the terminal screws of micro switch according to a particular application. Refer to the wiring diagrams for the details, and be careful about the below points.

- Use the Product within the electrical ratings.
- Use the fixed terminal screw (M4×0.7×6).

WIRING DIAGRAM

TYPE : SNS

TYPE : HNS

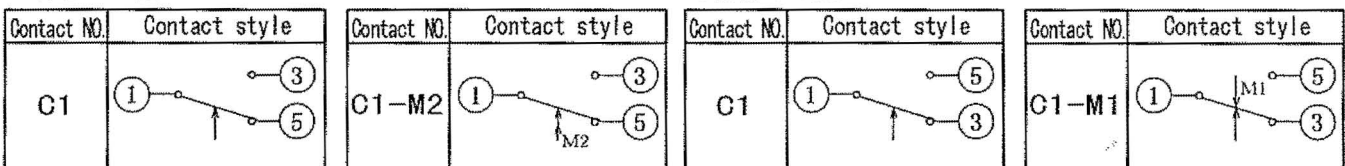

↑ : Operating direction on pressure increase.

M2 ↑, M1 ↓ : Operating direction on manual reset.

ELECTRICAL RATINGS

Terminals	Small Current (TYPE:0C)				Medium Current (TYPE:1C)				Large Current (TYPE:2C)				
	1-3		1-5		1-3		1-5		1-3		1-5		
AC Voltage	120V	240V	120V	240V	120V	240V	120V	240V	120V	240V	120V	240V	
Full Load	0.075A		0.075A		10A		10A		8A	20A	17A	16A	8A
Locked Rotor	0.075A		0.075A		60A		60A		48A	120A	102A	96A	48A

OPERATION/ADJUSTMENT

TYPE : SNS

Adjustment procedure: Firstly, set the operation value with the range adjusting screw while pressure is rising. Then, set the operation value with the differential adjusting screw while pressure is decreasing. With turning the range adjusting screw to counterclockwise, the setting pressure rises. With turning the differential adjusting screw to clockwise, the differential enlarges. By turning these two adjusting screws, the desired setting pressure and differential are obtained.

Note : The manual reset series is not adjustable in the field. At the pressure decreasing, the contact operates automatically. At the pressure rising, the contact should be manually reset.

TYPE : HNS

Adjustment procedure : Set the operation value with the range adjusting screw while pressure is rising. With turning the range adjusting screw to clockwise, the setting pressure rises and the returning pressure also rise alongside.

Note : In case of the manual reset series, the contact operates automatically at the pressure rising. At the pressure decreasing, the contact should be manually reset.

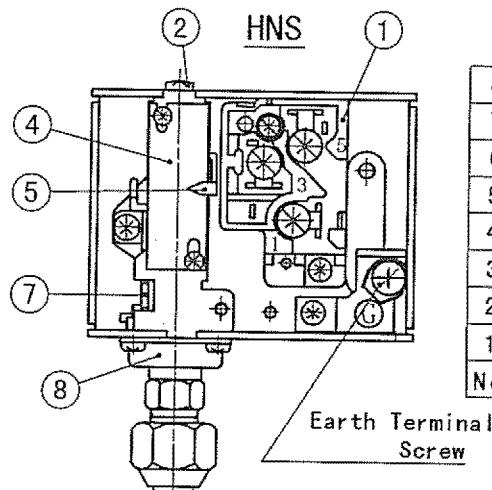
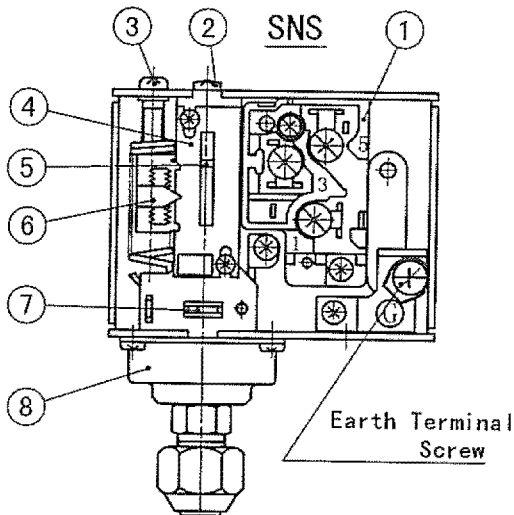

8	Bellows cover
7	Operation plate
6	Differential pointer
5	Range pointer
4	Scale plate
3	Differential Adjusting Screw
2	Range Adjusting Screw
1	Micro Switch
No.	PART NAME

OPERATION CHECK

Install and calibrate the product correctly and then check its operation to confirm correct function of the whole system when using.

LIMIT ON APPLICATION

The Product is not designed nor manufactured for an use in such equipment or system that is intended to be used under such circumstances that may affect human life.

For application requiring extreme high reliability, please contact the Company first.

SCOPE OF WARRANTY

Unless otherwise agreed by the parties, warranty period of the product shall be one year after date of delivery to Buyer. In case of failure attributable to the Company within such period, the product shall be repaired or replaced without charge, provided that any one of followings are out of the warranty:

- ① Improper handling or application by user.
- ② Modification or repair by other than Company.
- ③ Any failure to be caused by acts of God, fire, storm or the like, war, riot, or the like and other causes beyond the control of the Company.

Warranty described in this paragraph means the warranty for the product itself and does not include warranty for any consequential damage arising out of or occasioned by a defect or failure of the product.

55-5, Wakamiya 2 chome, Nakano-ku,
Tokyo 165-8907 Japan
Tel: +81 3 3330-8161 Fax: +81 3 3330-8175
E-mail: inter@saginomiya.co.jp
URL: <http://www.saginomiya.co.jp>

SAGINOMIYA
SEISAKUSHO, INC.



FLO FAB



www.flofab.com

**Manufacturer of Pumps, Tanks, Heat Exchangers & Accessories
for HVAC Market After-Sales Parts and Services**

FLO-FAB INC
LAKE WORTH,
FLORIDA, USA

SEPTEMBER 2009