

THE GLYCOL MAKE-UP PACKAGE THAT OFFERS BOTH PERFORMANCE AND RELIABILITY!



Glycol Make-Up Package

WITH ADDED FEATURES

PREVENT MAJOR FLOODS
PROVIDE LEAK DETECTION
WATER OR MIX OF WATER AND GLYCOL
RUGGED SELF-PRIMING PUMP

NEW

SYSTEM FILLING
NOW EASIER
THAN EVER WITH
THE INTEGRATED



HYDRONIC SYSTEM FEEDERS

Flo Fab's S-GLY are economical yet rugged, compact and easy to use fluid feeders for small closed-loop systems. Their function is to automatically supply pressurized water or a water/glycol mixture to a closed-loop space heating, chilled water, snowmelt, solar, radiant heating or process control system, to ensure that minimum system pressure levels are maintained. The optional remote alarm panel kit will provide an audible and visual indication of a system leak.

www.flofab.com

TABLE OF CONTENTS

ECO SECTION

FEATURES AND BENEFITS	2
SPECIFICATIONS	3
DIMENSIONS	4
OPTIONS	5
APPLICATIONS	6
FEATURES AND COMPONENTS	7
SELECTION CHARTS	8
DESCRIPTION/APPLICATIONS/CONSTRUCTION/OPERATION	9
STANDARD PUMP SPECIFICATIONS	10
TYPICAL SPECIFICATIONS	11

HISTORY

Flo Fab was established in 1981 by Denis Gauvreau who created and developed the products line and constantly being perfected by Marc Gauvreau, as well as by a team of professional engineers and designers. It's a combination of existing designs from several renowned products and the innovative ideas of a new generation professionals.

Through the years, Flo Fab has acquired several companies and service entities including : AQUA-PROFAB (ASME Tanks manufacturer), MÉNARD, LÉONARD ÉLECTRIQUE, PMA. , Furthermore Flo Fab purchased equipment, fabrication designs and patterns from IDEALCO, a manufacturer of shell and tube type heat exchangers.

The after sales services, sales, engineering, R&D, production, quality control, accounting and administration departments of all the above companies share the same location.

In December 2014, Marc Gauvreau, son of the founder, acquired all shares of The company. Flo Fab and is constantly investing in new state of the art innovations new product like the XRI series and Prefab Skid for Hydronic Heating & cooling system, pumping systems. This has allowed Flo Fab to retain competent and experienced staff of professionals with varied and specialized abilities that constantly work on improving our existing products and add new engineered solutions that exceeding customer's expectations .

Flo Fab has grown quite rapidly and now proudly offers of a wide range of products available directly from one manufacturer. This includes pumps & pump packages, tanks, heat exchangers & hydronic accessories. This allows each project stakeholders to enjoy economical savings, peace of mind, best value for their investment and optimized total cost of ownership.



• Features and Benefits

Features	Benefits
Filling valve NEW	System filling with an independant glycol container is now easier than ever with the 3-way valve and filling kit (#S-GLYFILLINGKIT), unique to Flo Fab's S-GLY design.
Prevent major floods	In the event of a major system leak, only the content of the storage tank will be pumped into the system.
No direct connection to potable water supply	Eliminates the need for backflow prevention devices.
Provide leak detection	Dropping solution level in the storage tank warns of developing system leak.
Alarm kits	The optional remote alarm kit alerts the user if there is a system leak, allowing quick corrective actions.
Easy maintenance	Just pour back in the liquid drained for maintenance.
By-pass valve	Used to set prv pressure and for manual agitation of solution
Connected with a flexible braided hose	To isolate from vibration of the system.
Rugged self priming pump	Can run dry for extended periods and be used to fill your system. Its components are chemical resistant and certified to meet UL and CSA norms.



• Specifications

(Four Sizes - Also Available for Solar System)

MODELS	Capacity	
	Gal	L
S-GLY6	6	22.7
S-GLY18	18	68.1
S-GLYLC55	5	208.0
S-GLYLC100	100	379.0

120 Vac/1 ph/60 Hz, standard plug with 6 ft (1.8 m) cord.

Level float switch with piggyback plug.

Level switch stops the pump if fluid level in the tank is too low.

Easy to adjust PRV to maintain system pressure (up to 60 psig (413 kPa) and 100 psig (690 kPa) for solar systems).

- A) Flexible braided hose
- B) 3/4" opening for relief valve
- C) By-pass valve
- D) PRV
- E) Pump
- F) Liquid filled pressure gage (0-100 PSI)
- G) 3-way filling valve



Alarm Kits

Alarm panel kit (#S-GLYAL): The kit includes a low level float switch and an alarm panel. The float kit includes a 10' (3 m) cable for connection to the remote panel. The alarm panel includes: NEMA 1 indoor enclosure, 6' (1.8 m) power cord with 120V plug, 12 VAC control circuit with 9 Volt battery back-up (battery included), power and alarm indicator lights, silence and test buttons.



Remote alarm kit (#S-GLYDC): The kit consists of auxiliary alarm contacts (1-NO). It includes a float with a 10' (3 m) cable for connection to the remote panel by others.



• Dimensions

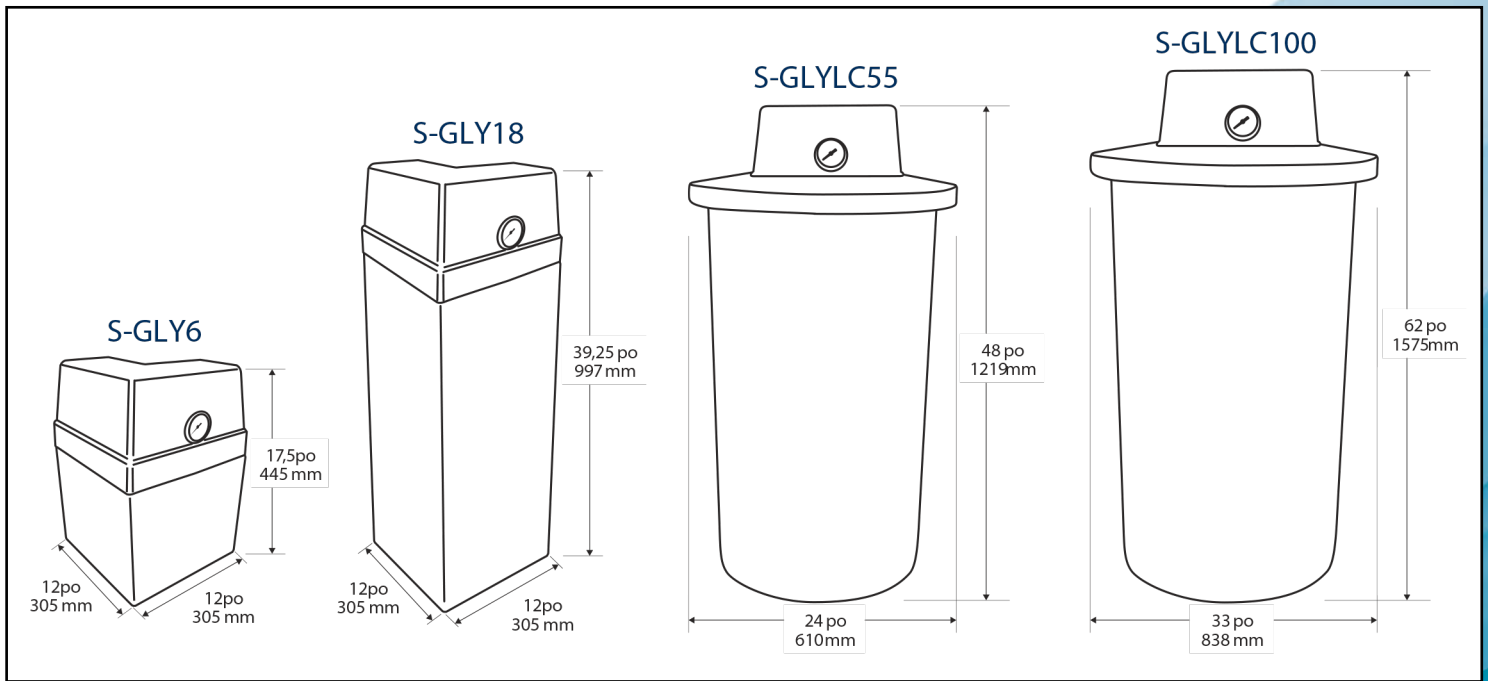

S-GLY6										
Capacity		Electrical	Pump	Discharge Connection	Weight empty		Weight full		Pressure	
gal	L				lbs	kg	lbs	kg	psig	kPa
6	22.7	120 Vac/60 Hz plug	1.6gpm (6L/m)	1/2" FPT	16	7.4	66	30	0-60	0-413
S-GLY6S										
"	"	"	"	"	"	"	"	"	0-100	0-689

S-GLY18										
Capacity		Electrical	Pump	Discharge Connection	Weight empty		Weight full		Pressure	
gal	L				lbs	kg	lbs	kg	psig	kPa
18	68.1	120 Vac/60 Hz plug	1.6gpm (6L/m)	1/2" FPT	25	11.4	175	79.5	0-60	0-413
S-GLY18S										
"	"	"	"	"	"	"	"	"	0-100	0-689

S-GLYLC55										
Capacity		Electrical	Pump	Discharge Connection	Weight empty		Weight full		Pressure	
gal	L				lbs	kg	lbs	kg	psig	kPa
55	208	120 Vac/60 Hz plug	1.6gpm (6L/m)	1/2" FPT	35	16	494	224	0-60	0-413

S-GLYLC100										
Capacity		Electrical	Pump	Discharge Connection	Weight empty		Weight full		Pressure	
gal	L				lbs	kg	lbs	kg	psig	kPa
100	379	120 Vac/60 Hz plug	1.6gpm (6L/m)	1/2" FPT	49	22	884	401	0-60	0-413

*Pressure : 0-100 PSIG (0-690 kPa) on solar models.

• Options

#S-GLYAL
Remote alarm panel kit: low level switch and remote panel with 9 V battery back-up



#S-GLYDC
Float switch and auxiliary dry contact (NO) for remote low level alarm



#BH72
72 inches braided hose to connect GMP to system



#S-GLYFILLINGKIT
Re-usable hose with strainer to fit S-GLY6 and S-GLY18 filling valve

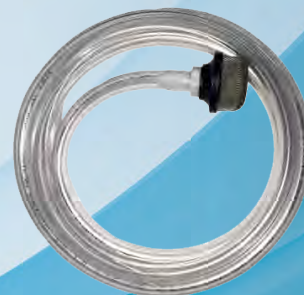

#S-GLY6WMS
Wall mounting shelf for GMP6

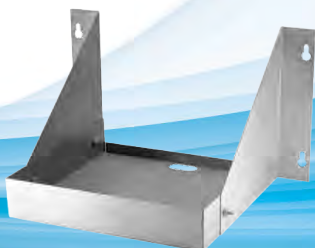

Expansion Tanks and Accessories

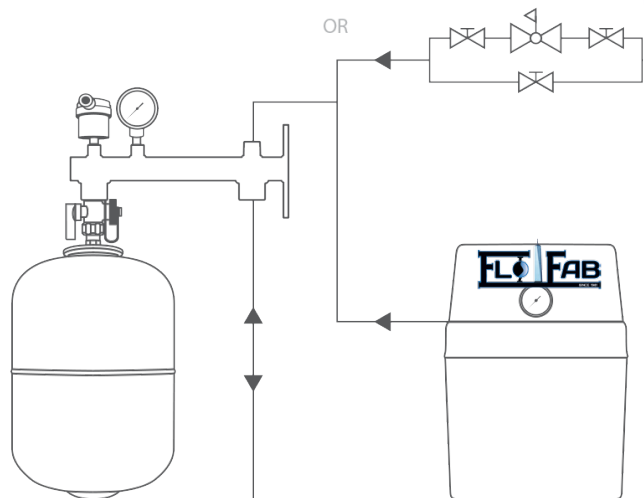



● Applications

FLO FAB S-Gly, D-Gly or T-Gly pumping sets offer several advantages over jobsite assembly of components. The most important advantage is that FLO FAB selects the unit and mounts all the components in house therefore eliminating the margin of error.

Simplex models are normally-stocked and cover most applications. Other models can be manufactured to meet the requirements for a specific application. A shop drawing and a wiring diagram, both incorporating a list of components, are prepared for approval prior to fabrication. The electrical control system may vary from one magnetic motor starter for each pump, indicator lights, control transformers and a system control pressure switch (see EP panel for complete details). When pump operation is intermittent, a control is frequently used to alternate pumps (on duplex units only) and automatically turns on the back-up pump in case of malfunction.

The CYS model pump is an industrial pump. This pump has become the industry standard in glycol fill units. The CYS pump features a new open-core design that provides improved performance at higher speeds and pressures. The rotor head is hydraulically balanced to provide minimum end clearance, assuring instant priming and instant capacity over a wide viscosity and pressure range. The pump is provided with a new improved mechanical face-type seal and Teflon impregnated outboard design for direct drive. These seals are capable of handling inlet pressures as high as 200 PSI at standard 1750 RPM motor speeds. As shown in the tables herein, this pump is available in five sizes. Each pump is provided with an internal relief valve. FLO FAB Simplex glycol fill units are ideal in heating systems and for those applications where the requirements for a continuous pressure and supply of glycol is required.

1. For each closed glycol system, you should have a FLO FAB Series «GLY» automatic Glycol Pressurization unit. This system is used to automatically compensate for possible glycol leakage in a closed system.

2. Each unit has the following items:

- Polyethylene tank with cover
- Adjustable connections for water or Glycol
- Low-level float and internal pump relief valve
- A separate external relief valve to return the glycol solution to the holding tank.

3. Systems have stainless steel rotary vane type pump(s) with electric closed coupled motor(s) :

- Control panel Nema 1 with piston type pressure switch
- 3 position selector (H.O.A.)
- Low-level indicator light
- Low-level shut-off float
- Dry contact for remote low level alarm signal (5 amps) (see EP panel for complete details)
- Dry contact for remote low level alarm signal
- Isolating ball valves
- Pump discharge check valve(s)
- Liquid filled pressure gauge
- Water hammer arrestor
- Factory-assembled, wired and tested prior to shipping

Features and Components

FEATURES

- Simplex, Duplex or Triplex Units
- Self-feed transfer unit (transfers glycol from the tank to the system)
- Ability to fill system directly from external supply
- Ability to fill tank from external drum

COMPONENTS

1. Pump(s) Closed-coupled rotary vane
2. Motor(s)
3. Polyethylene Tank with access cover
tank capacity:
25 gallons
53 gallons
106 gallons
200 gallons
4. Simplex, Duplex and
Triplex Control Panel
(see EP panel for proper selection)
5. System Pressure Switch(es)
6. Pump internal Relief Valve(s)
7. External Pressure Relief Valve(s)
8. Low-level shut-off float
9. Water hammer arrestor
10. Liquid filled Pressure Gauge(s)
11. Ball Valve(s)
12. Check Valve(s)
13. Hose fill valve(s) with cap
(transfers glycol from external
supply drum to tank or system)
14. Copper Piping
15. PVC base-plate for pump(s)
and motor(s)
16. Electrical connection

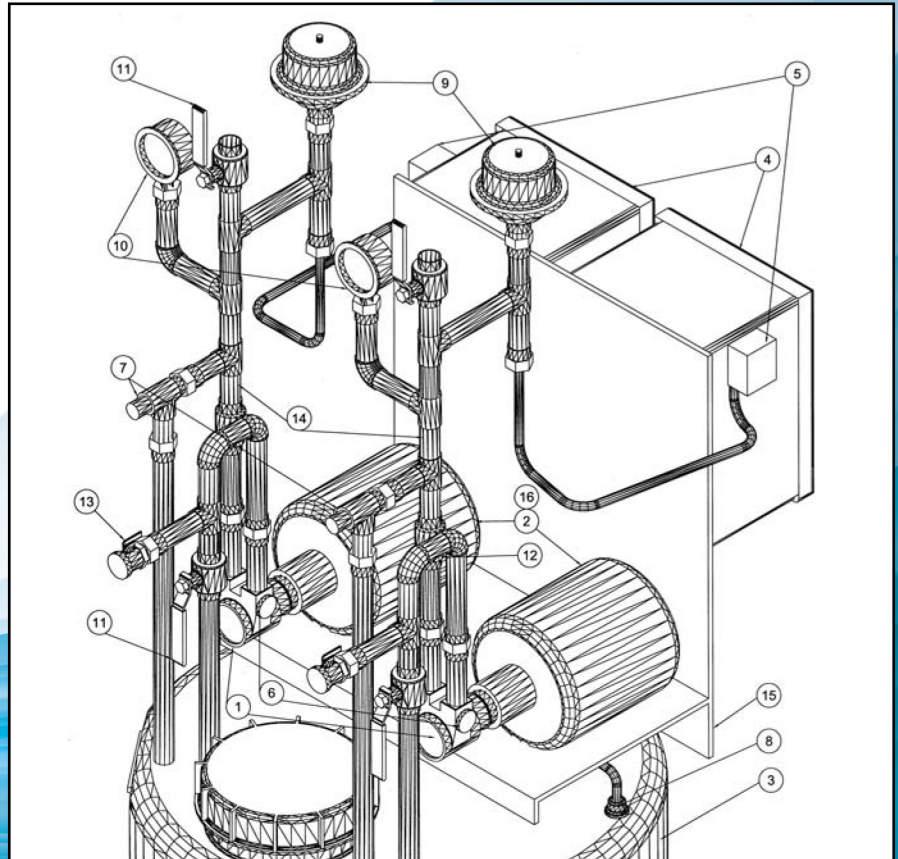



Selection Charts

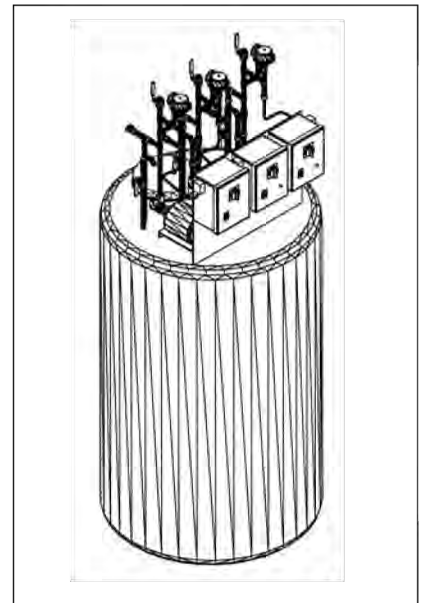
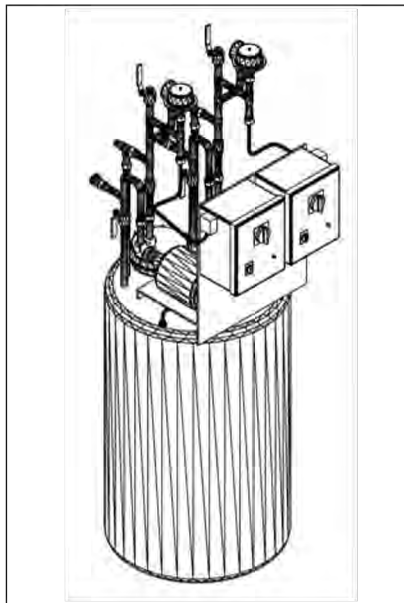
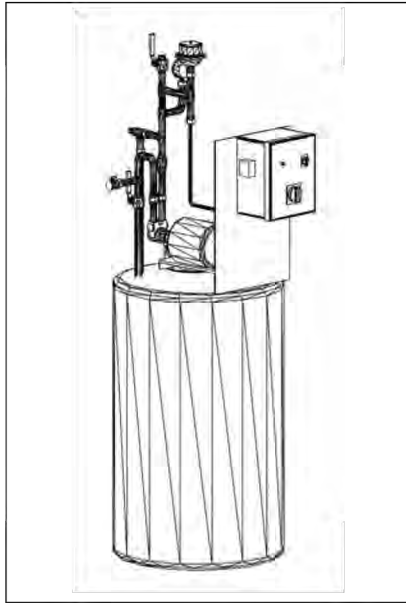

Series Tank Size (Gal.) Pump Model
Simplex: S - GLY - _____ - CYS16 - _____
 Example: S - GLY - 25 - CYS16 - 170

Series Tank Size (Gal.) Pump Model
Duplex: D - GLY - _____ - CYS16 - _____
 Example: D - GLY - 25 - CYS16 - 170

Series Tank Size (Gal.) Pump Model
Triplex: T - GLY - _____ - CYS16 - _____
 Example: T - GLY - 25 - CYS16 - 170

Simplex Unit Selection Chart for Tank

√	Unit Model	Tank Capacity		Diameter		Height		Weight	
		Gal	L	In	mm	in	mm	lbs	kg
	S-GLY-25	25	94	18	457	29	737	70	31
	S-GLY-53	53	200	22	559	39	990	90	40
	S-GLY-106	106	400	26	660	44	1118	115	52
	S-GLY-200	200	754	30	762	43	1092	125	57

Duplex Unit Selection Chart for Tank

√	Unit Model	Tank Capacity		Diameter		Height		Weight	
		Gal	L	In	mm	in	mm	lbs	kg
	D-GLY-25	25	94	18	457	29	737	70	31
	D-GLY-53	53	200	22	559	39	990	90	40
	D-GLY-106	106	400	26	660	44	1118	115	52
	D-GLY-200	200	754	30	762	43	1092	125	57

Triplex Unit Selection Chart for Tank

√	Unit Model	Tank Capacity		Diameter		Height		Weight	
		Gal	L	In	mm	in	mm	lbs	kg
	T-GLY-25	25	94	18	457	29	737	70	31
	T-GLY-53	53	200	22	559	39	990	90	40
	T-GLY-106	106	400	26	660	44	1118	115	52
	T-GLY-200	200	754	30	762	43	1092	125	57

• Description

Rotary vane positive displacement pumps run quietly and require no maintenance. For clean fluids at low flow and high pressure. Pumps are designed for pumping water/glycol and moderately aggressive liquids. 304 Stainless Steel pump is superior for non-abrasive are designed for pumping water/glycol and moderately aggressive liquids. 304 Stainless Steel pump is superior for non-abrasive and non-flammable liquids that are compatible with pump component materials. Maximum operating temperature is 180°F.

• Applications

- Carbonated water for beverage dispensers
- Ultra-filtration
- Deionized water
- Reverse-osmosis systems
- Espresso coffee machines
- Lubrication spraying
- Light fuel oil
- Insecticide spraying
- Dispensing soap
- Glycol Feed
- Distilled water
- Fire resistant fluids

- Hydraulic oil
- Steam cleaning machines with clean water
- Cooling circulation
- Pressure booster
- Atomizing misting humidification systems
- Laboratory pumps
- Pilot plants
- Boiler feeds
- Water purification
- Jockey fire pumps
- and many more applications...

• Construction

- Two piece 304 Stainless Steel body
- Built-in bypass relief valve
- Carbon graphite pump chamber and vanes
- Available with and without built-in cleanable strainer
- 71 Mesh Filter
- 304 Stainless Steel
- Hub dimensions for special FLO FAB pump motors

- Clamp included 304 Stainless Steel body
- Carbon graphite pump chamber
- 304 Stainless Steel rotor and shaft
- Carbon graphite vanes
- Carbon rotating seal
- Ceramic stationary seal with Buna N bellows

• Operation

This unit is used to automatically compensate for possible glycol leaks in a closed system. The pressure switch has an adjustable pressure range for various pressure requirements. Should pressure increase to above the setting of the adjustable pressure relief valve, the relief valve will open allowing the excess pressure/fluid to return to the tank. When the pressure switch has reached its set point, the pump is turned off. The pump can also operate continuously if the selector switch is positioned to manual. The pump can be used as a transfer pump from a barrel to fill the tank by removing the cap on the hose valve and adjusting the relief valve at low pressure, and this will automatically fill the polyethylene tank. When the poly tank is full, you can disconnect the hose, re-install the hose valve cap and re-adjust the relief valve to the required setting. A low-level float is provided in the tank. Should the level of glycol become dangerously low, it will disable the pump to prevent it from operating without fluid, and send an alarm signal.



Standard Pump Specifications

Body	-	Stainless Steel
Capacity	-	49 to 316 GPH
Nominal Speed	-	1725 RPM
Maximum Discharge Pressure	-	200 PSI
Rotation	-	Clockwise Rotation
Dry-Weight	-	2.75 lbs
Self Priming (water)	-	max. 6 feet

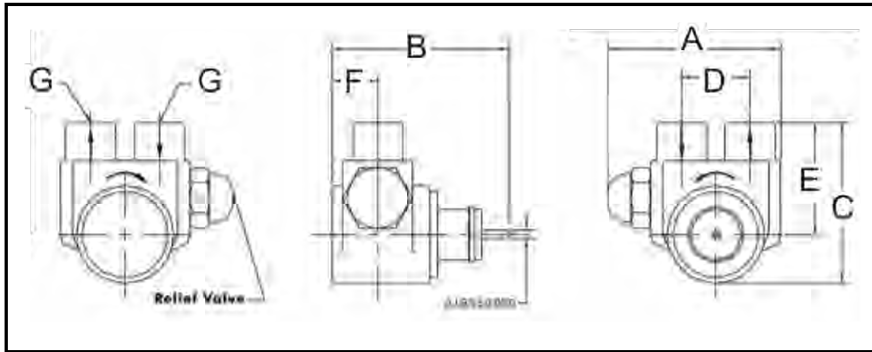

Dimensions

✓	Unit Model	A		B		C		D		E		F		G(NPT)	
		in	mm	in	mm	in	mm	in	mm	in	mm	in	mm	in	mm
	CYS16-170	3 7/16	91	3 7/8	99	3 1/2	95	1 1/2	40	2 7/16	61	1	25	3/8	9
	CYS16-295	3 7/16	91	3 7/8	99	3 1/2	95	1 1/2	40	2 7/16	61	1	25	3/8	9
	CYS16-377	3 7/16	91	3 7/8	99	3 1/2	95	1 1/2	40	2 7/16	61	1	25	3/8	9
	CYS16-560	4 3/16	105	4 3/8	109	3 7/8	99	1 7/8	47	2 1/2	65	1 1/4	32	1/2	15
	CYS16-1026	4 3/16	105	4 3/8	109	3 7/8	99	1 7/8	47	2 1/2	65	1 1/4	32	1/2	15

✓	GALLONS PER HOUR AT PRESSURE IN POUNDS PER SQUARE INCH GAUGE (PSI)*											
	Models	In/ Out	20 PSI	40 PSI	60 PSI	80 PSI	100 PSI	120 PSI	140 PSI	160 PSI	180 PSI	200 PSI
	Stainless Steel	<input type="checkbox"/>	<input type="checkbox"/>	<input type="checkbox"/>	<input type="checkbox"/>	<input type="checkbox"/>	<input type="checkbox"/>	<input type="checkbox"/>	<input type="checkbox"/>	<input type="checkbox"/>	<input type="checkbox"/>	<input type="checkbox"/>
	CYS16-170	3/8	49 - 1/4hp	48 - 1/4hp	47 - 1/4hp	46 - 1/4hp	45 - 1/4hp	43 - 1/4hp	42 - 1/4hp	41 - 1/4hp	40 - 1/4hp	39 - 1/4hp
	CYS16-295	3/8	111 - 1/4hp	110 - 1/4hp	109 - 1/4hp	108 - 1/4hp	107 - 1/3hp	105 - 1/3hp	104 - 1/3hp	103 - 1/3hp	102 - 1/2hp	101 - 1/3hp
	CYS16-377	3/8	144 - 1/4hp	143 - 1/4hp	142 - 1/4hp	141 - 1/3hp	140 - 1/3hp	138 - 1/3hp	137 - 1/2hp	136 - 1/2hp	135 - 1/2hp	134 - 1/2hp
	CYS16-560	1/2	201 - 1/4hp	200 - 1/3hp	198 - 1/3hp	197 - 1/3hp	196 - 1/3hp	195 - 1/2hp	194 - 1/2hp	193 - 1/2hp	192 - 1/2hp	190 - 1/2hp
	CYS16-1026	1/2	327 - 1/3hp	326 - 1/3hp	324 - 1/2hp	323 - 1/2hp	322 - 1/2hp	321 - 3/4hp	320 - 3/4hp	318 - 3/4hp	317 - 3/4hp	316 - 3/4hp

● Typical Specifications

The contractor shall furnish and install a Simplex, Duplex or Triplex glycol fill system model S-GLY, D-GLY or T-GLY as designed and manufactured by FLO FAB. The system shall be capable of automatically compensating for possible glycol leaks in a closed system. Maximum discharge pressure should not exceed 200 PSI and maximum operating temperature is 180°F.

The system shall be a factory-manufactured one-piece assembly and shall contain: a tank, pump(s), check valve(s), ball valves, hose fill valve(s), water hammer arrestor, independently mounted relief valve(s), control panel(s), a low-level switch and all necessary electrical controls and accessories for a complete automatic operation.

PUMP

The rotary vane positive displacement pump(s) series CYS shall be constructed 304 stainless steel, and will have a built-in By-Pass relief valve as manufactured by FLO FAB. The pump(s) shall have carbon graphite vanes, carbon rotating seal, ceramic stationary seal with Buna N bellows and stainless steel spring. The electric close-coupled motor(s) shall be opendrip-proof motor, standard NEMA construction. Single-phase fractional H.P. motor to include built-in thermal overload protection and stainless steel shaft. Motor bearings shall be sealed and factory-greased for extra long trouble-free operation.

RELIEF VALVE

Adjustable pressure relief valve, with discharge piped to tank.

BALL VALVES

All ball valves shall be of bronze construction series LBV as manufactured by FLO FAB and shall be sized to minimize the pressure drop through the system.

SILENT CHECK VALVE

On each pump discharge a silent bronze check valve series STB as manufactured by FLO FAB shall be supplied.

PRESSURE GAUGE

A FLO FAB liquid-filled pressure gauge shall be installed on the discharge of the pump(s).

POLYETHYLENE TANK WITH COVER

A polyethylene tank with inspection cover shall be supplied as manufactured by FLO FAB. The tank capacity shall be: 25 gallons, 53 gallons, 100 gallons or 200 gallons.

CONTROLLER(S)

NEMA 1 Simplex control panel(s) shall include: manual transfer, HOA, pilot lights, low-level shut-off float and a system pressure switch. The system pressure switch shall have an adjustable pressure range in order to increase and decrease pressure according to system requirements. When the pressure switch has reached its set point, the pump is turned off. The low-level float installed in the tank shall disable the pump(s) and send an alarm signal should the glycol level become dangerously low.

ADDITIONAL FEATURES

The glycol fill system shall have a hose bib connection to allow its pump to fill the system directly from the external supply drum and to fill the tank directly from external supply drum.

We are proud supplier for the following completed and on going projects :



McGill College
845 Rue Sherbrooke O,
Montréal, QC H3A 0G4



51 Astor
25 Cooper St, New York,
NY 10034, United States



Telus Rimouski
419 Boul Jessop
Local 620, Rimouski, QC



La Maison Simons
977 Rue Ste-Catherine O,
Montréal, QC H3B 4W3

Sales and Service:

Quebec, Canada
Tel. : (450) 621-2995
Fax : (450) 621-4995

Lake Worth
Florida, USA
33467-5749

Toronto, Canada
Tel. : +1 (647) 544-2995

www.flofab.com

SERVICE 24/7 : parts@flofab.com



<http://www.arcomnet.com/masterspec/>