

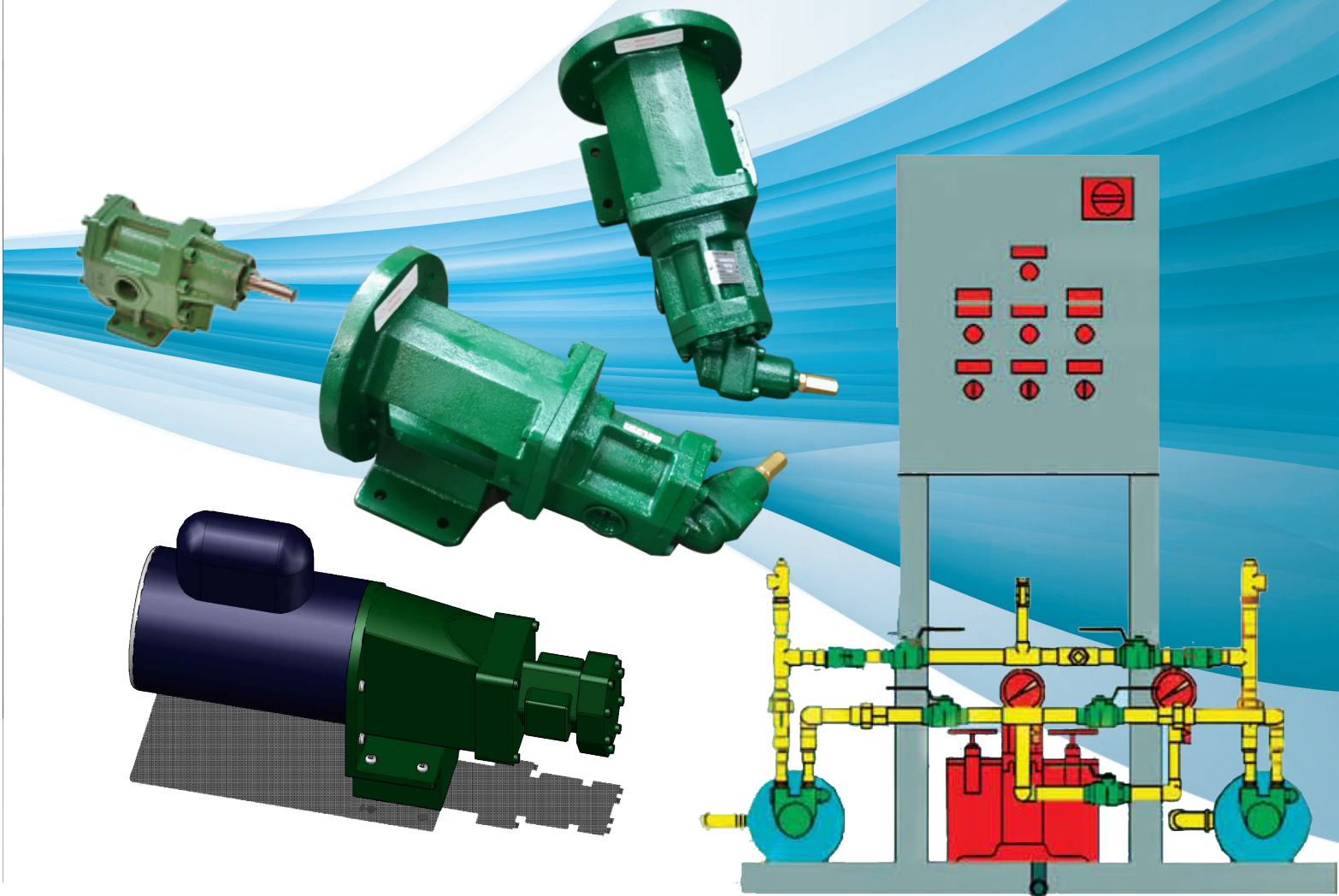

Fuel Oil Transfer Systems

FOM SERIES

G & H HELICAL SERIES



www.flofab.com
001-cat-2016-glyc

Go to www.flofab.com in Our Products Section to see the Master Spec - <http://www.arcomnet.com/masterspec/>

TABLE OF CONTENTS

FLO FAB S- FOM, D-FOM or Q-FOM	
APPLICATION & FEATURES.....	2
SELECTION CHARTS, FEATURES & COMPONENTS.....	3
DESCRIPTION/APPLICATIONS/CONSTRUCTION/OPERATION.....	4
PUMP STANDARD SPECS/DIMENSIONS/TYPICAL SPECIFICATIONS.....	5
FLO FAB G & H SERIES HELICAL	
FEATURES/EASY MAINTENANCE/PERFORMANCE.....	6
03G SERIES.....	7
05G SERIES.....	8
10G SERIES.....	9
18G SERIES.....	10
25G SERIES.....	11
35G SERIES.....	12
G & H SERIES HELICAL - DIMENSIONS.....	13
H SERIES HELICAL - CURVES.....	14
FLO FAB PUMP SERIES CYS16.....	15
LEVEL SWITCH L500 BRS/BUNA, 1 LVL, 2" NPT.....	16
LEVEL SWITCH L500 BRS/BUNA, 3 LVL, 2" NPT.....	17
VERTICAL MULTI-LEVEL - LIQUID LEVEL SWITCH SPECIFICATION SHEET.....	18

HISTORY

Flo Fab was established in 1981 by Denis Gauvreau who created and developed the products line and constantly being perfected by Marc Gauvreau, as well as by a team of professional engineers and designers. It's a combination of existing designs from several renowned products and the innovative ideas of a new generation professionals.

Through the years, Flo Fab has acquired several companies and service entities including : AQUA-PROFAB (ASME Tanks manufacturer), MÉNARD, LÉONARD ÉLECTRIQUE, PMA. , Furthermore Flo Fab purchased equipment, fabrication designs and patterns from IDEALCO, a manufacturer of shell and tube type heat exchangers.

The after sales services, sales, engineering, R&D, production, quality control, accounting and administration departments of all the above companies share the same location.

In December 2014, Marc Gauvreau, son of the founder, acquired all shares of The company. Flo Fab and is constantly investing in new state of the art innovations new product like the XRI series and Prefab Skid for Hydronic Heating & cooling system, pumping systems. This has allowed Flo Fab to retain competent and experienced staff of professionals with varied and specialized abilities that constantly work on improving our existing products and add new engineered solutions that exceeding customer's expectations .

Flo Fab has grown quite rapidly and now proudly offers of a wide range of products available directly from one manufacturer. This includes pumps & pump packages, tanks, heat exchangers & hydronic accessories. This allows each project stakeholders to enjoy economical savings, peace of mind, best value for their investment and optimized total cost of ownership.



• Applications

FLO FAB S-FOM, D-FOM or Q-FOM Pumping Sets offer several advantages over jobsite assembly of components. Most important is the sole responsibility of the manufacturer for providing predetermined results. One organization selects and coordinates components, fabricates the steel baseplate, the pipe fittings and installs the electrical control panel.

Duplex models are normally-stocked to cover most applications. Other models can be manufactured to meet the requirements for a specific application. A shop drawing and a wiring diagram, both incorporating a list of components, are prepared for approval prior to fabrication. The electrical control system includes one magnetic starter for each pump, indicating lights, a control transformer and a system control pressure switch (see EP panel for complete details). When pump operation is intermittent a control is frequently used to alternate the pumps (on duplex units only) and automatically turn on the back-up pump in case of malfunction.

Models **CYS** are industrial pumps. These pumps have become the industry standard in fuel oil transfer units. Models **CYS** pumps feature a new open-core design that provides improved performance at higher speeds and pressures. The rotor heads are hydraulically-balanced to provide minimum end clearance, assuring instant priming and instant capacity over a wide viscosity and pressure range. The pump is provided with a new improved mechanical face-type seal and Teflon impregnated outboard designed for direct drive. They are capable of handling inlet pressures as high as 200 PSI at standard 1750 RPM motor speeds. As shown in the tables herein, pumps are provided in five sizes. Each pump is provided with an internal relief valve. FLO FAB duplex fuel oil transfer units are ideal in fuel oil transfer systems and generators.

• Features

- 1.** For each fuel oil transfer system, you should have a FLO FAB Series «**FOM**» unit. This system is used to automatically maintain the fuel oil level in a secondary tank.
- 2.** Each unit has the following items:
 - Low-level float and internal pump relief valve
 - A separate external relief valve to return the fuel oil to the main tank (piped by others)
- 3.** Systems have stainless steel rotary vane type pump(s) with electric closed coupled motor(s) :
 - Control panel Nema 1 with piston type pressure switch(es)
 - 3 position selector (H.O.A.)
 - Low-level indicator light
 - High-level shut-off float (by others)
 - Dry contact for remote low level alarm signal (5 amps) (see EP panel for complete details)
 - Type "Y" strainer(s) (one for each pump)
 - Duplex basket strainer
 - Isolating ball valve(s)
 - Pump discharge check valve(s)
 - Liquid filled pressure gauge(s)
 - Factory-assembled, wired and tested prior to shipping

• Selection Charts

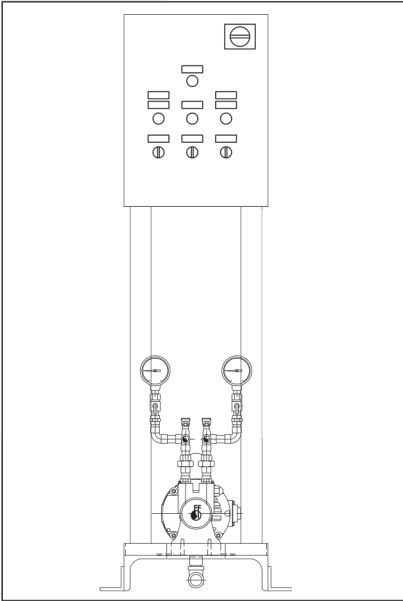
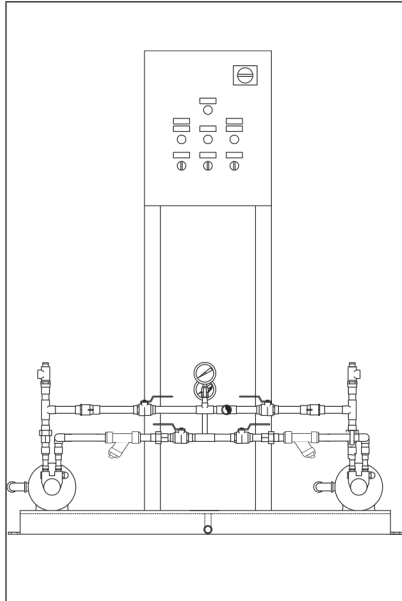
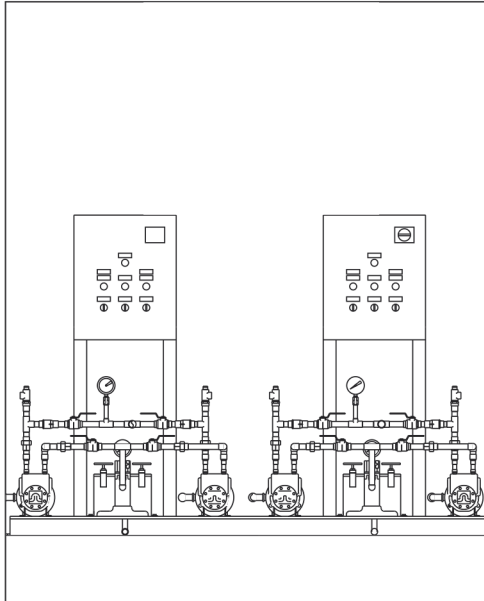
		
<p style="text-align: center;">Series Pump Model</p> <p>Simplex: S - FOM - CYS16 - _____ Example: S - FOM - CYS16 - 170</p>	<p style="text-align: center;">Series Pump Model</p> <p>Duplex: DY - FOM - CYS16 - _____ Example: DY - FOM - CYS16 - 170</p>	<p style="text-align: center;">Series Pump Model</p> <p>Quadruplex: Q - FOM - CYS16 - _____ Example: Q- FOM - CYS16 - 170</p>

• Features

- Simplex, Duplex or Quadruplex Units
- Self-feed transfer unit (transfers fuel oil from main tank to the secondary tank)
- Ability to fill system directly from an external supply

• Components

- | | |
|---|--|
| 1. Pump(s) Closed-coupled rotary vane | 8. Duplex Basket Strainer |
| 2. Motor(s) | 9. Liquid filled Pressure Gauge(s) |
| 3. Simplex, Duplex and Quadruplex Control Panel (see EP panel for proper selection) | 10. Ball Valve(s) |
| 4. System Pressure Switch(es) | 11. Check Valve(s) |
| 5. Pump internal Relief Valve(s) | 12. Copper Piping |
| 6. External Pressure Relief Valve(s) | 13. Steel base-plate for pump(s) and motor(s) |
| 7. Type "Y" Strainer(s) | 14. Electrical connection between panel and motor(s) |

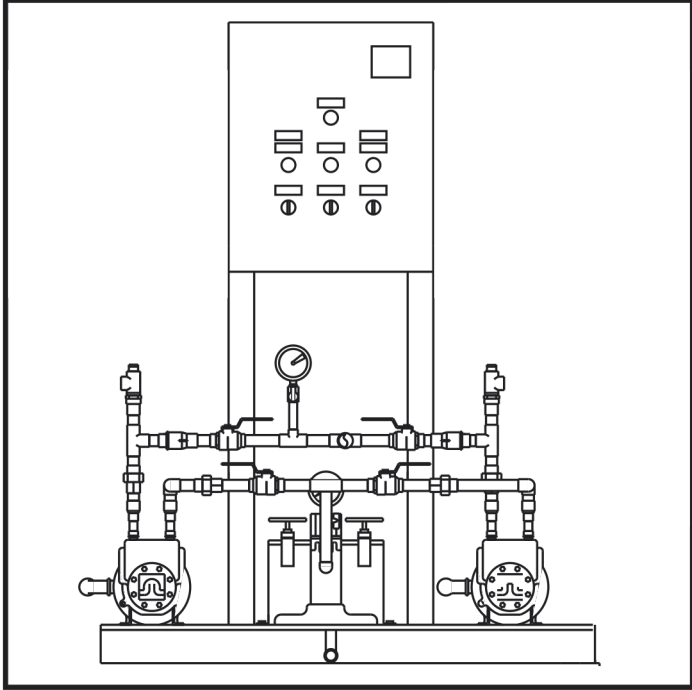
Series Pump Model
<p>Duplex: DP - FOM - CYS16 - _____ Example: DP - FOM - CYS16 - 170</p>

<i>Duplex model shown</i>



Fuel Oil Transfer System

DESCRIPTION

Rotary vane positive displacement pumps run quietly and require no maintenance, for clean fluids at low flow and high pressure. Pumps are designed for pumping moderately aggressive liquids. maintenance The 304 Stainless Steel pump is superior for non-abrasive liquids that are compatible with or pump component materials. Maximum operating temperature is 180 °F.

APPLICATIONS

- Carbonated water for beverage dispensers
- Ultra-filtration
- Deionized water
- Reverse-osmosis systems
- Espresso coffee machines
- Lubrication spraying
- * Light fuel oil
- Insecticide spraying
- Dispensing soap
- Glycol Feed
- Distilled water
- Fire resistant fluids
- * Hydraulic oil
- Steam cleaning machines with clean water
- Cooling circulation
- Pressure booster
- Atomizing misting humidification systems
- Laboratory pumps
- Pilot plants
- Boiler feeds
- Water purification
- Jockey fire pumps and many more applications...

CONSTRUCTION

- Two piece 304 Stainless Steel body
- Built-in bypass relief valve
- Carbon graphite pump chamber and vanes
- Available with or without built-in cleanable strainer
- 71 Mesh Filter
- 304 Stainless Steel
- Hub dimensions for special FLO FAB pump motors
- Clamp included 304 Stainless Steel body
- Carbon graphite pump chamber
- 304 Stainless Steel rotor and shaft
- Carbon graphite vanes
- Carbon rotating seal
- Ceramic stationary seal with Buna N bellows
- Stainless Steel spring

OPERATION

This unit is used to automatically transfer fuel oil from a main tank to a secondary tank. The level float has an adjustable level range for various level requirements. Should the pressure increase to above the setting of the adjustable set range, the relief valve will open allowing the excess pressure/fluid to return to the main tank. When the level float has reached its set point, the pump is turned off. The pump can also operate continuously if the selector switch is in the "manual position A low-level float is provided in the tank. Should the level of fuel oil become dangerously low, it will disable the pump to prevent it from operating without fluid, and send an alarm signal.

Voltage: _____

GALLONS PER HOUR AT PRESSURE IN POUNDS PER SQUARE INCH GAUGE (PSI)*											
Models	In / Out	20 PSI	40 PSI	60 PSI	80 PSI	100 PSI	120 PSI	140 PSI	160 PSI	180 PSI	200 PSI
Stainless Steel											
CYS16-170	3/8"	49 - 1/4hp	48 - 1/4hp	47 - 1/4hp	46 - 1/4hp	45 - 1/4hp	43 - 1/4hp	42 - 1/4hp	41 - 1/4hp	40 - 1/4hp	39 - 1/4hp
CYS16-295	3/8"	111 - 1/4hp	110 - 1/4hp	109 - 1/4hp	108 - 1/4hp	107 - 1/3hp	105 - 1/3hp	104 - 1/3hp	103 - 1/3hp	102 - 1/2hp	101 - 1/2hp
CYS16-377	3/8"	144 - 1/4hp	143 - 1/4hp	142 - 1/4hp	141 - 1/3hp	140 - 1/3hp	138 - 1/3hp	137 - 1/2hp	136 - 1/2hp	135 - 1/2hp	134 - 1/2hp
CYS16-560	1/2"	201 - 1/4hp	200 - 1/3hp	198 - 1/3hp	197 - 1/3hp	196 - 1/3hp	195 - 1/2hp	194 - 1/2hp	193 - 1/2hp	192 - 1/2hp	190 - 1/2hp
CYS16-1026	1/2"	327 - 1/3hp	326 - 1/3hp	324 - 1/2hp	323 - 1/2hp	322 - 1/2hp	321 - 3/4hp	320 - 3/4hp	318 - 3/4hp	317 - 3/4hp	316 - 3/4hp

* Performance based on water at 68°F, no inlet pressure, motor speed of 1725 RPM. Flows will change in direct proportion to new speed vs. old speed



● Pump Standard Specifications

BODY Stainless Steel
CAPACITY 49 to 316 gallons/hour
NOMINAL SPEED 1725 RPM
MAXIMUM DISCHARGE PRESSURE 200 PSI
ROTATION Clockwise
NET WEIGHT 2.75 lbs
SELF PRIMING (Fuel oil) max. 6 feet

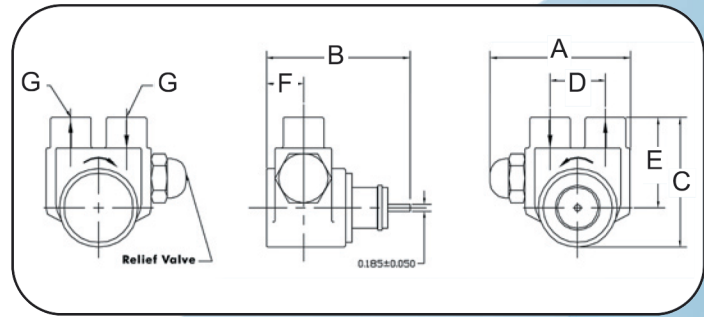

● Dimensions

Model	A		B		C		D		E		F		G (NPT)	
	in	mm	in	mm	in	mm	in	mm	in	mm	in	mm	in	mm
CYS16-170	3 7/16	91	3 7/8	99	3 1/2	95	1 1/2	40	2 7/16	61	1	25	3/8	9
CYS16-295	3 7/16	91	3 7/8	99	3 1/2	95	1 1/2	40	2 7/16	61	1	25	3/8	9
CYS16-377	3 7/16	91	3 7/8	99	3 1/2	95	1 1/2	40	2 7/16	61	1	25	3/8	9
CYS16-560	4 3/16	105	4 3/8	109	3 7/8	99	1 7/8	47	2 1/2	65	1 1/4	32	1/2	15
CYS16-1026	4 3/16	105	4 3/8	109	3 7/8	99	1 7/8	47	2 1/2	65	1 1/4	32	1/2	15

● Typical Specifications

The contractor shall furnish and install a Simplex, Duplex or Quadruplex fuel oil transfer system models **S-FOM**, **D-FOM** or **Q-FOM** as designed and manufactured by FLO FAB. The system shall be capable of automatically transferring fuel oil from a main tank to a secondary tank. Maximum discharge pressure should not exceed 200 PSI and maximum operating temperature is 180°F.

The system shall be a factory-manufactured one-piece assembly and shall contain: pump(s), check valve(s), ball valve(s), type "Y" strainers or Duplex basket strainer, independent mounted relief valve(s), control panel(s), a low-level switch and all necessary electrical controls and accessories for a completely automatic operation.

PUMP

The rotary vane positive displacement pump(s) series **FOM** shall be constructed of 304 stainless steel, and will have a built-in By Pass relief valve as manufactured by FLO FAB. The pump(s) shall have carbon graphite vanes, carbon rotating seal, ceramic stationary seal with Buna N bellows and stainless steel spring. The electric close-coupled motor(s) shall be open drip-proof type motor, standard NEMA construction. Single-phase fractional H.P. motor to include built-in thermal overload protection and stainless steel shaft. Motor bearings shall be sealed and factory greased for extra long trouble-free operation.

RELIEF VALVE

Adjustable pressure relief valve (with discharge piped to tank by others)

BALL VALVES

All ball valves shall be of bronze construction series LBV as manufactured by FLO FAB and shall be sized to minimize the pressure drop through the system.

SILENT CHECK VALVE

On each pump discharge a silent bronze check valve series STB FLO FAB shall be installed.

PRESSURE GAUGE

Liquid-filled FLO FAB pressure gauges shall be installed on the suction and discharge of the pump(s).

STRAINERS

Duplex basket strainer FLO FAB model DBS with a stainless steel basket or type "Y" strainers FLO FAB model LCTY (will be installed at pump(s) inlet)

CONTROLLER(S)

NEMA 1 Simplex or duplex control panel(s) shall include: manual transfer, HOA, pilot lights, low-level shut-off float. The system level float shall have an adjustable level range in order to increase and decrease the level according to the tank requirements. When the level float has reached its set point, the pump is turned off. The low-level float installed in the tank shall disable the pump(s) and send an alarm signal should the fuel oil level become dangerously low.



G & H SERIES HELICAL

FEATURES

- Helical Gears for smooth, quiet running.
- Self Priming due to close manufacturing tolerances.
- Suction lift of up to 20 feet
- Can be close coupled or base mounted with pump-motor unit.
- Pump housings are of close grain cast iron.
- 3 Section doweled design insures alignment, efficiency and ease of field service.
- Shafts are of ground and polished steel.
- Full face thrust bearings are available in bronze, carbon, and cast iron.
- Mechanical seals are of Buna, Viton, and Teflon.



EASY MAINTENANCE

The 3-Section design of the Albany Pump combined with the unique slide fit of the bearings makes disassembly of the pump and replacement of individual components easy and simple.

By-pass model pumps (integral relief valve) can be converted to plain pumps (no by-pass) by interchanging pump covers (and vice-versa). The various bearings available can be interchanged in the field to suit the application requirement.

PERFORMANCE

G SERIES (0-250 PSI)

✓	MODEL	MAX. CAPACITY @ 1750 RPM	M3/H	MAX. DIFF. PRESS.	MAX. HP REQ'D
	FF03G	3.4 US/gpm	0,77 M3/H	250 psi	3/4 hp
	FF05G	5.3 US/gpm	1,20 M3/H	250 psi	1.5 hp
	FF10G	10.5 US/gpm	2,38 M3/H	250 psi	2.5 hp
	FF18G	18.1 US/gpm	4,11 M3/H	250 psi	5 hp
	FF25G	26 US/gpm	5,90 M3/H	250 psi	5 hp
	FF35G	35 US/gpm	7,95 M3/H	250 psi	7.5 hp

H SERIES (0-500 PSI)

✓	MODEL	MAX. CAPACITY @ 1750 RPM	M3/H	MAX. DIFF. PRESS.	MAX. HP REQ'D
	FF03H	3.4 US/gpm	0,77 M3/H	500 psi	1.5 hp
	FF05H	5.6 US/gpm	1,27 M3/H	500 psi	2.5 hp
	FF10H	11.4 US/gpm	2,59 M3/H	500 psi	5 hp
	FF18H	18 US/gpm	4,09 M3/H	500 psi	7.5 hp
	FF25H	25 US/gpm	5,68 M3/H	500 psi	10hp
	FF35H	37 US/gpm	8,40 M3/H	500 psi	15 hp



FUEL OIL TRANSFER SYSTEMS

G SERIES HELICAL

03G SERIES 0-3 GPM/0-250 PSI 1/2" NPT

GENERAL DUTY G-SERIES GEAR PUMPS

The G series General Gear Pumps are a close tolerance, medium flow, high pressure positive displacement pump. A standard in the industry since 1906.

APPLICATIONS

- Oil Transfer Pump
- Liquid Transfer/Circulation
- Small Booster Jockey Pump
- Spray Nozzles/Misting
- Hydraulic/Hydrostatic

FLOW: 0-3 GPM | 0-0.18 L/s | 0-0.68 m³/hr

PRESSURE: 0-250 PSI | 10.5 Bar | 0-346 Ft.

FEATURES

- Precision Spur Style Gears
- Self Priming due to close manufacturing tolerances
- Suction lift of up to 25 feet
- Pump housings are of Cast Iron
- Pump shafts are of stainless steel
- Mechanical seals of Buna or Viton
- Carbon graphite shaft bearings
- Bearings never need lubrication
- Easy maintenance and service

SPECIFICATIONS

PORTS	1/2" NPT / 12.5 mm
CAPACITY	3.0 USGPM / 0.18 L/s (Max.)
PRESSURE	250 PSI / 10.5 Bar (Max.)
INLET PRESSURE	50 PSI / 3.5 Bar (Max.)
TEMPERATURE	225°F (100°C) (Buna Seal)

ROTATION

Standard rotation has the pump discharge on the right (facing the pump end). Standard Motors are uni-directional, so to change the rotation on the pumps simply loosen the bolt that holds the pump-end to the motor, and rotate the pump 180° so the discharge is on the left.

MAINTENANCE

To ensure a long life to this pump a strainer is always recommended in front of the pump inlet.

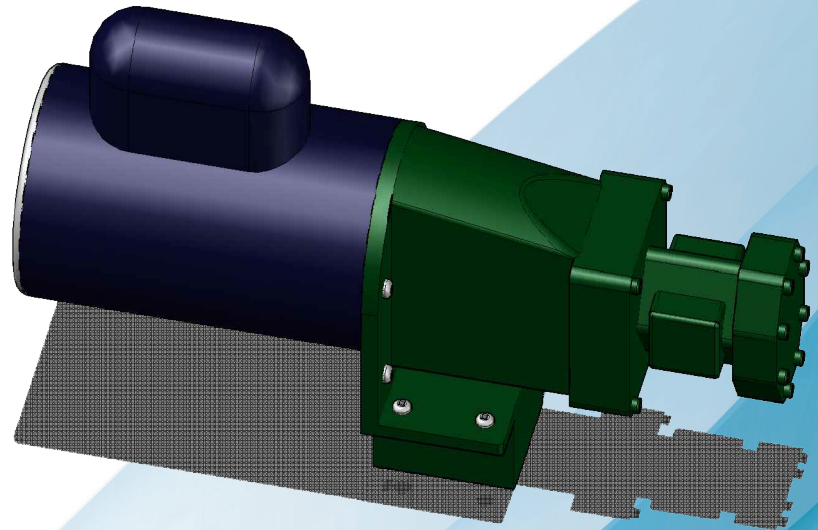

PERFORMANCE

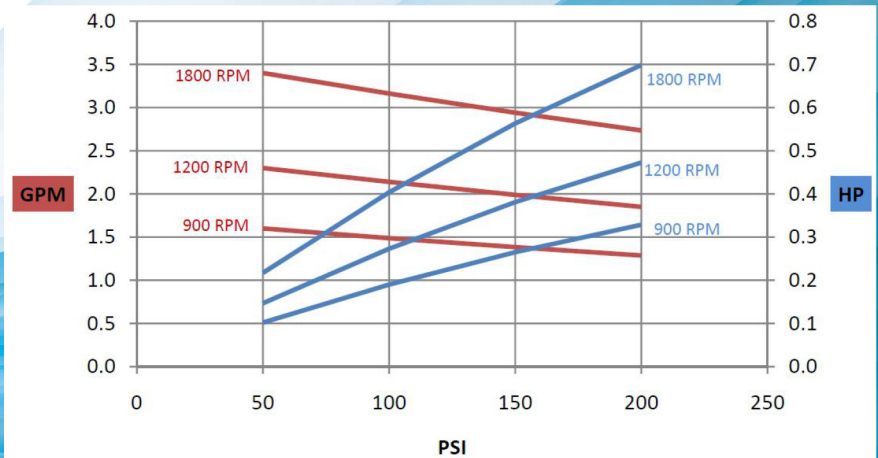

DIMENSIONS

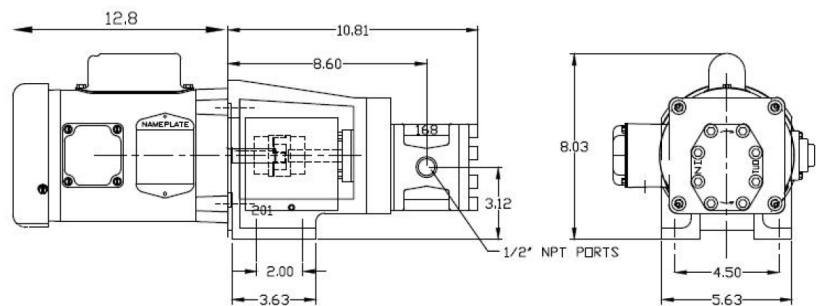

Note: Motor dimensions may vary.



FUEL OIL TRANSFER SYSTEMS

G SERIES HELICAL

05G SERIES 0-5 GPM/0-250 PSI 3/4" NPT

GENERAL DUTY G-SERIES GEAR PUMPS

The G series General Gear Pumps are a close tolerance, medium flow, high pressure positive displacement pump. A standard in the industry since 1906.

APPLICATIONS

- Oil Transfer Pump
- Liquid Transfer/Circulation
- Small Booster Jockey Pump
- Spray Nozzles/Misting
- Hydraulic/Hydrostatic

FLOW: 0-5 GPM | 0-0.32 L/s | 0-1.14 m³/hr

PRESSURE: 0-250 PSI | 10.5 Bar | 0-346 Ft.

FEATURES

- Precision Spur Style Gears
- Self Priming due to close manufacturing tolerances
- Suction lift of up to 25 feet
- Pump housings are of Cast Iron
- Pump shafts are of stainless steel
- Mechanical seals of Buna or Viton
- Carbon graphite shaft bearings
- Bearings never need lubrication
- Easy maintenance and service

SPECIFICATIONS

PORTS	3/4" NPT / 19.1 mm
CAPACITY	5.0 USGPM / 0.32 L/s (Max.)
PRESSURE	250 PSI / 10.5 Bar (Max.)
INLET PRESSURE	50 PSI / 3.5 Bar (Max.)
TEMPERATURE	225°F (100°C) (Buna Seal)

ROTATION

Standard rotation has the pump discharge on the right (facing the pump end). Standard Motors are uni-directional, so to change the rotation on the pumps simply loosen the bolt that holds the pump-end to the motor, and rotate the pump 180° so the discharge is on the left.

MAINTENANCE

To ensure a long life to this pump a strainer is always recommended in front of the pump inlet.

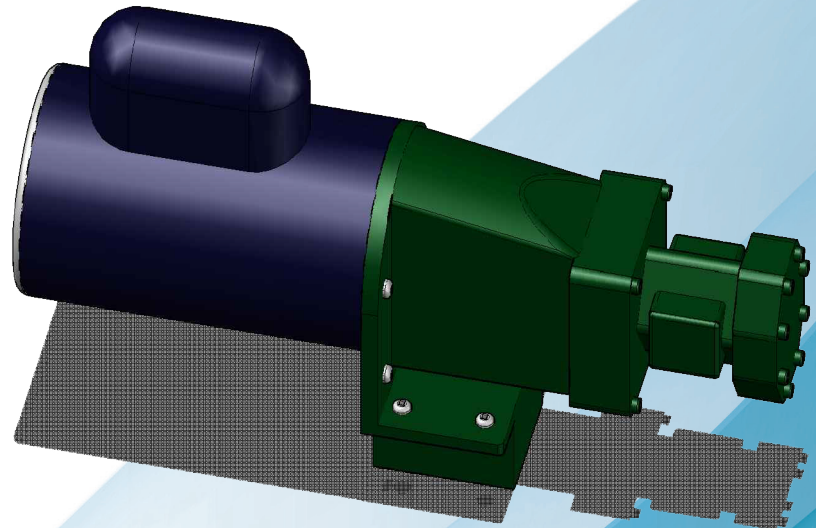

PERFORMANCE

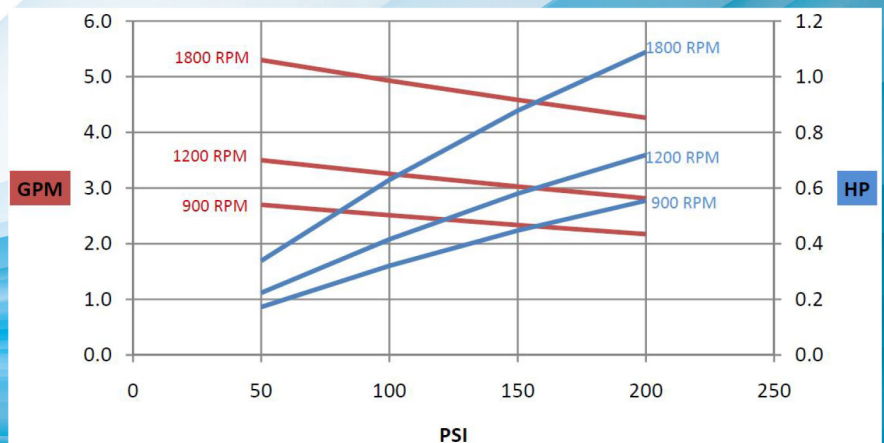

DIMENSIONS

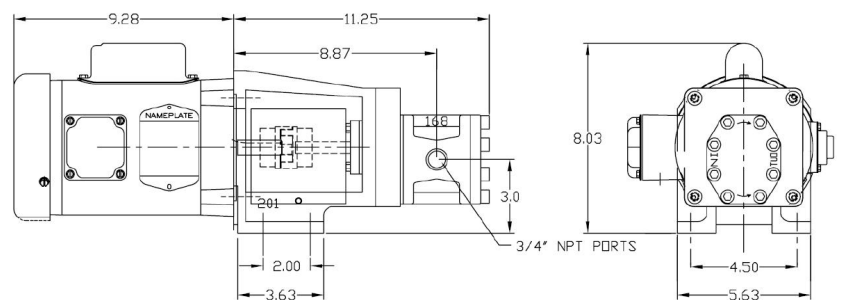

Note: Motor dimensions may vary.



FUEL OIL TRANSFER SYSTEMS

G SERIES HELICAL

10G SERIES 0-10 GPM/0-250 PSI 1" NPT

GENERAL DUTY G-SERIES GEAR PUMPS

The G series General Gear Pumps are a close tolerance, medium flow, high pressure positive displacement pump. A standard in the industry since 1906.

APPLICATIONS

- Oil Transfer Pump
- Liquid Transfer/Circulation
- Small Booster Jockey Pump
- Spray Nozzles/Misting
- Hydraulic/Hydrostatic

FLOW: 0-10 GPM | 0-0.63 L/s | 0-2.27 m³/hr

PRESSURE: 0-250 PSI | 10.5 Bar | 0-346 Ft.

FEATURES

- Precision Spur Style Gears
- Self Priming due to close manufacturing tolerances
- Suction lift of up to 25 feet
- Pump housings are of Cast Iron
- Pump shafts are of stainless steel
- Mechanical seals of Buna or Viton
- Carbon graphite shaft bearings
- Bearings never need lubrication
- Easy maintenance and service

SPECIFICATIONS

PORTS	1" NPT / 25.4 mm
CAPACITY	10.0 USGPM / 0.63 L/s (Max.)
PRESSURE	250 PSI / 10.5 Bar (Max.)
INLET PRESSURE	50 PSI / 3.5 Bar (Max.)
TEMPERATURE	225° F (100°C) (Buna Seal)

ROTATION

Standard rotation has the pump discharge on the right (facing the pump end). Standard Motors are uni-directional, so to change the rotation on the pumps simply loosen the bolt that holds the pump-end to the motor, and rotate the pump 180° so the discharge is on the left.

MAINTENANCE

To ensure a long life to this pump a strainer is always recommended in front of the pump inlet.

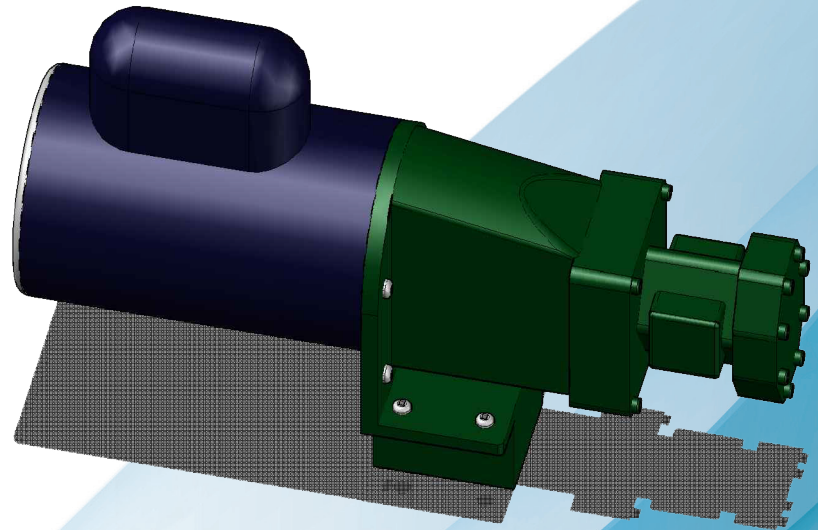

PERFORMANCE

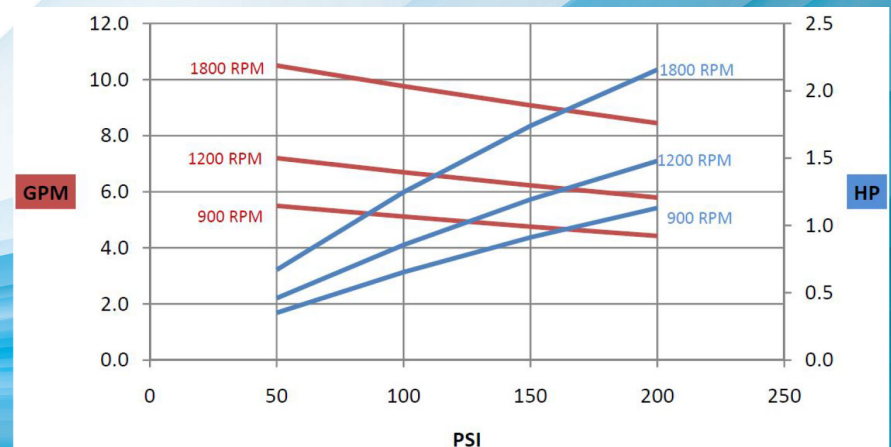

DIMENSIONS

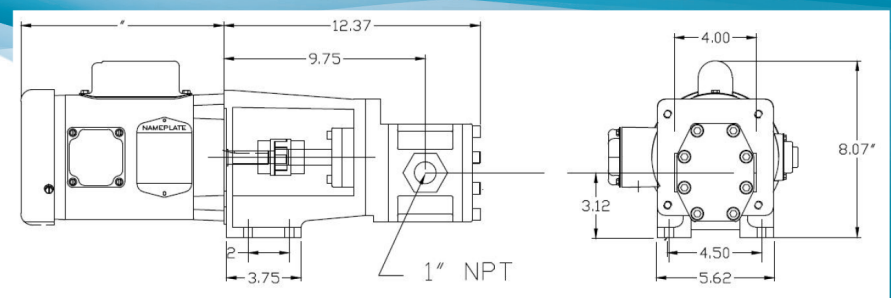

Note: Motor dimensions may vary.



FUEL OIL TRANSFER SYSTEMS

G SERIES HELICAL

18G SERIES 0-18 GPM/0-250 PSI 1-1/4" NPT

GENERAL DUTY G-SERIES GEAR PUMPS

The G series General Gear Pumps are a close tolerance, medium flow, high pressure positive displacement pump. A standard in the industry since 1906.

APPLICATIONS

- Oil Transfer Pump
- Liquid Transfer/Circulation
- Small Booster Jockey Pump
- Spray Nozzles/Misting
- Hydraulic/Hydrostatic

FLOW: 0-18 GPM | 0-1.13 L/s | 0-4.09 m³/hr

PRESSURE: 0-250 PSI | 10.5 Bar | 0-346 Ft.

FEATURES

- Precision Spur Style Gears
- Self Priming due to close manufacturing tolerances
- Suction lift of up to 25 feet
- Pump housings are of Cast Iron
- Pump shafts are of stainless steel
- Mechanical seals of Buna or Viton
- Carbon graphite shaft bearings
- Bearings never need lubrication
- Easy maintenance and service

SPECIFICATIONS

PORTS	1-1/4" NPT / 31.8 mm
CAPACITY	18.0 USGPM / 1.13 L/s (Max.)
PRESSURE	250 PSI / 10.5 Bar (Max.)
INLET PRESSURE	50 PSI / 3.5 Bar (Max.)
TEMPERATURE	225° F (100°C) (Buna Seal)

ROTATION

Standard rotation has the pump discharge on the right (facing the pump end). Standard Motors are uni-directional, so to change the rotation on the pumps simply loosen the bolt that holds the pump-end to the motor, and rotate the pump 180° so the discharge is on the left.

MAINTENANCE

To ensure a long life to this pump a strainer is always recommended in front of the pump inlet.



PERFORMANCE

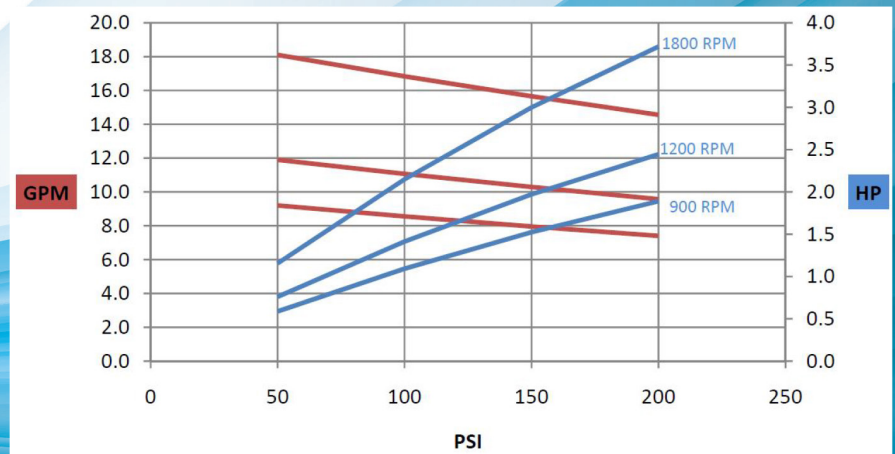

DIMENSIONS

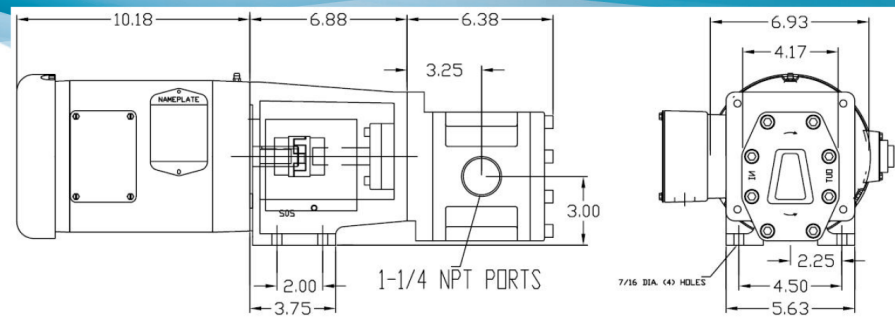

Note: Motor dimensions may vary.



FUEL OIL TRANSFER SYSTEMS

G SERIES HELICAL

25G SERIES 0-25 GPM/0-250 PSI 1-1/2" NPT

GENERAL DUTY G-SERIES GEAR PUMPS

The G series General Gear Pumps are a close tolerance, medium flow, high pressure positive displacement pump. A standard in the industry since 1906.

APPLICATIONS

- Oil Transfer Pump
- Liquid Transfer/Circulation
- Small Booster Jockey Pump
- Spray Nozzles/Misting
- Hydraulic/Hydrostatic

FLOW: 0-25 GPM | 0-1.58 L/s | 0-5.68 m³/hr

PRESSURE: 0-250 PSI | 10.5 Bar | 0-346 Ft.

FEATURES

- Precision Spur Style Gears
- Self Priming due to close manufacturing tolerances
- Suction lift of up to 25 feet
- Pump housings are of Cast Iron
- Pump shafts are of stainless steel
- Mechanical seals of Buna or Viton
- Carbon graphite shaft bearings
- Bearings never need lubrication
- Easy maintenance and service

SPECIFICATIONS

PORTS	1-1/2" NPT / 38.1 mm
CAPACITY	25.0 USGPM / 1.58 L/s (Max.)
PRESSURE	250 PSI / 10.5 Bar (Max.)
INLET PRESSURE	50 PSI / 3.5 Bar (Max.)
TEMPERATURE	225° F (100°C) (Buna Seal)

ROTATION

Standard rotation has the pump discharge on the right (facing the pump end). Standard Motors are uni-directional, so to change the rotation on the pumps simply loosen the bolt that holds the pump-end to the motor, and rotate the pump 180° so the discharge is on the left.

MAINTENANCE

To ensure a long life to this pump a strainer is always recommended in front of the pump inlet.

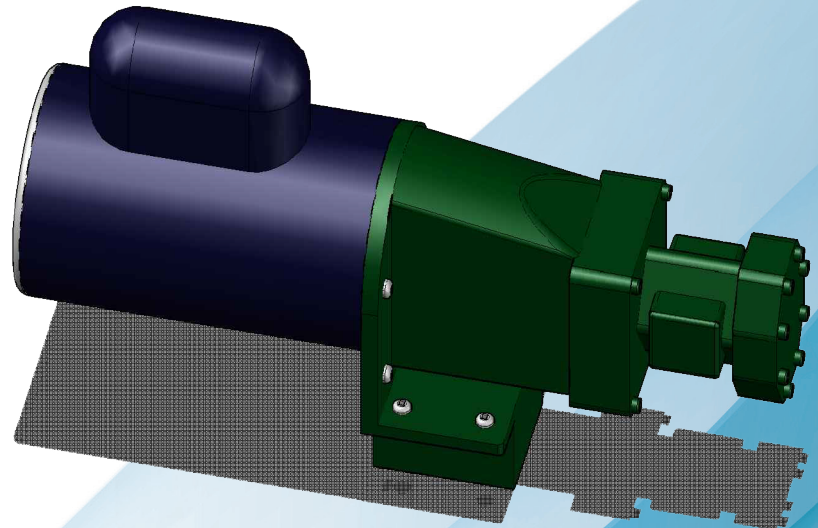

PERFORMANCE

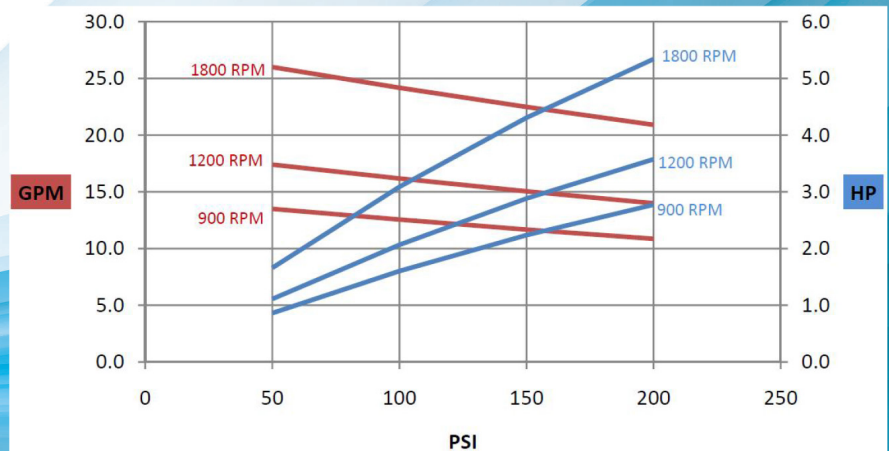

DIMENSIONS

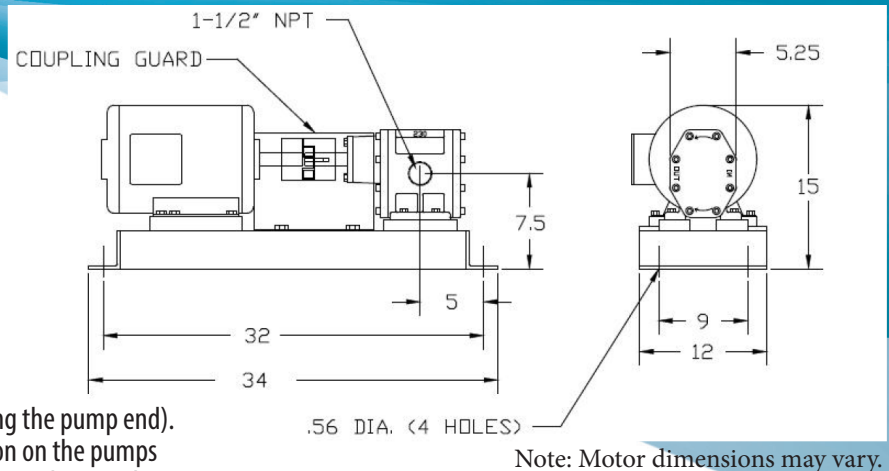



FUEL OIL TRANSFER SYSTEMS

G SERIES HELICAL

35G SERIES 0-35 GPM/0-250 PSI 1-1/2" NPT

GENERAL DUTY G-SERIES GEAR PUMPS

The G series General Gear Pumps are a close tolerance, medium flow, high pressure positive displacement pump. A standard in the industry since 1906.

APPLICATIONS

- Oil Transfer Pump
- Liquid Transfer/Circulation
- Small Booster Jockey Pump
- Spray Nozzles/Misting
- Hydraulic/Hydrostatic

FLOW: 0-35 GPM | 0-2.21 L/s | 0-7.95 m³/hr

PRESSURE: 0-250 PSI | 10.5 Bar | 0-346 Ft.

FEATURES

- Precision Spur Style Gears
- Self Priming due to close manufacturing tolerances
- Suction lift of up to 25 feet
- Pump housings are of Cast Iron
- Pump shafts are of stainless steel
- Mechanical seals of Buna or Viton
- Carbon graphite shaft bearings
- Bearings never need lubrication
- Easy maintenance and service

SPECIFICATIONS

PORTS	1-1/2" NPT / 38.1 mm
CAPACITY	35.0 USGPM / 2.21 L/s (Max.)
PRESSURE	250 PSI / 10.5 Bar (Max.)
INLET PRESSURE	50 PSI / 3.5 Bar (Max.)
TEMPERATURE	225° F (100°C) (Buna Seal)

ROTATION

Standard rotation has the pump discharge on the right (facing the pump end). Standard Motors are uni-directional, so to change the rotation on the pumps simply loosen the bolt that holds the pump-end to the motor, and rotate the pump 180° so the discharge is on the left.

MAINTENANCE

To ensure a long life to this pump a strainer is always recommended in front of the pump inlet.

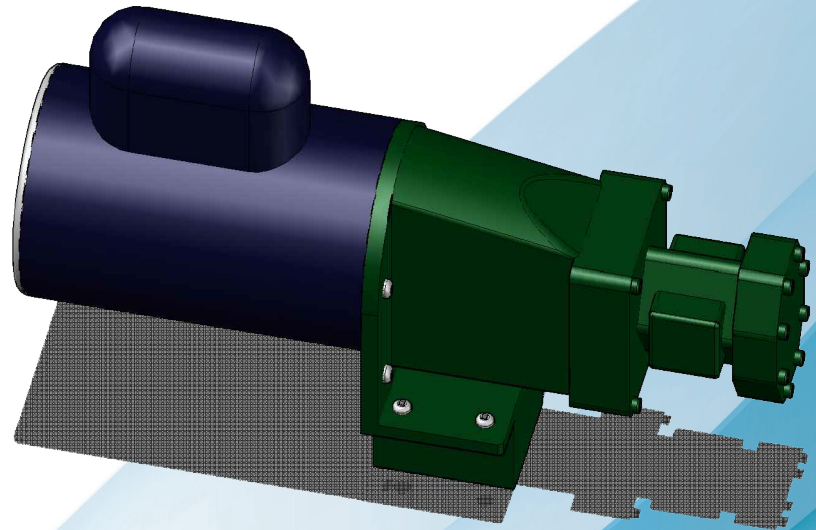

PERFORMANCE

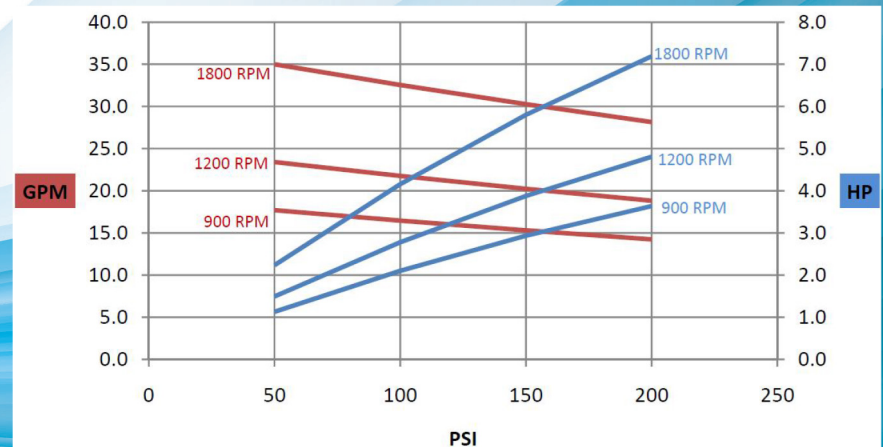

DIMENSIONS

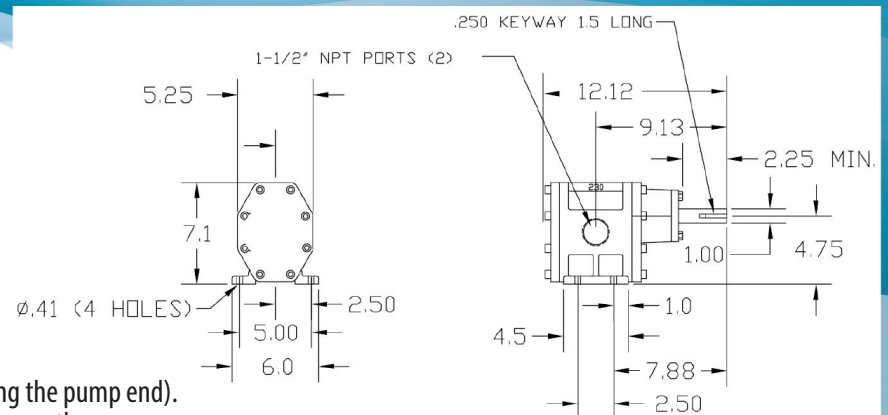

Note: Motor dimensions may vary.

G & H SERIES HELICAL

DIMENSIONS

Dimensions - G & H Series Helical Rotary Gear Pumps

03 Series

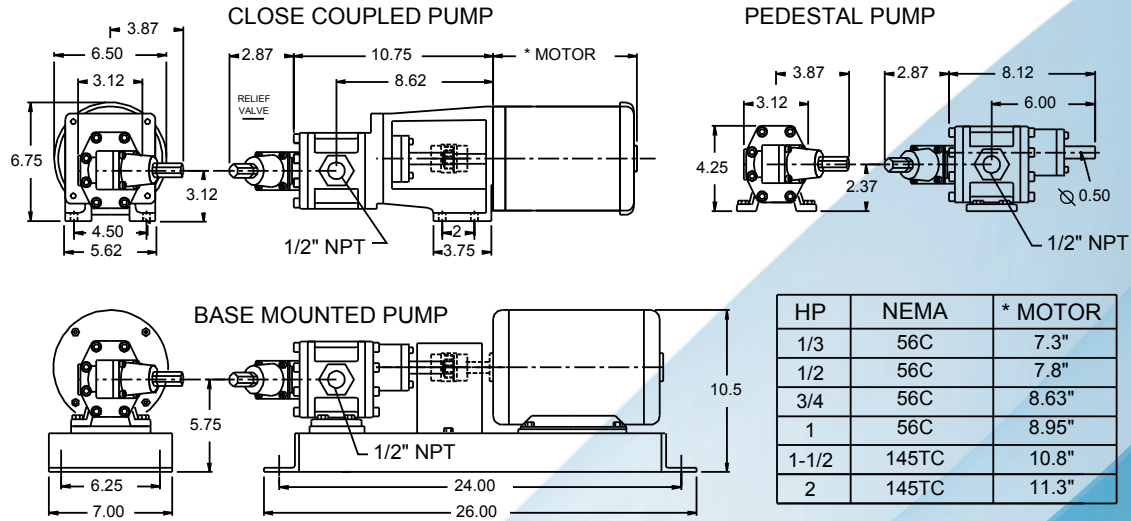

05 Series

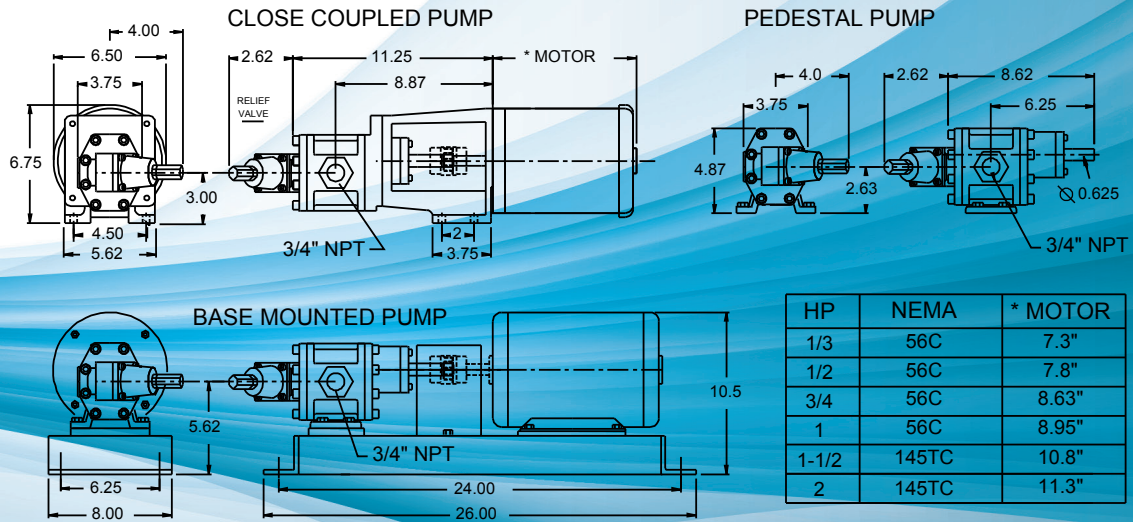

10 Series

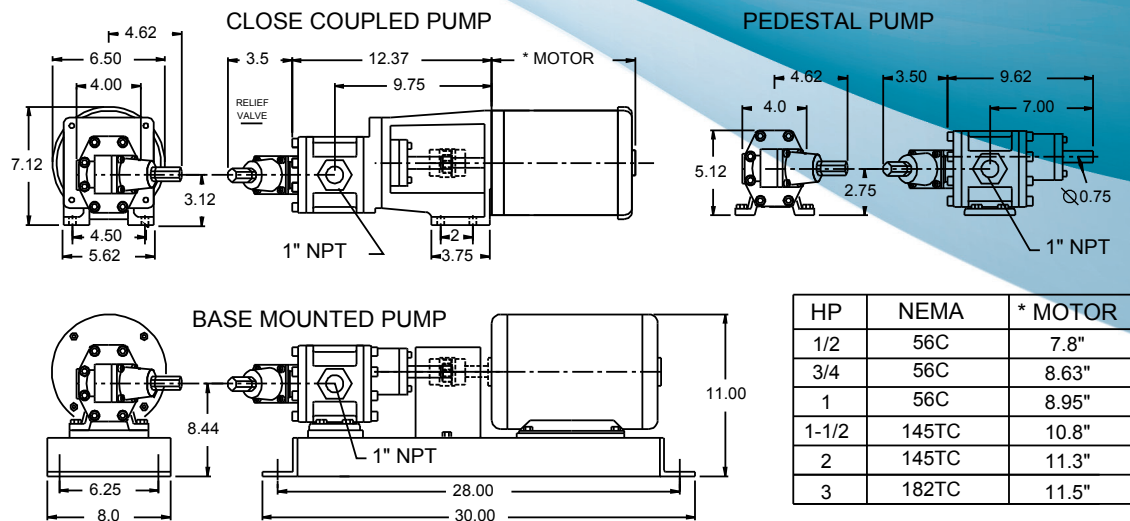

G & H SERIES HELICAL

DIMENSIONS

Dimensions - G & H Series Helical Rotary Gear Pumps

CLOSE COUPLED PUMP

PEDESTAL PUMP

BASE MOUNTED PUMP

HP	NEMA	* MOTOR
1/2	56C	7.8"
3/4	56C	8.63"
1	56C	8.95"
1-1/2	145TC	10.8"
2	145TC	11.3"
3	182TC	11.5"

18 Series

PEDESTAL PUMP

BASE MOUNTED PUMP

25 Series

PEDESTAL PUMP

BASE MOUNTED PUMP

35 Series



FUEL OIL TRANSFER SYSTEMS

H SERIES HELICAL CURVES

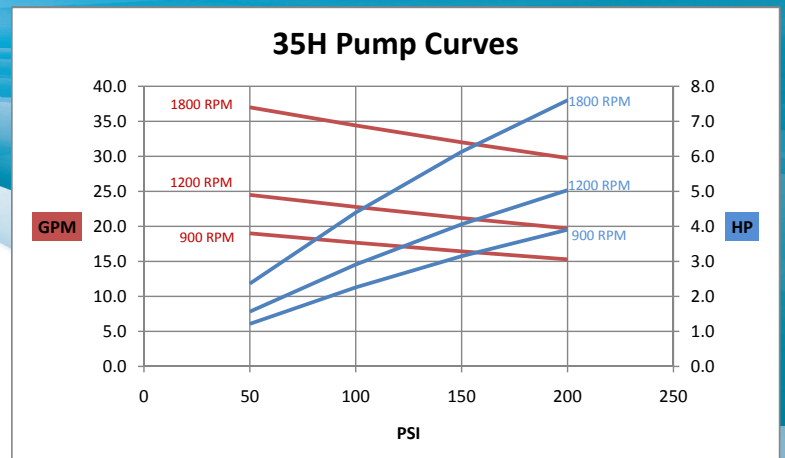
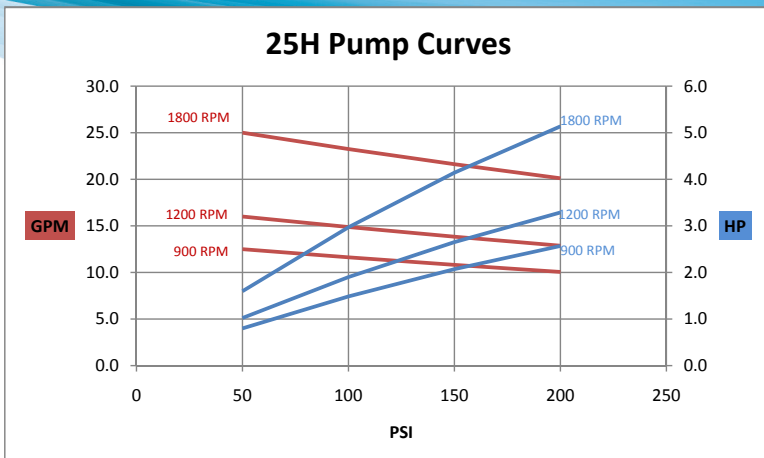
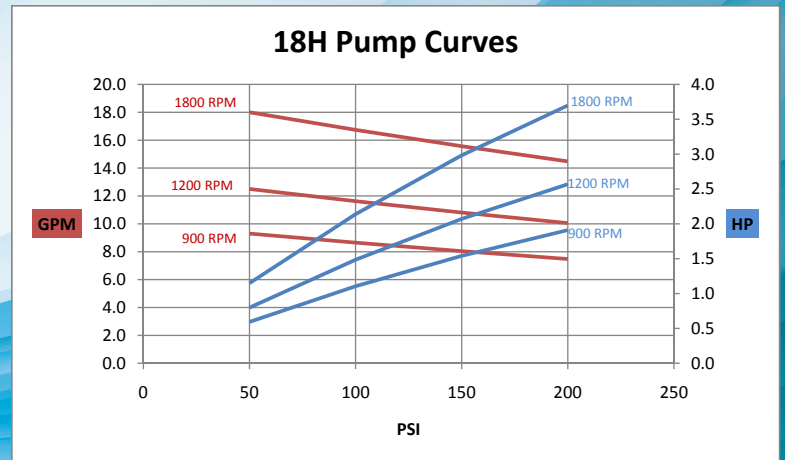
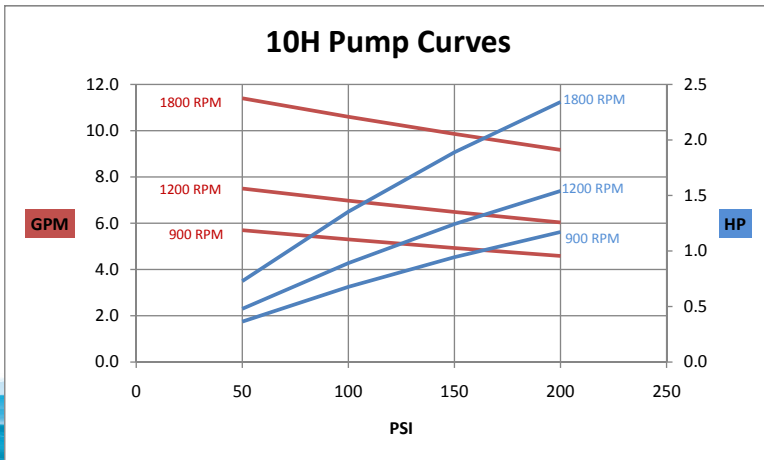
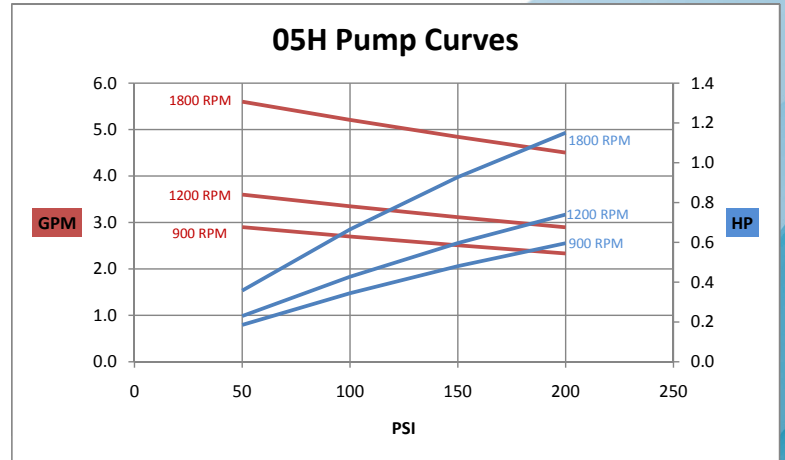
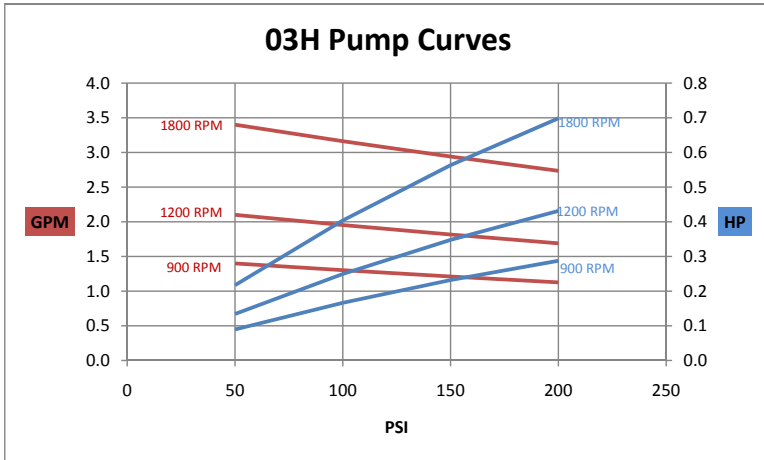

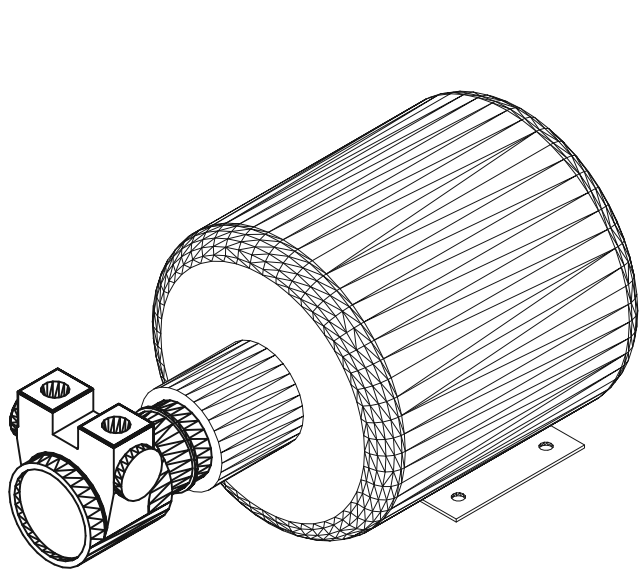

FRONT VIEW

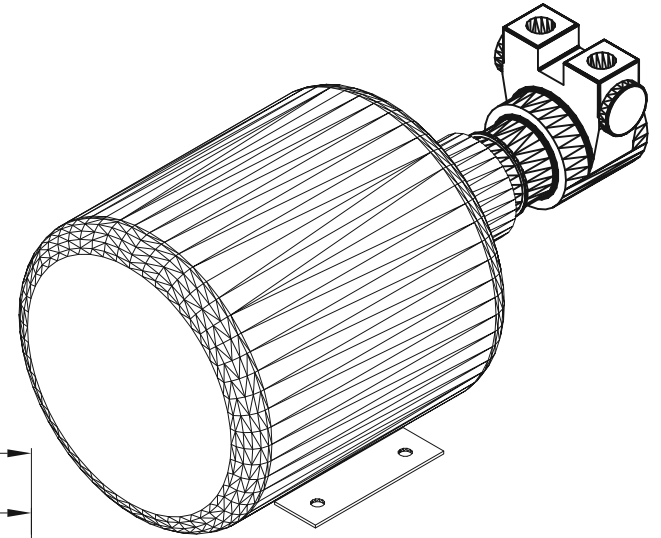

BACK VIEW

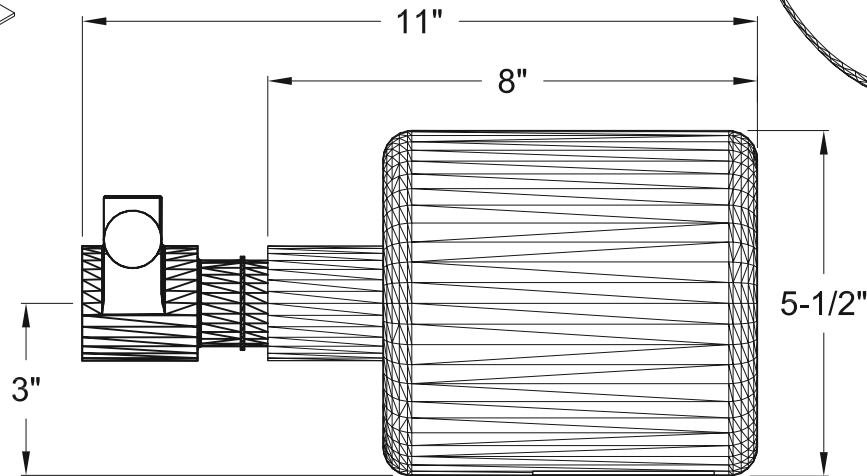

SIDE VIEW

STANDARD	<input type="checkbox"/>	SY-FOM-CYS16-170
	<input type="checkbox"/>	SY-FOM-CYS16-295
	<input type="checkbox"/>	SY-FOM-CYS16-377
	<input type="checkbox"/>	SY-FOM-CYS16-560
	<input type="checkbox"/>	SY-FOM-CYS16-1026

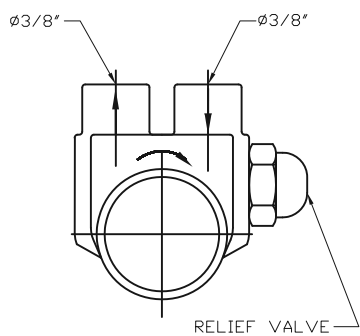

RELIEF VALVE

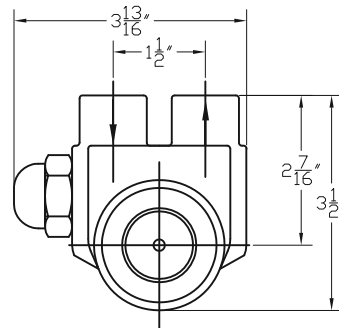
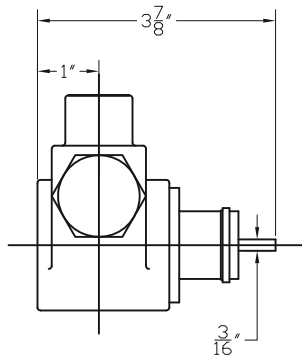

DETAILS

DESSIN TYPIQUE, LES DIMENSIONS FINALES ET LE DESIGN PEUVENT VARIER.
TYPICAL DRAWING, FINALE DIMENSIONS AND DESIGN MAY VARY

TITLE / TITRE
**FLO FAB PUMP
SERIES CYS16**

	PROJECT/PROJET	
	CUSTOMER / CLIENT	
860 BOULEVARD INDUSTRIEL BOIS-DES-FILION, QC J6Z 4V7, (450) 621-2995	PART LIST N° / LISTE DE MATERIEL N°	DATE / DATE
	DRAWN BY / DESSINATEUR M. LYMBURNER	SCALE / ECHELLE N / A
		REV 0

REVISION BLOCK				
ZONE	REV	DESCRIPTION	DATE	APPROVED

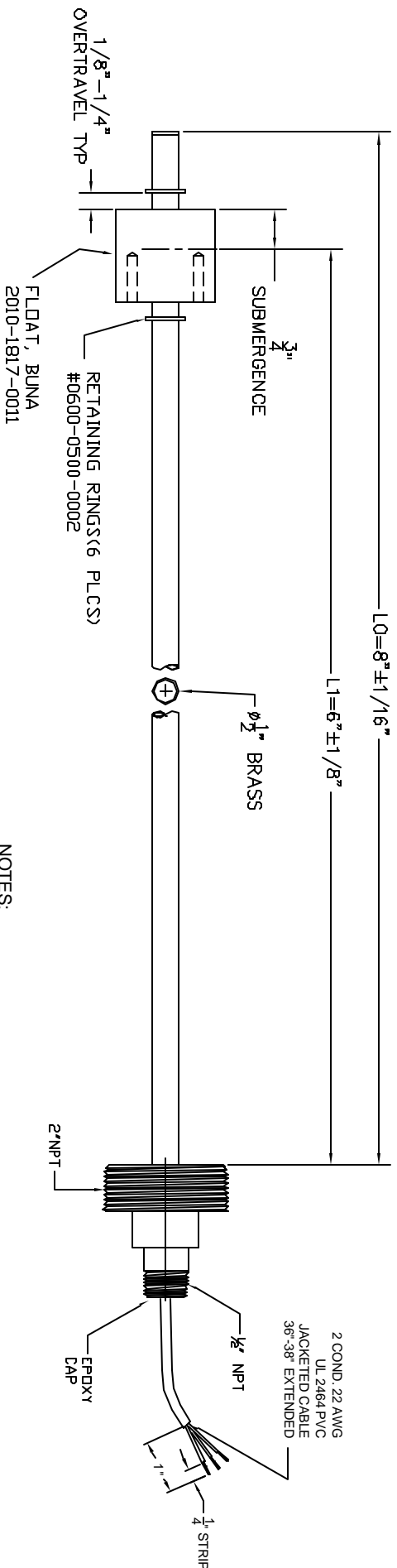

NOTES:

1. ELECTRICAL RATING: 100 WATT MAX; 240 VOLTS MAX; 1.0 AMP MAX.
2. TEMPERATURE LIMIT: 180°F MAX.
3. PRESSURE LIMIT: 150 PSIG.
4. WETTED MATERIALS: STEM ASSY BRASS
FLOAT ASSY BUNA
GRIPRING BE-CU
5. MINIMUM MEDIA SPECIFIC GRAVITY: .57 S.G.

WIRING SCHEMATIC

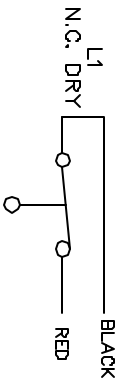

ITEM QTY	PART NUMBER	DESCRIPTION	SPEC
01			
UNLESS OTHERWISE SPECIFIED			
DIMENSIONS ARE IN INCHES			
.X±0.1 .XX±0.01 .XXX±0.005			
FRACTIONS ±1/8 ANGLES ±30°			
MACHINED SURFACES: $\sqrt{63}$ RMS			
MAT'L: XXXXX		NEXT ASS'Y	
SIZE B		SCALE NONE	DRN: MD 2/7/05
F3DM NO.		DWG NO.	SHEET 1 OF 1
REV 00			

1 2 3 4

REVISION BLOCK				
ZONE	REV	DESCRIPTION	DATE	APPROVED

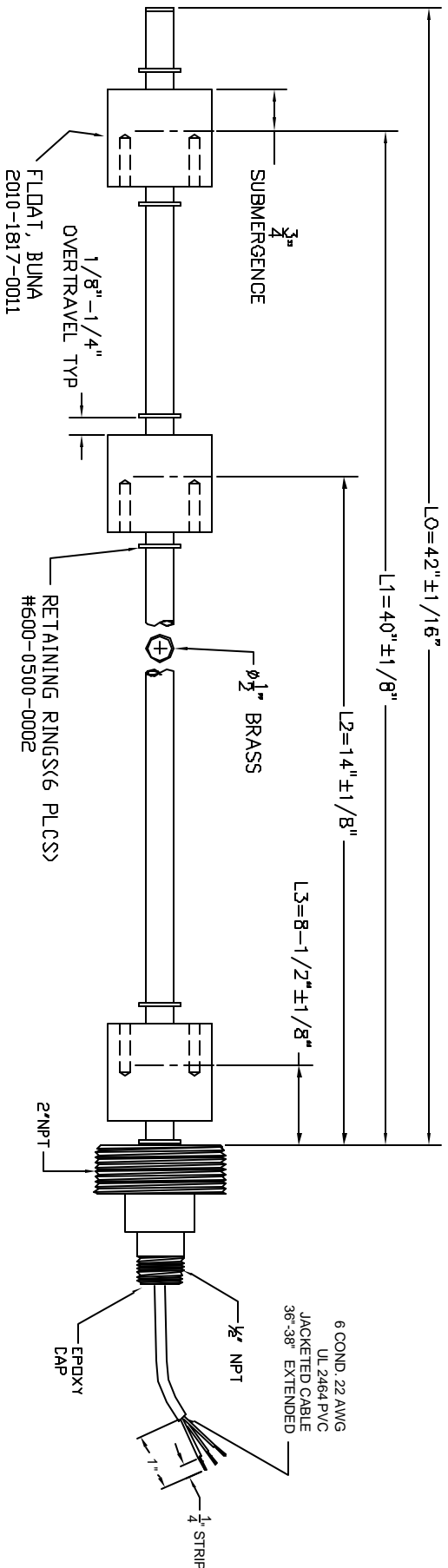

WIRING SCHEMATIC

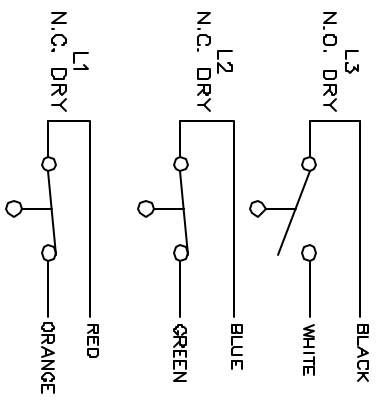

- NOTES:**
1. ELECTRICAL RATING: 100 WATT MAX; 240 VOLTS MAX; 1.0 AMP MAX.
 2. TEMPERATURE LIMIT: 180°F MAX.
 3. PRESSURE LIMIT: 150 PSIG.
 4. WETTED MATERIALS: STEM ASSY BRASS FLOAT ASSY BUNA GRIPRING BE-CU
 5. MINIMUM MEDIA SPECIFIC GRAVITY: .57 S.G.

ITEM QTY	PART NUMBER	DESCRIPTION	SPEC
01		LEVEL SWITCH, L500, BRSS/BUNA, 3 LVL, 2" NPT	

UNLESS OTHERWISE SPECIFIED
 DIMENSIONS ARE IN INCHES
 .X±0.1 .XX±0.01 .XXX±0.005
 FRACTIONS ±1/8 ANGLES ±30°
 MACHINED SURFACES: 63 √ RMS
 MAT'L: XXXXX

SCALE	NONE	DRN	MD	E/7/05	SECT	1	DF	1
REV	00							

1 2 3 4



VERTICAL MULTI-LEVEL LIQUID LEVEL SWITCH SPECIFICATION SHEET

INSTRUCTIONS

Complete Process Conditions (Table 1). Select float design, stem material and watt rating (Table 2). Select mounting configuration (Table 3). Provide required dimensions and switch operation (Table 4). Mail or fax with purchase order to Madison Company.

All measurements in parentheses are in millimeters.

TABLE 1 PROCESS CONDITIONS

MAX. TEMP. _____ MIN. TEMP. _____

MAX. PRESSURE _____ SPECIFIC GRAVITY _____

FLUID _____

SPECIAL COND. _____

QUANTITY _____ WIRE LENGTH _____
24" (609.6 mm) standard

TABLE 3 MOUNTING CONFIGURATIONS*

MALE THREAD <input type="checkbox"/> 1/8" NPT <input type="checkbox"/> 1/4" NPT <input type="checkbox"/> 3/8" NPT <input type="checkbox"/> 1/2" NPT <input type="checkbox"/> 3/4" NPT	MALE PIPE PLUG <input type="checkbox"/> 2" <input type="checkbox"/> 1-1/2" <input type="checkbox"/> 1-1/4"	FLANGE <input type="checkbox"/> SPECIFY SIZE: _____ BULKHEAD FITTING <input type="checkbox"/> BULKHEAD
---	--	--

**See Typical Installations on previous page.*

TABLE 4 LENGTH & OPERATING POINT

For switches with bent stems, specify horizontal distance.

LH = _____

Please specify lengths and switch operation in chart below, always starting with the bottom switch (L5).

LENGTHS REQUIRED	SWITCH OPER. NO/NC	SPDT*	SLOSH SHIELD
L1 _____	<input type="checkbox"/>	<input type="checkbox"/>	<input type="checkbox"/>
L2 _____	<input type="checkbox"/>	<input type="checkbox"/>	<input type="checkbox"/>
L3 _____	<input type="checkbox"/>	<input type="checkbox"/>	<input type="checkbox"/>
L4 _____	<input type="checkbox"/>	<input type="checkbox"/>	<input type="checkbox"/>
L5 _____	<input type="checkbox"/>	<input type="checkbox"/>	<input type="checkbox"/>
L (Total) = _____			

* Full size floats only.

Refer to Switch Set-up Criteria on page 5 in order to determine lengths required.

TABLE 2

FLOAT DESIGN	AVAILABLE STEM MATERIALS	MODEL NO.
Full Size Floats		
SPST 60 WATTS SPST 100 WATTS	SPDT 25 WATTS <i>*Rated for hazardous locations.</i>	
<input type="checkbox"/> STAINLESS STEEL	<input type="checkbox"/> STAINLESS STEEL <input type="checkbox"/> BRASS	*M5602 M5402
<input type="checkbox"/> POLYPROPYLENE	<input type="checkbox"/> POLYPROPYLENE <input type="checkbox"/> STAINLESS STEEL <input type="checkbox"/> BRASS	M8802 M8602 M8402
<input type="checkbox"/> BUNA-N	<input type="checkbox"/> STAINLESS STEEL <input type="checkbox"/> BRASS	M4602 M4302
<input type="checkbox"/> KYNAR	<input type="checkbox"/> KYNAR	M9802
Miniature Size Floats SPST 30 WATTS		
<input type="checkbox"/> STAINLESS STEEL	<input type="checkbox"/> STAINLESS STEEL <input type="checkbox"/> BRASS	M5002 M5042
<input type="checkbox"/> POLYPROPYLENE	<input type="checkbox"/> POLYPROPYLENE <input type="checkbox"/> STAINLESS STEEL <input type="checkbox"/> BRASS	M8080 M8002 M8042
<input type="checkbox"/> BUNA-N	<input type="checkbox"/> STAINLESS STEEL <input type="checkbox"/> BRASS	M4402 M4502
<input type="checkbox"/> KYNAR	<input type="checkbox"/> KYNAR	M9090

We are proud supplier for the following completed and on going projects :



McGill College
845 Rue Sherbrooke O,
Montréal, QC H3A 0G4



51 Astor
25 Cooper St, New York,
NY 10034, United States



Telus Rimouski
419 Boul Jessop
Local 620, Rimouski, QC



La Maison Simons
977 Rue Ste-Catherine O,
Montréal, QC H3B 4W3

Sales and Service:

Quebec, Canada
Tel. : (450) 621-2995
Fax : (450) 621-4995

Lake Worth
Florida, USA
33467-5749

Toronto, Canada
Tel. : +1 (647) 544-2995

www.flofab.com

SERVICE 24/7 : parts@flofab.com

