

CONTROL PANEL	
ITEM 9	POSITION
<input type="checkbox"/>	0°
<input type="checkbox"/>	90°
<input type="checkbox"/>	180°
<input type="checkbox"/>	270°
<input type="checkbox"/>	WALL MOUNTED

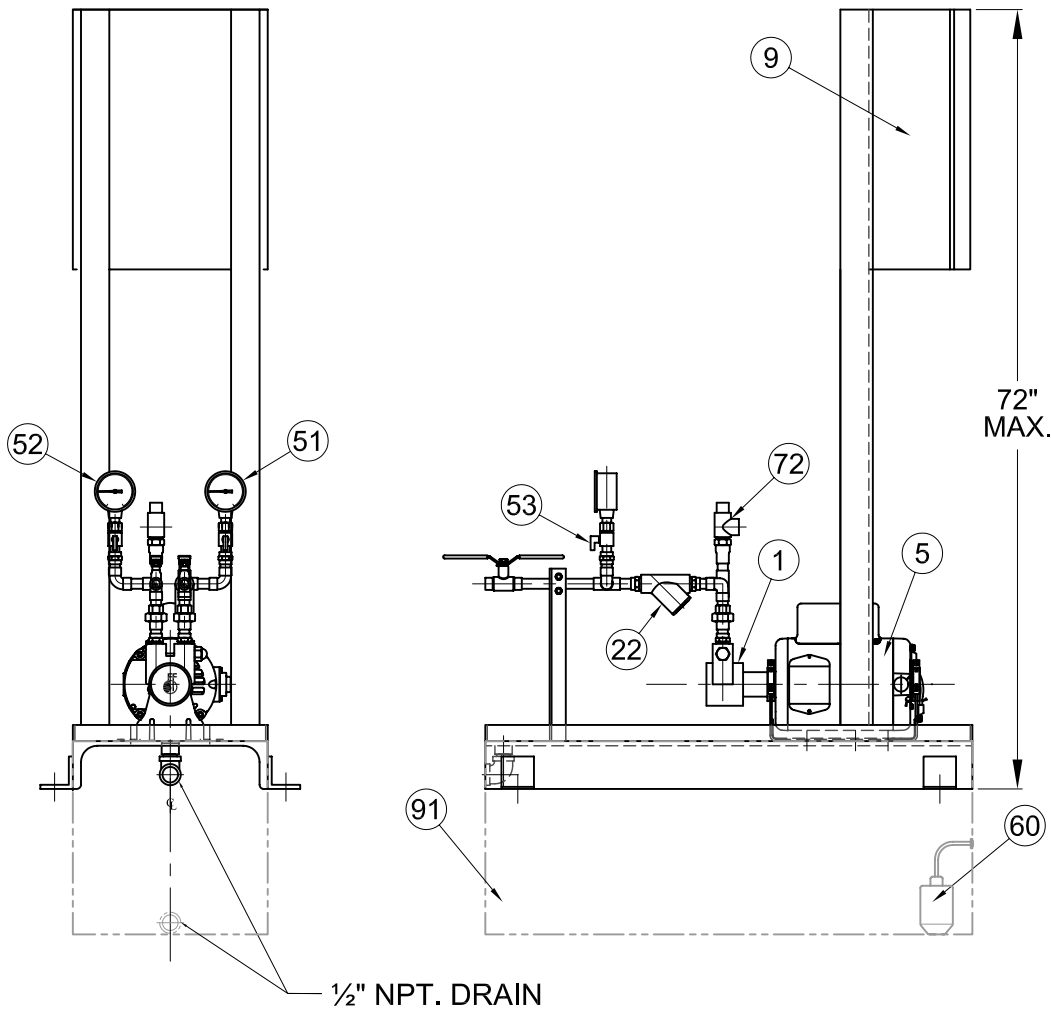

STANDARD	<input type="checkbox"/>	SY-FOM-CYS16-170
	<input type="checkbox"/>	SY-FOM-CYS16-295
	<input type="checkbox"/>	SY-FOM-CYS16-377
	<input type="checkbox"/>	SY-FOM-CYS16-560
	<input type="checkbox"/>	SY-FOM-CYS16-1026
OPTIONS	<input type="checkbox"/>	SY-FOM-R-CYS16-170
	<input type="checkbox"/>	SY-FOM-R-CYS16-295
	<input type="checkbox"/>	SY-FOM-R-CYS16-377
	<input type="checkbox"/>	SY-FOM-R-CYS16-560
	<input type="checkbox"/>	SY-FOM-R-CYS16-1026

TITLE / TITRE			
FLO FAB FUEL OIL TRANSFER SYSTEM SERIES "FOM"			
FF FLO FAB AQUA PROFAB 860 BOULEVARD INDUSTRIEL BOIS-DES-FILION, QC J6Z 4V7, (450) 621-2995		ENGINEER / INGÉNIEUR	
		CUSTOMER / CLIENT	
DRAWN BY / DESSINATEUR		SCALE / ECHELLE	DRAWING N° / N° DESSIN
M. LYMBURNER		N / A	S-FOM-SUBMITTAL
		DATE / DATE	REV
		APRIL 2007	0

NO	QTY	DESCRIPTION	SIZE	PART NUMBER
1	1	PUMP 1		
5	1	M1 MOTOR		
9	3	PANEL CONTROL		
22	1	NO. 1 Y-STRAINER		
29	3	BALL VALVE C X C		
38	1	NO. 1 DISCHARGE CHECK VALVE		
51	1	SUCTION PRESSURE GAUGE		
52	1	DISCHARGE PRESSURE GAUGE		
53	1	PET COCKS		
60	1	LEVEL FLOAT		
72	1	PRESSURE RELIEF VALVE		
86	1	STEEL FABRICATED BASEPLATE		
91		RESERVOIR TANK		

TITLE / TITRE	
FLO FAB - SIMPLEX "FOM"	
MATERIAL LIST	

 FLO FAB AQUA PROFAB	PROJECT / PROJET
	CUSTOMER / CLIENT
	DRAWING N° / N° DESSIN
860 BOULEVARD INDUSTRIEL BOIS-DES-FILION, QC J6Z 4V7, (450) 621-2995	DATE / DATE

MAY 2007

REV	DESCRIPTION	DATE	INIT.	DRAWN BY / DESSINATEUR	SCALE / ECHELLE	PART LIST N° / LISTE DE MATERIEL N°	REV
				M. LYMBURNER	N / A		0