

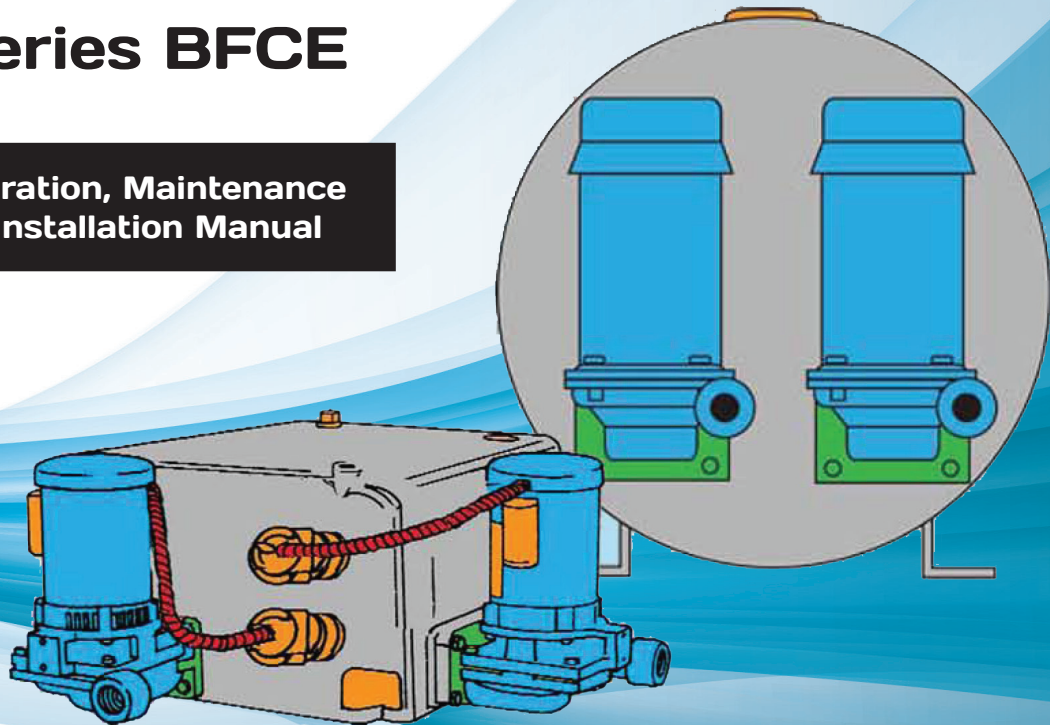

Boiler Feed Unit Systems

Series BFCE

Operation, Maintenance
& Installation Manual



BOILER FEED UNITS TYPE "BFC"

- Completely Assembled units
- Application Flexibility
- Quiet operation

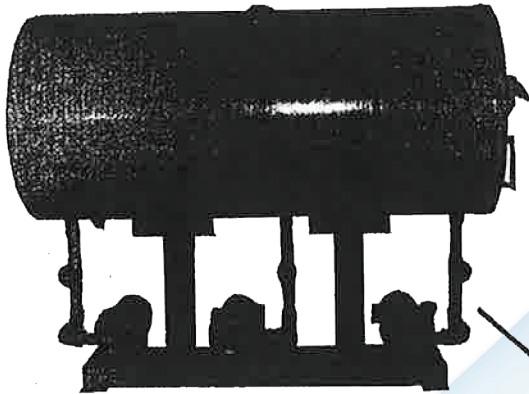

Features

- Simplex, duplex, or multiplex units
- Ratings to 1000 boiler H.P.
- Up to 60 P.S.I.G. discharge pressure
- 3500 RPM & 1750 RPM
- Reliable single stage pump
- FLO FAB exclusive Hydro-Lock wearing ring for low NPSH requirement
- Stainless steel shaft sleeve with short length minimizing deflection under load
- Pump casing close grained cast Iron
- Impeller one piece cast bronze precision balanced
- Copper bearing steel receiver
- Integral make-up water valve

Options

- Copper bearing steel receivers with Interior apexior, dura-therm coating
- Galvanized steel receivers
- ASME Receivers
- Multi stage vertical or horizontal pump offering low NPSH requirement and pump curve characteristics as required
- Two stage units for 2' NPSH requirement
- CHC units designed to operate in condensate return applications

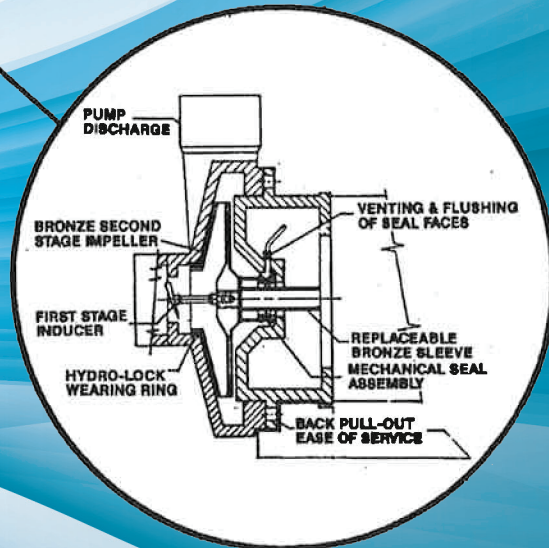

TWO STAGE PUMP & SHOWN ABOVE ARE OPTIONAL

FLO FAB Hydro-Lock Wearing Ring is to prevent recycling of high pressure water into suction of the Impeller, thereby permitting less NPSH requirement. This is a standard feature of our boiler feed unit.



BOILER FEED UNITS TYPE "BFC"

ENGINEERING SELECTION PROCEDURE

1. Determining piping arrangement to be used from Table No. 1.
2. From data listed In Table No. 2 select GPM capacity of pump. If one pump is feeding more than one boiler add total load.
3. Determine the discharge pressure (convert all into pounds per square inch) of the pump by taking into consideration
 - A. Boiler maximum operating pressure;
 - B. Add static lift.
 - C. Add friction loss thru pipe valves, fittings and accessories.
 - D. Add 5 P.S.I. to the sum of the above.
4. Select Unit from Table No. 3
5. Determine receiver size. As a standard, consider a minimum of one gallon storage per total connected boiler horsepower. If steam runs are connected to remote loads a consideration should be made to Increase the size of the receiver to two gallon storage per boiler horse power. For usual applications consult factory or boiler manufacturer
6. Select receiver material copper bearing steel or stainless steel.
7. Select mechanical accessories and modifications.
8. Select electrical characteristics and control modifications:
 - A. Motor voltage.
 - B. Control panel arrangement.

TABLE NO.1 - PIPING ARRANGEMENT SELECTION

NO.	SCHEME	BOILER FEED UNIT	PUMP CAPACITY	REMARKS	ELECTRICAL OPTIONS
1		SIMPLEX	SINGLE		
2		DUPLEX	SINGLE	ONE PUMP STAND BY	FOR EQUAL OPERATION OF PUMPS: 1 - MANUAL TRANSFER 2 - AUTOMATIC ALTERNATOR
3		DUPLEX	SINGLE		
4		TRIPLEX	SINGLE	ONE PUMP STAND BY	MANUAL TRANSFER SWITCH FOR STANDBY PUMP TO BE ACTIVATED FOR EITHER BOILER
5		DUPLEX	DUAL	EACH PUMP CAPACITY SUFFICIENT FOR TWO BOILERS	FOR EQUAL OPERATION OF PUMPS: 1 - MANUAL TRANSFER 2 - AUTOMATIC ALTERNATOR

For operational schemes other than shown, consult FLO FAB engineering department or boiler manufacturer.

1. All pump discharges must be provided with check valves.
2. Multiples and variations may be selected.
3. Careful consideration should be given to provide standby operation and sufficient receiver capacity.
4. For details of connections to boilers, refer to boilers manufacturer literature and piping diagrams.
5. Electrical controls shall be coordinated with boiler level controller.

EQUIPMENT FEATURES

UNIT IS FACTORY ASSEMBLED AND INCLUDES THE FOLLOWING:

Steel receiver on pedestal mounted steel base, standard openings, suction line, sediment separator, gauge glass with shot off cocks, thermometer, FLO FAB make-up water valve assembly with "Y" strainer and pump(s).

PUMP: A single-stage, low NPSH requirement or, as an option, 2-stage 2' low NPSH pump with close grained cast iron casing leakless mechanical shaft seal, stainless steel large diameter corrosion resistant shaft, with the FLO FAB Exclusive Hydro-Lock wearing ring.

MOTOR: Open-drip-proof motor, standard NEMA construction, Totally enclosed and explosion-proof motors are available. Motor bearings are sealed and factory greased for extra long trouble-free operation. Single phase fractional HP motors include built-in thermal overload protection. Motors available 3500 RPM and 1750 RPM.

RECEIVER: Copper bearing steel receiver mounted on steel pedestal, with inlet, vent, and drain. Fitted with standard accessories.

MAKE-UP WATER VALVE: All-bronze float actuated valve, flange mounted In tank head, permits entry of make-up water, when required, to replace system losses. Complete with strainer on make-up water connection.

OPERATION: Boiler feed pump(s) is controlled by a boiler water level controller mounted on the boiler. These controllers are usually furnished with integral low water cut-off and alarm switches. Boiler feed water is taken from the receiver, and if condensate, has been lost in the system. It Is automatically replaced by the makeup valve. ~

MECHANICAL MODIFICATIONS

1. FLO FAB type 'BFC' boiler feed units can be furnished as e CHC Condensate Unit by substituting float switch or mechanical alternator for cold water make-up valve assembly.
2. Copper bearing steel receiver with interior, epexior, dura-therm coating.
3. Galvanized steel receiver.
4. ASME Receiver.
5. Non-standard receiver sizes.
6. Special receiver tappings.
7. Manhole in receiver.
8. Drain valve on tank drain connection.
9. Special internal make-up valves.
10. External float chamber make-up valve with 3-valve bypass.
11. Solenoid operated make-up valve with or without 3- valve bypass.
12. Corrosion inhibitor bar in receiver.
13. Steam Injection pipe with venturi. Operated by temperature regulating valve with sensor.
14. Discharge pressure gauges.
15. «Y» strainers to pump suction.
16. Shut off valves to pump suction.
17. Overflow siphon breaker.
18. Two stage pumps for 2' NPSH requirement.



ELECTRICAL MODIFICATIONS

TABLE NO.2 - CAPACITY SELECTION

Boiler H.P.	Evap. rate GPM	Pump GPM	Steam Sq. Ft.	BTU/HP (1000's)	Steam Lbs/hr
15	1	3	1.568	502	517
30	2	6	3.135	1.040	1.034
50	35	10	5.225	1.674	1.725
75	5	15	7.638	2.510	2.587
100	7	21	10.450	3.348	3.450
150	10.5	31	15.675	5.022	5.175
200	14	42	20.900	6.698	6.900
300	21	63	31.350	10.044	10.350
400	28	84	41.800	13.392	13.800
500	35	105	52.250	16.740	17.250
750	52.5	158	78.375	25.110	25.875
1000	70	210	104.500	33.480	34.500

- Totally enclosed motors or explosion-proof motors.
- Transfer switches to alternate pump operation or transfer pump-boiler relationship in multiple-boiler installations. (See Table No. 1)
- Various magnetic starter arrangements Including: duplex control panels, combination starters with various forms of disconnects, hand-off-auto switches, pilot lights and transformers providing low control voltage.
- High water alarm or low water alarm (FLO FAB tank alert) actuated by float switch.

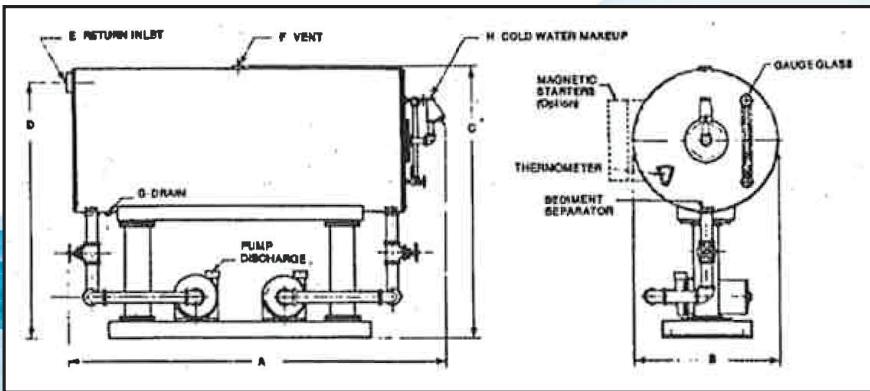

• For concrete pad dimensions, use overall size of receiver.

DIMENSIONS : INCHES

Receiver Cap. Gal.	Receiver Size	A	B	C	D	E	F	G	H
70	24 x 36	42	24	42	39	3	1 1/2	1	1/2
116	24 x 60	66	24	42	39	3	1 1/2	1	1/2
200	30 x 66	72	30	54	50	4	2	1	3/4
300	36 x 66	72	36	60	56	4	2	1	3/4
390	36 x 84	90	36	60	56	4	2	1	3/8
515	48 x 66	72	48	72	68	4	2	1	1
750	48 x 96	102	48	72	68	4	3	2	1
1002	48 x 128	134	48	72	68	4	3	2	1

• On special order dimensions may be altered

Subject to Engineering Department approval

TABLE NO.3 - SELECTION TABLE

✓	Model Number	Boiler B.F.	Pump GPM	PSI Disch. Pressure	Motor HP		Receiving Tank Cap. Gal.	PUMP Disch. Size	
					3580 RPM	1750 RPM		3580 RPM	1750 RPM
	BFC - 1520	15	3	20	1/3	1/2	70 24" x 36"	1	3/4
	BFC - 1530			30	1/8	1 1/2		1	3/4
	BFC - 1540			40	1	2		1 1/4	3/4
	BFC - 1550			50	1 1/2	5		1 1/4	1
	BFC- 3020	30	6	20	1/8	1/2	70 24" x 36"	1	3/4
	BFC- 3030			30	1/2	1 1/2		1	3/4
	BFC- 3040			40	1	2		1 1/4	3/4
	BFC- 3050			50	1 1/3	5		1 1/4	3/4
	BFC- 5020	50	10	20	1/8	1/2	70 24" x 36"	1	3/4
	BFC- 5030			30	1/2	1 1/2		1	3/4
	BFC- 5040			40	1	2		1 1/4	3/4
	BFC- 5050			50	1 1/3	5		1 1/4	3/4
	BFC - 7520	75	15	20	1/3	1/2	116 24" x 60"	1	3/4
	BFC - 7530			30	3/4	1 1/2		1 1/4	3/4
	BFC - 7540			40	1	2		1 1/4	3/4
	BFC - 7550			50	1 1/2	5		1 1/4	3/4
	BFC - 7560			60	3	----		1 1/4	----
	BFC - 7580			80	5	----		1 1/3	----
	BFC - 10020	100	21	20	1/8	3/4	116 24" x 60"	1	1
	BFC - 10030			30	3/4	1 1/2		1 1/4	1
	BFC - 10040			40	1 1/8	2		1 1/4	3/4
	BFC - 10050			50	2	5		1 1/4	1
	BFC - 10060			60	3	----		1 1/3	----
	BFC - 10080			80	5	----		1 1/2	----
	BFC - 15020	150	31	20	1/2	3/4	200 30" x 66"	1	1
	BFC - 15030			30	3/8	2		1 1/4	1
	BFC - 15040			40	1 1/3	3		1 1/4	1
	BFC - 15050			50	2	5		1 1/4	1
	BFC - 15060			60	3	----		1 1/2	----
	BFC - 15080			80	5	----		1 1/3	----

TABLE NO.3 - SELECTION TABLE (...CONTINUING)

✓	Model Number	Boiler B.F.	Pump GPM	PSI Disch. Pressure	Motor HP		Receiving Tank Cap. Gal.	PUMP Disch. Size	
					3580 RPM	1750 RPM		3580 RPM	1750 RPM
	BFC - 20020	200	42	20	3/4	3/4	200 30" x 66"	1 1/4	3/4
	BFC - 20030			30	1	2		1 1/4	1
	BFC - 20040			40	1 1/2	3		1 1/4	1
	BFC - 20050			50	2	5		1 1/4	1
	BFC - 20060			60	3	----		1 1/2	----
	BFC - 20080			80	5	----		1 1/2	----
	BFC - 30020	300	63	20	1	1 1/2	300 36" x 66"	1 1/4	1 1/4
	BFC - 30030			30	1 1/2	2		1 1/4	1
	BFC - 30040			40	2	3		1 1/4	1
	BFC - 30050			50	3	5		1 1/2	1
	BFC - 30060			60	5	----		1 1/2	----
	BFC - 30080			80	7 1/2	----		1 1/2	----
	BFC - 40020	400	84	20	1 1/2	1 1/2	390 36" x 84"	1 1/4	1 1/4
	BFC - 40030			30	2	3		1 1/4	1 1/4
	BFC - 40040			40	3	5		1 1/2	1 1/4
	BFC - 40050			50	5	7 1/2		1 1/2	1 1/4
	BFC - 40060			60	7 1/2	----		1 1/2	----
	BFC - 40080			80	7 1/2	----		1 1/3	----
	BFC - 50020	500	105	20	2	2	515 48" x 66"	1 1/2	1 1/8
	BFC - 50030			30	3	5		1 1/2	1 1/4
	BFC - 50040			40	5	5		1 1/8	1 1/4
	BFC - 50050			50	5	7 1/2		1 1/8	1 1/8
	BFC - 50060			60	7 1/2	----		1 1/2	----
	BFC - 75020	750	158	20	3	3	750 48" x 96"	1 1/8	1 1/2
	BFC - 75030			30	3	5		1 1/2	1 1/4
	BFC - 75040			40	5	7 1/2		1 1/2	1 1/2
	BFC - 75050			50	7 1/2	10		1 1/2	1 1/8
	BFC - 75060			60	10	----		1 1/4	----
	BFC - 100020	1000	210	20	5	5	1002 48" x 128"	1 1/8	1 1/2
	BFC - 100030			30	5	7 1/2		1 1/2	1 1/2
	BFC - 100040			40	7 1/2	10		1 1/2	1 1/2
	BFC - 100050			50	10	15		1 1/2	1 1/2
	BFC - 100060			60	15	----		1 1/3	----

BOILER FEED UNITS TYPE "BFC"

SUGGESTED SPECIFICATIONS FOR ARCHITECTS AND ENGINEERS

Furnish and install where indicated on plans a Type BFC Simplex (or Duplex; Multiplex) Boiler Feed Unit as manufactured by FLO FAB, Unit No. BFC - _____, sized to provide feed water to _____ boiler(s), (each) developing _____ boiler H.P. (Each) pump shall deliver _____ G.P.M. at a discharge pressure of _____ PSIG at the pump(s).

Unit shall be factory assembled by the pump manufacturer, including receiver and accessories plus pump(s) and motor(s) all mounted on a single steel base with pump suction piping complete.

Pump(s) shall be close-coupled, end-suction, bronze fitted, centrifugal type with balanced and enclosed impeller, leakless _____ R.P.M. ball bearing, drip-proof (or totally enclosed; explosion-proof) motor(s). Single phase motor in fractional H.P. frame sizes shall have built-in thermal overload protection. Single phase motors in integral H.P. frame size and all three phase motors shall be provided with across-the-line type manual-reset magnetic starters in NEMA 1 general purpose (or NEMA 4 Watertight, NEMA 7 Explosion-proof). Starters shall be mounted and wired to motors.

Receiver shall be off heavy steel construction, with sediment separator, gauge glass, thermometer, end connections for return, vent and drain. Makeup water valve, flange-mounted on tank head, shall be of all-bronze construction, float operated with makeup water strainer. Receiving tank capacity shall be _____ gallons.

Furnish and install on (each) boiler a boiler water level controller to automatically operate the pump(s), with low-water cut-off and alarm switch, plus alarm bell. Controller shall be equal to McDonnell-Miller No. 150 (for boiler pressure up to 150 P.S.I.) or No. 94 (for boiler pressures up to 250 P.S.I.). (Controllers not furnished by FLO FAB Pump.)

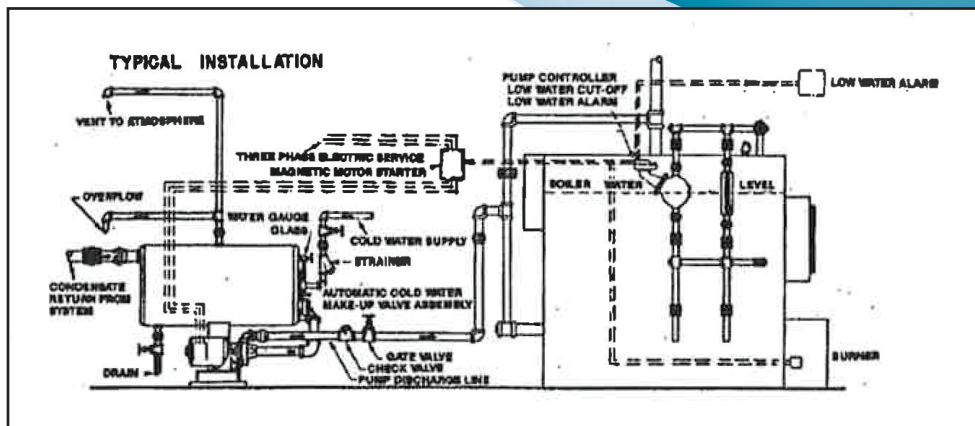



BOILER FEED UNITS MAKEUP WATER ASSEMBLY

WITH SOLENOID OPERATED VALVE & AIR GAP

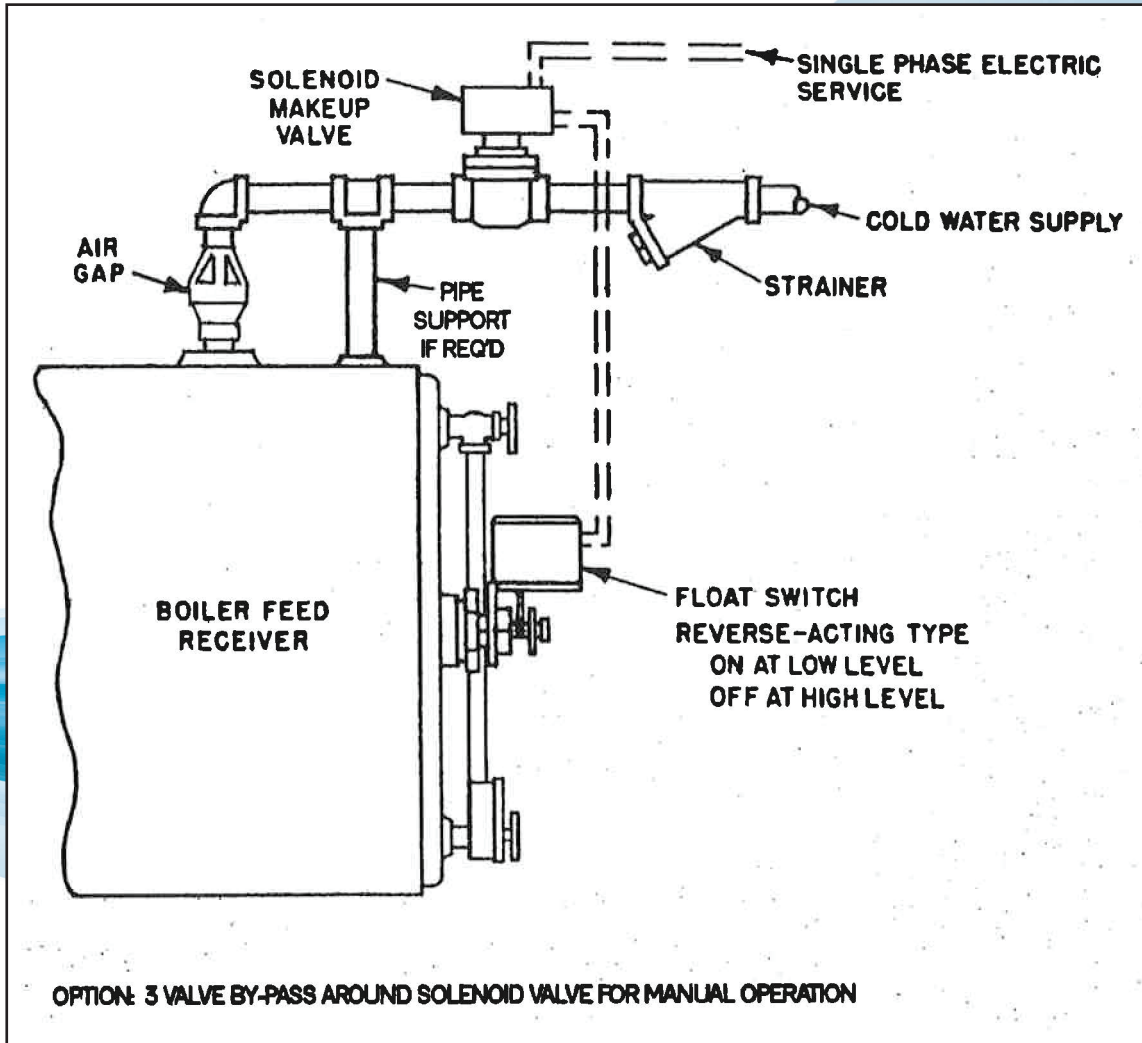



BOILER FEED UNITS TYPE "BFC"

ENGINEERS SPECIFICATIONS

Furnished and install where indicated on plans, a Type BFC Simplex /Duplex I Multiplex Boiler Feed Unit, as manufactured by FLO FAB, Unit No. BFC- _____ Sized to provide feed water to _____ boiler(s), (each) developing _____ boiler H.P. (each) pump shall deliver _____ G.P.M. at a discharge pressure of _____ PSIG at the pump(s). Unit shall be factory assembled by the pump manufacturer, including receiver and accessories plus pump (s) and motor(s) all mounted on a single steel base with pump suction piping complete.

Pump (s) shall be close-coupled, end-suction, bronze fitted, centrifugal type with balanced and enclosed impeller, leakless mechanical shaft seal and bronze shaft sleeve; drive by _____ H.P., _____ phase, cycle, _____ volts, _____ R.P.M. ODP/TEFC/XP motor (s). Single phase motors in fractional H.P. frame sizes shall have built-in thermal overload protection. Starters shall be mounted and wired to motors.

Receiver shall be of heavy steel construction, with sediment separator, gauge glass, thermometer, and connection for return, vent and drain. Makeup water valve, flange-mounted on tank head, shall be of all-bronze construction, float operated with makeup water strainer. Receiving tank capacity shall be _____ gallons.

Furnished and install on (each) boiler water level controller to automatically operate the pump (s), with low-water cutoff and alarm switch, plus alarm bell. Controller shall be equal to McDonnell-Miller No. 94 (for boiler pressures up to 250 P.S.I.). (Controllers not furnished by FLO FAB)

Furnished one (1) control panel as described on page 5-X-090-E1. The panel shall be mounted and wired to unit. The control panel shall bear the label of Underwriter Laboratories signifying that all work performed by the manufacturer is in compliance with the requirements of Underwriters Laboratories . Approval of just the enclosure or electrical devices shall be unacceptable.

All wiring and electrical construction within the panel must conform to U.L. requirements.

We are proud supplier for the following completed and on going projects :



Las Positas College
3000 Campus Hill Dr,
Livermore, CA, USA
94551



The West Mall
25 The West Mall,
Toronto, ON
M9C 1B8



Baliscus
1075 Grand Héron Boul.,
Saint-Jérôme, QC, CA
J5L 1G2



**Montréal - P.E.T
International Airport,**
975 boul. Roméo-Vachon
Dorval, Quebec, H4Y 1H1

Sales and Service:

Quebec, Canada
Tel. : (450) 621-2995
Fax : (450) 621-4995

Lake Worth
Florida, USA
33467-5749

Toronto, Canada
Tel. : +1 (647) 544-2995

www.flofab.com

SERVICE 24/7 : parts@flofab.com

