



# Boiler Feed Unit Systems

**CVC Series**

**BCF Series**

**BCFE Series**

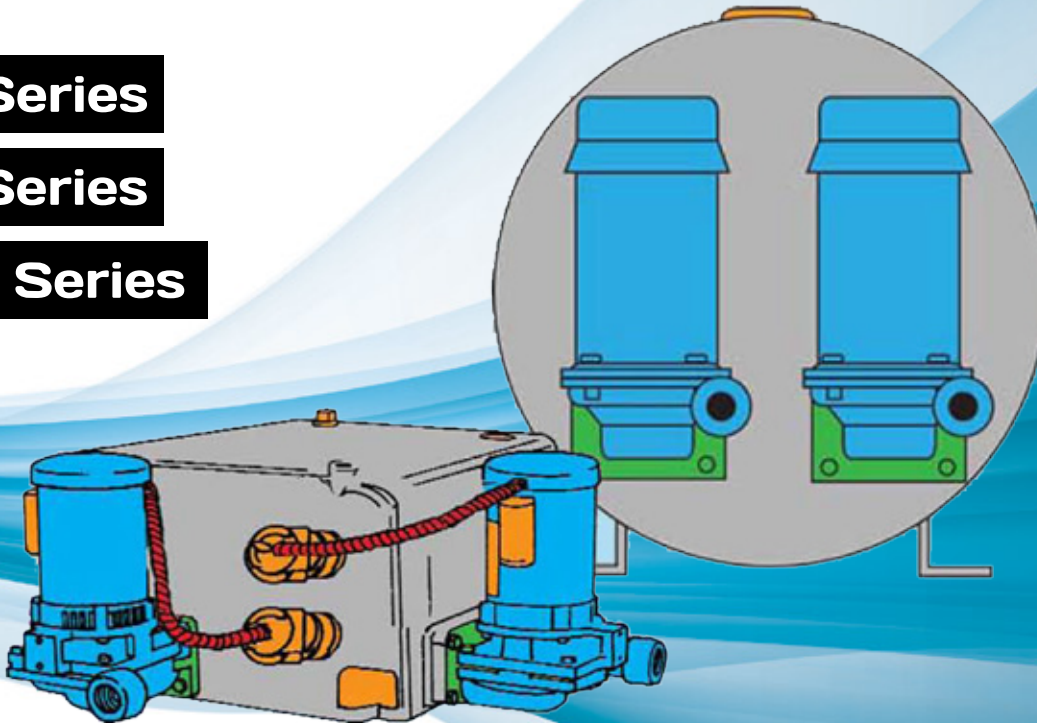

**Condensate & Boiler Feed Units**  
**Series "CVC" - Condensate**  
**"BFC" - Boiler Feed**  
**"BFCE" - Elevated Boiler**

[www.flofab.com](http://www.flofab.com)

001-cat-2017-bfus

Go to [www.flofab.com](http://www.flofab.com) in Our Products Section to see the Master Spec - <http://www.arcomnet.com/masterspec/>

# TABLE OF CONTENT

<b>BOILER FEED OR MAKE-UP PUMPS STANDARD EQUIPMENTS / OPTIONAL EQUIPMENT.....</b>	<b>2</b>
<b>FLO FAB CENTRIFUGAL PUMP SERIES GV / RECEIVER TANKS / CONTROL / MOTORS.....</b>	<b>3</b>
<b>BOILER FEED UNIT : <b>SERIES BFC</b>.....</b>	<b>4</b>
<b>ELEVATED BOILER FEED UNIT : <b>SERIES BFCE</b>.....</b>	<b>5</b>
<b>BOILER FEED UNIT : SELECTION TABLES (3450 RPM).....</b>	<b>6-7</b>
<b>BOILER FEED UNIT : SELECTION TABLES (1750 RPM).....</b>	<b>8-9</b>
<b>CONDENSATE RETURN UNIT <b>SERIES CVC</b> / BOILER FEED UNIT <b>BFC</b> OR <b>BFCE</b>.....</b>	<b>10</b>
<b>CONTROL PANELS : <b>SERIES DCP &amp; DCP-B</b>.....</b>	<b>11</b>
<b>TYPICAL SPECIFICATIONS FOR SERIES <b>CVC - BFC - BFCE</b>.....</b>	<b>12</b>
<b>SUBMITTAL DATA SHEET.....</b>	<b>13-14-15</b>

## HISTORY

Flo Fab was established in 1981 by Denis Gauvreau who created and developed the products line and constantly being perfected by Marc Gauvreau, as well as by a team of professional engineers and designers. It's a combination of existing designs from several renowned products and the innovative ideas of a new generation professionals.

Through the years, Flo Fab has acquired several companies and service entities including : AQUA-PROFAB (ASME Tanks manufacturer), MÉNARD, LÉONARD ÉLECTRIQUE, PMA. , Furthermore Flo Fab purchased equipment, fabrication designs and patterns from IDEALCO, a manufacturer of shell and tube type heat exchangers.

The after sales services, sales, engineering, R&D, production, quality control, accounting and administration departments of all the above companies share the same location.

In December 2014, Marc Gauvreau, son of the founder, acquired all shares of The company. Flo Fab and is constantly investing in new state of the art innovations new product like the XRI series and Prefab Skid for Hydronic Heating & cooling system, pumping systems. This has allowed Flo Fab to retain competent and experienced staff of professionals with varied and specialized abilities that constantly work on improving our existing products and add new engineered solutions that exceeding customer's expectations .

Flo Fab has grown quite rapidly and now proudly offers of a wide range of products available directly from one manufacturer. This includes pumps & pump packages, tanks, heat exchangers & hydronic accessories. This allows each project stakeholders to enjoy economical savings, peace of mind, best value for their investment and optimized total cost of ownership.



The FLO FAB pumping systems described in this brochure are packaged units, completely assembled, wired and tested at the manufacturing plant. They are designed to provide maximum efficiency, reliability and easy maintenance in compact, space saving configurations.

Each unit is individually factory tested before shipment to assure that the product is ready for service when it is received. Testing includes verification of flow rate, pressure, amperage draw and cut-in/cut-out points of all components.

**Technical assistance.** Your FLO FAB representative has the expertise to assist you in selecting the pumping system most suitable for your application. He is backed by a team of engineers and application specialists who can develop the most efficient, energy saving pumping system for your specific requirements.

**Series BFC and BFCE boiler feed pumps** are used to pump and precisely control the condensate and make-up water required by the boiler(s) in low pressure steam applications. Pumping action is controlled by the fluid level in the boiler. They consist of a welded steel storage receiver equipped with make-up valve and one or more centrifugal pump(s) which are closed-coupled to an electric motor.

## ● Boiler Feed Or Make-Up Pumps Standard Equipement

- 1) Float operated make up valve.
- 2) Gauge glass and thermometer
- 3) Suction isolation Butterfly valve(s)  
(on BFCE units only)
- 4) Inlet strainer(s) - "Y"  
(on BFCE units only)
- 5) Metal flexible  
(on BFCE units only)

## ● Optional Equipement

- Control panels
- Make-up feeders - external type, or reverse acting float switch and solenoid valve type
- Solenoid operated make-up valve with float switch
- Magnesium corrosion inhibitor
- Three valve bypass and inlet strainer assembly
- Feedwater preheaters (Steam Injectors)
- Discharge pressure gauges
- Discharge check valves
- Discharge gate valves
- Discharge butterfly valves

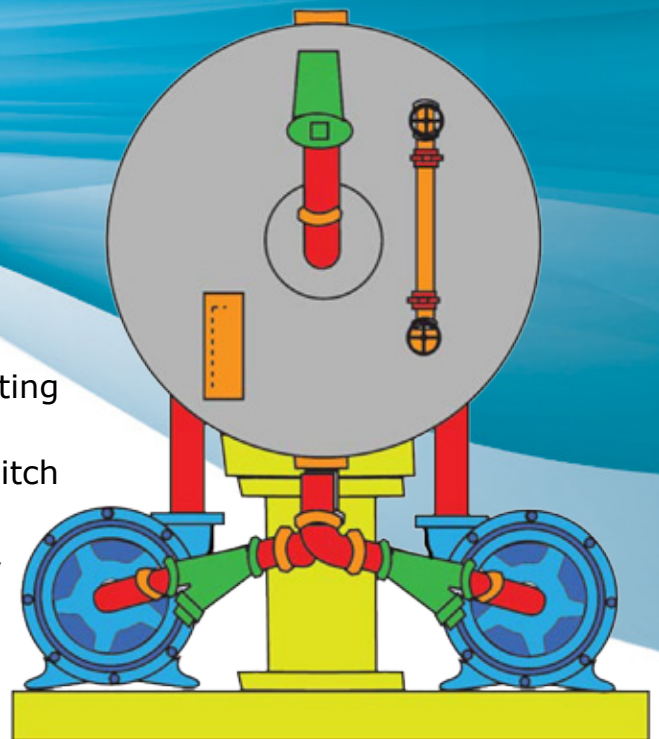

**DUPLEX (D-BFCE)  
ELEVATED BOILER FEED UNIT**



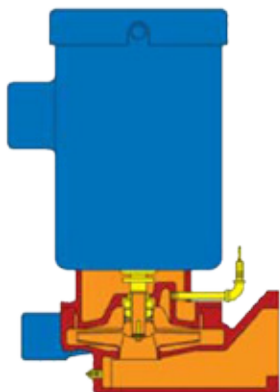

**CENTRIFUGAL PUMP SERIES GV**

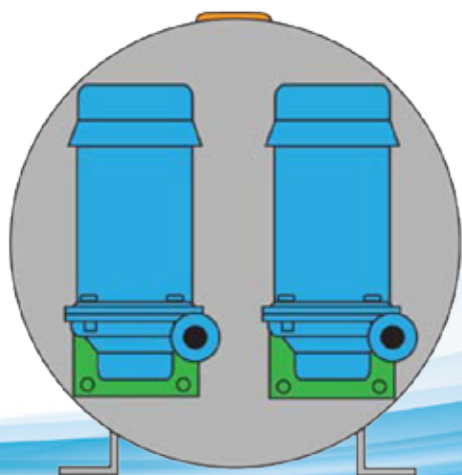

**DUPLEX (D-BFC) BOILER FEED UNIT**

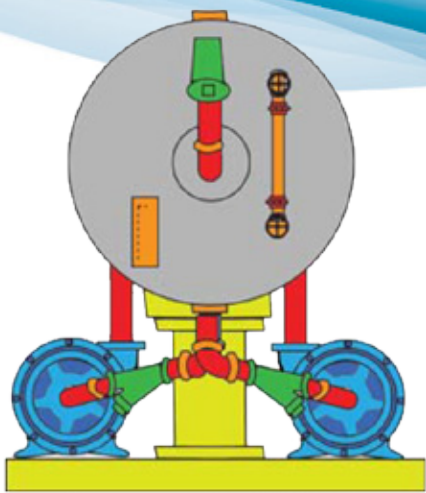

**DUPLEX (D-BFCE)  
ELEVATED BOILER FEED UNIT**

**FLO FAB CENTRIFUGAL PUMP SERIES GV**

Vertically flange mounted centrifugal pumps are of bronze fitted construction with mechanical shaft seal for temperatures up to 250oF (up to 300oF also available). The pump is directly bolted to the receiver tank to provide a compact, efficient design. Seal area is automatically vented and flushed to the receiver to assure adequate lubrication at all times. Back pull-out design allows servicing without disturbing the piping. Bronze enclosed impellers are precision balanced for smooth, quiet operation. Each unit is factory assembled and tested prior to shipping.

**RECEIVER TANK**

Rugged steel or cast iron receivers for life-time service under the most severe conditions. Low return inlet to provide adequate drainage of radiators with low elevation. Available in 50, 70, 120, 210, 300 gallons sizes. Larger sizes are also available. Condensate receiver tanks are designed for gravity return systems only, and are not to be pressurized. Tank must be vented to atmosphere to prevent pressure build-up in the tank. Vent size shall be at least 1 1/4» diameter.

**CONTROLS**

Simplex (S-BFC or S-BFCE) systems are equipped with a heavy duty adjustable float switch and a stainless steel float and rod. Duplex (D-BFC or D-BFCE) systems are equipped with an electrical alternator for alternating the pumps and to start the second pump if the first one fails or when flow rate exceeds capability of one pump. For boiler feed service the float switch, which is set to close contacts at low level, operates a water make-up valve. Both float switches are two pole devices with double break contacts. Control panel and magnetic starter also available.

**MOTORS**

Drip proof or TEFC NEMA standard 3450 RPM motors have dual ball bearings and threaded stainless steel shaft. All single phase motors have built-in thermal overload protection. All three phase motors must be installed with a magnetic starter which provides full overload protection. Failure to use proper starter and overload protectors will void warranty. Single phase motors thru 2Hp are 115 V or 230 V 60Hz (50 cycles also available) and 3Hp or more are 230 V only. Three phase motors are 230 V, 460 V or 575 V 60Hz (50 cycles also available).



# Boiler Feed Unit Series BFC

FLO FAB Series BFC boiler feed units are used to pump condensate and make-up water directly into the boiler(s). Pumping action is determined by a boiler mounted control which senses boiler water level requirements. Each boiler feed unit is equipped with a heavy duty make-up valve actuated by the position of its seamless float within the receiver. The mechanism is readily adjustable for various water levels. It is mounted on the end of the receiver and can be easily removed as a complete unit.

Simplex (S-BFC) or duplex (D-BFC) units are available with cylindrical welded steel receivers in 50, 70, 120, 210, 300 gallon capacities. Simplex (S-BFC) units are also available mounted on duplex receivers to provide the option for conversion to a duplex (D-BFC) unit at a future requirement. Standard equipment also includes a water level gauge glass and a stem thermometer. When ordering, specify model number and required voltage.

NOTE: Larger units available on request.

Receiver Size	Unit Type	B	C	D	E	F	G	H	I	J	K	L
50 Gallons	S-BFC	49"	22"	22"	37"	33"	18"	21"	2"	2"	4"	7 <sup>3</sup> / <sub>16</sub> "
	D-BFC	1244.6 mm	558.8 mm	558.8 mm	939.8 mm	838.2 mm	457.2 mm	533.4 mm	50.8 mm	50.8 mm	101.6 mm	182.9 mm
70 Gallons	S-BFC	47"	24"	24"	37"	31"	22"	25"	2"	2"	4"	6 <sup>7</sup> / <sub>8</sub> "
	D-BFC	1193.8 mm	609.6 mm	609.6 mm	939.8 mm	787.4 mm	558.8 mm	635 mm	50.8 mm	50.8 mm	101.6 mm	172.7 mm
120 Gallons	S-BFC	56"	28"	28"	46"	40"	26"	29"	2 <sup>1</sup> / <sub>2</sub> "	2 <sup>1</sup> / <sub>2</sub> "	4"	6 <sup>3</sup> / <sub>8</sub> "
	D-BFC	1422.4 mm	711.2 mm	711.2 mm	1168.4 mm	1016 mm	660.4 mm	736.6 mm	63.5 mm	63.5 mm	101.6 mm	162.6 mm
210 Gallons	S-BFC	81"	30"	30"	71"	65"	28"	31"	2 <sup>1</sup> / <sub>2</sub> "	2 <sup>1</sup> / <sub>2</sub> "	4"	6 <sup>3</sup> / <sub>8</sub> "
	D-BFC	2057.4 mm	762 mm	762 mm	1803.4 mm	1651 mm	711.2 mm	787.4 mm	63.5 mm	63.5 mm	101.6 mm	162.6 mm
300 Gallons	S-BFC	82"	36"	36"	72"	60"	32"	39"	3"	3"	6"	6 <sup>3</sup> / <sub>8</sub> "
	D-BFC	2082.8 mm	914.4 mm	914.4 mm	1828.8 mm	1524 mm	812.8 mm	990.6 mm	76.2 mm	76.2 mm	152.4 mm	162.6 mm

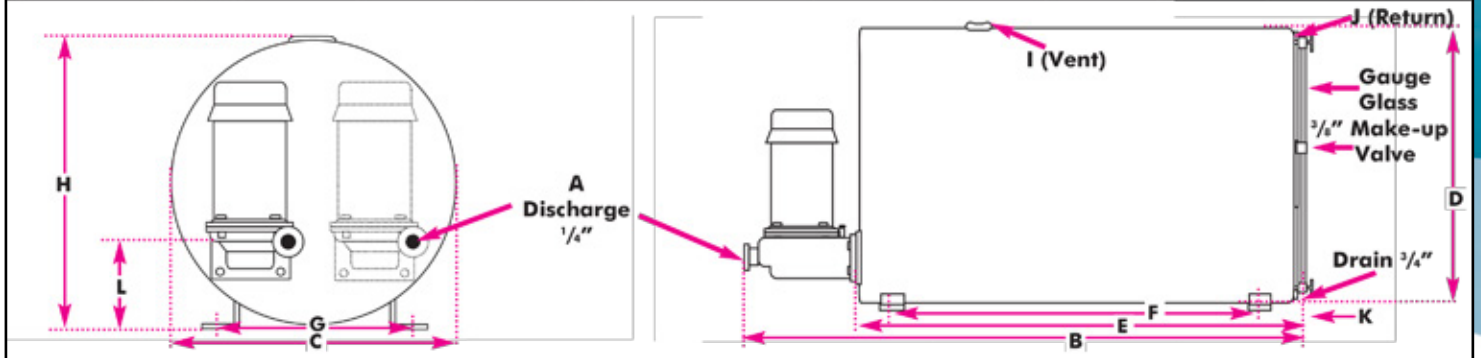

Dimensions not to be used for construction unless prints is certified by factory.

# • Elevated Boiler Feed Unit Series BFCE

All the same features as the regular boiler feed units series BFC. The BFCE also includes suction isolation butterfly valve(s), inlet «Y» strainer(s) and metal flexible(s) at pump inlet(s). The elevated boiler feed units series BFCE may be an option for small space location that requires special installation. The pump(s) and motor(s) are installed beside or under the tank instead of at the end(s) for a more compact, shorter design.

Receiver Size	Unit Type	A	B	C	D	E	F	G
50 Gallons	S-BFCE	44"	2"	2"	45"	3/4"	36"	50"
	D-BFCE	1117.6 mm	50.8 mm	50.8 mm	1143 mm	19.05 mm	914.4 mm	1270 mm
70 Gallons	S-BFCE	44"	2"	2"	47"	3/4"	36"	52"
	D-BFCE	1117.6 mm	50.8 mm	50.8 mm	1193.8 mm	19.05 mm	914.4 mm	1320.8 mm
120 Gallons	S-BFCE	53"	2 1/2"	2 1/2"	50"	3/4"	36"	56"
	D-BFCE	1346.2 mm	63.5 mm	63.5 mm	1270 mm	19.05 mm	914.4 mm	1422.4 mm
210 Gallons	S-BFCE	78"	2 1/2"	2 1/2"	52"	3/4"	36"	58"
	D-BFCE	1981.2 mm	63.5 mm	63.5 mm	1320.8 mm	19.05 mm	914.4 mm	1473.2 mm
300 Gallons	S-BFC	79"	3"	3"	66"	3/4"	42"	72"
	D-BFC	2006.6 mm	76.2 mm	76.2 mm	1676.4 mm	19.05 mm	1066.8 mm	1828.8 mm

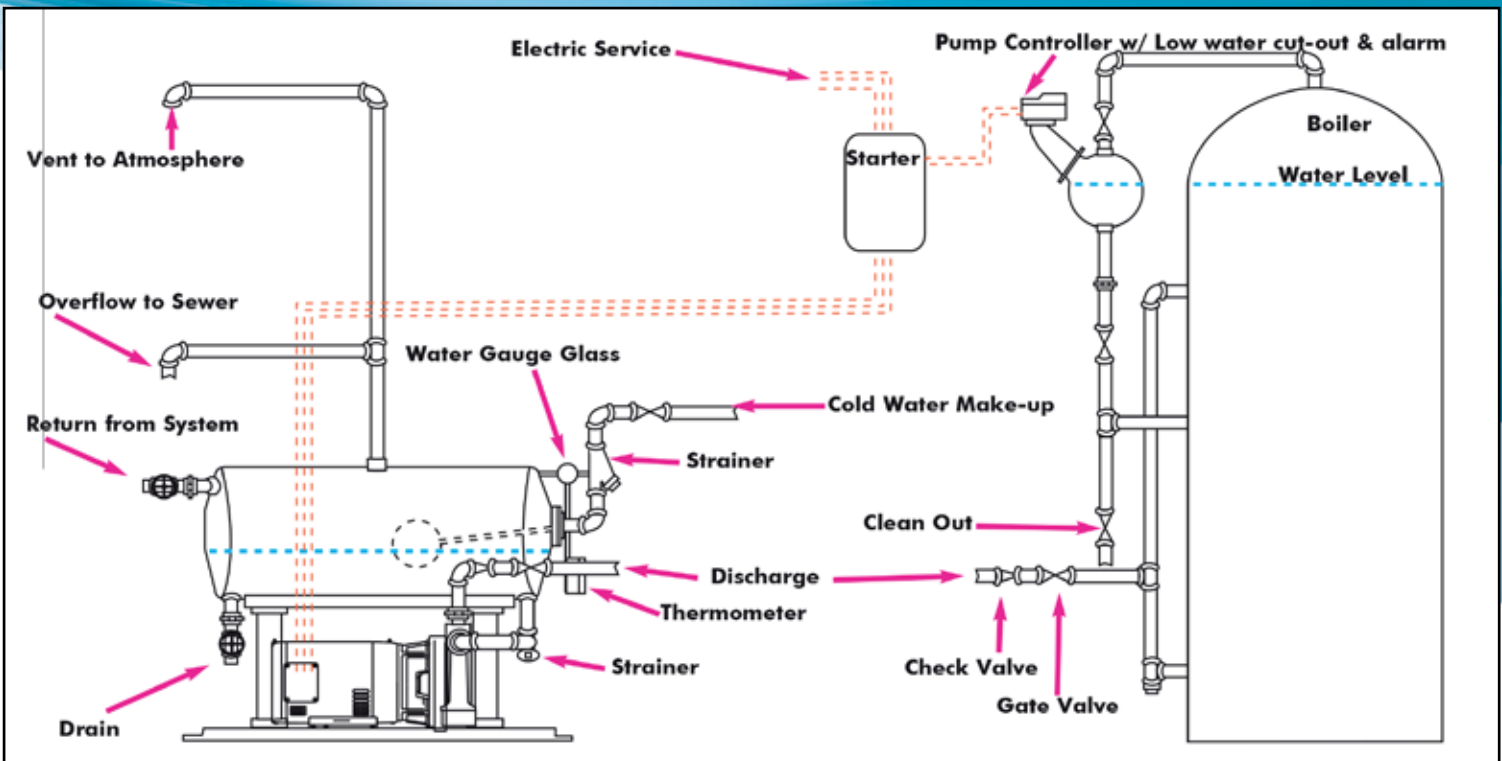
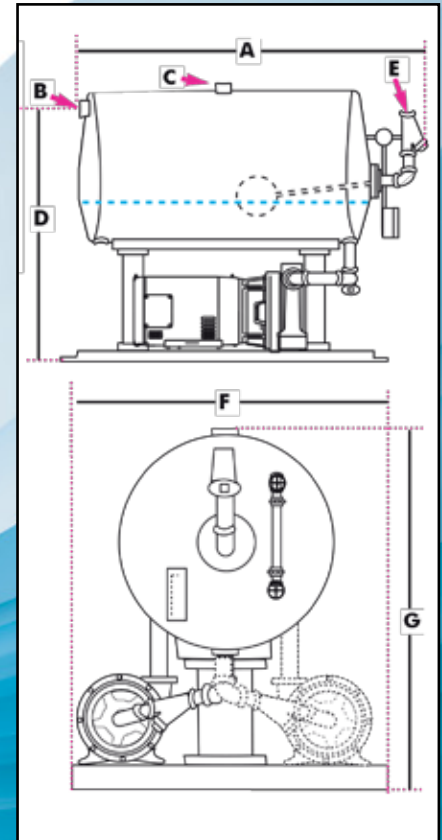



## Boiler Feed Unit Selection Tables (3450 RPM)

IDENTIFICATION: \_\_\_\_\_ Volts / \_\_\_\_\_ Hp / \_\_\_\_\_ Hz

\* USING CLOSED COUPLED SERIES GV6 OR SERIES 1000 PUMPS

SERIES  BFC OR  BFCE 3450 RPM

**MODEL SPECIFICATIONS**

EX: **D** - **CVC** - **1010** - **15**

**S = SIMPLEX**  
**D = DUPLEX**

**UNIT TYPE**  
**CVC = CONDENSATE**  
**BFC = BOILER FEED**  
**BFCE = ELEVATED BOILER FEED**

**RECEIVER SIZES**

**EDR & PSI**  
Ex: E.D.R.=10,000 (10)  
PSI = 10

**ENGINEERING EQUIVALENTS**

1,000 SQ. FT. E.D.R. = 240,000 BTU /HR.  
1,000 SQ. FT. E.D.R. = 247 LBS WATER EVAP. /HR.  
1,000 SQ. FT. E.D.R. = 1/2 GAL WATER EVAP /MIN.

1 SQ. FT. E.D.R. = 240 BTU /HR. (STEAM)  
1 SQ. FT. E.D.R. = 1/4 LBS WATER EVAP. /HR.

1 BOILER HP = 33,475 BTU /HR. (STEAM)  
1 BOILER HP = 34.5 LBS WATER EVAP. /HR. (212°F)  
1 BOILER HP = .069 GAL WATER EVAP. /MIN.  
1 BOILER HP = 140 SQ. FT. E.D.R. (STEAM)  
1 BOILER HP = 222 SQ. FT. E.D.R. (WATER)

1 US GALLON = 231 CU. INCHES

1 LBS = 2.31 FT. OF WATER

Unit Model Number	Boiler Hp	Pump USGPM	Tank Capa. Gallons	Pump Disch Press. PSI	3450 RPM	
	E.D.R (sq. ft)				Motor Hp	Pump Motor Models
<input type="checkbox"/> Simplex <input type="checkbox"/> Duplex						
BFC - 0210				10	1/4	GV6
BFC - 0215	Hp 14	3	15	15	1/3	GV6
BFC - 0220				20	1/2	GV6
BFC - 0230				30	1/2	GV6
BFC - 0240	EDR 2,000	3	15	40	3/4	GV6
BFC - 0250				50	1	GV6
BFC - 0255				55	1 1/2	GV6
BFC - 0270	BTUH 490	3	15	70	--	--
BFC - 0280				80	--	--
BFC - 0290				90	--	--
BFC - 02100				100	--	--
BFC - 0410				10	1/4	GV6
BFC - 0415	Hp 29	6	15	15	1/3	GV6
BFC - 0420				20	1/3	GV6
BFC - 0430				30	1/2	GV6
BFC - 0440	EDR 4,000	6	15	40	3/4	GV6
BFC - 0450				50	1	GV6
BFC - 0455				55	1 1/2	GV6
BFC - 0470	BTUH 990	6	15	70	--	--
BFC - 0480				80	--	--
BFC - 0490				90	--	--
BFC - 04100				100	--	--
BFC - 0610				10	1/3	GV6
BFC - 0615	Hp 43	9	15	15	1/3	GV6
BFC - 0620				20	1/3	GV6
BFC - 0630				30	1/2	GV6
BFC - 0640	EDR 6,000	9	15	40	3/4	GV6
BFC - 0650				50	1	GV6
BFC - 0655				55	1 1/2	GV6
BFC - 0670	BTUH 1,480	9	15	70	--	--
BFC - 0680				80	--	--
BFC - 0690				90	--	--
BFC - 06100				100	--	--
BFC - 0810				10	1/3	GV6
BFC - 0815	Hp 57	12	15	15	1/3	GV6
BFC - 0820				20	1/3	GV6
BFC - 0830				30	3/4	GV6
BFC - 0840	EDR 8,000	12	15	40	1	GV6
BFC - 0850				50	1 1/2	GV6
BFC - 0855				55	1 1/2	GV6
BFC - 0870	BTUH 1,975	12	15	70	--	--
BFC - 0880				80	--	--
BFC - 0890				90	--	--
BFC - 08100				100	--	--

Dimensions not to be used for construction unless prints is certified by factory.

# Boiler Feed Unit Selection Tables (3450 RPM)

IDENTIFICATION: \_\_\_\_\_ Volts / \_\_\_\_\_ Hp / \_\_\_\_\_ Hz

\* USING CLOSED COUPLED SERIES GV6 OR SERIES 1000 PUMPS

SERIES  BFC OR  BFCE 3450 RPM

SERIES  BFC OR  BFCE 3450 RPM

Unit Model Number	Boiler Hp	Pump USGPM	Tank Capa. Gallons	Pump Disch Press. PSI	3450 RPM		Unit Model Number	Boiler Hp	Pump USGPM	Tank Capa. Gallons	Pump Disch Press. PSI	3450 RPM	
					Motor Hp	Pump Motor Models						Motor Hp	Pump Motor Models
E.D.R (sq. ft)	BTUH (1000's)	E.D.R (sq. ft)	BTUH (1000's)										
BFC - 1010	Hp 72 EDR 10,000 BTUH 2,470	15	15	10	1/3	GV6	BFC - 3010	Hp 215 EDR 30,000 BTUH 7,400	45	35	10	--	--
BFC - 1015				15	1/3	GV6	BFC - 3015				15	1/2	GV6
BFC - 1020				20	1/3	GV6	BFC - 3020				20	1/2	GV6
BFC - 1030				30	3/4	GV6	BFC - 3030				30	1	GV6
BFC - 1040				40	3/4	GV6	BFC - 3040				40	1 1/2	GV6
BFC - 1050				50	1 1/2	GV6	BFC - 3050				50	2	GV6
BFC - 1055				55	1 1/2	GV6	BFC - 3055				55	7 1/2	610A
BFC - 1070				70	--	--	BFC - 3070				70	7 1/2	810A
BFC - 1080				80	--	--	BFC - 3080				80	10	810A
BFC - 1090				90	--	--	BFC - 3090				90	10	810A
BFC - 10100	100	--	--	BFC - 30100	100	10	810A						
BFC - 1510	Hp 108 EDR 15,000 BTUH 3,600	22 1/2	25	10	1/3	GV6	BFC - 4010	Hp 285 EDR 40,000 BTUH 9,880	60	50	10	--	--
BFC - 1515				15	1/3	GV6	BFC - 4015				15	--	--
BFC - 1520				20	1/2	GV6	BFC - 4020				20	1	GV6
BFC - 1530				30	3/4	GV6	BFC - 4030				30	1 1/2	GV6
BFC - 1540				40	1	GV6	BFC - 4040				40	2	GV6
BFC - 1550				50	1 1/2	GV6	BFC - 4050				50	2	GV6
BFC - 1555				55	1 1/2	GV6	BFC - 4055				55	7 1/2	610A
BFC - 1570				70	7 1/2	810G	BFC - 4070				70	7 1/2	810A
BFC - 1580				80	10	810G	BFC - 4080				80	10	810A
BFC - 1590				90	20	1020A	BFC - 4090				90	10	810A
BFC - 15100	100	25	1020A	BFC - 40100	100	15	810A						
BFC - 2010	Hp 143 EDR 20,000 BTUH 4,940	30	25	10	1/3	GV6	BFC - 5010	Hp 358 EDR 50,000 BTUH 12,000	75	70	10	--	--
BFC - 2015				15	1/3	GV6	BFC - 5015				15	--	--
BFC - 2020				20	1/2	GV6	BFC - 5020				20	--	--
BFC - 2030				30	3/4	GV6	BFC - 5030				30	3	615J
BFC - 2040				40	1	GV6	BFC - 5040				40	5	610A
BFC - 2050				50	1 1/2	GV6	BFC - 5050				50	5	610A
BFC - 2055				55	2	GV6	BFC - 5055				55	7 1/2	815G
BFC - 2070				70	7 1/2	810A	BFC - 5070				70	7 1/2	810A
BFC - 2080				80	10	810A	BFC - 5080				80	10	810A
BFC - 2090				90	10	810G	BFC - 5090				90	15	810A
BFC - 20100	100	15	810G	BFC - 50100	100	15	810A						
BFC - 2510	Hp 179 EDR 25,000 BTUH 6,170	37 1/2	35	10	1/3	GV6	BFC - 6510	Hp 450 EDR 65,000 BTUH 15,000	97 1/2	70	10	--	--
BFC - 2515				15	1/2	GV6	BFC - 6515				15	--	--
BFC - 2520				20	1/2	GV6	BFC - 6520				20	--	--
BFC - 2530				30	1	GV6	BFC - 6530				30	3	615A
BFC - 2540				40	1 1/2	GV6	BFC - 6540				40	5	615J
BFC - 2550				50	2	GV6	BFC - 6550				50	7 1/2	615J
BFC - 2555				55	2	GV6	BFC - 6555				55	7 1/2	815G
BFC - 2570				70	7 1/2	810A	BFC - 6570				70	10	810A
BFC - 2580				80	7 1/2	810A	BFC - 6580				80	10	810A
BFC - 2590				90	10	810A	BFC - 6590				90	15	810A
BFC - 25100	100	10	810A	BFC - 65100	100	15	810A						

Dimensions not to be used for construction unless prints is certified by factory.





# ● Boiler Feed Unit Selection Tables (1750 RPM)

IDENTIFICATION: \_\_\_\_\_ VOLTS / \_\_\_\_\_ HP / \_\_\_\_\_ HZ

\* USING CLOSED COUPLED SERIES GV6 OR SERIES 1000 PUMPS

SERIES  BFC OR  BFCE 3450 RPM

SERIES  BFC OR  BFCE 1750 RPM

Unit Model Number	Boiler Hp		Pump USGPM	Tank Capa. Gallons	Pump Disch. Press. PSI	3450 RPM	
	E.D.R (sq. ft)	BTUH (1000's)				Motor Hp	Pump Motor Models
	<input type="checkbox"/> Simplex <input type="checkbox"/> Duplex						
BFC - 7510	Hp 538	75,000	112½	70	10	--	--
BFC - 7515					15	--	--
BFC - 7520					20	--	--
BFC - 7530					30	5	615A
BFC - 7540					40	5	615J
BFC - 7550					50	7½	615J
BFC - 7555					55	7½	810A
BFC - 7570					70	10	810A
BFC - 7580					80	10	810A
BFC - 7590					90	15	810A
BFC - 75100	100	15	810A				
BFC - 10010	Hp 717	100,000	150	120	10	--	--
BFC - 10015					15	--	--
BFC - 10020					20	--	--
BFC - 10030					30	5	620A
BFC - 10040					40	7½	615A
BFC - 10050					50	7½	615J
BFC - 10055					55	10	815G
BFC - 10070					70	10	815G
BFC - 10080					80	15	815G
BFC - 10090					90	15	815G
BFC - 100100	100	15	810A				

Unit Model Number	Boiler Hp		Pump USGPM	Tank Capa. Gallons	Pump Disch. Press. PSI	1750 RPM					
	E.D.R (sq. ft)	BTUH (1000's)				Motor Hp	Pump Motor Model				
	<input type="checkbox"/> Simplex <input type="checkbox"/> Duplex										
BFC - 0210	Hp 14	2,000	3	15	10	¼	GV6				
BFC - 0215					15	¼	GV6				
BFC - 0220					20	3	1020A				
BFC - 0230					30	5	1020A				
BFC - 0240					40	7½	1020A				
BFC - 0250	BTUH 490	490	3	15	50	10	1215A				
BFC - 0255					55	10	1215A				
BFC - 0410					Hp 29	4,000	6	15	10	¼	GV6
BFC - 0415									15	⅓	GV6
BFC - 0420									20	3	1020A
BFC - 0430	30	5	1020A								
BFC - 0440	40	7½	1020A								
BFC - 0450	BTUH 990	990	6	15	50	10	1215A				
BFC - 0455					55	10	1215A				
BFC - 0610					Hp 43	6,000	9	15	10	¼	GV6
BFC - 0615									15	¼	GV6
BFC - 0620									20	3	1020A
BFC - 0630	30	5	1020A								
BFC - 0640	40	7½	1020A								
BFC - 0650	BTUH 1,480	1,480	9	15	50	10	1215A				
BFC - 0655					55	10	1215A				
BFC - 0810					Hp 57	8,000	12	15	10	¼	GV6
BFC - 0815									15	¼	GV6
BFC - 0820									20	3	1020A
BFC - 0830	30	5	1020A								
BFC - 0840	40	7½	1020A								
BFC - 0850	BTUH 1,975	1,975	12	15	50	10	1215A				
BFC - 0855					55	10	1215A				
BFC - 1010					Hp 72	10,000	15	15	10	¼	GV6
BFC - 1015									15	¼	GV6
BFC - 1020									20	1½	810A
BFC - 1030	30	5	1020A								
BFC - 1040	40	7½	1020A								
BFC - 1050	BTUH 2,470	2,470	15	15	50	10	1215A				
BFC - 1055					55	10	1215A				

Dimensions not to be used for construction unless prints is certified by factory.

# Boiler Feed Unit Selection Tables (1750 RPM)

IDENTIFICATION: \_\_\_\_\_ Volts / \_\_\_\_\_ Hp / \_\_\_\_\_ Hz

\* USING CLOSED COUPLED SERIES GV6 OR SERIES 1000 PUMPS

SERIES  BFC OR  BFCE 1750 RPM

SERIES  BFC OR  BFCE 1750 RPM

Unit Model Number <input type="checkbox"/> Simplex <input type="checkbox"/> Duplex	Boiler Hp	Pump USGPM	Tank Capa. Gallons	Pump Disch Press. PSI	1750 RPM	
	E.D.R (sq. ft)				Motor Hp	Pump Motor Model
	BTUH (1000's)					
BFC - 1510	Hp 108 EDR 15,000 BTUH 3,600	22 1/2	25	10	1/4	GV6
BFC - 1515				15	1/3	GV6
BFC - 1520				20	1/2	810A
BFC - 1530				30	2	810A
BFC - 1540				40	7/2	1020A
BFC - 1550				50	10	1215A
BFC - 1555				55	10	1215A
BFC - 2010	Hp 143 EDR 20,000 BTUH 4,940	30	25	10	1/4	GV6
BFC - 2015				15	1/3	GV6
BFC - 2020				20	1/2	810A
BFC - 2030				30	2	810A
BFC - 2040				40	7/2	1020A
BFC - 2050				50	10	1215A
BFC - 2055				55	10	1215A
BFC - 2510	Hp 179 EDR 25,000 BTUH 6,170	37 1/2	35	10	1/3	GV6
BFC - 2515				15	1	610A
BFC - 2520				20	1/2	810A
BFC - 2530				30	2	810A
BFC - 2540				40	7/2	1020A
BFC - 2550				50	10	1215A
BFC - 2555				55	10	1215A
BFC - 3010	Hp 215 EDR 30,000 BTUH 7,400	45	35	10	1/2	615J
BFC - 3015				15	3/4	815G
BFC - 3020				20	1 1/2	810A
BFC - 3030				30	2	810A
BFC - 3040				40	5	1020A
BFC - 3050				50	10	1215A
BFC - 3055				55	10	1215A
BFC - 4010	Hp 285 EDR 40,000 BTUH 9,880	60	50	10	3/4	615J
BFC - 4015				15	1	810A
BFC - 4020				20	2	810A
BFC - 4030				30	5	1020A
BFC - 4040				40	7/2	1020A
BFC - 4050				50	10	1215A
BFC - 4055				55	15	1215A

Unit Model Number <input type="checkbox"/> Simplex <input type="checkbox"/> Duplex	Boiler Hp	Pump USGPM	Tank Capa. Gallons	Pump Disch Press. PSI	1750 RPM	
	E.D.R (sq. ft)				Motor Hp	Pump Motor Model
	BTUH (1000's)					
BFC - 5010	Hp 358 EDR 50,000 BTUH 12,000	75	70	10	3/4	615J
BFC - 5015				15	1	815G
BFC - 5020				20	2	810A
BFC - 5030				30	5	810A
BFC - 5040				40	7/2	1020A
BFC - 5050				50	10	1215A
BFC - 5055				55	15	1215A
BFC - 6510	Hp 450 EDR 65,000 BTUH 15,000	97 1/2	70	10	1	615A
BFC - 6515				15	1 1/2	815G
BFC - 6520				20	2	815G
BFC - 6530				30	5	1020A
BFC - 6540				40	7/2	1020A
BFC - 6550				50	10	1215A
BFC - 6555				55	15	1215A
BFC - 6570	70	20	1220A			
BFC - 7510	Hp 538 EDR 75,000 BTUH 18,000	112 1/2	70	10	1 1/2	620A
BFC - 7515				15	2	825A
BFC - 7520				20	3	1020A
BFC - 7530				30	5	1020A
BFC - 7540				40	15	1025A
BFC - 7550				50	10	1215A
BFC - 7555				55	15	1215A
BFC - 7570	70	20	1220A			
BFC - 10010	Hp 717 EDR 100,000 BTUH 24,700	150	120	10	1 1/2	620A
BFC - 10015				15	2	825A
BFC - 10020				20	3	825A
BFC - 10030				30	5	1020A
BFC - 10040				40	15	1025A
BFC - 10050				50	10	1215A
BFC - 10055				55	15	1215A
BFC - 10070	70	20	1220A			

Dimensions not to be used for construction unless prints is certified by factory.



# Condensate Return Unit Series CVC

The condensate pump is operated by a float switch in the condensate tank. As water is returned from the system, it is pumped to the boiler by the condensate pump.

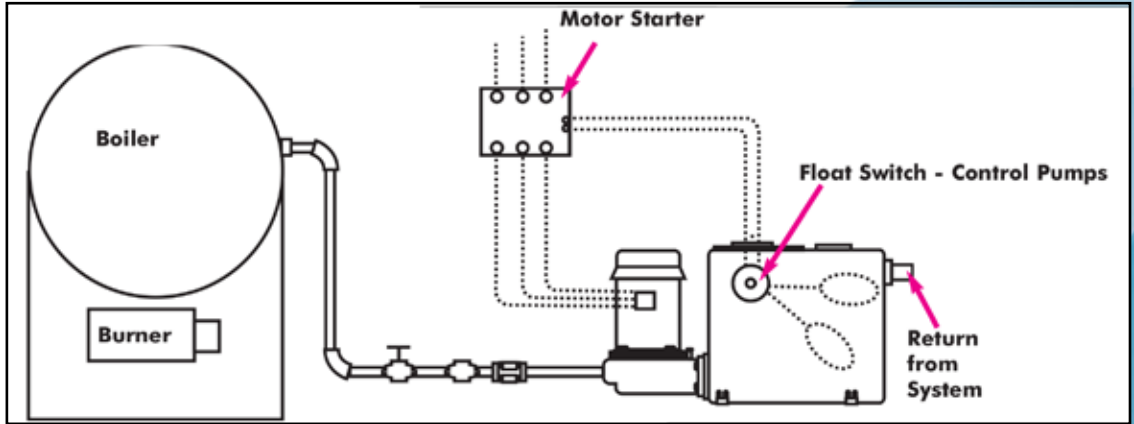

## Boiler Feed Unit Series BFC or BFCE

**Circuit 1** - The boiler level controller operates the condensate pump feeding water to the boiler as required.

**Circuit 2** - The float switch mounted in the condensate tank operates a valve adding water to the condensate tank as required.

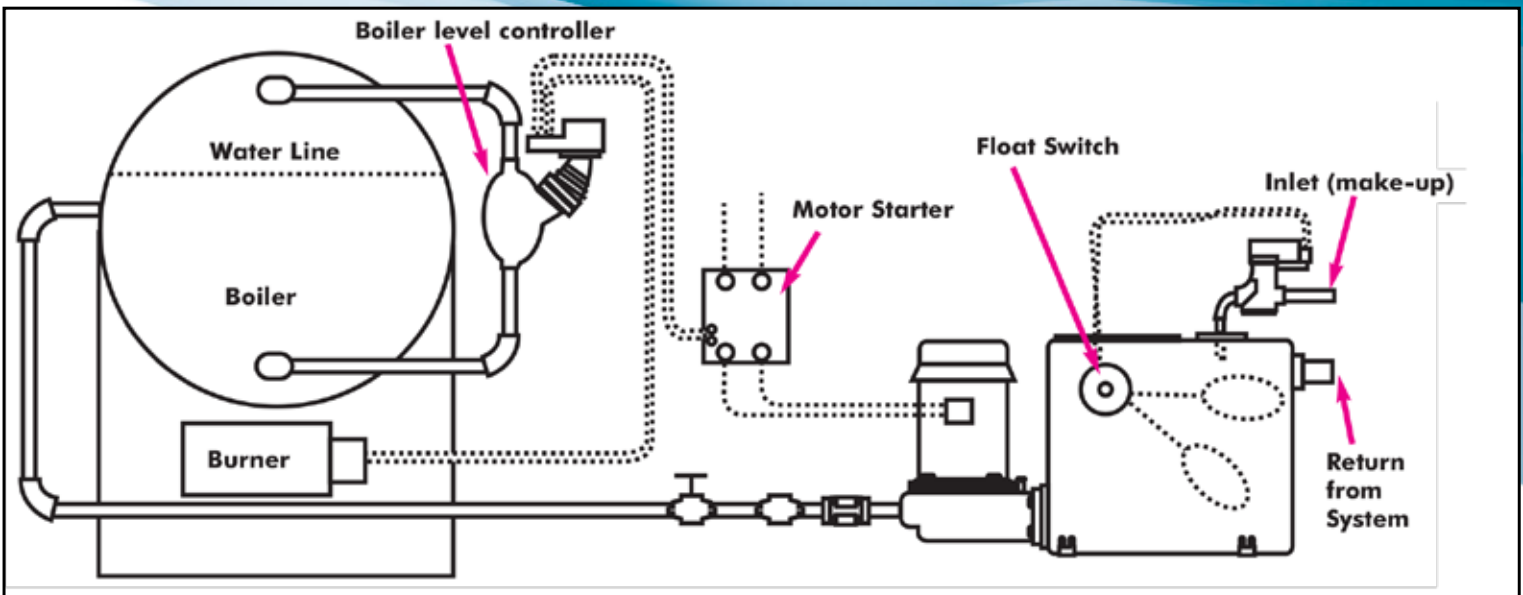
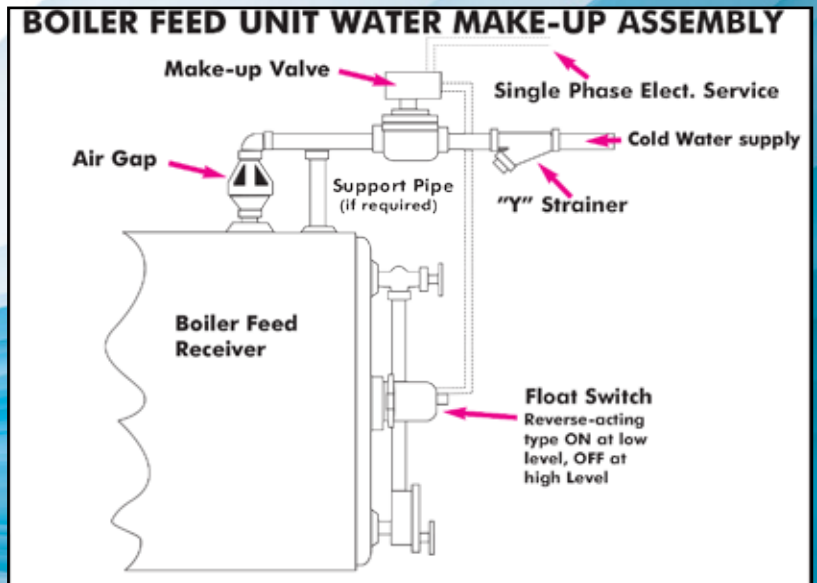





# ● Control Panels

## Series DCP & DCP-B



**SERIES DCP**

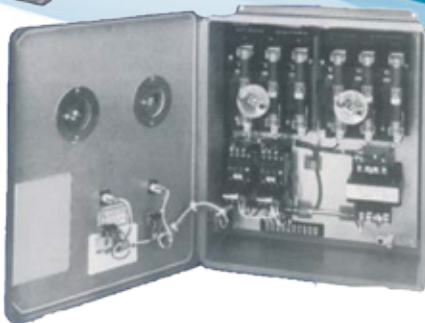
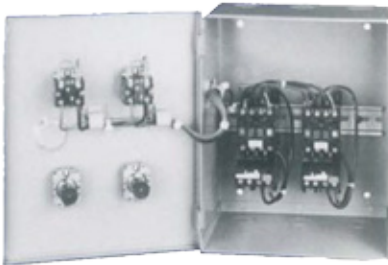

**SERIES DCP-B**

### **SERIES DCP CONTROL PANEL STANDARD**

- 1) NEMA Type 1 only
- 2) 2 starters with 3rd leg overload protection.
- 3) Reset button in the cover.

### **OPTIONAL**

- 3 position selector switch, hand-off auto, Lead-off lag, or test-off auto
- Pilot light(s) 250 V max.
- 1 electric alternator per panel (duplex models only)

### **SERIES DCP-B CONTROL PANEL WITH CIRCUIT BREAKERS STANDARD**

- 1) NEMA Type 1
- 2) 2 starters, each with 3rd leg overload protection and reset button on each starter
- 3) Number terminal strip

### **OPTIONAL**

- NEMA Type, 2, 3, 4X, 7, 9 or 12 Consult Factory
- Fused or non-fused disconnect(s) with interlock with provisions for padlock.
- 1 fuse block per starter
- Fused control circuit transformer 110 volt secondary
- 1 electric alternator per panel (duplex models only)
- Relays - number as required
- Selector switches on cover (1 per starter)
  - Labeled- Hand-off auto
  - Lead-off lag
  - Boiler #1 - off - Boiler #2
  - Pump #1 - off - Pump #2
  - Test-off auto (spring loaded to off)
- Pilot light(s) on cover (1 per starter)
- Alarm bell with silencing switch (1 per panel)
- External reset buttons for starters 1 electric alternator per panel (duplex models only)



## ● **Typical Specifications**

### **CONDENSATE RETURN UNITS SERIES // CVC S-CVC (SIMPLEX) D-CVC (DUPLEX)**

The contractor shall furnish and install a FLO FAB automatic condensate unit. Pump(s) shall be mounted vertically and flanged to the receiver. Pump(s) shall be cast iron bronze fitted end suction centrifugal pumps with 250°F (300°F also available) mechanical seals close coupled to 115/230 Volts single or 208/460/575 Volts three phase 60 Hz, 3500 RPM, open drip-proof or totally enclosed electric motors. A vent line shall be furnished from each pump seal chamber to the receiver.

Receiver shall be 15, 25, 35, 45, 70 or 120 gallons 3/16" black steel or cast iron with 2" vent, 3/4" drain and (2" or 3") inlet.

**Simplex (S-CVC)** unit shall include a UQK-2 float switch assembly.

**Duplex (D-CVC)** unit shall include two UQK-2 float switch with electrical alternator assemblies.

A stem thermometer and a gauge glass should be provided.

**OPTIONAL:** On duplex units, a NEMA 1 control panel with magnetic starter(s) should be installed (not included).

### **BOILER FEED UNITS SERIES // BFC S-BFC (SIMPLEX) D-BFC (DUPLEX)**

The contractor shall furnish and install a FLO FAB automatic ground level boiler feed unit. Pump(s) shall be mounted vertically and flanged to the receiver. Pump(s) shall be cast iron bronze fitted end suction centrifugal pumps with 250°F (300°F also available) mechanical seals close coupled to 115/230 Volts single or 208/460/575 Volts three phase 60 Hz, 3500 RPM, open drip-proof or totally enclosed electric motors.

Receiver shall be 50, 70, 120, 210 or 300 gallons 1/4" black steel with 2" vent, 3/4" drain and (2" or 3") inlet. Simplex (S-BFC) and duplex (D-BFC) unit shall include make-up valve, vent, a stem thermometer and a gauge glass installed on the tank.

### **ELEVATED BOILER FEED UNITS SERIES // BFCE S-BFCE (SIMPLEX) D-BFCE (DUPLEX)**

The contractor shall furnish and install a FLO FAB automatic elevated boiler feed unit. Pump(s) shall be mounted vertically and flanged to the receiver. Pump(s) shall be cast iron bronze fitted end suction centrifugal pumps with 250°F (300°F also available) mechanical seals close coupled to 115/230 Volts single or 208/460/575 Volts three phase 60 Hz, 3500 RPM, open drip-proof or totally enclosed electric motors.

Receiver shall be 50, 70, 120, 210 or 300 gallons 1/4" black steel with 2" vent, 3/4" drain and (2" or 3") inlet. Simplex (S-BFCE) and duplex (D-BFCE) unit shall include make-up valve, vent, a stem thermometer and a gauge glass installed on the tank. Suction isolation butterfly valve(s), inlet «Y» strainer(s), a stem thermometer, a gauge glass and metal flexible will be provided.

### **OPTIONS FOR SERIES CVC - BFC & BFCE**

- «Y» Strainer
- Simplex Basket Strainer (SBS)
- Receivers can be furnished in stainless steel construction.
- 3/4" Solenoid on larger units.
- NEMA 1 control panel with magnetic motor starters with HOA switch shall be furnished for each pump motor mounted and wired on receiver, for remote mounting Nema I enclosures.
- FLO FAB Series DCP Duplex control panel with magnetic starters, HOA switches, with or without circuit breakers 115 volt control circuit transformer, 3rd leg overload protection, terminal strip, Nema I enclosure shall be furnished mounted on receiver & wired, for remote wall mounting Nema I enclosure with or without electric alternator



Submittal Data Sheet Date: \_\_\_\_\_  
Month Day Year

**IDENTIFICATION/TAG:** \_\_\_\_\_

**BILL OF MATERIALS:**

**CONDENSATE RETURN UNITS SERIES CVC AND/OR BOILER FEED UNITS SERIES BFC & BFCE**

**1) PUMP(s)**

A single-stage closed coupled cast iron, bronze fitted casing, leak proof mechanical shaft seal, stainless steel large diameter corrosion resistant shaft, and bronze casing wearing. These pump(s) requirement allows handling of 250 °F condensate without flashing and cavitation. The pump(s) is provided with an axial flow impeller being enclosed in a cast bronze construction. The pump(s) cast iron flanged volute has an internal cast iron baffle preventing pre-rotation of the condensate. The entire rotating assembly can be removed without disturbing the discharge or return piping.

<b>PUMP(s) SELECTION</b>	
<b>CVC MODEL #</b> _____	<b>BFC MODEL #</b> _____
<b>SIMPLEX (S-CVC)</b> <input type="checkbox"/>	<b>SIMPLEX (S-BFC)</b> <input type="checkbox"/>
<b>DUPLEX (D-CVC)</b> <input type="checkbox"/>	<b>SIMPLEX (S-BFCE)</b> <input type="checkbox"/>
	<b>DUPLEX (D-BFCE)</b> <input type="checkbox"/>
	<b>DUPLEX (D-BFC)</b> <input type="checkbox"/>
<b>PUMP CAPACITY:</b> _____ <b>USGPM AT</b> _____ <b>PSI</b>	
<b>1) CENTRIFUGAL PUMP(S)</b> <input type="checkbox"/>	<b>SINGLE STAGE</b> <input type="checkbox"/> <b>MULTI-STAGE</b> <input type="checkbox"/>
<b>2) CLOSED COUPLED</b> <input type="checkbox"/>	

**2) MOTOR(s)**

Open-drip proof motor, standard NEMA construction. Motor bearings are sealed and factory greased for extra-long trouble-free operation. Single phase fractional Hp with dual voltage motors include built-in thermal overload protection. Motors are standard at 3450 RPM.

<b>MOTOR(s) SELECTION</b>	
<b>MOTOR(s) Hp</b> _____	<b>ODP</b> <input type="checkbox"/> <b>TEFC</b> <input type="checkbox"/> <b>XP</b> <input type="checkbox"/>
<b>60Hz SPEED:</b> <b>3450 RPM</b> <input type="checkbox"/> <b>1750 RPM</b> <input type="checkbox"/>	
<b>VOLTAGE:</b> <b>115V</b> <input type="checkbox"/> <b>208V</b> <input type="checkbox"/> <b>230V</b> <input type="checkbox"/> <b>460V</b> <input type="checkbox"/> <b>575V</b> <input type="checkbox"/>	
<b>1 PHASE</b> <input type="checkbox"/> <b>3 PHASE</b> <input type="checkbox"/>	

**3) RECEIVER**

Receiver inlet, pump(s), vent and drain connections.

<b>RECEIVER SELECTION</b>	
<b>CAPACITY</b> _____ <b>GALLONS</b>	<b>TYPE:</b> <b>ASME</b> <input type="checkbox"/> <b>NON-ASME</b> <input type="checkbox"/>
<b>SHAPE:</b> <b>CYLINDRICAL</b> <input type="checkbox"/> <b>RECTANGULAR</b> <input type="checkbox"/>	<b>CONSTRUCTION:</b> <b>STEEL</b> <input type="checkbox"/>
<b>STEEL W/DURATHERM LINING</b> <input type="checkbox"/>	<b>STAINLESS STEEL</b> <input type="checkbox"/>
<b>STEEL W/GALVANIZING</b> <input type="checkbox"/>	<b>CAST IRON (RECTANGULAR ONLY)</b> <input type="checkbox"/>
<b>VENT CONNECTION</b> <input type="checkbox"/>	<b>SIZE:</b> _____ <b>"</b>
<b>BLIND PLATE ON SIMPLEX UNITS FOR FUTURE EXPANSION</b> <input type="checkbox"/>	
<b>SHUT OFF VALVE BETWEEN RECEIVER AND PUMP SUCTION (OPTIONAL)</b> <input type="checkbox"/>	
<b>NON STANDARD RECEIVER</b> <input type="checkbox"/>	<b>SIZE:</b> _____ <b>GALLONS</b>
<b>20 YEARS WARRANTY (OPTIONAL)</b> <input type="checkbox"/>	

<b>CONDENSATE (CVC)</b>	<b>BOILER FEED (BFC OR BFCE)</b>
<b>SELECTION</b>	<b>SELECTION</b>
<input type="checkbox"/> 15 GALLONS	<input type="checkbox"/> 50 GALLONS
<input type="checkbox"/> 25 GALLONS	<input type="checkbox"/> 70 GALLONS
<input type="checkbox"/> 35 GALLONS	<input type="checkbox"/> 120 GALLONS
<input type="checkbox"/> 45 GALLONS	<input type="checkbox"/> 210 GALLONS
<input type="checkbox"/> 70 GALLONS	<input type="checkbox"/> 300 GALLONS
<input type="checkbox"/> 120 GALLONS	





Submittal Data Sheet Date: \_\_\_\_\_  
Month Day Year

**IDENTIFICATION/TAG:** \_\_\_\_\_

**4) RECEIVER ACCESSORIES**

Float switch(es) and alternator connections for complete flexibility

ACCESSORIES SELECTION	
THERMOMETER: RANGE 40°F TO 300°F	<input type="checkbox"/> STRAIGHT <input type="checkbox"/> ANGLE <input type="checkbox"/> DIAL <input type="checkbox"/>
GAUGE GLASS ASSEMBLY	<input type="checkbox"/> (STANDARD EXCEPT: 10 AND 15 GALLONS RECEIVERS)
ADDITIONAL RECEIVER TAPPINGS	<input type="checkbox"/> SIZE: _____"
ONE FLOAT SWITCH (SIMPLEX UNITS)	<input type="checkbox"/> TWO FLOAT SWITCHES (DUPLEX UNITS) <input type="checkbox"/>

**5) MECHANICAL CONTROLS**

**FOR CVC UNITS:**

Automatic operation is provided by an internal mounted enclosed adjustable float switch assembly, for simplex (S-CVC) or two float switches or control panel with electrical alternator for duplex (D-CVC) operation.

The alternator shall: Change the operating sequence automatically after each cycle.

Provide simultaneous operation under peak load conditions

Operate the second pump automatically, should the active pump or its control fail.

SELECTION	
FOR SIMPLEX UNITS: ONE FLOAT SWITCH	<input type="checkbox"/>
FOR DUPLEX UNITS: TWO FLOAT SWITCHES	<input type="checkbox"/>
CONTROL PANEL W/ELECTRICAL ALTERNATOR	<input type="checkbox"/>
NEMA _____ PANEL	<input type="checkbox"/> HIGH LEVEL ALARM WITH FLOAT <input type="checkbox"/>
TANK ALERT MOUNTED	<input type="checkbox"/> UNMOUNTED <input type="checkbox"/> BY OTHERS <input type="checkbox"/>
ISOLATION VALVE(S) (OPTIONAL) IF REQUIRED	<input type="checkbox"/> SIZE: _____"
DISCHARGE PRESSURE GAUGE(S) WITH MINI BALL VALVE(S) (OPTIONAL)	<input type="checkbox"/>
INLET STRAINER FOR TANK RETURN CONNECTION (LOOSE)	<input type="checkbox"/> SIZE: _____"
INLET BASKET STRAINER (CAST IRON RECEIVER)	<input type="checkbox"/> SIZE: _____"

**FOR BFC OR BFCE UNITS:**

Automatic operation is provided by an internal mounted enclosed adjustable float switch operated by an internal make-up valve for boiler feed units.

SELECTION	
FOR SIMPLEX UNITS: ONE FLOAT SWITCH	<input type="checkbox"/>
FOR DUPLEX UNITS: TWO FLOAT SWITCHES	<input type="checkbox"/>
OR CONTROL PANEL W/ELECTRICAL ALTERNATOR	<input type="checkbox"/>
NEMA _____ PANEL	<input type="checkbox"/> HIGH LEVEL ALARM WITH FLOAT <input type="checkbox"/>
TANK ALERT MOUNTED	<input type="checkbox"/> UNMOUNTED <input type="checkbox"/> BY OTHERS <input type="checkbox"/>
ISOLATION VALVE(S) (OPTIONAL) IF REQUIRED	<input type="checkbox"/> SIZE: _____"
DISCHARGE PRESSURE GAUGE(S) WITH MINI BALL VALVE(S) (OPTIONAL)	<input type="checkbox"/>
PRESSURE GAUGE(S): DRY	<input type="checkbox"/> LIQUID FILLED <input type="checkbox"/>
INLET STRAINER FOR TANK RETURN CONNECTION (LOOSE)	<input type="checkbox"/> SIZE: _____"
INLET Y STRAINER	<input type="checkbox"/> SIZE: _____"
INLET BASKET STRAINER	<input type="checkbox"/> SIZE: _____"
FLOAT OPERATED INTERNAL MAKE-UP VALVE	<input type="checkbox"/>
GAUGE GLASS AND SHUT-OFF VALVES	<input type="checkbox"/> (ON BFC 15 TO 200 GALLONS RECEIVERS)

**6) ELECTRICAL CONTROLS**

See EP panel for proper selection. All panels are CSA and/or UL approved.



We are proud supplier for the following completed and on going projects :



**Las Positas College**  
3000 Campus Hill Dr,  
Livermore, CA, USA  
94551



**The West Mall**  
25 The West Mall,  
Toronto, ON  
M9C 1B8



**Baliscus**  
1075 Grand Héron Boul.,  
Saint-Jérôme, QC, CA  
J5L 1G2



**Montréal - P.E.T  
International Airport,**  
975 boul. Roméo-Vachon  
Dorval, Quebec, H4Y 1H1

## Sales and Service:

Quebec, Canada  
Tel. : (450) 621-2995  
Fax : (450) 621-4995

Lake Worth  
Florida, USA  
33467-5749

Toronto, Canada  
Tel. : +1 (647) 544-2995

[www.flofab.com](http://www.flofab.com)

SERVICE 24/7 : [parts@flofab.com](mailto:parts@flofab.com)

