

PARTS LIST		
ITEM	QTY	DESCRIPTION
5	2	WAFER CHECK VALVES 3"
7	4	BUTTERFLY VALVE 3"
10	2	P1P2
12	2	Y-STRAINER 3" #150
15	2	LOW WATER CUT-OFF
16	4	THERMOMETER 9"
17	6	BALL VALVE 1/4"
18	4	PRESSURE GAUGE - 0-200PSI
19	2	PRESSURE GAUGE - 0-60PSI
22	2	FLOW SWITCH
23	2	PRESSURE RELIEF VALVE
24	1	SKID
42	3	STAINLESS STEEL FLEXIBLE CONNECTOR 4"
43	4	2.50" VICTAULIC RIGID COUPLING
45	2	NEUTRALIZER
51	4	SPRING SYSTEM

NOTE:

- PIPING MATERIAL, STEEL SCHEDULE 40

DRAWING %	
FABRICATION	
100%	
90%	
75%	X
50%	
PRELIMINARY	

REVISION HISTORY		
REV	DESCRIPTION	DATE
1	PRELIMINARY DRAWING	10/08/2015
2	ADDING NEUTRALISER & EXTRA PIPE	10/09/2015
3	CHANGING PIPING HEIGHT	10/27/2015
4	CHANGING PIPE ORIENTATION	10/28/2015
5	CHANGE PIPING HEIGHT & ADD CAP ON DISCHARGE HEADER	11/19/2015

THIS DRAWING MUST BE SENT WITH PURCHASE ORDER

DESIGNER D.GERMAIN	DATE 11/19/2015	TITLE / TITRE 104 440_DUPLEX BOILER
 860 BOULEVARD INDUSTRIEL BOIS-DES-FILION, QC J6Z 4V7 (CANADA) (450) 621-2995 WWW.FLOFAB.COM		PROJECT / PROJET GLOUCESTOR SHCOOL
		CUSTOMER / CLIENT APPLIED HEAT TRANSFER
QUOTE 104 440	DWG NO 104 440_DUPLEX BOILER	REV 5
SCALE / ECHELLE 1:14	TAG D-BOILER	SHEET 1 OF 3

PARTS LIST

ITEM	QTY	DESCRIPTION
1	2	BOILER DYNA FORCE 1400
5	2	WAFER CHECK VALVES 3"
7	4	BUTTERFLY VALVE 3"
10	2	P1P2
12	2	Y-STRAINER 3" #150
15	2	LOW WATER CUT-OFF
16	4	THERMOMETER 9"
17	6	BALL VALVE 1/4"
18	4	PRESSURE GAUGE - 0-200PSI
19	2	PRESSURE GAUGE - 0-60PSI
22	2	FLOW SWITCH
23	2	PRESSURE RELIEF VALVE
24	1	SKID
42	3	STAINLESS STEEL FLEXIBLE CONNECTOR 4"
43	4	2.50" VICTAULIC RIGID COUPLING
45	2	NEUTRALIZER
48	1	EXTRA PIPE
51	4	SPRING SYSTEM

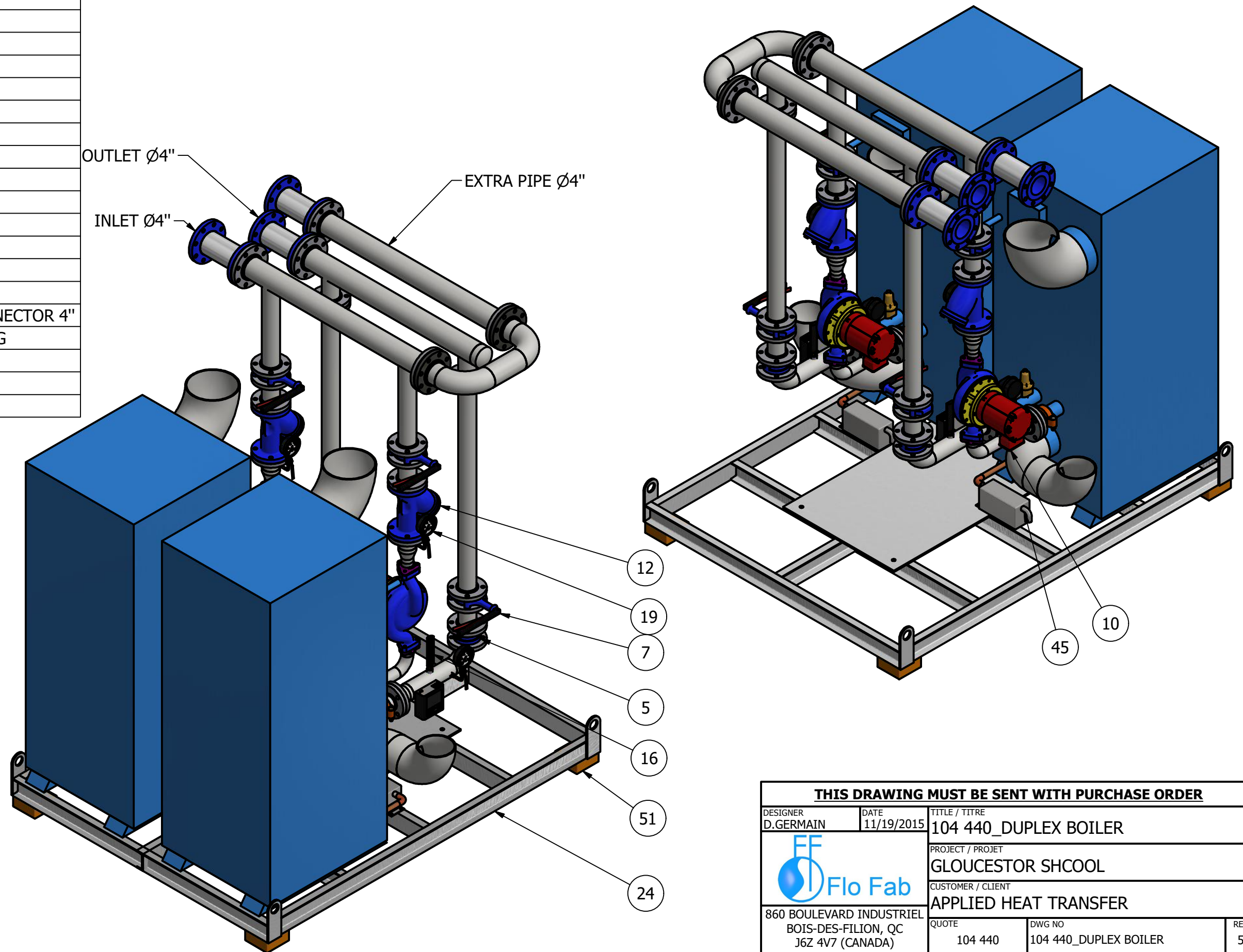

THIS DRAWING MUST BE SENT WITH PURCHASE ORDER			
DESIGNER D.GERMAIN	DATE 11/19/2015	TITLE / TITRE 104 440_DUPLEX BOILER	
 860 BOULEVARD INDUSTRIEL BOIS-DES-FILION, QC J6Z 4V7 (CANADA) (450) 621-2995 WWW.FLOFAB.COM		PROJECT / PROJET GLOUCESTOR SHCOOL	CUSTOMER / CLIENT APPLIED HEAT TRANSFER
		QUOTE 104 440	DWG NO 104 440_DUPLEX BOILER
SCALE / ECHELLE 1:19	TAG D-BOILER	SHEET 2 OF 3	

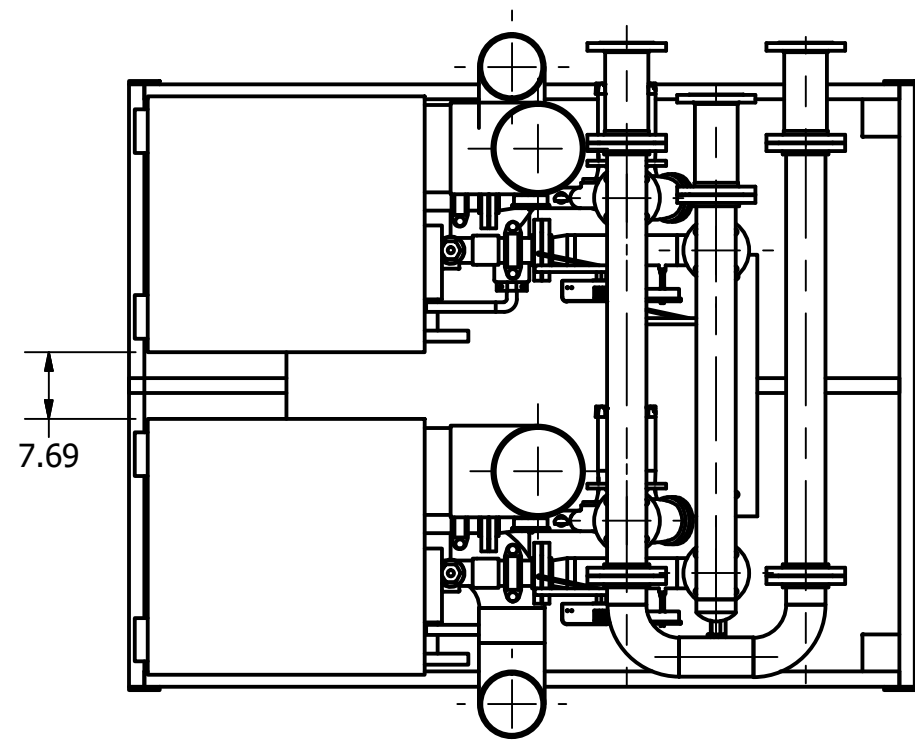
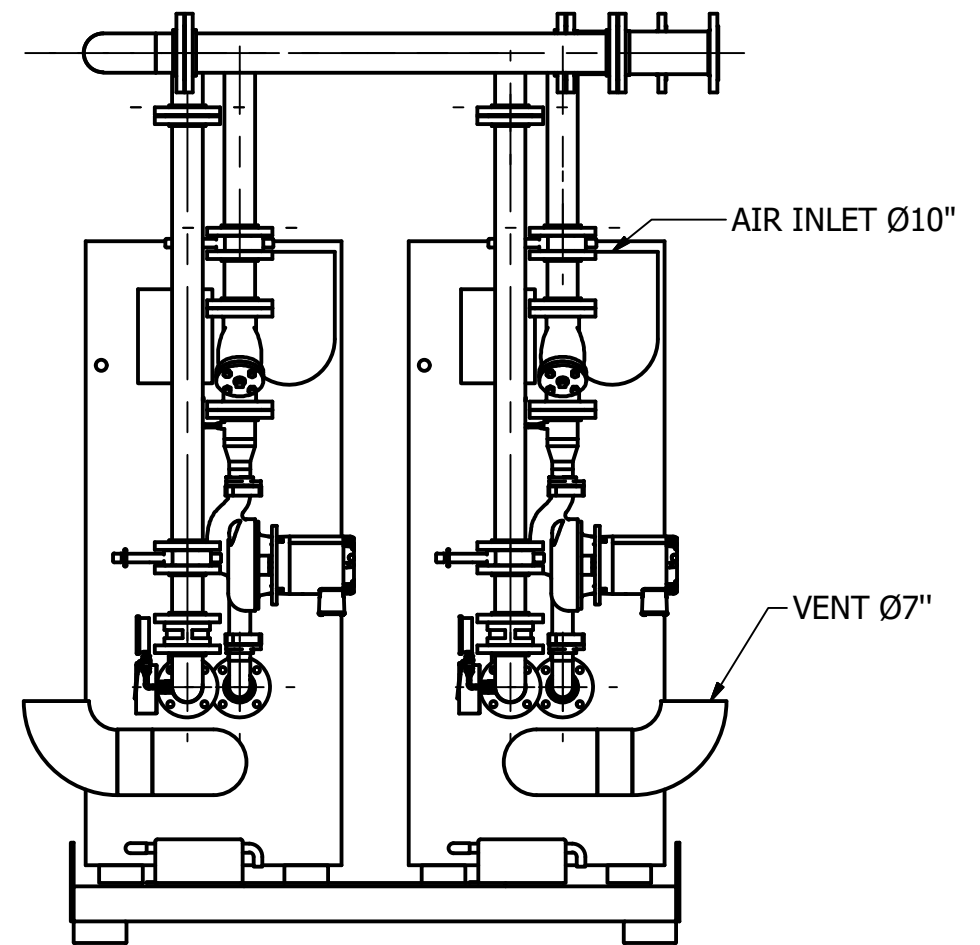
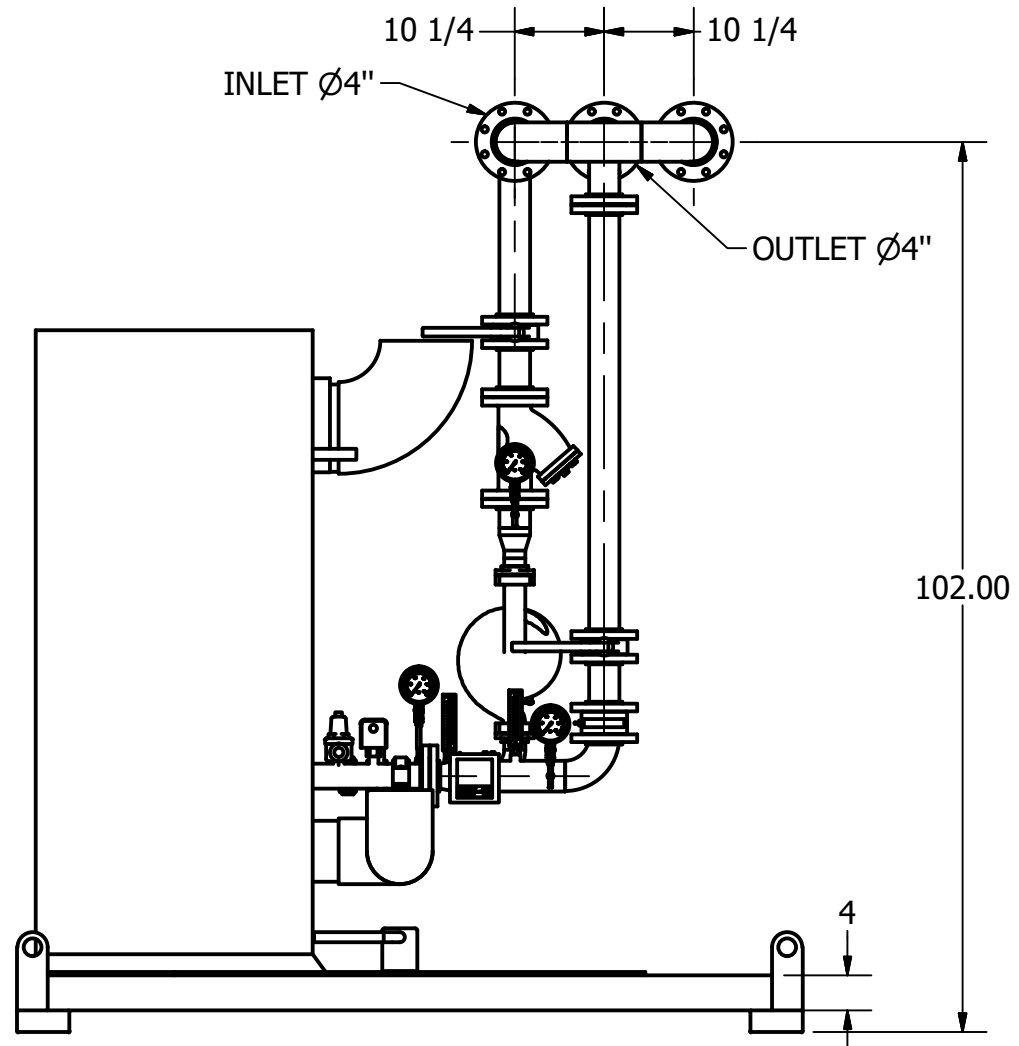

THIS DRAWING MUST BE SENT WITH PURCHASE ORDER				
DESIGNER D.GERMAIN	DATE 11/19/2015	TITLE / TITRE 104 440_DUPLEX BOILER		
		PROJECT / PROJET GLOUCESTOR SHCOOL		
		CUSTOMER / CLIENT APPLIED HEAT TRANSFER		
860 BOULEVARD INDUSTRIEL BOIS-DES-FILION, QC J6Z 4V7 (CANADA) (450) 621-2995 WWW.FLOFAB.COM		QUOTE 104 440	DWG NO 104 440_DUPLEX BOILER	REV 5
		SCALE / ECHELLE 1:22	TAG D_BOILER	SHEET 3 OF 3