



# WHERE QUALITY COMES FIRST

## cal-pro

### hydronic expansion tanks



*Side connection allows for quicker, less expensive installation*

#### technical features:

- 
- 
- *Each tank is factory leak tested to ensure tank integrity*
- *Certified synthetic SBR rubber diaphragm*
- *All diaphragms designed to maximize drawdown*
- *MIG welding eliminates interior rough spots and sharp edges*
- *Welded side outlet allows easy and quick installation*
- *Low profile tank design with full membrane depth eliminates stretching of diaphragm, providing increased life cycle*
- *External baked on epoxy-polyester coating provides a durable, appliance like finish*
- *Protected pre charge valve eliminates potential leak path*
- *5 year warranty on all models*

#### material description

description	material
shell	carbon steel
connections	carbon steel
membrane	SBR synthetic rubber
color	grey

#### operating conditions

max. working pressure 2-13.2 gal	60 psi
max. working pressure 21-184 gal	90 psi
max. operating temperature	210°F
factory precharge	12 psi



## technical drawings

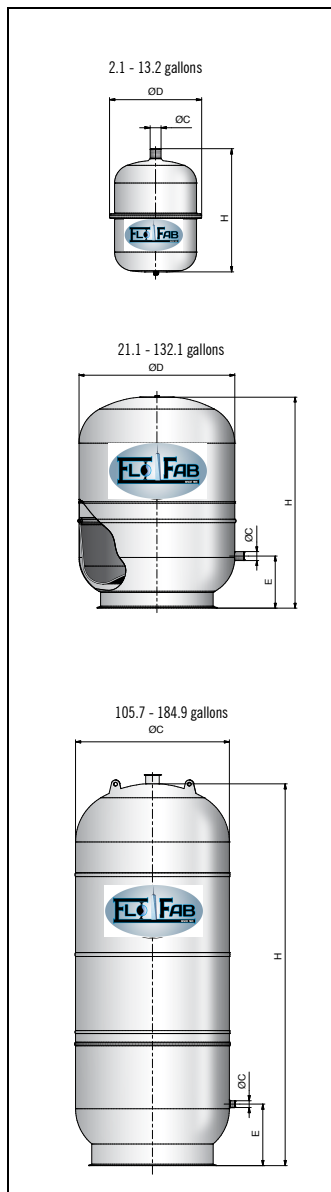

## technical and dimensional data

	Model #	Capacity	Diameter	Height	Connection height	Connection	Acceptance Volumes
		Gallons	inches (ØD)	inches (H)	inches (E)	(ØC)	
Inline	ZHT8	2.1	8.7	11.6	-	1/2" NPT	1.4
	ZHT12	3.2	11.6	11.1	-	1/2" NPT	2
	ZHT18	4.8	11.4	14.8	-	1/2" NPT	3
	ZHT24	6.3	12.8	16.3	-	1/2" NPT	3.9
	ZHT35	9.2	15.9	16.1	-	3/4" NPT	5.7
	ZHT50	13.2	16.0	20.9	-	3/4" NPT	8.1
	ZHT35F	9.2	15.9	15.2	4.7	3/4" NPT	5.7
	ZHT50F	13.2	16.0	20.0	6.2	3/4" NPT	8.1
With Base	ZHT 80	21.1	17.7	23.9	5.9	3/4" NPT	15.3
	ZHT105	27.7	19.7	26.2	6.5	3/4" NPT	20.1
	ZHT150	39.6	19.7	35.3	8.5	3/4" NPT	28.8
	ZHT200	52.8	23.6	32.0	8.9	3/4" NPT	38.4
	ZHT250	66.0	24.8	37.0	9.6	3/4" NPT	48
	ZHT300	79.3	24.8	43.5	9.6	3/4" NPT	57.7
	ZHT400	105.7	24.8	57.1	9.6	3/4" NPT	76.8
	ZHT500	132.1	29.5	52.8	11.4	1" NPT	96
	ZHT600	158.5	29.5	61.2	11.4	1" NPT	115.2
	ZHT700	184.9	29.5	69.1	11.4	1" NPT	134.2

## cal pro sizing chart

Boiler Net Output (1000's of BTU/Hr)	Type of Radiation			
	Finned Tube Baseboard and Radiant	Convection and Unit Heaters	Radiators	Cast Iron Baseboard
25	ZHT8	ZHT8	ZHT8	ZHT8
50	ZHT8	ZHT8	ZHT18	ZHT18
75	ZHT18	ZHT18	ZHT18	ZHT24
100	ZHT18	ZHT18	ZHT24	ZHT24
125	ZHT18	ZHT24	ZHT24	ZHT24
150	ZHT18	ZHT24	ZHT50	ZHT50
175	ZHT24	ZHT24	ZHT50F	ZHT50F
200	ZHT24	ZHT24	ZHT50F	ZHT50F
250	ZHT24	ZHT50	ZHT50F	ZHT80
300	ZHT50	ZHT50F	ZHT50F	ZHT80
350	ZHT50F	ZHT50F	ZHT80	ZHT105
400	ZHT50F	ZHT80	ZHT80	ZHT105
500	ZHT80	ZHT105	ZHT105	ZHT150

## assembly diagram

