

Manufacturier de POMPES, ÉCHANGEURS, RÉSERVOIRS et ACCESSOIRES HVAC.
Centre de SERVICE après vente et atelier de RÉPARATION.

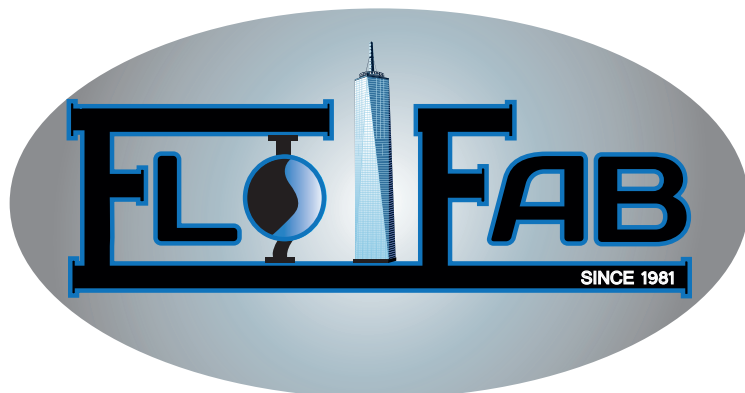

Réservoirs ASME et NON-ASME

Séries R & S

Séries 2000

Séries AS

Séries ADSR

Séries ADSF

Séries SEP

Séries HTS-HTL

Séries BT

Séries RDT

Séries RDB

Séries PBT

Séries HDT

Séries HDB

Séries HB

Séries CUS



www.flofab.com

001-cat-2017-rés

TABLE OF CONTENT

RÉSERVOIRS NON-ASME.....	3-7
SÉRIE R1000/S3000/R4000/R5000/R6000.....	4
SÉRIE 2000.....	5
SÉRIE AS.....	6
RÉSERVOIRS ASME.....	7-25
SÉRIE SEP.....	7-8
SÉRIE ADSF.....	9-10
SÉRIE ADSR.....	11-12
PERFORMANCES CURVES.....	13-15
SÉRIE HTS-HTL.....	17
SÉRIE BT.....	18
SÉRIE RDT.....	19
SÉRIE RDB.....	20
SÉRIE PBT.....	21
SÉRIE HDT.....	22
SÉRIE HDB.....	23
SÉRIE HB.....	24
SÉRIE CUS.....	25
DÉTAILS D'INSTALLATION.....	26

HISTOIRE

Flo Fab a été créé en 1981 par Denis Gauvreau, qui a maintenant 35 années d'expérience dans ce domaine. Le principal objectif de la société était de servir en tant que distributeur de plusieurs pompes différentes et d'accessoires HVAC pour fabricants. Cependant, Flo Fab s'est progressivement dissocié de ces fabricants afin d'offrir sa propre ligne de produits pour les entrepreneurs en plomberie et chauffage.

La gamme de produits Flo Fab a été créé et développé par Denis Gauvreau et constamment perfectionné par Marc Gauvreau, Michelle Gauvreau ainsi que par une équipe d'ingénieurs et de dessinateurs. Les produits Flo Fab sont une combinaison de plusieurs modèles existants, de produits renommés et de nombreuses idées novatrices de quelques professionnels de nouvelle génération.

Au fil des ans, Flo Fab a acquis plusieurs sociétés, dont trois centres de service: MÉNARD, LÉONARD ÉLECTRIQUE et PMA. Cependant, AQUAPROFAB, une autre société achetée en 1999 par Flo Fab, a conservé son identité d'origine puisque les documents lui permettant de fabriquer des appareils à pression selon le code ASME avait déjà été enregistrée sous ce nom. En outre, en Mars 2001, Flo Fab a acheté de l'équipement, des dessins de fabrication et des schémas de IDEALCO, un fabricant de coquille et échangeurs de chaleur à tubes.

Le départements du service, des réparations, des ventes, de l'ingénierie, de la conception, de la production, du contrôle de la qualité, de la comptabilité et de l'administration de toutes les sociétés ci-dessus sont désormais regroupés dans le même lieu. Cela a permis à Flo Fab de conserver le personnel compétent et expérimenté de professionnels ayant des capacités variées et spécialisées qui travaillent en permanence sur l'amélioration de nos produits existants et futurs.

Flo Fab a grandi très rapidement et se compose désormais d'une large gamme de produits disponibles directement à partir du fabricant. Cela comprend les pompes et les forfaits de pompage, réservoirs, échangeurs de chaleur et accessoires hydrauliques. Ceci permet à l'entrepreneur en plomberie et chauffage de profiter des économies sans compromettre la qualité des produits.



● Réservoirs NON-ASME Tanks

Série R1000 Series

Fixed bladder tank with
top system connection
Réservoir à vessie fixe
avec raccord à la partie supérieure

Série R2000 Series

Replaceable bladder tank with
top system connection
Réservoir à vessie remplaçable
avec raccord à la partie supérieure

Série S3000 Series

Replaceable bladder tank with
bottom system connection
Réservoir à vessie remplaçable
avec raccord à la partie inférieure

Série R4000 Series

Replaceable bladder tank with
top system connection
Réservoir à vessie remplaçable
avec raccord à la partie supérieure

Série R5000 Series

Replaceable bladder tank with
top system connection
Réservoir à vessie remplaçable
avec raccord à la partie supérieure

Série R6000 Series

Replaceable bladder tank with
top system connection
Réservoir à vessie remplaçable
avec raccord à la partie supérieure

MODEL	DIAMETER (INCHES)	HEIGHT (INCHES)	CAPACITY		SYSTEM DRAWDOWN 30/50 (GAL.)	PRECHARGE	CONNECTION
			(GAL.)	(LITERS)			
R2080-671V	17.72	23.94	21,13	80.00	7.05	29 PSI / 2 BAR	1" NPT
R2100-771V	19.69	26.18	27,74	105.00	9.25	29 PSI / 2 BAR	1-¼" NPT
R2150-771V	19.69	35.31	39,63	150.00	13.21	29 PSI / 2 BAR	1-¼" NPT
R2250-571V	24.80	37.68	66,04	250.00	22.02	29 PSI / 2 BAR	1-¼" NPT
R6300-S6669	24.80	57.09	105,67	400.00	35.23	29 PSI / 2 BAR	1-¼" NPT
R6500-S6669	29.53	61.22	158.50	600.00	52.84	29 PSI / 2 BAR	1-¼" NPT

NOTES: MAXIMUM OPERATING PRESSURE 150 PSI - MAXIMUM OPERATING TEMPERATURE 200°F

CONSTRUCTION BENEFITS

Protected precharge valve.

Durable steel tank. Deep-drawn steel shell for extra strength. Welding process (MIG) eliminates interior rough spots and sharp edges and prevents damage to diaphragm and liner.

Pre - pressurized air chamber

Butyl diaphragm, isolates water from air.

Exclusive inside epoxy coating: no corrosion.

External epoxy-polyester coating: no rusting.

Mild steel connction
Stainless Steel Connexion on request.

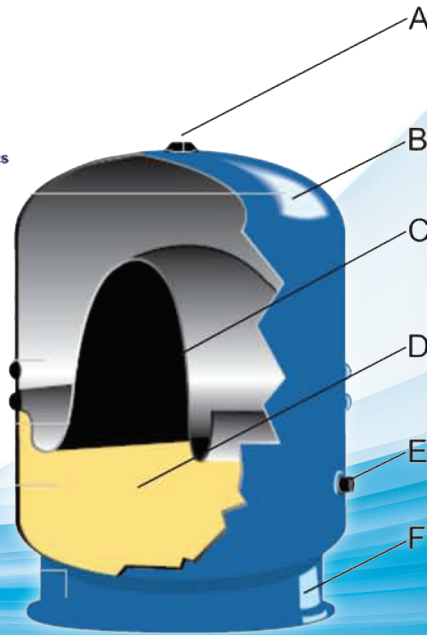

A) PROTECTED PRECHARGE VALVE BRAZED TO PREVENT AIR LOSS.

B) DEEP DRAWN HEAVY GAUGE STEEL, WITH FEWER WELDS.

C) WELDED-IN ACCEPTANCE FITTING IS HIGH OFF THE FLOOR FOR EASIER AND SAFER INSTALLATION.

D) LOWER PROFILE BASE SAVES SPACE.

E) BAKED ON PLASTIC COATING TO STOP CORROSION AND GIVE APPLIANCE LIKE APPEARANCE.

F) CHLORO BUTYL DIAPHRAGM ISOLATES WATER FROM AIR.

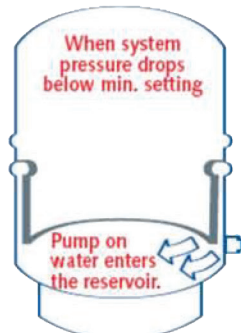



RÉSERVOIRS NON-ASME TANKS

MODEL	DIAMETER (INCHES)	HEIGHT (INCHES)	CAPACITY		SYSTEM DRAWDOWN 30/50 (GAL.)	PRECHARGE	CONNECTION
			(GAL.)	(LITERS)			
2080	17.72	23.94	21,13	80.00	7.05	29 PSI / 2 BAR	1" NPT
2100	19.69	26.18	27,74	105.00	9.25	29 PSI / 2 BAR	1-¼" NPT
2150	19.69	35.31	39,63	150.00	13.21	29 PSI / 2 BAR	1-¼" NPT
2250	24.80	37.68	66,04	250.00	22.02	29 PSI / 2 BAR	1-¼" NPT
2300	24.80	57.09	105,67	400.00	35.23	29 PSI / 2 BAR	1-¼" NPT
2500	29.53	61.22	158.50	600.00	52.84	29 PSI / 2 BAR	1-¼" NPT

NOTES: MAXIMUM OPERATING PRESSURE 150 PSI - MAXIMUM OPERATING TEMPERATURE 200°F

- Protected precharge valve.
- Durable steel tank. Deep-drawn steel sheel for extra strenght. Welding process (MIG) eliminates interior rough spots and sharp edges and prevents damage to diaphragm and liner.
- Pre - pressurized air chamber
- Butyl diaphragm, isolates water from air.
- Exclusive inside epoxy coating: no corrosion.
- External epoxy-polyester coating: no rusting.
- Mild steel connetion
Stainless Steel Connexion on request.

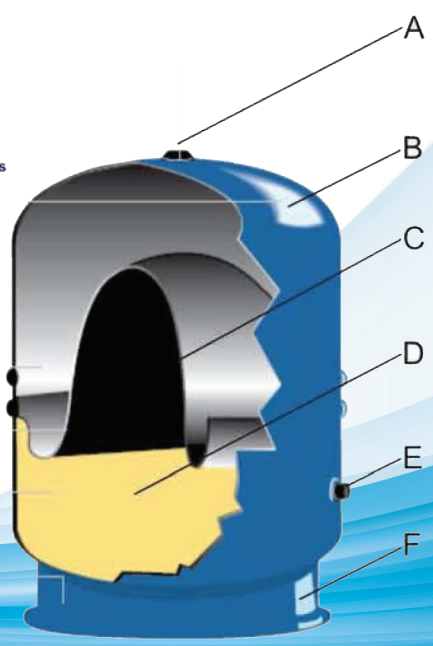

CONSTRUCTION BENEFITS

- A) PROTECTED PRECHARGE VALVE BRAZED TO PREVENT AIR LOSS.
- B) DEEP DRAWN HEAVY GAUGE STEEL, WITH FEWER WELDS.
- C) WELDED-IN ACCEPTANCE FITTING IS HIGH OFF THE FLOOR FOR EASIER AND SAFER INSTALLATION.
- D) LOWER PROFILE BASE SAVES SPACE.
- E) BAKED ON PLASTIC COATING TO STOP CORROSION AND GIVE APPLIANCE LIKE APPEARANCE.
- F) CHLORO BUTYL DIAPHRAGM ISO-LATES WATER FROM AIR.

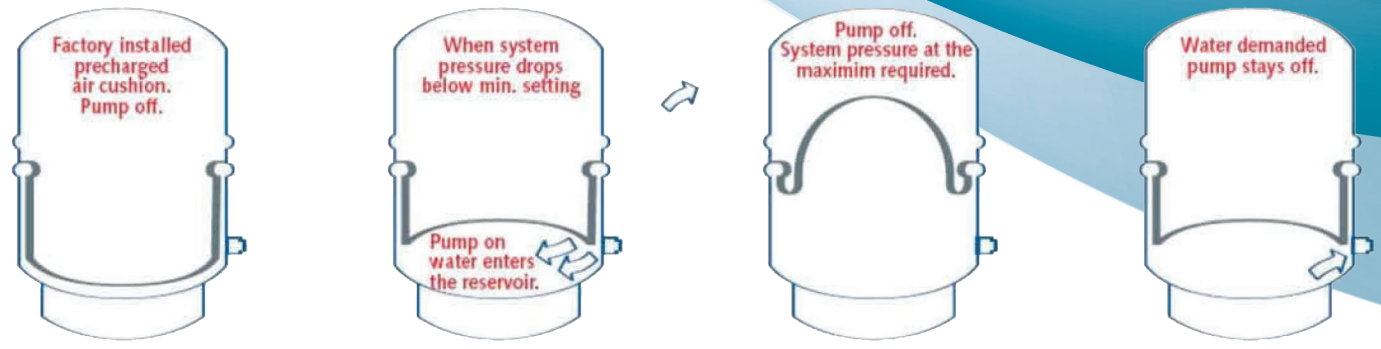

• Air Scoop Série AS

FEATURES :

- Available in heavy cast iron construction in sizes from 1" (25mm) to 3" (80mm). 4" (100mm) is welded steel construction.
- Taps are provided for expansion tank and air vent connection.
- Maximum working pressure of 125 PSI (862 Kpa)
- Maximum operating temperature of 275°F (146°C)

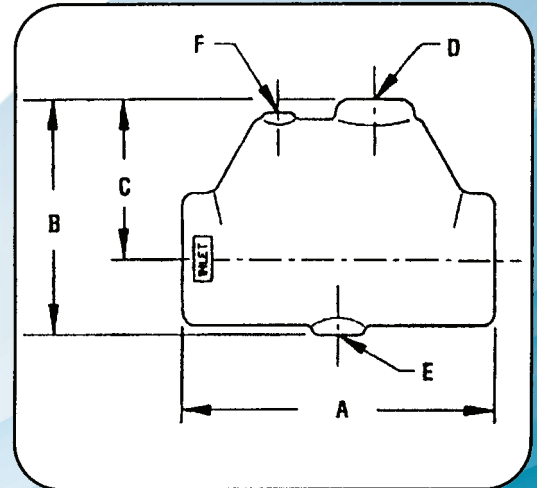

DIMENSIONAL DATA :

FLO/FAB MODEL NUMBER	DIAMETER		DIMENSIONS										WEIGHT			
	IN	MM	A		B		C		D		E		F		Lbs	kg
			IN	MM	IN	MM	IN	MM	IN	MM	IN	MM	IN	MM		
AS0100	1	25	6	150	4	100	2-1/2	65	*	*	1/2 NPT	15 NPT	1/8 NPT	3 NPT	4	1.8
AS0125	1-1/4	32	6	150	4	100	2-1/2	65	*	*	1/2 NPT	15 NPT	1/8 NPT	3 NPT	4	1.8
AS0150	1-1/2	40	8	200	6	150	4	100	3/4 NPT	20 NPT	1/2 NPT	15 NPT	1/8 NPT	3 NPT	7	3.2
AS0200	2	50	8	200	6	150	4	100	1 NPT	25 NPT	1/2 NPT	15 NPT	1/8 NPT	3 NPT	7	3.2
AS0250	2-1/2	65	10	250	8	200	5-1/2	140	1 NPT	25 NPT	1/2 NPT	15 NPT	1/8 NPT	3 NPT	15	6.8
AS0300	3	80	10	250	8	200	5-1/2	140	1-1/4 NPT	32 NPT	1/2 NPT	15 NPT	1/8 NPT	3 NPT	14	6.4
AS0400	4	100	16-3/16	405	11-3/8	284	7-1/8	178	1-1/2 NPT	40 NPT	1/2 NPT	15 NPT	1/4 NPT	7 NPT	52	23.6

*No conventional expansion tank tapping.

Dimension are subject to change without notice.

VORTEX TYPE AIR SEPARATOR WITH FLANGE CONNECTION SERIES "SEP"

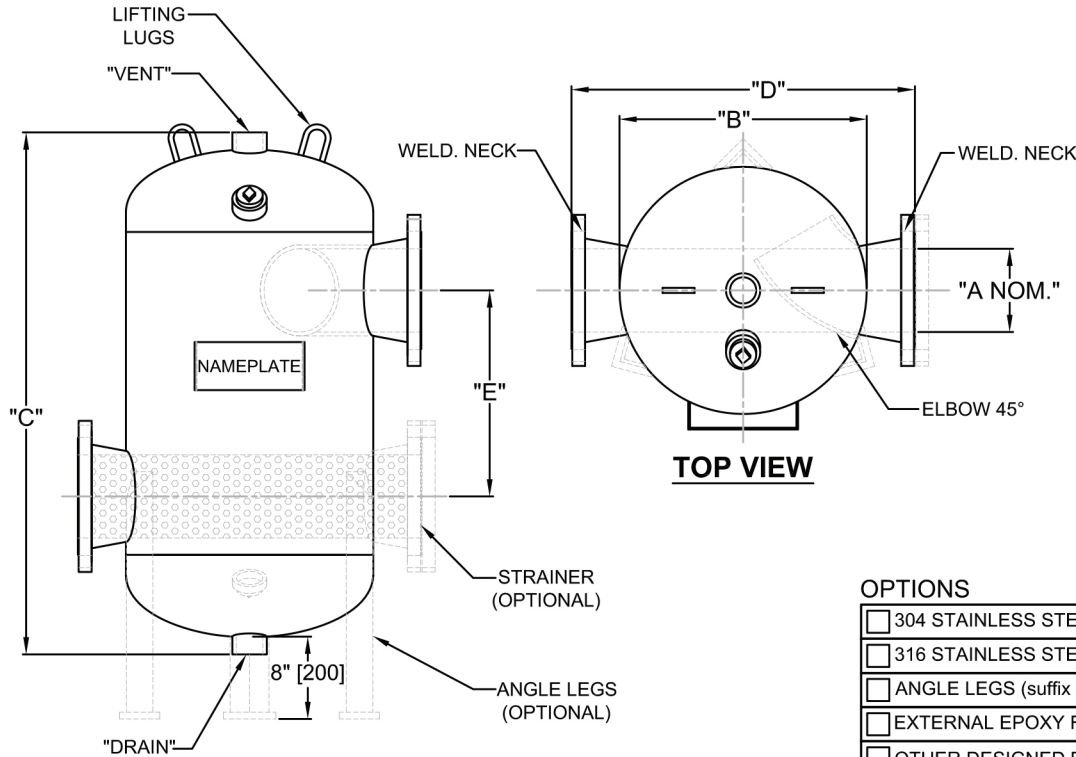

OPTIONS

<input type="checkbox"/>	304 STAINLESS STEEL STRAINER (suffix F4)
<input type="checkbox"/>	316 STAINLESS STEEL STRAINER (suffix F6)
<input type="checkbox"/>	ANGLE LEGS (suffix L)
<input type="checkbox"/>	EXTERNAL EPOXY FINISH (suffix C)
<input type="checkbox"/>	OTHER DESIGNED PRESSURES _____ PSI (_____ kPa) (suffix SPE)

QTY: _____ MODEL: SEP-____-F____ (suffix)

NOTES:

MODEL	DIMENSIONS														INSPECTION HOLES		WEIGHT	
	A NOM.		B		C		D		E		VENT		DRAIN		in	mm	lbs.	kg.
	in	mm	in	mm	in	mm	in	mm	in	mm	in	mm	in	mm				
<input type="checkbox"/> SEP-2.5F(F4)	2-1/2	64	6	152	24	610	10-3/8	264	9	229	3/4	20	3/4	20	3/4	20	72	64
<input type="checkbox"/> SEP-3F(F4)	3	76	8	203	27	686	12-1/8	308	10	254	3/4	20	3/4	20	3/4	20	108	49
<input type="checkbox"/> SEP-4F(F4)	4	102	12	305	29	737	16-3/8	416	12	305	3/4	20	3/4	20	1-1/2	40	110	50
<input type="checkbox"/> SEP-5F(F4)	5	127	16	406	33	838	21	533	13	330	1-1/2	40	1-1/2	40	1-1/2	40	171	78
<input type="checkbox"/> SEP-6F(F4)	6	152	18	457	38	965	22-5/8	575	15	381	1-1/2	40	1-1/2	40	2	50	209	95
<input type="checkbox"/> SEP-8F(F4)	8	203	24	610	48	1219	29-1/4	743	18	457	1-1/2	40	1-1/2	40	2	50	380	173
<input type="checkbox"/> SEP-10F(F4)	10	254	30	762	54	1372	36-1/4	921	20	508	1-1/2	40	1-1/2	40	2	50	638	290
<input type="checkbox"/> SEP-12F(F4)	12	305	36	914	64	1626	44-1/8	1121	24	610	1-1/2	40	1-1/2	40	2	50	902	409
<input type="checkbox"/> SEP-14F(F4)	14	356	42	1067	74	1880	49-3/4	1264	28	711	1-1/2	40	1-1/2	40	MAN HOLE 12" X 16" (300mm X 400mm)		1402	636
<input type="checkbox"/> SEP-16F(F4)	16	406	48	1219	83	2108	55-1/2	1410	32	813	1-1/2	40	1-1/2	40		2016	914	
<input type="checkbox"/> SEP-18F(F4)	18	457	54	1372	92	2337	62	1575	36	914	1-1/2	40	1-1/2	40		2583	1172	
<input type="checkbox"/> SEP-20F(F4)	20	508	60	1524	101	2565	68-1/8	1730	40	1016	1-1/2	40	1-1/2	40		3209	1456	

*DIMENSIONS SUBJECT TO CHANGE WITHOUT NOTICE. DO NOT USE FOR CONSTRUCTION PURPOSES.

NOTE:

BUILT IN ACCORDANCE WITH ASME CODE SECTION VIII 2007-A08
 DIV.1 PARAG. UW-12(C), TEMA , U STAMPED FOR U.S. ONLY.
 OPERATING PRESSURE 150 PSI (1034 kPa)
 HYDROSTATIC TEST AT 195 PSI (1345 kPa)
 DESIGN TEMPERATURE 550°F (288°C)
 MATERIAL SA-516 GR.70
 CARBON STEEL OPENING 3000#
 EXTERNAL PRIMER FINISH
 100% TESTED

 LAKE WORTH FLORIDA, U.S.A. WWW.FLOFAB.COM	TITLE / TITRE VORTEX TYPE AIR SEPARATOR WITH FLANGE CONNECTION - SERIES "SEP"	
	PROJECT / PROJET	TAG
CUSTOMER / CLIENT	DATE	
DRAWING N° / N° DESSIN M. LYMBURNER	DRAWING N° / N° DESSIN AIR SEPARATOR - SEP	LAYOUT
SCALE / ÉCHELLE N/A	REV. 0	



VORTEX TYPE AIR SEPARATOR

(For hydronic heating and cooling systems)

SEP

bul.s.sep0898
replace ---

SPECIFICATIONS

Furnish and install, as shown on plan, a carbon steel vortex air separator with external prime finish.

The Canadian manufactured vortex air separator must be constructed in accordance with the ASME, SECTION VIII, DIV.1 and the CSA B.51.

The vortex air separator must be constructed and registered for a pressure of 150 psi** (1 034 kPa)**, and for a temperature of 550 °F (288 °C), and certified by the local pressure inspector. The manufacturer data report must be furnish with each vortex air separator.

The vortex air separator will have an inlet and outlet diameter of _____ in (_____ mm) and it will be _____ [flange (suffix F) or groove (suffix G)]

Model: SEP- _____ - _____ as manufactured by AQUA PROFAB. or a Canadian equivalent.

OPTIONS

PAINT: The separator must have an external epoxy finish.
(suffix C)

LEGS: The separator will be installed with angle steel legs
(suffix L)

**Other designed pressures are available, consult your local representative.

<<<Call us, we are specialized in custom-made products, it will be a pleasure to manufacture according to your requirements.>>>



AIR & DIRT SEPARATOR

WITH FIXED MEDIUM

MODELS: ADSF-2 TO ADSF-12

UNIT TAG NO.: _____	ORDER NO. _____
ENGINEER: _____	SUBMITTED BY _____ DATE _____
FLO FAB REPRESENTATIVE: _____	APPROVED BY _____ DATE _____

DESCRIPTION

FLO FAB ADSF SERIES AIR & DIRT SEPARATORS ARE DESIGNED TO ELIMINATE ENTRAINED AIR AND SEPARATE DEBRIS ASSOCIATED WITH START-UP AND MAINTENANCE OF ANY HYDRONIC SYSTEM. THE DESIGN INCORPORATES A SKIM VALVE, USED TO ELIMINATE FLOATING DEBRIS, A REMOVABLE END COVER FOR COALESCING MEDIUM ACCESS, AND AN AIR VENT TO AUTOMATICALLY RELEASE AIR FROM THE SEPARATOR. THE DESIGN AND CONSTRUCTION CONFORMS TO ASME SECTION VIII, DIV.1

CONSTRUCTION

SHELL: CARBON STEEL
 COALESCING MEDIUM: STAINLESS STEEL
 BLOW DOWN VALVE (OPTIONAL): BRONZE
 SKIM VALVE (OPTIONAL): BRONZE
 VENT (OPTIONAL): STAINLESS STEEL

PERFORMANCE LIMITATIONS

MAXIMUM DESIGN TEMPERATURE: 250°F
 MAXIMUM DESIGN PRESSURE: 150 PSIG

DIMENSIONS AND WEIGHTS

MODEL	CONN. SIZE	FLOW GPM	D (IN.)	H (IN.)	W (IN.)	A (IN.)	B (IN.)	WT LBS.
ADSF-2-F	2 FLG.	46		23	15-1/4	11-1/2	8-5/8	100
ASDF-2-FNPT	2 NPT.	46		23	10-3/8	11-1/2	8-5/8	90
ADSF-2.5-F	2-1/2 FLG.	72		23	15-3/4	11-1/2	8-5/8	125
ADSF-2.5-FNPT	2-1/2 NPT.	72		23	11	11-1/2	8-5/8	115
ADSF-3-F	3 FLG.	96		29	20-1/4	14-1/2	8-5/8	150
ADSF-3-FNPT	3 NPT.	96		29	12-1/2	14-1/2	8-5/8	130
ADSF-4-F	4 FLG.	170		29	20-5/8	14-1/2	8-5/8	250
ADSF-5-F	5 FLG.	265		39	27-3/4	19-1/2	8-5/8	310
ADSF-6-F	6 FLG.	380		39	27-3/4	19-1/2	8-5/8	375
ADSF-8-F	8 FLG.	630		49	33-5/8	24-1/2	8-5/8	700
ADSF-10-F	10 FLG.	960		65	37-1/2	32-1/2	8-5/8	1000
ADSF-12-F	12 FLG.	1400		76	42-1/2	38	8-5/8	1500

NOTE: LARGER SIZES ARE AVAILABLE UP TO 36 INCHES.

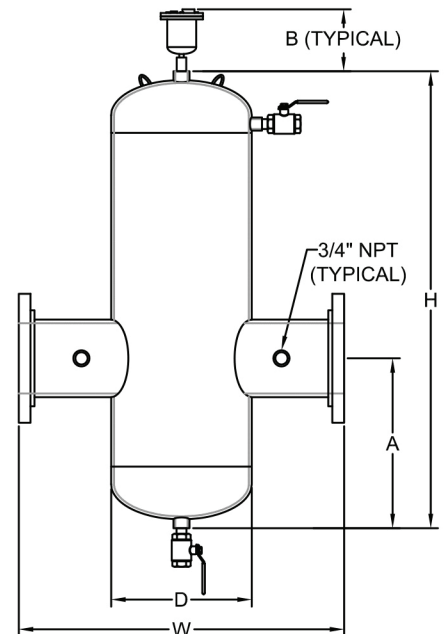

SPECIFICATION

FURNISH AND INSTALL ON THE PLANS AND DESCRIBED HEREIN, A FLO FAB-VENT ADSF AIR & DIRT SEPARATOR AS MANUFACTURED BY FLO FAB COMPANY. EACH SEPARATOR MUST BE DESIGNED WITH A BLOWDOWN VALVE, SKIM VALVE, AND AUTOMATIC AIR VENT. THE SEPARATOR MUST ALSO UTILIZE IN ITS DESIGN A STAINLESS STEEL COALESCING MEDIUM TO AID IN THE SEPARATION OF AIR AND DIRT IN THE SYSTEM ENTRAINED WATER. THE SEPARATOR MUST BE CONSTRUCTED IN ACCORDANCE WITH THE LATEST REVISION OF THE ASME BOILER AND PRESSURE VESSEL CODE AND STAMPED 150 PSI WORKING PRESSURE.

EACH SEPARATOR SHALL BE FLO FAB MODEL ADSF-_____ OR APPROVED EQUAL.



"HIGH VELOCITY" AIR & DIRT SEPARATOR

WITH FIXED MEDIUM

MODELS: ADSF-HV-2 TO ADSF-HV-12

UNIT TAG NO.: _____	ORDER NO. _____
ENGINEER: _____	SUBMITTED BY _____ DATE _____
FLO FAB REPRESENTATIVE: _____	APPROVED BY _____ DATE _____

DESCRIPTION

FLO FAB ADSF-HV (HIGH VELOCITY) SERIES AIR & DIRT SEPARATORS ARE DESIGNED TO ELIMINATE ENTRAINED AIR AND SEPARATE DEBRIS ASSOCIATED WITH START-UP AND MAINTENANCE OF ANY HYDRONIC SYSTEM. THE DESIGN INCORPORATES A SKIM VALVE, USED TO ELIMINATE FLOATING DEBRIS, A REMOVABLE END COVER FOR COALESCING MEDIUM ACCESS, AND AN AIR VENT TO AUTOMATICALLY RELEASE AIR FROM THE SEPARATOR. THE DESIGN AND CONSTRUCTION CONFORMS TO ASME SECTION VIII, DIV.1

CONSTRUCTION

SHELL: CARBON STEEL
 COALESCING MEDIUM: STAINLESS STEEL
 BLOW DOWN VALVE (OPTIONAL): BRONZE
 SKIM VALVE (OPTIONAL): BRONZE
 VENT (OPTIONAL): STAINLESS STEEL

PERFORMANCE LIMITATIONS

MAXIMUM DESIGN TEMPERATURE: 250°F
 MAXIMUM DESIGN PRESSURE: 150 PSIG

DIMENSIONS AND WEIGHTS

MODEL	CONN. SIZE	FLOW GPM	D (IN.)	H (IN.)	W (IN.)	A (IN.)	B (IN.)	WT LBS.
ADSF-HV-2-F	2 FLG.	105	4-1/2	33	15-1/4	11-1/2	8-5/8	110
ADSF-HV-2-FNPT	2 NPT.	105	4-1/2	33	10-3/8	11-1/2	8-5/8	100
ADSF-HV-2.5-F	2-1/2 FLG.	155	5-9/16	33	15-3/4	11-1/2	8-5/8	140
ADSF-HV-2.5-FNPT	2-1/2 NPT.	155	5-9/16	33	11	11-1/2	8-5/8	125
ADSF-HV-3-F	3 FLG.	225	6-5/8	42	20-1/4	14-1/2	8-5/8	175
ADSF-HV-3-FNPT	3 NPT.	225	6-5/8	42	12-1/2	14-1/2	8-5/8	155
ADSF-HV-4-F	4 FLG.	405	8-5/8	42	20-5/8	14-1/2	8-5/8	275
ADSF-HV-5-F	5 FLG.	630	10-3/4	59	27-3/4	19-1/2	8-5/8	475
ADSF-HV-6-F	6 FLG.	910	12-3/4	59	27-3/4	19-1/2	8-5/8	525
ADSF-HV-8-F	8 FLG.	1610	16	75	33-5/8	24-1/2	8-5/8	825
ADSF-HV-10-F	10 FLG.	2450	20	92	37-1/2	32-1/2	8-5/8	1275
ADSF-HV-12-F	12 FLG.	3500	24	110	42-1/2	38	8-5/8	2050

NOTE: LARGER SIZES ARE AVAILABLE UP TO 36 INCHES.

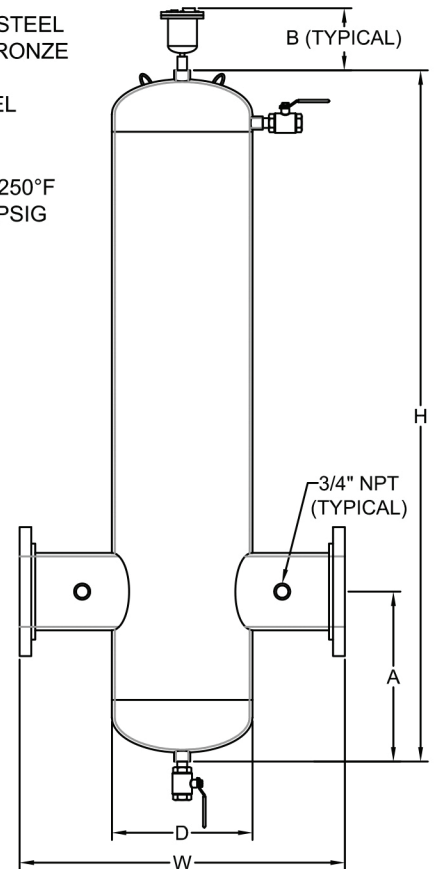

SPECIFICATION

FURNISH AND INSTALL ON THE PLANS AND DESCRIBED HEREIN, A FLO FAB-VENT ADSF-HV (HIGH VELOCITY) AIR & DIRT SEPARATOR AS MANUFACTURED BY FLO FAB COMPANY. EACH SEPARATOR MUST BE DESIGNED WITH A BLOWDOWN VALVE, SKIM VALVE, AND AUTOMATIC AIR VENT. THE SEPARATOR MUST ALSO UTILIZE IN ITS DESIGN A STAINLESS STEEL COALESCING MEDIUM TO AID IN THE SEPARATION OF AIR AND DIRT IN THE SYSTEM ENTRAINED WATER. THE SEPARATOR MUST BE CONSTRUCTED IN ACCORDANCE WITH THE LATEST REVISION OF THE ASME BOILER AND PRESSURE VESSEL CODE AND STAMPED 150 PSI WORKING PRESSURE.

EACH SEPARATOR SHALL BE FLO FAB MODEL ADSF-HV-_____ OR APPROVED EQUAL.



AIR & DIRT SEPARATOR WITH REMOVABLE MEDIUM

MODELS: ADSR-2 TO ADSR-12

UNIT TAG NO.: _____	ORDER NO. _____
ENGINEER: _____	SUBMITTED BY _____ DATE _____
FLO FAB REPRESENTATIVE: _____	APPROVED BY _____ DATE _____

DESCRIPTION

FLO FAB ADSR SERIES AIR & DIRT SEPARATORS ARE DESIGNED TO ELIMINATE ENTRAINED AIR AND SEPARATE DEBRIS ASSOCIATED WITH START-UP AND MAINTENANCE OF ANY HYDRONIC SYSTEM. THE DESIGN INCORPORATES A SKIM VALVE, USED TO ELIMINATE FLOATING DEBRIS, A REMOVABLE END COVER FOR COALESCING MEDIUM ACCESS, AND AN AIR VENT TO AUTOMATICALLY RELEASE AIR FROM THE SEPARATOR. THE DESIGN AND CONSTRUCTION CONFORMS TO ASME SECTION VIII, DIV.1

CONSTRUCTION

SHELL: CARBON STEEL
 COALESCING MEDIUM: STAINLESS STEEL
 BLOW DOWN VALVE (OPTIONAL): BRONZE
 SKIM VALVE (OPTIONAL): BRONZE
 VENT (OPTIONAL): STAINLESS STEEL

PERFORMANCE LIMITATIONS

MAXIMUM DESIGN TEMPERATURE: 250°F
 MAXIMUM DESIGN PRESSURE: 150 PSIG

DIMENSIONS AND WEIGHTS

MODEL	CONN. SIZE	FLOW GPM	D (IN.)	H (IN.)	W (IN.)	A (IN.)	B (IN.)	WT LBS.
ADSR-2-F	2 FLG.	46	9	23	15-1/4	11-1/2	8-5/8	100
ADSR-2-FNPT	2 NPT.	46	9	23	10-3/8	11-1/2	8-5/8	90
ADSR-2.5-F	2-1/2 FLG.	72	10	23	15-3/4	11-1/2	8-5/8	125
ADSR-2.5-FNPT	2-1/2 NPT.	72	10	23	11	11-1/2	8-5/8	115
ADSR-3-F	3 FLG.	96	11	29	20-1/4	14-1/2	8-5/8	150
ADSR-3-FNPT	3 NPT.	96	11	29	12-1/2	14-1/2	8-5/8	130
ADSR-4-F	4 FLG.	170	13-1/2	29	20-5/8	14-1/2	8-5/8	250
ADSR-5-F	5 FLG.	265	16	39	27-3/4	19-1/2	8-5/8	310
ADSR-6-F	6 FLG.	380	19	39	27-3/4	19-1/2	8-5/8	375
ADSR-8-F	8 FLG.	630	23-1/2	49	33-5/8	24-1/2	8-5/8	700
ADSR-10-F	10 FLG.	960	27-1/2	65	37-1/2	32-1/2	8-5/8	1000
ADSR-12-F	12 FLG.	1400	32	76	42-1/2	38	8-5/8	1500

NOTE: LARGER SIZES ARE AVAILABLE UP TO 36 INCHES.

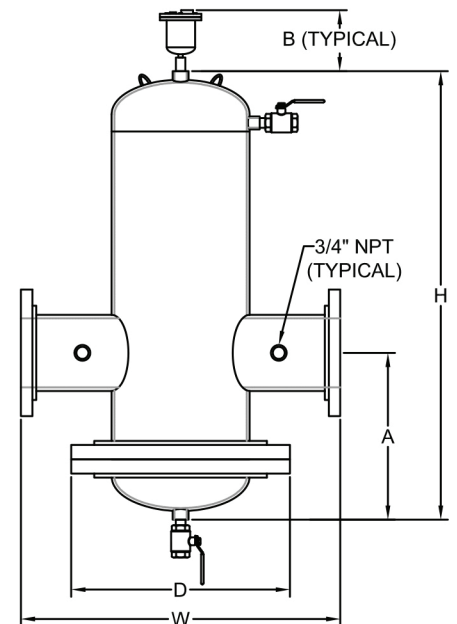

SPECIFICATION

FURNISH AND INSTALL ON THE PLANS AND DESCRIBED HEREIN, A FLO FAB-VENT ADSR AIR & DIRT SEPARATOR AS MANUFACTURED BY FLO FAB COMPANY. EACH SEPARATOR MUST BE DESIGNED WITH A BLOWDOWN VALVE, SKIM VALVE, AND AUTOMATIC AIR VENT. THE SEPARATOR MUST ALSO UTILIZE IN ITS DESIGN A STAINLESS STEEL COALESCING MEDIUM TO AID IN THE SEPARATION OF AIR AND DIRT IN THE SYSTEM ENTRAINED WATER. THE SEPARATOR MUST BE CONSTRUCTED IN ACCORDANCE WITH THE LATEST REVISION OF THE ASME BOILER AND PRESSURE VESSEL CODE AND STAMPED 150 PSI WORKING PRESSURE.

EACH SEPARATOR SHALL BE FLO FAB MODEL ADSR-_____ OR APPROVED EQUAL.



"HIGH VELOCITY" AIR & DIRT SEPARATOR

WITH REMOVABLE MEDIUM

MODELS: ADSR-HV-2 TO ADSR-HV-12

UNIT TAG NO.: _____

ORDER NO. _____

ENGINEER: _____

SUBMITTED BY _____ DATE _____

FLO FAB REPRESENTATIVE: _____

APPROVED BY _____ DATE _____

DESCRIPTION

FLO FAB ADSR-HV (HIGH VELOCITY) SERIES AIR & DIRT SEPARATORS ARE DESIGNED TO ELIMINATE ENTRAINED AIR AND SEPARATE DEBRIS ASSOCIATED WITH START-UP AND MAINTENANCE OF ANY HYDRONIC SYSTEM. THE DESIGN INCORPORATES A SKIM VALVE, USED TO ELIMINATE FLOATING DEBRIS, A REMOVABLE END COVER FOR COALESCING MEDIUM ACCESS, AND AN AIR VENT TO AUTOMATICALLY RELEASE AIR FROM THE SEPARATOR. THE DESIGN AND CONSTRUCTION CONFORMS TO ASME SECTION VIII, DIV.1

CONSTRUCTION

SHELL: CARBON STEEL
 COALESCING MEDIUM: STAINLESS STEEL
 BLOW DOWN VALVE (OPTIONAL): BRONZE
 SKIM VALVE (OPTIONAL): BRONZE
 VENT (OPTIONAL): STAINLESS STEEL

PERFORMANCE LIMITATIONS

MAXIMUM DESIGN TEMPERATURE: 250°F
 MAXIMUM DESIGN PRESSURE: 150 PSIG

DIMENSIONS AND WEIGHTS

MODEL	CONN. SIZE	FLOW GPM	D (IN.)	H (IN.)	W (IN.)	A (IN.)	B (IN.)	WT LBS.
ADSR-HV-2-F	2 FLG.	105	9	33	15-1/4	11-1/2	8-5/8	110
ADSR-HV-2-FNPT	2 NPT.	105	9	33	10-3/8	11-1/2	8-5/8	100
ADSR-HV-2.5-F	2-1/2 FLG.	155	10	33	15-3/4	11-1/2	8-5/8	140
ADSR-HV-2.5-FNPT	2-1/2 NPT.	155	10	33	11	11-1/2	8-5/8	125
ADSR-HV-3-F	3 FLG.	225	11	42	20-1/4	14-1/2	8-5/8	175
ADSR-HV-3-FNPT	3 NPT.	225	11	42	12-1/2	14-1/2	8-5/8	155
ADSR-HV-4-F	4 FLG.	405	13-1/2	42	20-5/8	14-1/2	8-5/8	275
ADSR-HV-5-F	5 FLG.	630	16	59	27-3/4	19-1/2	8-5/8	475
ADSR-HV-6-F	6 FLG.	910	19	59	27-3/4	19-1/2	8-5/8	525
ADSR-HV-8-F	8 FLG.	1610	23-1/2	75	33-5/8	24-1/2	8-5/8	825
ADSR-HV-10-F	10 FLG.	2450	27-1/2	92	37-1/2	32-1/2	8-5/8	1275
ADSR-HV-12-F	12 FLG.	3500	32	110	42-1/2	38	8-5/8	2050

NOTE: LARGER SIZES ARE AVAILABLE UP TO 36 INCHES.

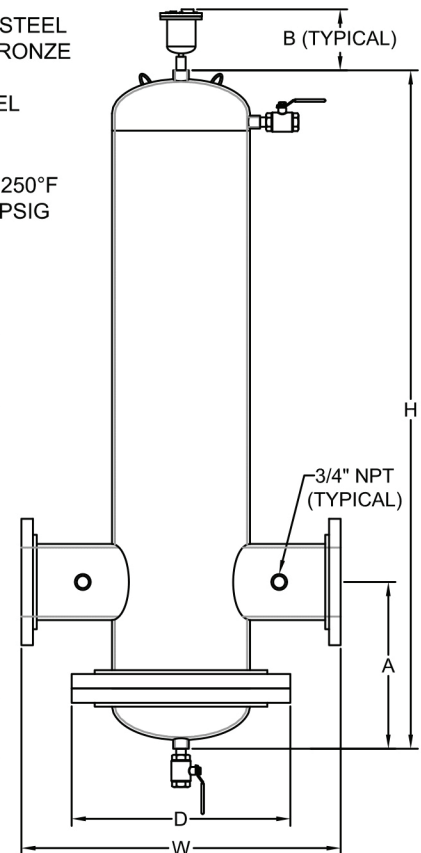



SPECIFICATION

FURNISH AND INSTALL ON THE PLANS AND DESCRIBED HEREIN, A FLO FAB-VENT ADSR-HV (HIGH VELOCITY) AIR & DIRT SEPARATOR AS MANUFACTURED BY FLO FAB COMPANY. EACH SEPARATOR MUST BE DESIGNED WITH A BLOWDOWN VALVE, SKIM VALVE, AND AUTOMATIC AIR VENT. THE SEPARATOR MUST ALSO UTILIZE IN ITS DESIGN A STAINLESS STEEL COALESCING MEDIUM TO AID IN THE SEPARATION OF AIR AND DIRT IN THE SYSTEM ENTRAINED WATER. THE SEPARATOR MUST BE CONSTRUCTED IN ACCORDANCE WITH THE LATEST REVISION OF THE ASME BOILER AND PRESSURE VESSEL CODE AND STAMPED 150 PSI WORKING PRESSURE.

EACH SEPARATOR SHALL BE FLO FAB MODEL ADSR-HV-_____ OR APPROVED EQUAL.

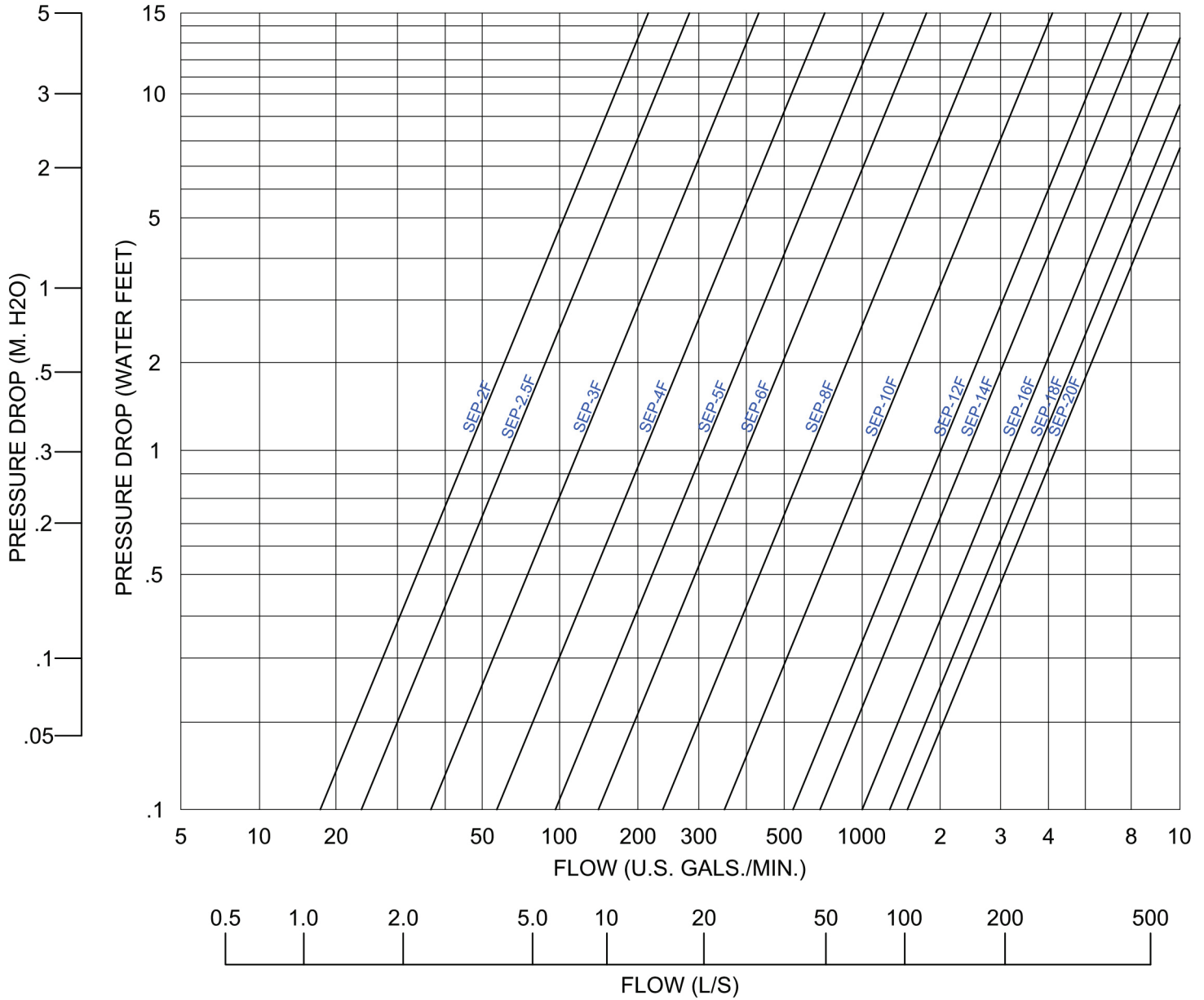
PERFORMANCE CURVE VORTEX AIR SEPARATOR SERIES "SEP"



 LAKE WORTH FLORIDA, U.S.A WWW.FLOFAB.COM	TITLE / TITRE PERFORMANCE CURVE VORTEX AIR SEPARATOR - SERIES "SEP"		
	PROJECT / PROJET	TAG	
	CUSTOMER / CLIENT	DATE	
DRAWN BY / DESSINÉ PAR M. LYMBURNER	DRAWING N° / N° DESSIN AIR SEPARATOR - SEP	LAYOUT	SCALE / ECHELLE N/A
			REV. 0



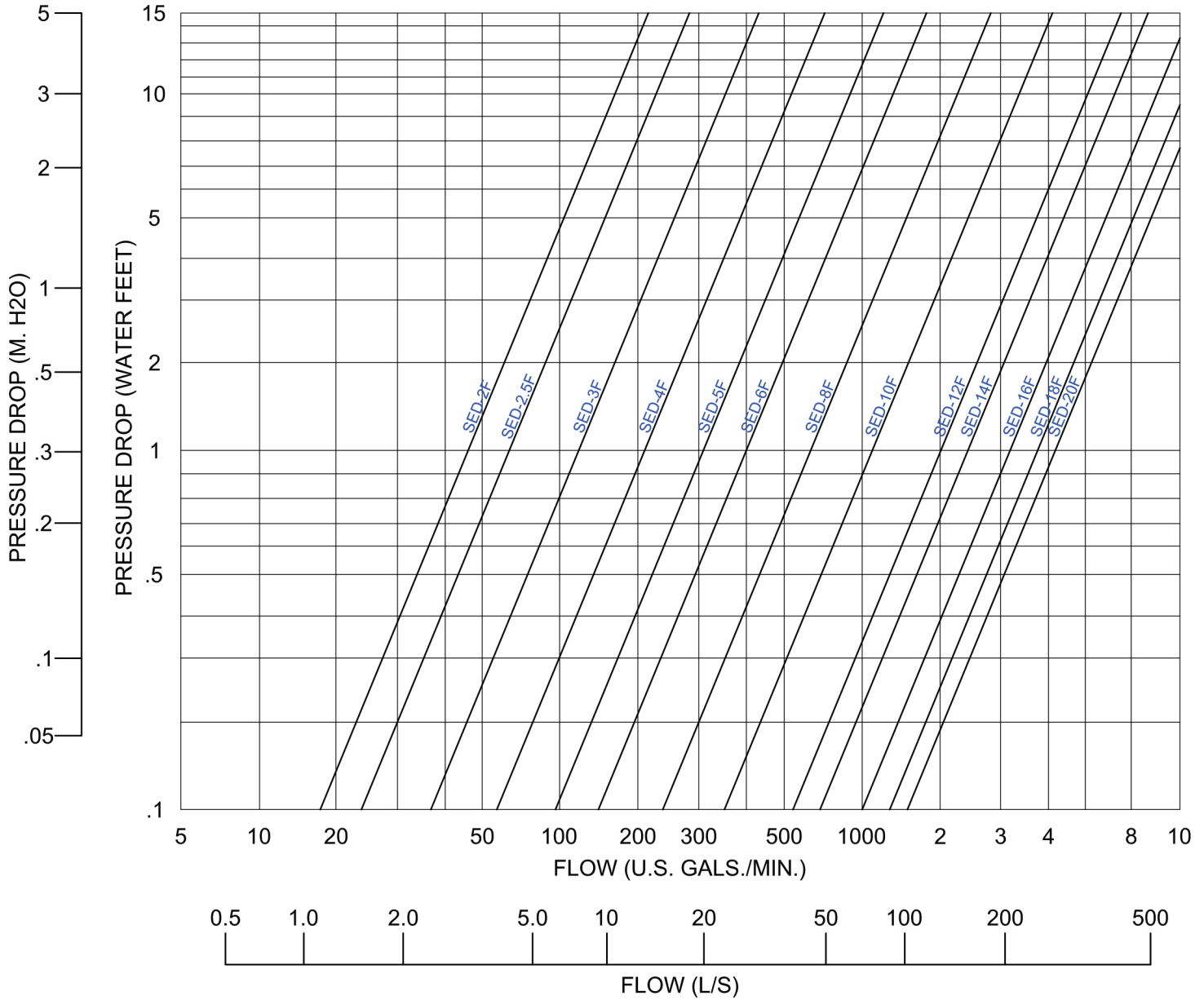

PERFORMANCE CURVE SEDIMENT SEPARATOR SERIES "SED"

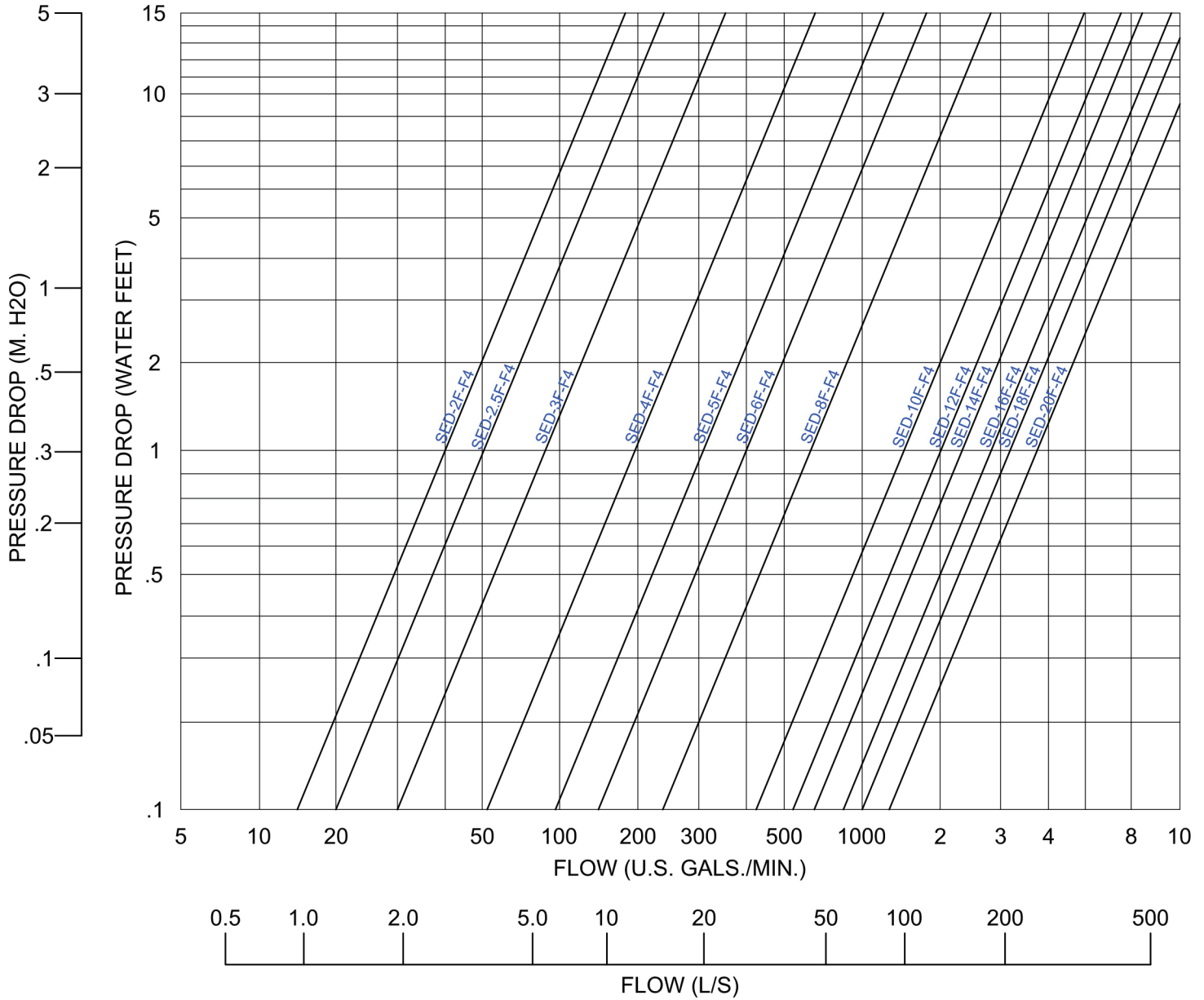

 LAKE WORTH FLORIDA, U.S.A WWW.FLOFAB.COM	TITLE / TITRE PERFORMANCE CURVE SEDIMENT SEPARATOR - SERIES "SED"		
	PROJECT / PROJET		TAG
	CUSTOMER / CLIENT		DATE
DRAWING BY / DESSINÉ PAR M. LYMBURNER	DRAWING N° / N° DESSIN SEDIMENT SEPARATOR - SED	LAYOUT	SCALE / ÉCHELLE N/A
			REV. 0

PERFORMANCE CURVE HIGH VELOCITY SERIES "SED"



 LAKE WORTH FLORIDA, U.S.A WWW.FLOFAB.COM	TITLE / TITRE PERFORMANCE CURVE HIGH VELOCITY - SERIES "SED-F4"		
	PROJECT / PROJET	TAG	
CUSTOMER / CLIENT	DATE		
DRAWING N° / N° DESSIN M. LYMBURNER	DRAWING N° / N° DESSIN SEDIMENT SEPARATOR - SED-F4	LAYOUT	SCALE / ECHELLE N/A
			REV. 0



● Réservoirs ASME Tanks

Série HTS Series

Replaceable bladder expansion tank with bottom system connection
 Réservoir de dilatation à vessie remplaçable avec raccord à la partie inférieure

Série HTL Series Série BT Series

Replaceable bladder expansion tank with top or bottom system connection
 Réservoir de dilatation à vessie remplaçable avec raccord à la partie inférieure ou supérieure

Série BT Series

Replaceable bladder expansion tank with bottom system connection
 Réservoir de dilatation à vessie remplaçable avec raccord à la partie inférieure

Série RDT Series

Fixed bladder expansion tank with top system connection
 Réservoir de dilatation à vessie fixe avec raccord à la partie supérieure

Série RDB Series

Fixed bladder expansion tank with bottom system connection
 Réservoir de dilatation à vessie fixe avec raccord à la partie inférieure

Série PBT Series

Replaceable bladder hydropneumatic expansion with bottom system connection
 Réservoir hydropneumatique à vessie remplaçable avec raccord à la partie inférieure.

Série HDT Series

Fixed bladder expansion tank with top system connection
 Réservoir de dilatation à vessie fixe et avec raccord à la partie supérieure

Série HDB Series

Fixed bladder expansion tank with bottom system connection
 Réservoir de dilatation à vessie fixe et avec raccord à la partie inférieure

Série HB Series

Replaceable bladder expansion tank with bottom system connection
 Réservoir de dilatation à vessie remplaçable avec raccord à la partie inférieure

Série CUS Series

Plain steel expansion tank
 Réservoir de dilatation en acier sans vessie et sans diaphragme

● Réservoir ASME Tanks

Séries HTS-HTL

CARACTÉRIS./FEATURES :

Construit selon les normes ASME, Section VIII, Div., Estampé U

Pression Max. d'opération: 150 PSI (1034 kPa)

Température Max. d'opération: 240°F (115°C)

Constructed in accordance with the ASME, Section VIII, Div., U stamped.

Max. Working Pressure: 150 PSI (1034 kPa)

Max. Working Temperature: 240°F (115°C)

D* = Sur la série HTL la connexion du haut est de même dimension que la connexion D.

D* = On series HTL top connection is same size as D.

Vessie amovible sans couture pour une meilleure durée de vie, élimine la stagnation de l'eau et garde les débris d'eau à l'extérieur. Connexions en acier malléable

Série HTS8-140

Vanne d'air dans un mamelon, sécurisée par une connexion fileté galvanisée de 11/4". Fini externe en apprêt.

Série HTL170-500

Vanne d'air dans un mamelon, sécurisée par une connexion fileté galvanisée de 11/4". Bas de la vessie montée sur bride, dessus avec mamelon. Tamis en dôme au bas fini externe en Top-Pro.

Série HTL600-1000

Connexion avec manomètre et purge de système disponible; la connexion du haut est sécurisée par une connexion fileté galvanisée de 11/4". Disponible avec remplissage par le haut ou par le bas. Tamis en dôme au haut et au bas. Fini externe en Top-Pro.

Removable seamless bladder for longer life operation, eliminating water stagnation, and keeps out water debris. Malleable iron water connections

Series HTS8-140

Air valve inside a protective nipple and secured by 11/4" galvanized threaded plug. External primer finish.

Series HTL170-500

Air valve inside a protective nipple and secured by 11/4" galvanized threaded plug. Bottom bladder flange mount, top with nipple. Top-Pro coated bottom dome strainer.

Series HTL600-1000

Connection with system gauge and system purging available; the top connection is secured by a 11/4" galvanized threaded plug. Available with either top or bottom fill. Top-Pro coated top and bottom domed strainers.

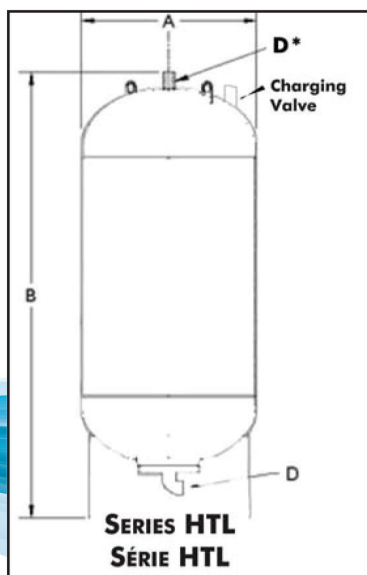

DIMENSIONS :

Modèles Models	Total Volume Volume total		A X B		D (NPT)		Weight Poids	
	gal gal	L L	in X in po X po	mm X mm mm X mm	in po	mm mm	Lbs lb	kg kg
HTS-8	2	8	11 X 10	279 X 254	3/4	19.05	21	9.5
HTS-19	5	19	11 X 19	279 X 483	3/4	19.05	32	14.5
HTS-30	8	30	16 X 15	406 X 381	3/4	19.05	41	18.7
HTS-45	12	45	16 X 23	406 X 584	3/4	19.05	52	23.5
HTS-80	21	80	16 X 37	406 X 940	1	25.4	78	35.5
HTS-100	26.5	100	20 X 41	508 X 1041	1	25.4	83	37.5
HTS-140	37	140	20 X 43	508 X 1092	1	25.4	114	51.5
HTL-170	44	170	20 X 43	508 X 1092	1 1/4	31.75	160	72.5
HTL-200	53	200	20 X 49	508 X 1245	1 1/4	31.75	170	77
HTL-300	80	300	26 X 49	660 X 1245	1 1/4	31.75	215	97.5
HTL-400	105	400	26 X 58	660 X 1473	1 1/4	31.75	248	112.5
HTL-450	120	450	26 X 67	660 X 1702	1 1/4	31.75	283	128.5
HTL-500	132	500	26 X 75	660 X 1905	2	50.8	341	154.5
HTL-600	160	600	26 X 89	660 X 2261	2	50.8	391	177
HTL-800	210	800	30 X 91	762 X 2311	2	50.8	531	240.5
HTL-1000	265	1000	32 X 96	8128 X 2438	2	50.8	561	254.5

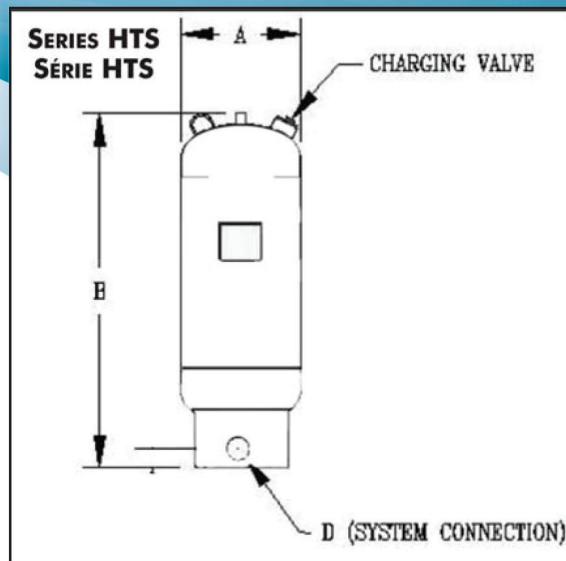



● Réservoir ASME Tanks Séries BT/BT Series

REPLACEABLE BLADDER EXPANSION TANK WITH BOTTOM SYSTEM CONNECTION
RÉSERVOIR DE DILATATION À VESSIE REMPLAÇABLE AVEC RACCORDEMENT À LA PARTIE INFÉRIEURE

- Constructed in accordance with the ASME, Section VIII, Div. 1
- Constructed in accordance with CSA B.51
- Designed pressure of 125 PSI (862 kPa)
- Designed temperature of 240°F (115°C)
- Carbon steel construction
- Butyl replaceable bladder
- Carbon steel bottom system connection (for better efficiency)

- Construction selon les normes ASME, Section VIII, Div. 1
- Construction selon la norme CSA B.51
- Pression de conception 125 lb po. ca. (862 kPa)
- Température maximum de 240°F (115°C)
- Construction d'acier au carbone
- Vessie remplaçable en butyle
- Raccord au système en acier carbone situé dans la partie inférieure (pour un meilleur rendement)

OPTIONS:

- Viseur pour inspection interne
- Support Antiseismique
- Finistion extérieur a l'époxyde
- Berceaux pour reservoir
- Courroie pour soutenir le reservoir aux plafond
- Connection au systeme non centre pour reservoir Hydropneumatique
- Connection 304 en acier inoxydable pour reservoir Hydropneumatique
- Connection 316 en acier inoxydable pour reservoir Hydropneumatique
- Pression de conception 150 lbs
- Pression de conception 200 lbs
- Pression de conception 300 lbs
- Raccord en acier carbon galvanisee



DIMENSIONS :

Models Modèles	Total Volume Volume total		A X B		C		D (NPT)		Weight Poids	
	gal gal	L L	in X in po X po	mm X mm mm X mm	in po	mm mm	in po	mm mm	Lbs lb	kg kg
BT-12V	3	12	12 X 18	305 X 457	2	50	3/4	19	145	66
BT-25V	6.5	25	12 X 24	305 X 610	2	50	3/4	19	160	73
BT-35V	9	35	12 X 30	305 X 762	2	50	3/4	19	170	77
BT-50V	13	50	16 X 27	406 X 686	2	50	3/4	19	205	93
BT-75V	20	75	16 X 34	406 X 864	2	50	3/4	19	225	102
BT-100V	26	100	16 X 42	406 X 1067	2	50	3/4	19	245	111
BT-132V	35	132	16 X 55	406 X 1397	2	50	3/4	19	270	123
BT-160V	42	160	24 X 35	610 X 889	2	50	1	25	305	139
BT-200V	53	200	24 X 40	610 X 1016	2	50	1	25	325	148
BT-250V	66	250	24 X 47	610 X 1194	2	50	1	25	350	159
BT-300V	79	300	24 X 54	610 X 1372	2	50	1	25	380	173
BT-400V	106	400	24 X 67	610 X 1702	2 1/2	64	1 1/4	32	435	198
BT-500V	132	500	24 X 80	610 X 2032	2 1/2	64	1 1/4	32	485	220
BT-600V	159	600	30 X 66	762 X 1676	2 1/2	64	1 1/4	32	535	243
BT-800V	211	800	30 X 84	762 X 2134	2 1/2	64	1 1/4	32	625	284
BT-1000V	264	1000	36 X 77	914 X 1956	3	76	1 1/2	38	803	365
BT-1200V	317	1200	36 X 89	914 X 2261	3	76	1 1/2	38	905	411
BT-1400V	370	1400	36 X 101	914 X 2565	3	76	1 1/2	38	995	452
BT-1600V	423	1600	48 X 76	1220 X 1930	3 1/2	89	2	50	1290	586
BT-2000V	528	2000	48 X 89	1220 X 2261	3 1/2	89	2	50	1465	666
BT-2500V	660	2500	48 X 106	1220 X 2692	3 1/2	89	2	50	1690	768
BT-3000V	793	3000	48 X 123	1220 X 3124	3 1/2	89	2	50	1920	872
BT-4000V	1057	4000	60 X 111	1524 X 2819	4	102	2 1/2	64	2850	1295
BT-5000V	1321	5000	60 X 129	1524 X 3277	4	102	2 1/2	64	3280	1491

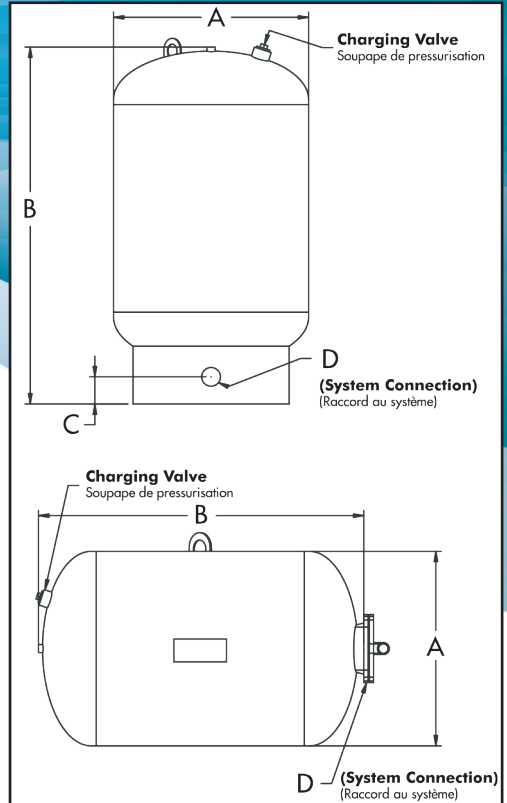



● Réservoir ASME Tanks Séries RDT/RDT Series

FIXED BLADDER EXPANSION TANK WITH TOP SYSTEM CONNECTION
RÉSERVOIR DE DILATATION À VESSIE FIXE AVEC RACCORDEMENT À LA PARTIE SUPÉRIEURE

- Constructed in accordance with the ASME, Section VIII, Div. 1
- Constructed in accordance with CSA B.51
- Designed pressure of 125 PSI (862 kPa)
- Designed temperature of 240°F (115°C)
- Carbon steel construction
- Fixed Butyl bladder
- Carbon steel bottom system connection (for better efficiency)

- Construction selon les normes ASME, Section VIII, Div. 1
- Construction selon la norme CSA B.51
- Pression de conception 125 lb po. ca. (862 kPa)
- Température maximum de 240°F (115°C)
- Construction d'acier au carbone
- Vessie fixe en butyle
- Raccord au système en acier carbone situé dans la partie inférieure (pour un meilleur rendement)



DIMENSIONS :

Models Modèles	Total Volume Volume total		Acceptance Volume Volume Admissible		A X B		C (NPT)		Weight Poids	
	gal gal	L L	gal gal	L L	in X in po X po	mm X mm mm X mm	in po	mm mm	Lbs lb	kg kg
RDT-15V	10	38	4	15	12 X 21	305 X 533	0.5	12.7	61	28
RDT-20V	15	57	4	15	12 X 27	305 X 686	0.5	12.7	73	33
RDT-40V	26	98	11	42	16 X 35	406 X 890	0.5	12.7	120	55
RDT-60V	36	136	11	42	16 X 46	406 X 1169	0.5	12.7	152	69
RDT-80V	48	182	21	79	20 X 40	508 X 1016	0.5	12.7	201	92
RDT-100V	60	227	21	79	20 X 48	508 X 1219	0.5	12.7	221	100
RDT-120V	72	273	34	128	24 X 42	610 X 1067	1	25	267	121
RDT-144V	86	325	34	128	24 X 50	610 X 1270	1	25	288	131
RDT-180V	108	408	48	182	24 X 60	610 X 1524	1	25	326	148
RDT-200V	120	454	48	182	24 X 68	610 X 1727	1	25	404	184
RDT-240V	144	545	55	208	24 X 81	610 X 2057	1	25	433	197
RDT-300V	180	681	55	208	30 X 65	762 X 1651	1	25	455	207
RDT-350V	210	795	66	250	30 X 75	762 X 1905	1	25	520	237

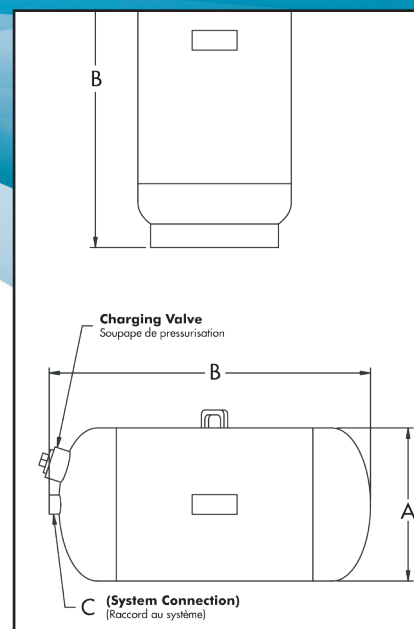



● Réservoir ASME Tanks Séries RDB/RDB Series

REPLACEABLE BLADDER EXPANSION TANK WITH BOTTOM SYSTEM CONNECTION
RÉSERVOIR DE DILATATION À VESSIE REMPLAÇABLE AVEC RACCORDEMENT À LA PARTIE INFÉRIEURE

- Constructed in accordance with the ASME, Section VIII, Div. 1
- Constructed in accordance with CSA B.51
- Designed pressure of 125 PSI (862 kPa)
- Designed temperature of 240°F (115°C)
- Carbon steel construction
- Fixed Butyl bladder
- Carbon steel bottom system connection (for better efficiency)

- Construction selon les normes ASME, Section VIII, Div. 1
- Construction selon la norme CSA B.51
- Pression de conception 125 lb po. ca. (862 kPa)
- Température maximum de 240°F (115°C)
- Construction d'acier au carbone
- Vessie fixe en butyle
- Raccord au système en acier carbone situé dans la partie inférieure (pour un meilleur rendement)



DIMENSIONS :

Models Modèles	Total Volume Volume total		Acceptance Volume Volume Admissible		A X B		C		D (NPT)		Weight Poids	
	gal gal	L L	gal gal	L L	in X in po X po	mm X mm mm X mm	in po	mm mm	in po	mm mm	Lbs lb	kg kg
RDB-15V	10	38	4	15	12 X 24	305 X 609	0.5	12.7	1 1/2	38	71	33
RDB-20V	15	57	4	15	12 X 30	305 X 762	0.5	12.7	1 1/2	38	83	38
RDB-40V	26	98	11	42	18 X 29	457 X 736	0.5	12.7	1 1/2	38	130	60
RDB-60V	36	136	11	42	18 X 40	457 X 1016	0.5	12.7	1 1/2	38	162	74
RDB-80V	48	182	21	79	20 X 43	508 X 1092	0.5	12.7	1 1/2	38	211	97
RDB-100V	60	227	21	79	20 X 51	508 X 1295	0.5	12.7	1 1/2	38	231	105
RDB-120V	72	273	34	128	24 X 46	610 X 1169	1	25	1 3/4	44	282	128
RDB-144V	86	325	34	128	24 X 53	610 X 1347	1	25	1 3/4	44	303	138
RDB-180V	108	408	48	182	24 X 64	610 X 1626	1	25	1 3/4	44	338	154
RDB-200V	120	454	48	182	24 X 72	610 X 1829	1	25	1 3/4	44	419	191
RDB-240V	144	545	55	208	24 X 85	610 X 2159	1	25	1 3/4	44	448	204
RDB-300V	180	681	55	208	30 X 69	762 X 1753	1	25	1 3/4	44	470	214
RDB-350V	210	795	66	250	30 X 79	762 X 2007	1	25	1 3/4	44	535	244

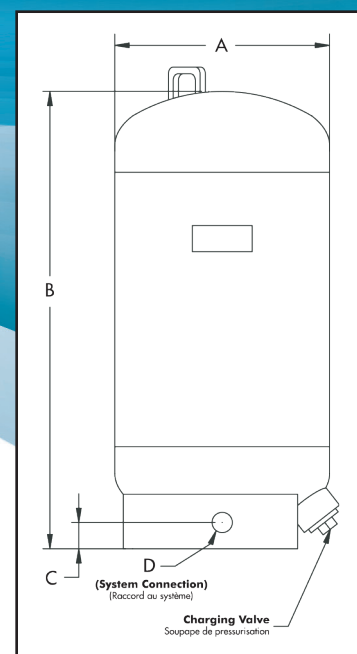



● Réservoir ASME Tanks Séries PBT/PBT Series

REPLACEABLE BLADDER HYDROPNEUMATIC TANK WITH BOTTOM SYSTEM CONNECTION
RÉSERVOIR HYDROPNEUMATIQUE À VESSIE REMPLAÇABLE AVEC RACCORDEMENT À LA PARTIE INFÉRIEURE

- Constructed in accordance with the ASME, Section VIII, Div. 1
- Constructed in accordance with CSA B.51
- Designed pressure of 125 PSI (862 kPa)
- Designed temperature of 240°F (115°C)
- Carbon steel construction
- Butyl replaceable bladder
- Galvanized Carbon steel bottom system connection (for better efficiency)

- Construction selon les normes ASME, Section VIII, Div. 1
- Construction selon la norme CSA B.51
- Pression de conception 125 lb po. ca. (862 kPa)
- Température maximum de 240°F (115°C)
- Construction d'acier au carbone
- Vessie remplaçable en butyle
- Raccord au système en acier carbone galvanisé situé dans la partie inférieure (pour un meilleur rendement)



DIMENSIONS :

Models Modèles	Total Volume Volume total		A X B		C		D (NPT)		Weight Poids	
	gal gal	L L	in X in po X po	mm X mm mm X mm	in po	mm mm	in po	mm mm	Lbs lb	kg kg
PBT-160V	42	160	24 X 38	610 X 965	2	50	1 1/2	25	305	139
PBT-200V	53	200	24 X 43	610 X 1092	2	50	1 1/2	25	325	148
PBT-250V	66	250	24 X 50	610 X 1270	2	50	1 1/2	25	350	159
PBT-300V	79	300	24 X 57	610 X 1448	2	50	1 1/2	25	380	173
PBT-400V	106	400	24 X 70	610 X 1778	2 1/2	64	2	32	435	198
PBT-500V	132	500	24 X 83	610 X 2108	2 1/2	64	2	32	485	220
PBT-600V	159	600	30 X 69	762 X 1753	2 1/2	64	2 1/2	32	535	243
PBT-800V	211	800	30 X 87	762 X 2210	2 1/2	64	2 1/2	32	625	284
PBT-1000V	264	1000	36 X 81	914 X 2057	3	76	3	38	803	365
PBT-1200V	317	1200	36 X 93	914 X 2362	3	76	3	38	905	411
PBT-1400V	370	1400	36 X 104	914 X 2642	3	76	3	38	995	452
PBT-1600V	423	1600	48 X 82	1220 X 2083	6 1/2	165	4	50	1290	586
PBT-2000V	528	2000	48 X 95	1220 X 2413	6 1/2	165	4	50	1465	666
PBT-2500V	660	2500	48 X 112	1220 X 2845	6 1/2	165	4	50	1690	768
PBT-3000V	793	3000	48 X 129	1220 X 3277	6 1/2	165	4	50	1920	872
PBT-4000V	1057	4000	60 X 118	1524 X 2997	7 1/2	191	6	64	2850	1295
PBT-5000V	1321	5000	60 X 139	1524 X 3531	7 1/2	191	6	64	3280	1491

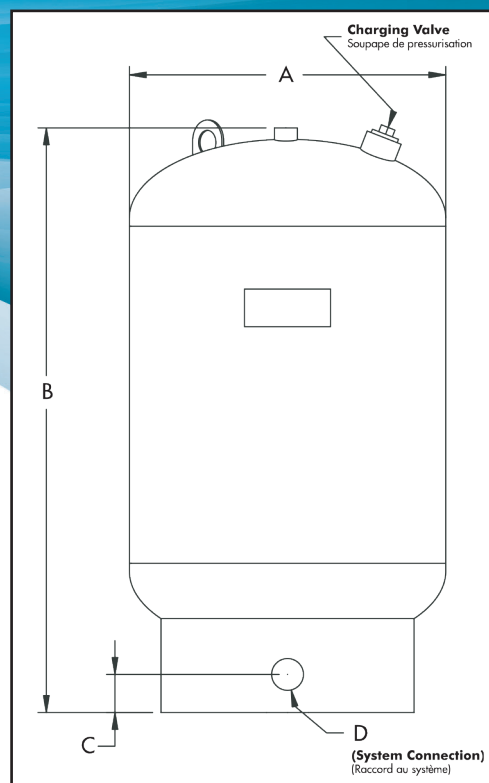

● Réservoir ASME Tanks Séries HDT/HDT Series

FIXED BLADDER EXPANSION TANK WITH TOP SYSTEM CONNECTION
RÉSERVOIR DE DILATATION À VESSIE FIXE AVEC RACCORDEMENT À LA PARTIE SUPÉRIEURE

- Constructed in accordance with the ASME, Section VIII, Div. 1
 - Constructed in accordance with CSA B.51
 - Designed pressure of 125 PSI (862 kPa)
 - Designed temperature of 240°F (115°C)
 - Carbon steel construction
 - Fixed Butyl bladder
 - Stainless Steel bottom system connection (for better efficiency)
-
- Construction selon les normes ASME, Section VIII, Div. 1
 - Construction selon la norme CSA B.51
 - Pression de conception 125 lb po. ca. (862 kPa)
 - Température maximum de 240°F (115°C)
 - Construction d'acier au carbone
 - Vessie fixe en butyle
 - Raccord au système en acier inoxydable situé dans la partie inférieure (pour un meilleur rendement)



DIMENSIONS :

Models Modèles	Total Volume Volume total		Acceptance Volume Volume Admissible		A X B		C (NPT)		Weight Poids	
	gal gal	L L	gal gal	L L	in X in po X po	mm X mm mm X mm	in po	mm mm	Lbs lb	kg kg
HDT-12	5	19	2.7	10	12 X 18	305 X 457	0.75	19	45	20
HDT-20	8.33	32	2.7	10	12 X 20	305 X 508	0.75	19	50	23
HDT-30	12.5	48	8.4	32	16 X 25	406 X 635	1	25	65	30
HDT-42	17.5	66	12	45	16 X 32	406 X 813	1	25	125	57
HDT-60	25	94	12	45	16 X 35	406 X 889	1	25	132	60
HDT-80	33.3	126	15.6	59	20 X 38	508 X 965	1	25	178	81
HDT-105	43.75	166	20	76	20 X 44	508 X 1118	1	25	223	101
HDT-130	54	205	26.4	100	24 X 38	610 X 965	1.25	32	241	110
HDT-155	64.5	244	48.6	184	24 X 46	610 X 1168	1.25	32	385	175
HDT-180	75	284	51	193	24 X 50	610 X 1270	1.25	32	385	175
HDT-210	87.5	331	51	193	24 X 53	610 X 1346	1.25	32	399	182

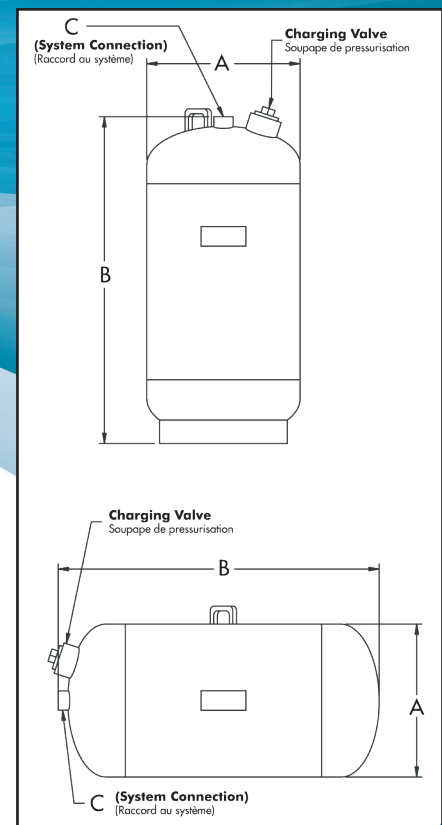

● Réservoir ASME Tanks

Séries HDB/HDB Series

FIXED BLADDER EXPANSION TANK WITH BOTTOM SYSTEM CONNECTION
 RÉSERVOIR DE DILATATION À VESSIE FIXE AVEC RACCORDEMENT À LA PARTIE INFÉRIEURE

- Constructed in accordance with the ASME, Section VIII, Div. 1
 - Constructed in accordance with CSA B.51
 - Designed pressure of 125 PSI (862 kPa)
 - Designed temperature of 240°F (115°C)
 - Carbon steel construction
 - Butyl replaceable bladder
 - Stainless Steel bottom system connection (for better efficiency)
- Construction selon les normes ASME, Section VIII, Div. 1
 - Construction selon la norme CSA B.51
 - Pression de conception 125 lb po. ca. (862 kPa)
 - Température maximum de 240°F (115°C)
 - Construction d'acier au carbone
 - Vessie remplaçable en butyle
 - Raccord au système en acier inoxydable situé dans la partie inférieure (pour un meilleur rendement)



DIMENSIONS :

Models Modèles	Total Volume Volume total		Acceptance Volume Volume Admissible		A X B		C		D (NPT)		Weight Poids	
	gal gal	L L	gal gal	L L	in X in po X po	mm X mm mm X mm	in po	mm mm	in po	mm mm	Lbs lb	kg kg
HDB-12	5	19	2.7	10	12 X 21	305 X 533	3/4	19	1 1/2	38	47	21
HDB-20	8.33	32	2.7	10	12 X 23	305 X 584	3/4	19	1 1/2	38	52	24
HDB-30	12.5	48	8.4	32	16 X 28	406 X 711	1	25	1 3/4	44	67	31
HDB-42	17.5	66	12	45	16 X 35	406 X 889	1	25	1 3/4	44	127	58
HDB-60	25	94	12	45	16 X 38	406 X 965	1	25	1 3/4	44	134	61
HDB-80	33.3	126	15.6	59	20 X 41	508 X 1041	1	25	1 3/4	44	180	82
HDB-105	43.75	166	20	76	20 X 47	508 X 1193	1	25	1 3/4	44	225	102
HDB-130	54	205	26.4	100	24 X 41	610 X 1041	1 1/2	32	2	50	243	111
HDB-155	64.5	244	48.6	184	24 X 68	610 X 1727	1 1/2	32	2	50	387	176
HDB-180	75	284	51	193	24 X 53	610 X 1346	1 1/2	32	2	50	387	176
HDB-210	87.5	331	51	193	24 X 56	610 X 1422	1 1/2	32	2	50	401	183

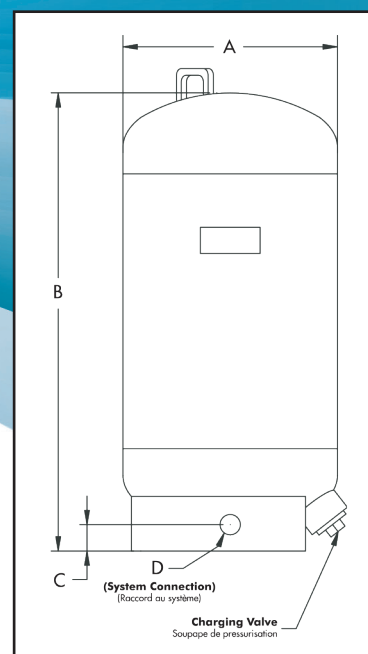

● Réservoir ASME Tanks Séries HB/HB Series

REPLACEABLE BLADDER EXPANSION TANK WITH BOTTOM SYSTEM CONNECTION
RÉSERVOIR DE DILATATION À VESSIE REMPLAÇABLE AVEC RACCORDEMENT À LA PARTIE SUPÉRIEURE

- Constructed in accordance with the ASME, Section VIII, Div. 1
 - Constructed in accordance with CSA B.51
 - Designed pressure of 125 PSI (862 kPa)
 - Designed temperature of 240°F (115°C)
 - Carbon steel construction
 - Butyl replaceable bladder
 - Stainless Steel bottom system connection (for better efficiency)
- Construction selon les normes ASME, Section VIII, Div. 1
 - Construction selon la norme CSA B.51
 - Pression de conception 125 lb po. ca. (862 kPa)
 - Température maximum de 240°F (115°C)
 - Construction d'acier au carbone
 - Vessie remplaçable en butyle
 - Raccord au système en acier inoxydable



DIMENSIONS :

Models Modèles	Total Volume Volume total		A X B		C		D (NPT)		Weight Poids	
	gal gal	L L	in X in po X po	mm X mm mm X mm	in po	mm mm	in po	mm mm	Lbs lb	kg kg
HB-12V	3	12	12 X 21	305 X 533	2	50	3/4	19	145	66
HB-25V	6.5	25	12 X 27	305 X 686	2	50	3/4	19	160	73
HB-35V	9	35	12 X 33	305 X 838	2	50	3/4	19	170	77
HB-50V	13	50	16 X 30	406 X 762	2	50	1	25	205	93
HB-75V	20	75	16 X 37	406 X 940	2	50	1	25	225	102
HB-100V	26	100	16 X 45	406 X 1143	2	50	1	25	245	111
HB-132V	35	132	16 X 58	406 X 1473	2	50	1	25	270	123
HB-160V	42	160	24 X 38	610 X 965	2	50	1 1/2	38	305	139
HB-200V	53	200	24 X 43	610 X 1092	2	50	1 1/2	38	325	148
HB-250V	66	250	24 X 50	610 X 1270	2	50	1 1/2	38	350	159
HB-300V	79	300	24 X 57	610 X 1448	2	50	1 1/2	38	380	173
HB-400V	106	400	24 X 60	610 X 1524	2 1/2	64	2	50	435	198
HB-500V	132	500	24 X 83	610 X 2108	2 1/2	64	2	50	485	220
HB-600V	159	600	30 X 69	762 X 1753	2 1/2	64	2 1/2	64	535	243
HB-800V	211	800	30 X 87	762 X 2210	2 1/2	64	2 1/2	64	625	284
HB-1000V	264	1000	36 X 80	914 X 2032	3	76	3	76	803	365
HB-1200V	317	1200	36 X 92	914 X 2337	3	76	3	76	905	411
HB-1400V	370	1400	36 X 104	914 X 2642	3	76	3	76	995	452
HB-1600V	423	1600	48 X 85	1220 X 2159	6 1/2	165	4	102	1290	586
HB-2000V	528	2000	48 X 95	1220 X 2413	6 1/2	165	4	102	1465	666
HB-2500V	660	2500	48 X 112	1220 X 2845	6 1/2	165	4	102	1690	768
HB-3000V	793	3000	48 X 129	1220 X 3277	6 1/2	165	4	102	1920	872
HB-4000V	1057	4000	60 X 118	1524 X 2997	7 1/2	191	6	150	2850	1295
HB-5000V	1321	5000	60 X 139	1524 X 3531	7 1/2	191	6	150	3280	1491

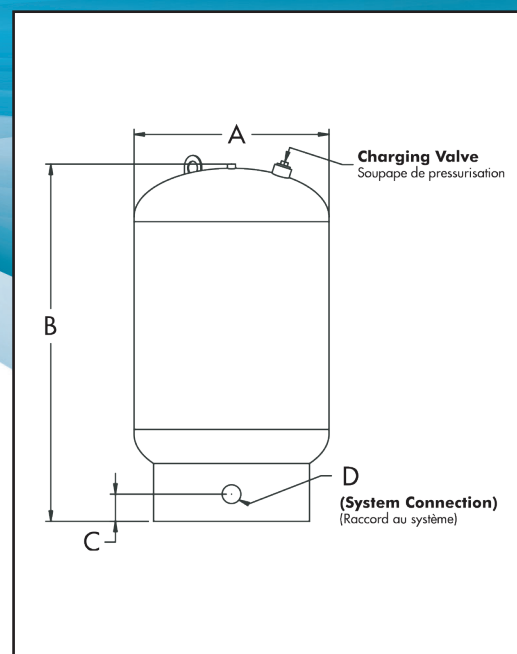

● Réservoir ASME Tanks Séries CUS/CUS Series

PLAIN STEEL EXPANSION TANK RÉSERVOIR DE DILATATION EN ACIER SANS VESSIE ET SANS DIAPHRAGME

- Constructed in accordance with the ASME, Section VIII, Div. 1
 - Constructed in accordance with CSA B.51
 - Designed pressure of 125 PSI (862 kPa)
 - Designed temperature of 240°F (115°C)
 - Carbon steel construction
 - No bladder inside
- Construction selon les normes ASME, Section VIII, Div. 1
 - Construction selon la norme CSA B.51
 - Pression de conception 125 lb po. ca. (862 kPa)
 - Température maximum de 240°F (115°C)
 - Construction d'acier au carbone
 - Aucune vessie à l'intérieur



DIMENSIONS :

Models Modèles	Total Volume Volume total		A X B		C		D		E (NPT)		F (NPT)		Weight Poids	
	gal gal	L L	in X in po X po	mm X mm mm X mm	in po	mm mm	in po	mm mm	in po	mm mm	in po	mm mm	Lbs lb	kg kg
CUS-1234	16	62	12 X 34	305 X 864	10	254	7	178	1	25	1/2	12.7	75	34
CUS-1250	24	91	12 X 50	305 X 1270	10	254	7	178	1	25	1/2	12.7	110	50
CUS-1636	30	114	16 X 36	406 X 914	12	305	8	203	1	25	1/2	12.7	105	47
CUS-1647	40	151	16 X 47	406 X 1194	12	305	8	203	1	25	1/2	12.7	137	62
CUS-1670	60	227	16 X 70	406 X 1778	12	305	8	203	1	25	1/2	12.7	205	93
CUS-2061	80	303	20 X 61	508 X 1549	18	457	10	254	1	25	1/2	12.7	230	105
CUS-2076	100	379	20 X 76	508 X 1930	18	457	10	254	1	25	1/2	12.7	284	129
CUS-2464	120	454	24 X 64	610 X 1626	20	508	10 1/2	267	1	25	1/2	12.7	297	135
CUS-2472	135	511	24 X 72	610 X 1829	20	508	10 1/2	267	1	25	1/2	12.7	333	151
CUS-3062	175	662	30 X 62	762 X 1575	24	610	12	305	1 1/2	38	1/2	12.7	353	161
CUS-3076	220	833	30 X 76	762 X 1930	24	610	12	305	1 1/2	38	1/2	12.7	471	214
CUS-3083	240	909	30 X 83	762 X 2108	24	610	12	305	1 1/2	38	1/2	12.7	506	230
CUS-30104	305	1155	30 X 104	762 X 2642	24	610	12	305	1 1/2	38	1/2	12.7	623	283
CUS-3692	385	1457	36 X 92	914 X 2337	30	762	16	406	1 1/2	38	1/2	12.7	894	406
CUS-3696	400	1514	36 X 96	914 X 2438	30	762	16	406	1 1/2	38	1/2	12.7	923	420
CUS-4872	505	1912	48 X 72	1220 X 1829	42	1067	20	508	1 1/2	38	1/2	12.7	1512	687
CUS-4874	525	1987	48 X 74	1220 X 1880	42	1067	20	508	2	50	1/2	12.7	1552	705
CUS-6070	750	2839	60 X 70	1524 X 1778	54	1372	22	560	2	50	1/2	12.7	1975	898
CUS-6091	1000	3785	60 X 91	1524 X 2311	54	1372	22	560	2	50	1/2	12.7	2426	1103
CUS-60131	1500	5678	60 X 131	1524 X 3327	54	1372	22	560	2	50	1/2	12.7	3326	1512
CUS-60172	2000	7570	60 X 172	1524 X 4369	54	1372	22	560	2	50	1/2	12.7	4225	1921

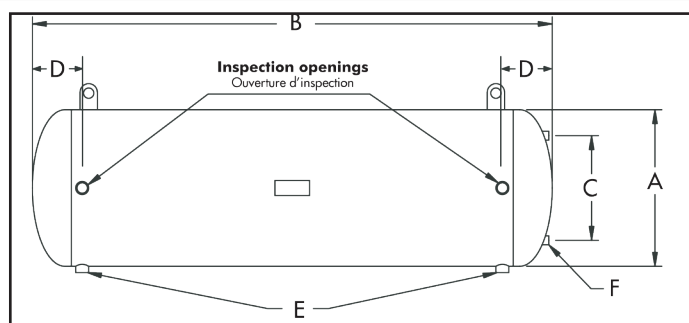



● Détails d'installation Installation Details

SIMPLE INSTALLATION

INSTALLATION SIMPLE

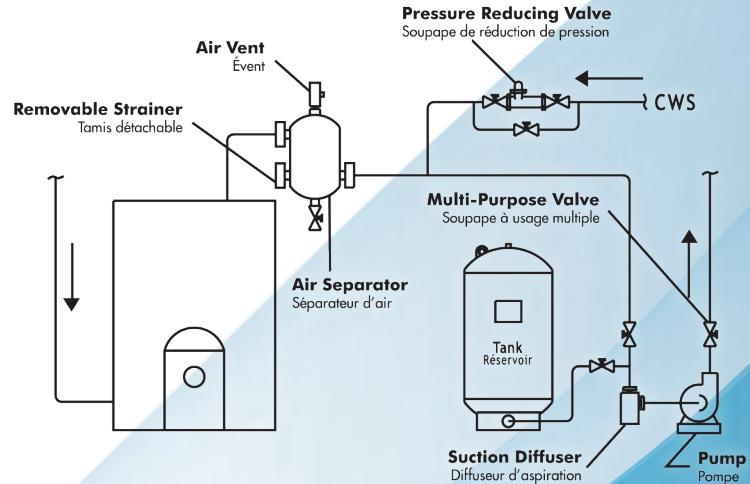

HORIZONTAL INSTALLATION

(OPTIONAL)

INSTALLATION HORIZONTALE

(OPTIONNELLE)

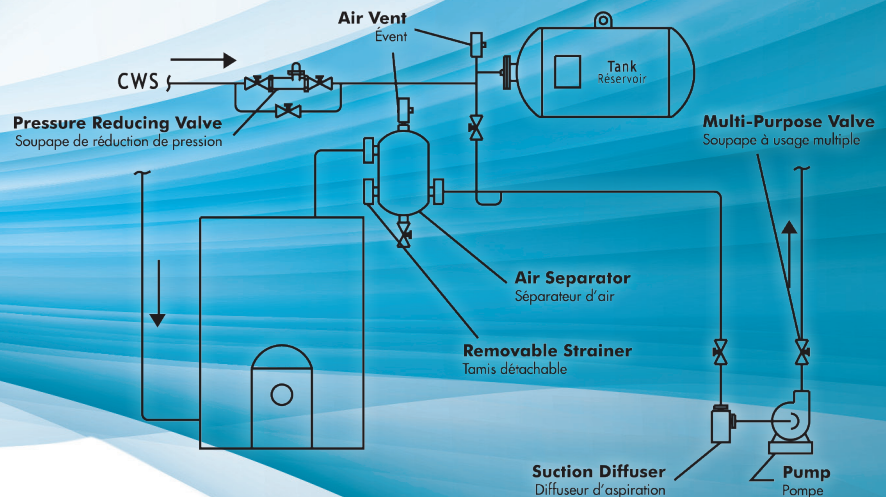

MULTI INSTALLATION

INSTALLATION MULTIPLE

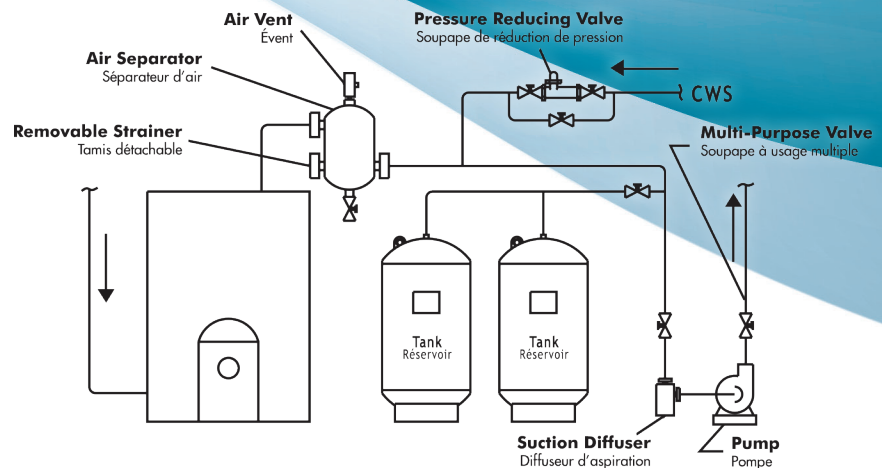

Nous sommes fier fournisseur des projets suivants, soient terminés ou en cours de projets :



Las Positas College
3000 Campus Hill Dr,
Livermore, CA, USA
94551



The West Mall
25 The West Mall,
Toronto, ON
M9C 1B8



Baliscus
1075 Grand Héron Boul.,
Saint-Jérôme, QC, CA
J5L 1G2

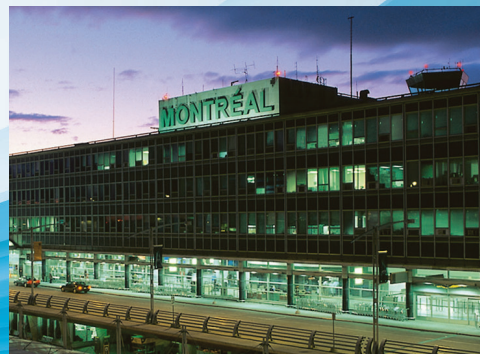

**Montréal – P.E.T
International Airport,**
975 boul. Roméo-Vachon
Dorval, Quebec, H4Y 1H1

Ventes & Service:

Québec, Canada
Tel. : (450) 621-2995
Fax : (450) 621-4995

Lake Worth
Florida, USA
33467-5749

Toronto, Canada
Tel. : +1 (647) 544-2995

www.flofab.com

SERVICE 24/7 : parts@flofab.com

