



# MODEL # RWUH-36-126

## Design Notes

Code..... ASME Sec IV HLW  
 Design Pressure..... 125 psi  
 Test Pressure..... 125 psi  
 Interior..... Glass Lining  
 Exterior..... Baked Enamel Steel Jacket  
 Insulation..... 2" R-12 Open cell foam  
 Supports..... Saddles  
 Capacity..... 515 Gal. / 555 nominal  
 Weight..... 1260 Lbs.

## Material Specifications

Heads..... Carbon Steel  
 Shell..... Carbon Steel  
 Jacket..... 24 Gauge Steel  
 Couplings..... Carbon Steel  
 Flanges..... N/A  
 Pipe..... N/A  
 Manway..... N/A

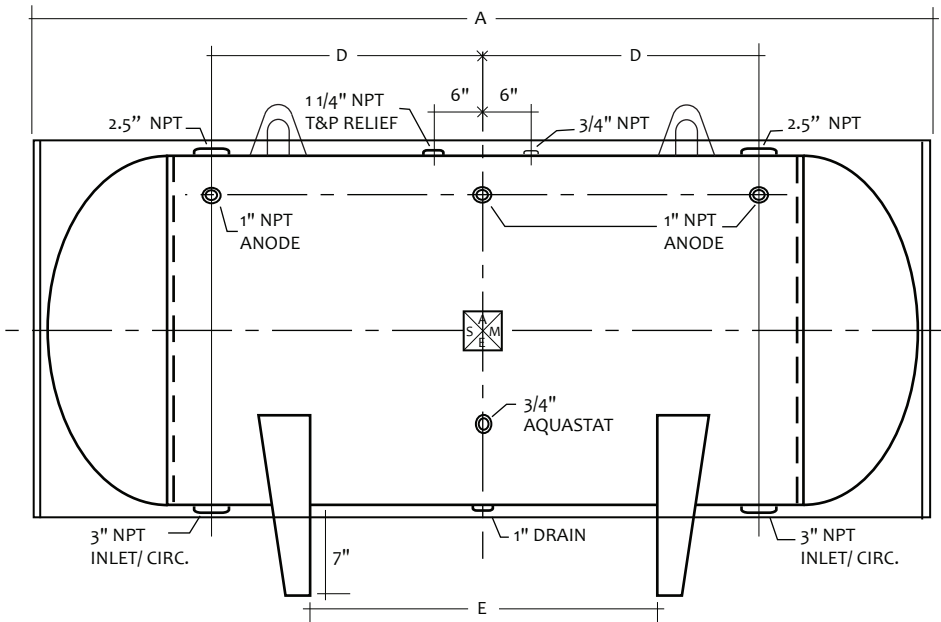

HORIZONTAL STORAGE TANK

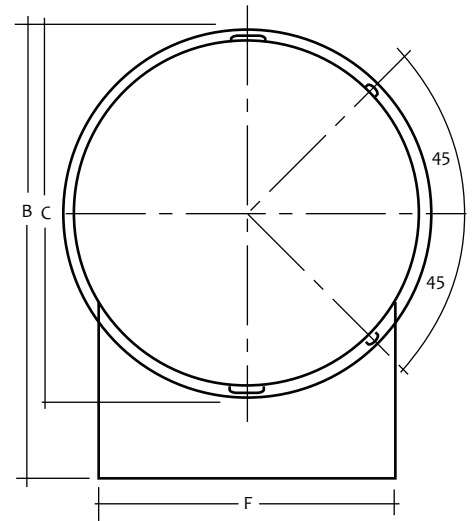

Mark	Dimension	Remark	NOTES
A	130"	Overall length	PROJECT
B	47"	Overall height	CUSTOMER
C	40"	Diameter	SCALE Not to Scale
D	48"	Circulation	DATE
E	72"	Supports	CUSTOMER P.O. #
F	31.69"	Support width	DRAWING Rev NO.