



# MODEL # RWUH-42-105

## Design Notes

Code..... ASME Sec IV HLW  
 Design Pressure..... 125 psi  
 Test Pressure..... 125 psi  
 Interior..... Glass Lining  
 Exterior..... Baked Enamel Steel Jacket  
 Insulation..... 2" R-12 Open cell foam  
 Supports..... Saddles  
 Capacity..... 575 Gal. / 630 nominal  
 Weight..... 1263 Lbs.

## Material Specifications

Heads..... Carbon Steel  
 Shell..... Carbon Steel  
 Jacket..... 24 Gauge Steel  
 Couplings..... Carbon Steel  
 Flanges..... N/A  
 Pipe..... N/A  
 Manway..... Carbon Steel

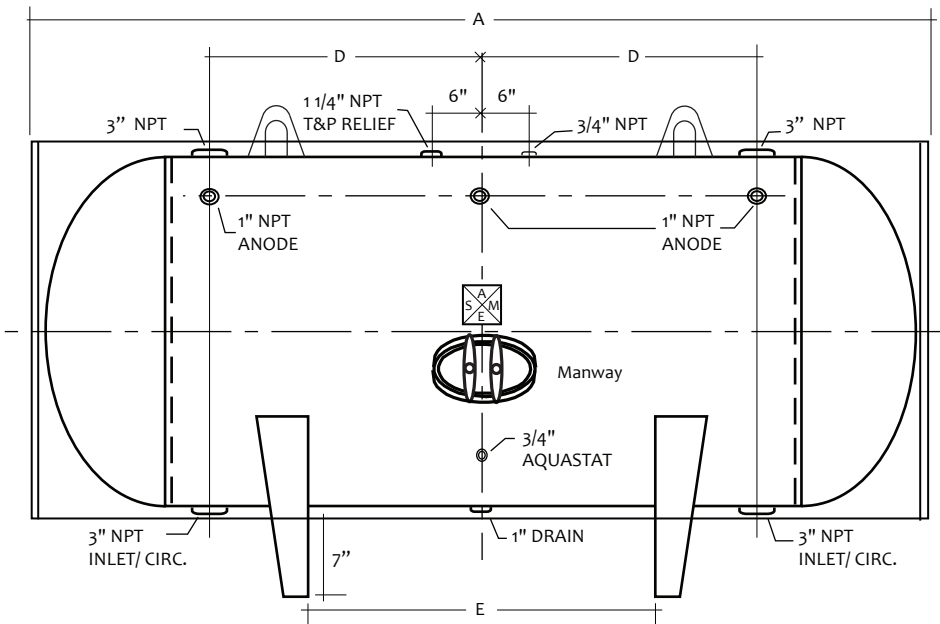

HORIZONTAL STORAGE TANK

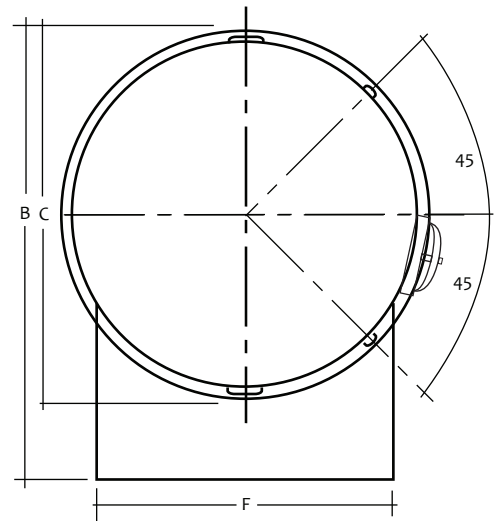

Mark	Dimension	Remark	NOTES
A	109"	Overall length	PROJECT
B	53"	Overall height	CUSTOMER
C	46"	Diameter	SCALE Not to Scale
D	36"	Circulation	DATE
E	48"	Supports	CUSTOMER P.O. #
F	36.75"	Support width	DRAWING Rev NO.